

Solenoid Changeover Kits

3A1162B

ENG

Increases shot accuracy and eliminates changeovers on shots that are less than 20% of the pump volume when added to SmartWare™ Shot Dispense Kits.
For professional use only.

Not for use in explosive atmospheres.

Part 262453

Changeover kit for NXT®2200 and larger air motors.

Part 262464

Changeover kit for NXT1800 and smaller air motors.



Important Safety Instructions

Read all warnings and instructions in this manual and the SmartWare Shot Dispense Kit manual. Save all instructions.

Install Changeover Kit 262453

1. Assemble the air fittings onto the solenoid valve as shown in the following figure.

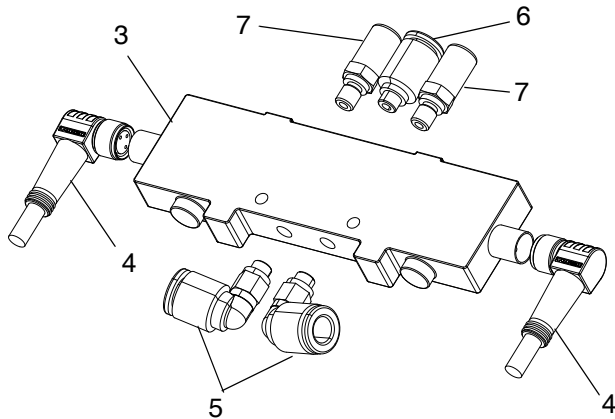

FIG. 1: Assemble Fittings

2. Stop the pump at the middle of its stroke.
3. Relieve pressure. See the SmartWare Shot Dispense Kit Instructions-Parts manual for pressure relief instructions.

<p>Trapped air can cause the pump to cycle unexpectedly, which could result in serious injury from splashing or moving parts</p>						

4. Disconnect the air line to the air motor.
5. Remove the air motor top cover using a flat head screwdriver.

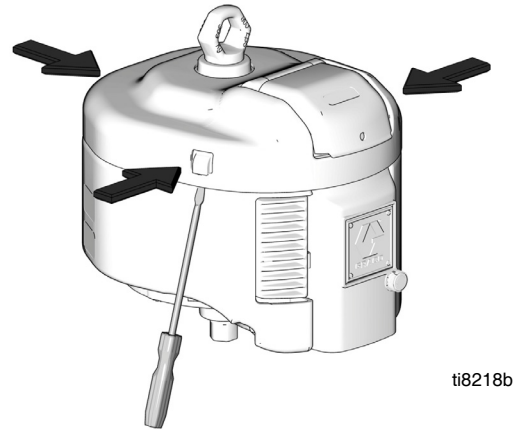

FIG. 2: Remove Air Motor Cover

6. Remove the screw on the outer valve cover to remove the cover.
7. Remove the ten screws from the valve cover to remove the cover, spring-loaded detent, and gasket.
8. Remove both end cap retainer pins from their holes.

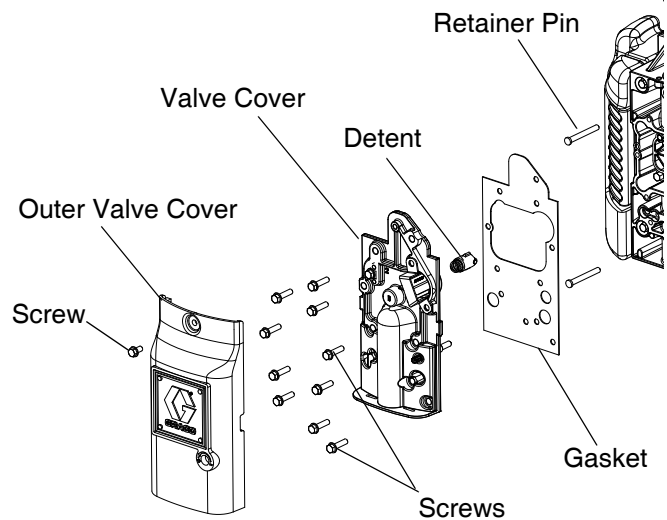

FIG. 3: Disassemble Front of Air Motor

- Invert the retainer pins and slide the heads into the slots on the existing piston valve stops. Use the retainer pins to pull the piston valve stops out.

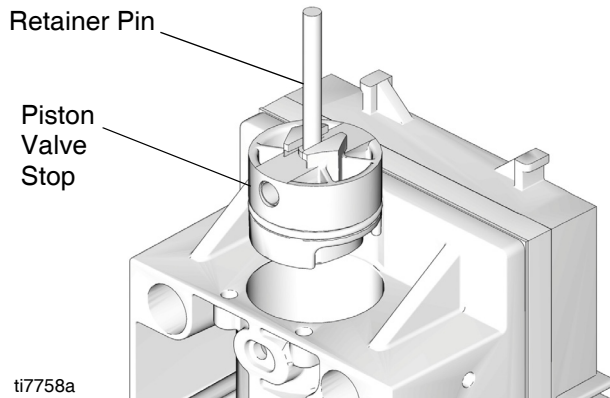

FIG. 4: Remove Existing Piston Valve Stops

- Install a new piston valve stop (1), o-ring (14), and elbow fitting (20) in the top of the valve body. Apply a liberal amount of lubricant (17) to the o-ring before installation.

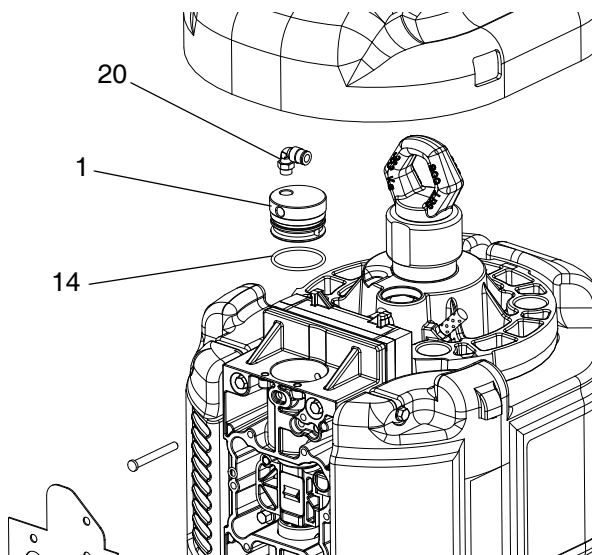

FIG. 5: Install Top Piston Valve Stop

- Install a new piston valve stop (1), o-ring (14), and straight fitting (15) in the bottom of the valve body. Apply a liberal amount of lubricant (17) to the o-ring before installation.

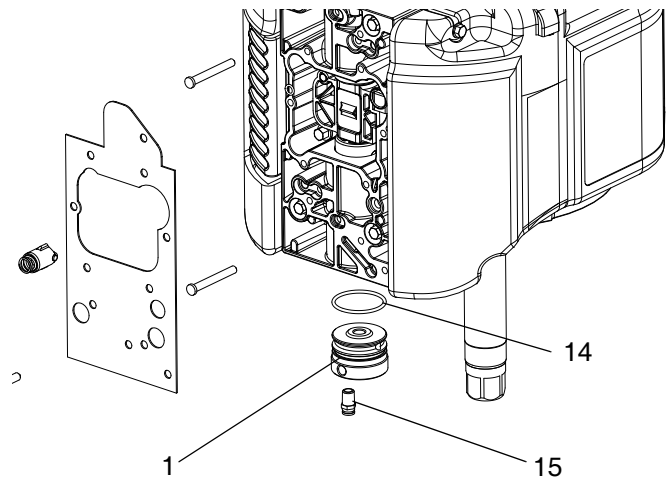

FIG. 6: Install Bottom Piston Valve Stop

12. Install the solenoid bracket (2) to the top of the valve body using the two mounting screws (10) and washers (11).
13. Install the solenoid valve assembly (3) to the solenoid bracket using the two solenoid valve screws (12).

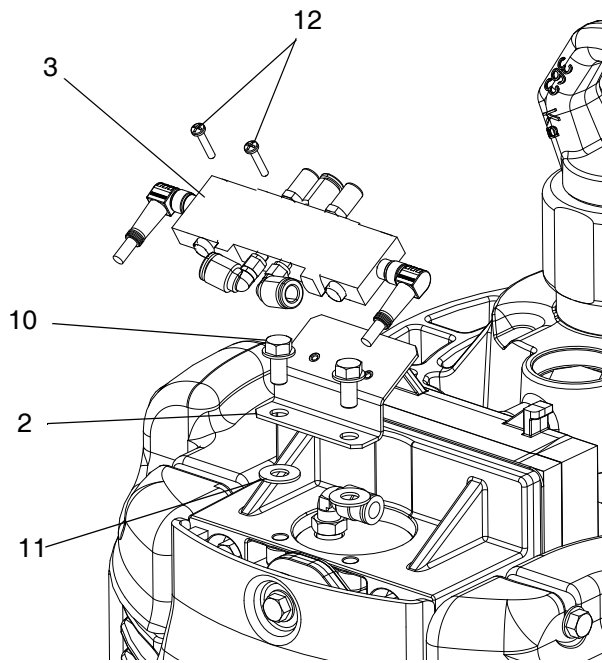

Fig. 7: Install Solenoid Valve Assembly

14. Connect cables and air lines as shown in FIG. 8. Cut air line tubes to length.

NOTE: To avoid kinks in air lines when connecting them from the solenoid valve to the piston valve stop, use large radius bends in the air lines and support tubing with the supplied cable ties.

NOTE: For supply systems, ensure there is enough cable and air line tubing to allow for full ram extension.

15. Reassemble air motor. Follow steps 6 through 3 in reverse order.
16. Tee into your existing air supply, upstream from any regulators, to provide air to the solenoid air supply. Ensure there is a minimum of 70 psi (0.49 MPa, 4.9 bar).

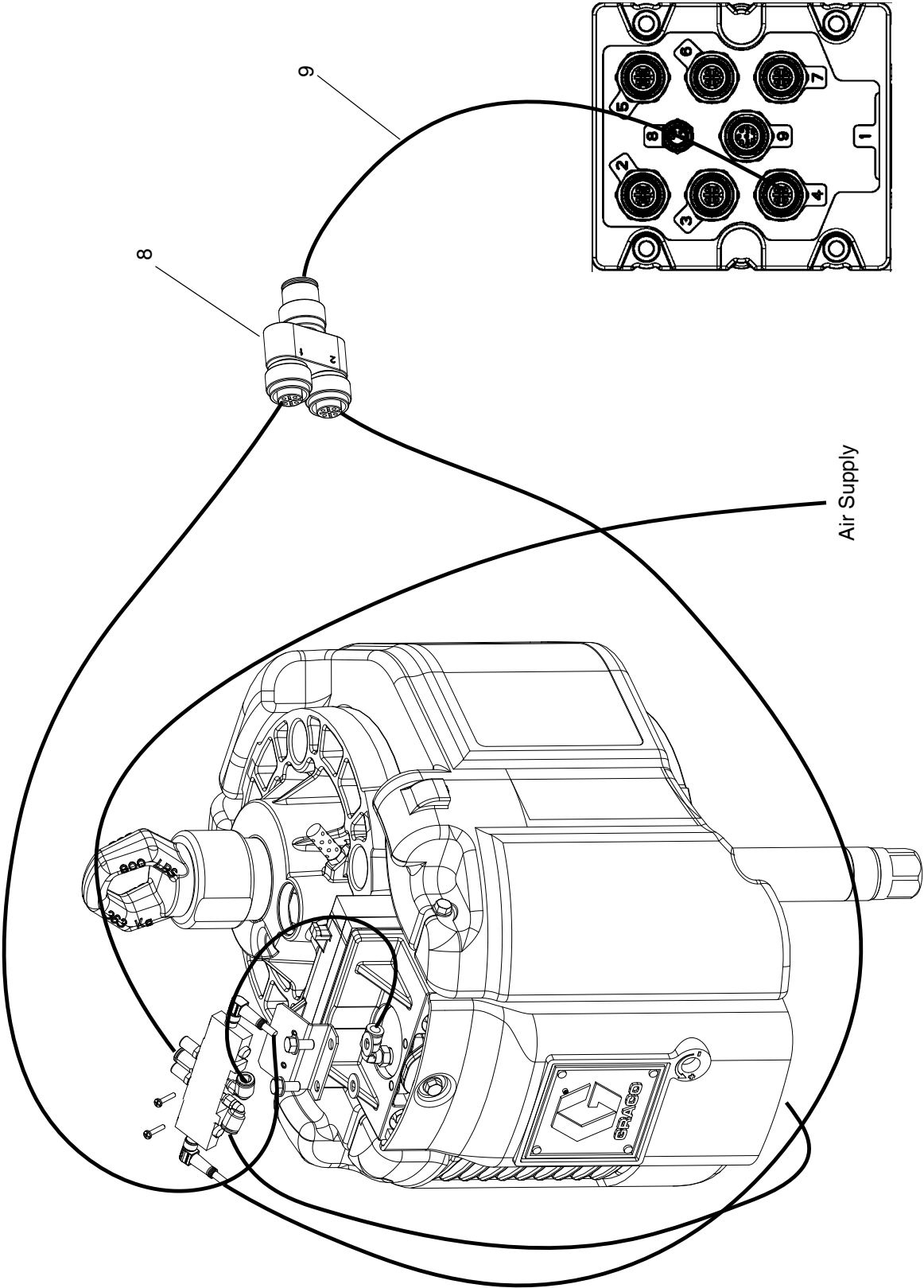

FIG. 8: Connect Cables and Air Lines - NXT2200 and Larger Air Motors

Install Changeover Kit 262464

1. Assemble the air fittings onto the solenoid valve as shown in the following figures.

NOTE: Use the following table to determine which figure corresponds to the air motor used by your system.

Air Fitting Figures According to System and Air Motor					
	M02xxx	M04xxx	M07xxx	M12xxx	M18xxx
D200 Rams	FIG. 9	FIG. 9	FIG. 9	FIG. 9	FIG. 9
S20 Rams	FIG. 10	FIG. 10	FIG. 10	FIG. 9	FIG. 9

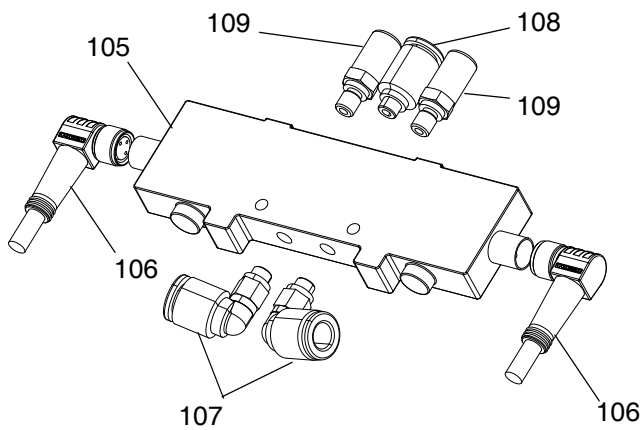

FIG. 9: Assemble Fittings

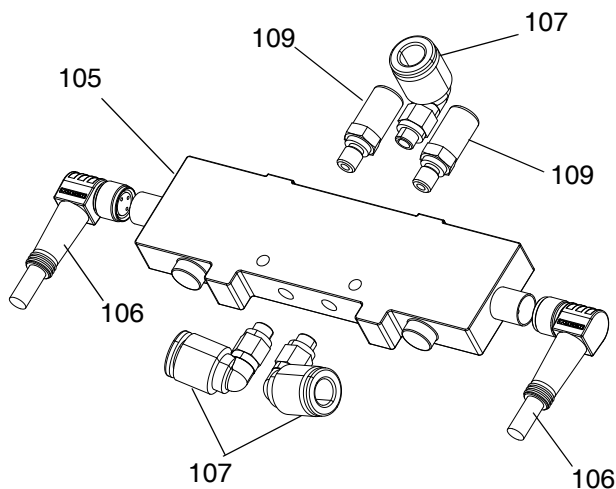

FIG. 10: Assemble Fittings

2. Stop the pump at the middle of its stroke.
3. Relieve pressure. See the SmartWare Shot Dispense Kit Instructions-Parts manual for pressure relief instructions.

Trapped air can cause the pump to cycle unexpectedly, which could result in serious injury from splashing or moving parts						

4. Disconnect the air line to the air motor.
5. Remove the existing snap ring from each end of the air valve.
6. Use the piston to push the existing air valve plug out of each end.
7. Remove the existing o-rings from each end.

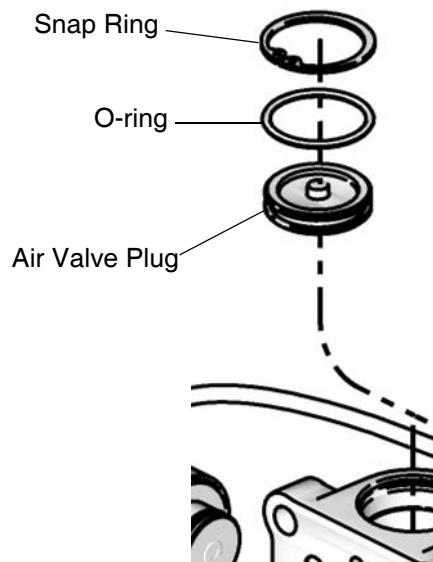

FIG. 11: Remove Existing Air Valve Plug

- Install the top o-ring (116 or 117), air valve plug (101 or 102), snap ring (118 or 119), and elbow fitting (107) in the top of the valve body. Apply a liberal amount of the supplied lubricant to the o-rings before installation. Refer to FIG. 12 and FIG. 13.

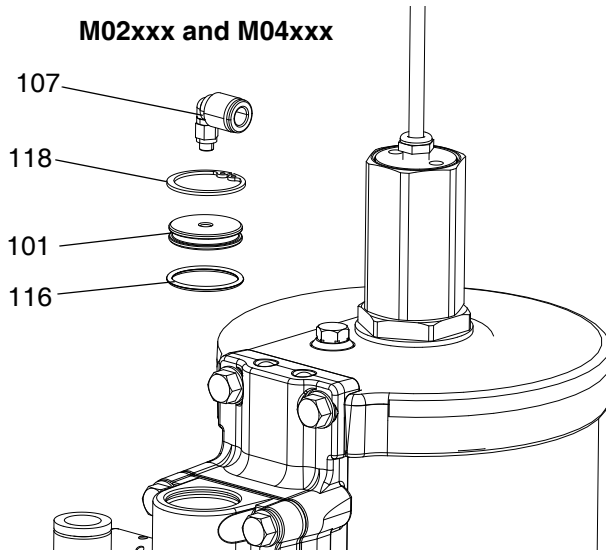

FIG. 12: Install Top Air Valve Plug

- Install the bottom o-ring (116 or 117), air valve plug (101 and 102), snap ring (118 and 119), and elbow fitting (107) in the bottom of the valve body. Apply a liberal amount of the supplied lubricant to the o-rings before installation. Refer to FIG. 14 and FIG. 15.

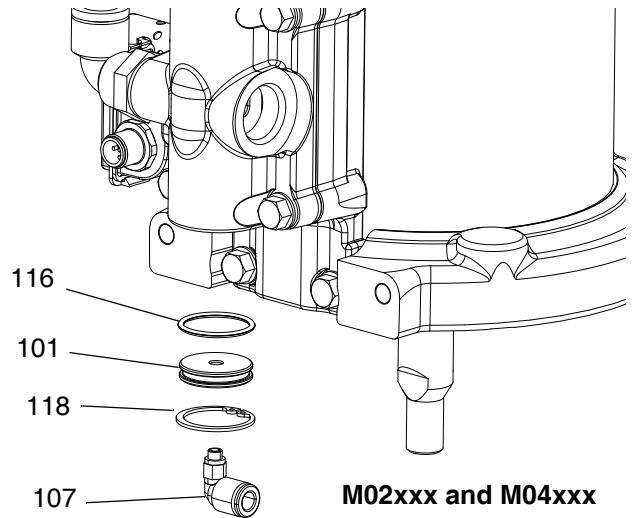

FIG. 14: Install Bottom Air Valve Plug

M07xxx, M12xxx, and M18xxx

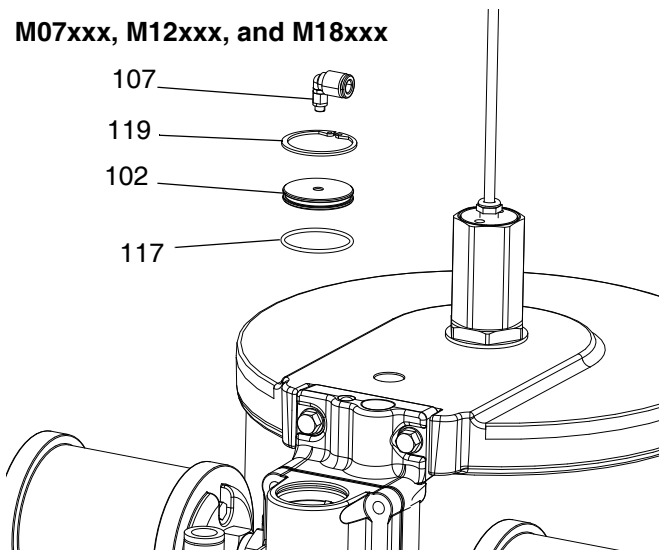

FIG. 13: Install Top Air Valve Plug

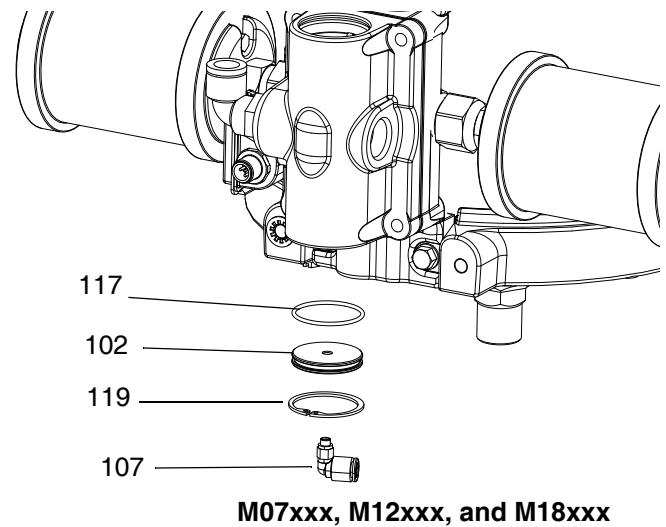

FIG. 15: Install Bottom Air Valve Plug

10. Mount the solenoid valve assembly (105) onto the correct bracket (103 or 104) for your air motor using the screws (114) and washers (115) as shown in FIG. 16 and FIG. 17.
11. Install the solenoid bracket (103 or 104) to the back of the air motor body using the two mounting screws (112) and washers (113) as shown in FIG. 16 and FIG. 17.

NOTE: Use the following table to determine which figure corresponds to the air motor used by your system.

Solenoid Bracket Figures According to System and Air Motor					
	M02xxx	M04xxx	M07xxx	M12xxx	M18xxx
D200 Rams	FIG. 16	FIG. 16	FIG. 16	FIG. 16	FIG. 16
S20 Rams	FIG. 16	FIG. 16	FIG. 16	FIG. 17	FIG. 17

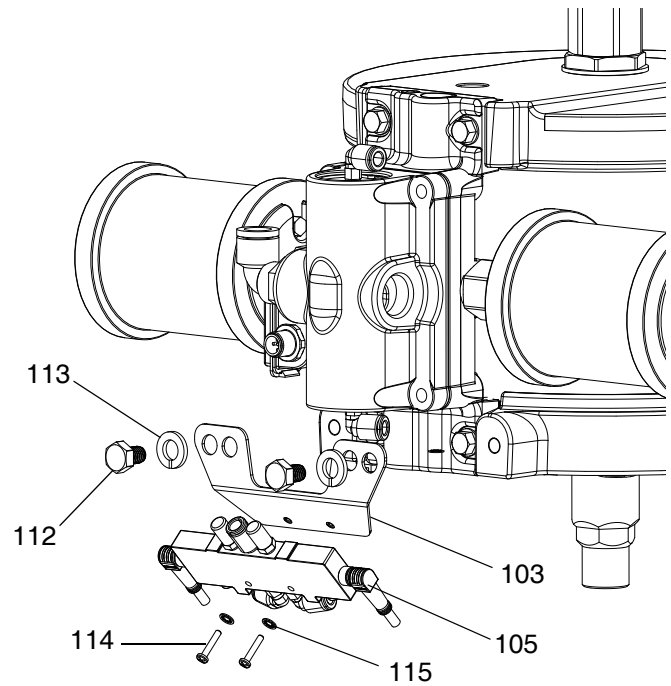

FIG. 17: Install Solenoid Valve Assembly

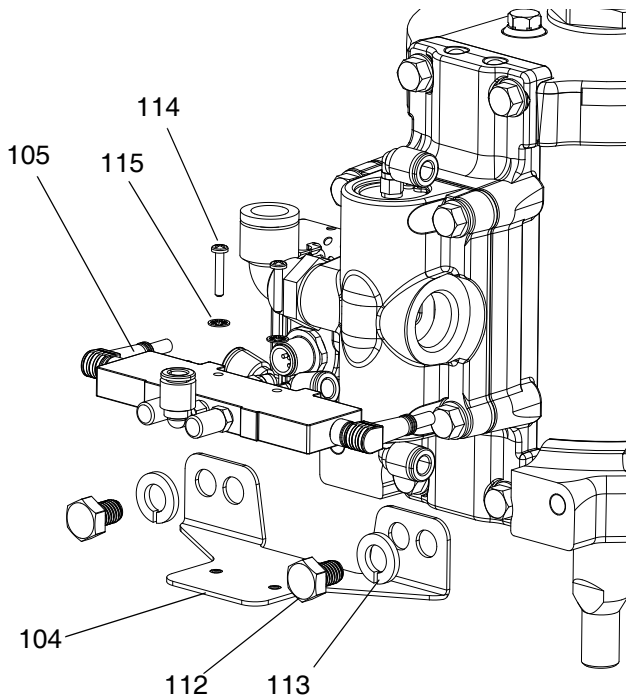

FIG. 16: Install Solenoid Valve Assembly

12. Connect cables and air lines as shown in FIG. 18. Cut air line tubes to length.
13. Tee into your existing air supply, upstream from any regulators, to provide air to the solenoid air supply. Ensure there is a minimum of 70 psi (0.49 MPa, 4.9 bar).

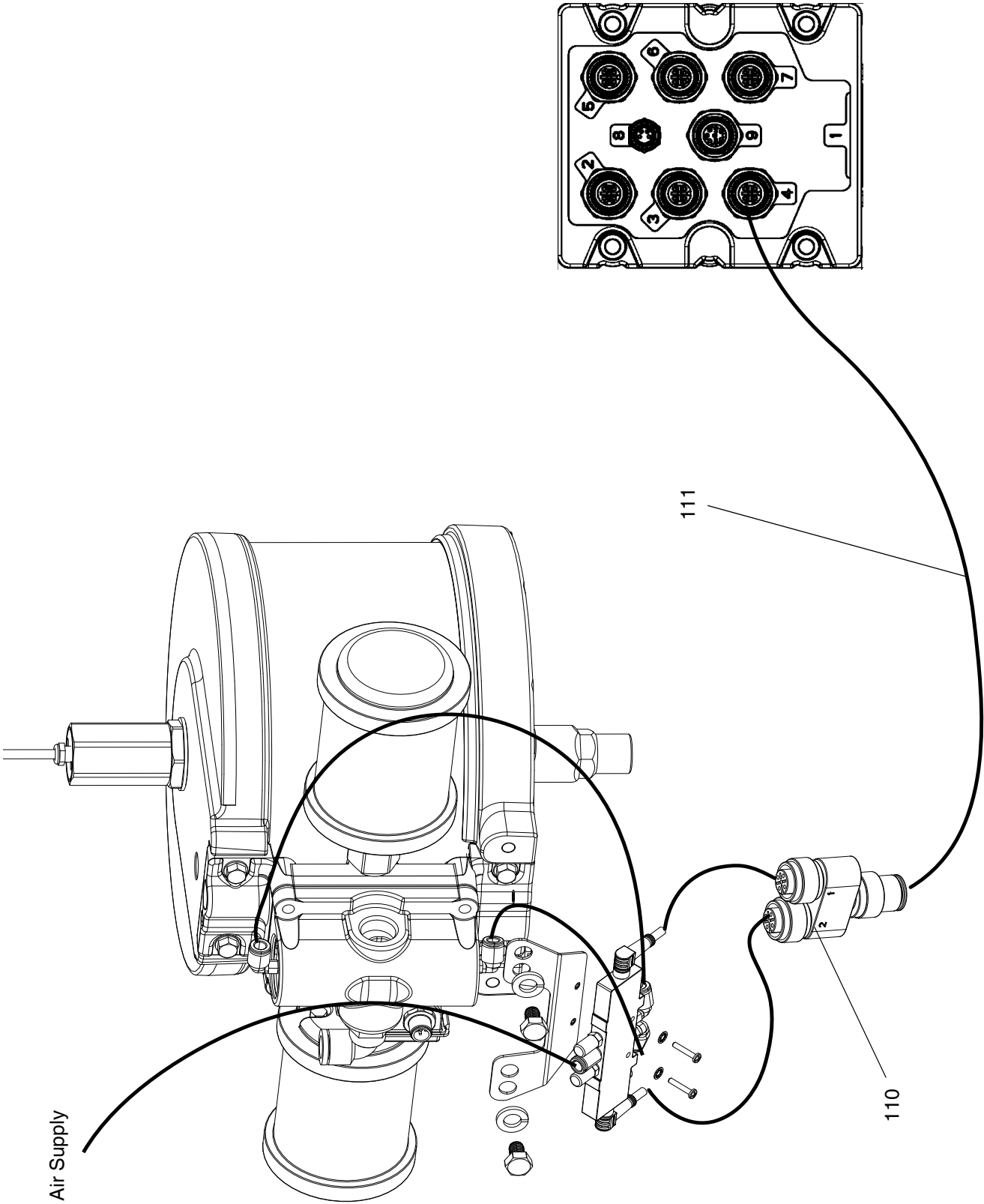

FIG. 18: Connect Cables and Air Line - NXT1800 and Smaller Air Motors

Parts

Kit 262453

For NXT2200 and larger air motors

Ref.	Part	Description	Qty
1	16F602	STOP, valve piston, ported	2
2		BRACKET, solenoid mount	1
3	16F612	VALVE, solenoid	1
4	124661	CABLE, changeover solenoid	2
5	124745	FITTING, elbow, swivel; 10-32x1/4	2
6	124746	FITTING, straight; 10-32x1/4	1
7	124795	MUFFLER; 10-32 thread	2
8	124273	CONNECTOR, splitter	1
9	124415	CABLE; 5 pin, mf, 3.0m	1
10	107257	SCREW, thread forming	2
11	115814	WASHER, flat, sst	2
12	107390	SCREW, machined, pan head	2
13	100272	WASHER, lock	2
14	108014	O-RING	2
15	C19405	FITTING, connector, male	1
16	C12509	TUBE; nylon, round, 15 ft.	-
18	103473	STRAP, tie, wire	8
20	112698	ELBOW, male, swivel	1

Kit 262464

For NXT1800 and smaller air motors

Ref.	Part	Description	Qty
101	16F837	PLUG, air valve, ported, small	2
102	16F839	PLUG, air valve, ported, medium	2
103		BRACKET, solenoid mount	1
104		BRACKET, solenoid mount	1
105	16F612	VALVE, solenoid	1
106	124661	CABLE, changeover solenoid	2
107	124745	FITTING, elbow, swivel; 10-32x1/4	5
108	124746	FITTING, straight; 10-32x1/4	1
109	124795	MUFFLER; 10-32 thread	2
110	124273	CONNECTOR, splitter	1
111	124415	CABLE; 5 pin, mf, 3.0m	1
112	15V909	SCREW; m8 x 12	2
113	100133	WASHER, lock	2
114	107390	SCREW, machined, pan head	2
115	100272	WASHER, lock	2
116	514279	O-RING; 018 buna	2
117	103255	O-RING	2
118	15M269	RING, snap, internal	2
119	15M271	RING, retaining	2
120	C12509	TUBE; nylon, round, 15 ft.	-
122	103473	STRAP, tie, wire	8

Graco Standard Warranty

Graco warrants all equipment referenced in this document which is manufactured by Graco and bearing its name to be free from defects in material and workmanship on the date of sale to the original purchaser for use. With the exception of any special, extended, or limited warranty published by Graco, Graco will, for a period of twelve months from the date of sale, repair or replace any part of the equipment determined by Graco to be defective. This warranty applies only when the equipment is installed, operated and maintained in accordance with Graco's written recommendations.

This warranty does not cover, and Graco shall not be liable for general wear and tear, or any malfunction, damage or wear caused by faulty installation, misapplication, abrasion, corrosion, inadequate or improper maintenance, negligence, accident, tampering, or substitution of non-Graco component parts. Nor shall Graco be liable for malfunction, damage or wear caused by the incompatibility of Graco equipment with structures, accessories, equipment or materials not supplied by Graco, or the improper design, manufacture, installation, operation or maintenance of structures, accessories, equipment or materials not supplied by Graco.

This warranty is conditioned upon the prepaid return of the equipment claimed to be defective to an authorized Graco distributor for verification of the claimed defect. If the claimed defect is verified, Graco will repair or replace free of charge any defective parts. The equipment will be returned to the original purchaser transportation prepaid. If inspection of the equipment does not disclose any defect in material or workmanship, repairs will be made at a reasonable charge, which charges may include the costs of parts, labor, and transportation.

THIS WARRANTY IS EXCLUSIVE, AND IS IN LIEU OF ANY OTHER WARRANTIES, EXPRESS OR IMPLIED, INCLUDING BUT NOT LIMITED TO WARRANTY OF MERCHANTABILITY OR WARRANTY OF FITNESS FOR A PARTICULAR PURPOSE.

Graco's sole obligation and buyer's sole remedy for any breach of warranty shall be as set forth above. The buyer agrees that no other remedy (including, but not limited to, incidental or consequential damages for lost profits, lost sales, injury to person or property, or any other incidental or consequential loss) shall be available. Any action for breach of warranty must be brought within two (2) years of the date of sale.

GRACO MAKES NO WARRANTY, AND DISCLAIMS ALL IMPLIED WARRANTIES OF MERCHANTABILITY AND FITNESS FOR A PARTICULAR PURPOSE, IN CONNECTION WITH ACCESSORIES, EQUIPMENT, MATERIALS OR COMPONENTS SOLD BUT NOT MANUFACTURED BY GRACO. These items sold, but not manufactured by Graco (such as electric motors, switches, hose, etc.), are subject to the warranty, if any, of their manufacturer. Graco will provide purchaser with reasonable assistance in making any claim for breach of these warranties.

In no event will Graco be liable for indirect, incidental, special or consequential damages resulting from Graco supplying equipment hereunder, or the furnishing, performance, or use of any products or other goods sold hereto, whether due to a breach of contract, breach of warranty, the negligence of Graco, or otherwise.

FOR GRACO CANADA CUSTOMERS

The Parties acknowledge that they have required that the present document, as well as all documents, notices and legal proceedings entered into, given or instituted pursuant hereto or relating directly or indirectly hereto, be drawn up in English. Les parties reconnaissent avoir convenu que la rédaction du présente document sera en Anglais, ainsi que tous documents, avis et procédures judiciaires exécutés, donnés ou intentés, à la suite de ou en rapport, directement ou indirectement, avec les procédures concernées.

Graco Information

Sealant and Adhesive Dispensing Equipment

For the latest information about Graco products, visit www.graco.com.

For patent information, see www.graco.com/patents.

TO PLACE AN ORDER, contact your Graco distributor, go to www.graco.com and select "Where to Buy" in the top blue bar, or call to find the nearest distributor.

If calling from the US: 800-746-1334

If calling from outside the US: 0-1-330-966-3000

All written and visual data contained in this document reflects the latest product information available at the time of publication. Graco reserves the right to make changes at any time without notice.

Original instructions. This manual contains English. MM 3A1162

Graco Headquarters: Minneapolis

International Offices: Belgium, China, Japan, Korea

GRACO INC. P.O. BOX 1441 MINNEAPOLIS, MN 55440-1441

Copyright 2010, Graco Inc. is registered to ISO 9001

www.graco.com

Revision B, February 2017