

INSTRUCTIONS-PARTS LIST



308-807

Rev. B
Supersedes A



This manual contains important warnings and information.
READ AND KEEP FOR REFERENCE.

INSTRUCTIONS

First choice when
quality counts.™

Ultra-Lite™ In-Line Flow Gun

3400 psi (23.4 MPa, 234 bar) Maximum Working Pressure

Model 240-199
With Ball End Needle

Model 240-200
With Tapered Needle

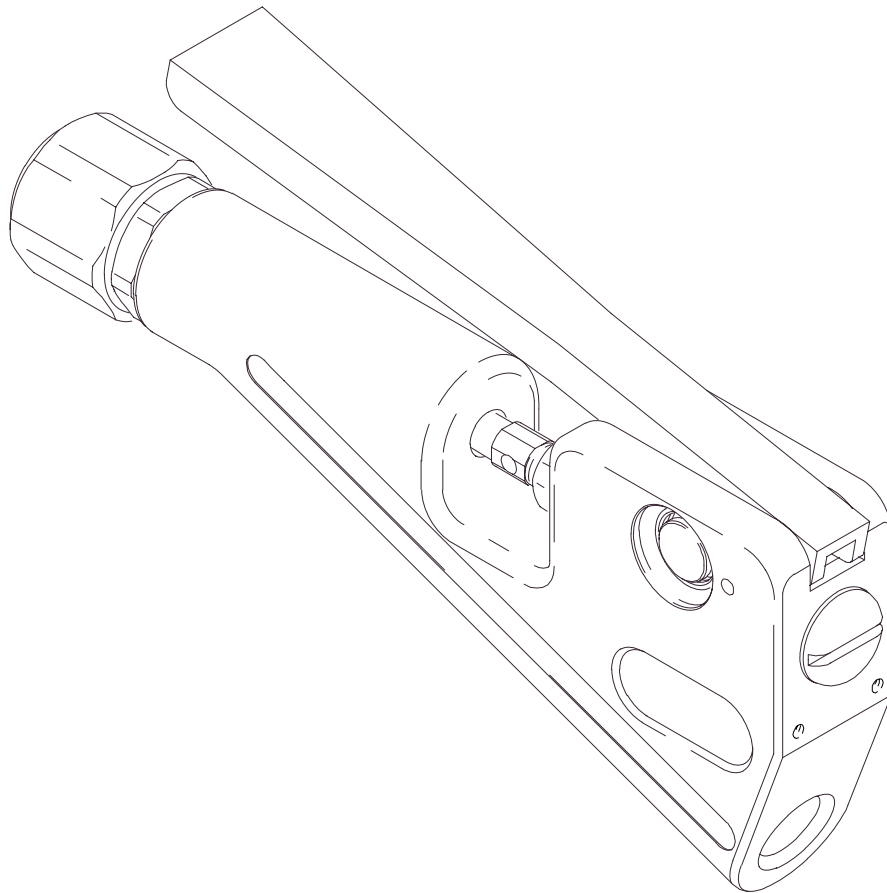

7903A

Table of Contents

Warnings	2
Installation	4
Operation	5
Service	6
Parts	7
Technical Data	8
Warranty	12
Graco Phone Numbers	12

Symbols

Warning Symbol



This symbol alerts you to the possibility of serious injury or death if you do not follow the corresponding instructions.

Caution Symbol



This symbol alerts you to the possibility of damage to or destruction of equipment if you do not follow the corresponding instructions.

! WARNING



INJECTION HAZARD

Spray from the gun, hose leaks, or ruptured components can inject fluid into your body and cause an extremely serious injury, including the need for amputation. Splashing fluid in the eyes or on the skin can also cause a serious injury.

- Fluid injected into the skin might look like just a cut, but it is a serious injury. **Get immediate medical attention.**
- Do not point the gun at anyone or at any part of the body.
- Do not put your hand or fingers over the gun nozzle.
- Do not stop or deflect leaks with your hand, body, glove or rag.
- Do not “blow back” fluid; this is not an air spray system.
- Be sure the gun trigger safety operates before dispensing.
- Lock the gun trigger safety when you stop dispensing.
- Follow the **Pressure Relief Procedure** on page 5 if the gun nozzle clogs and before cleaning, checking or servicing the equipment.
- Tighten all fluid connections before operating the equipment.
- Check the hoses, tubes, and couplings daily. Replace worn, damaged, or loose parts immediately. Permanently coupled hoses cannot be repaired; replace the entire hose.



TOXIC FLUID HAZARD

Hazardous fluid or toxic fumes can cause serious injury or death if splashed in the eyes or on the skin, inhaled, or swallowed.

- Know the specific hazards of the fluid you are using.
- Store hazardous fluid in an approved container. Dispose of hazardous fluid according to all local, state and national guidelines.
- Always wear protective eyewear, gloves, clothing and respirator as recommended by the fluid and solvent manufacturer.

WARNING



INSTRUCTIONS

EQUIPMENT MISUSE HAZARD

Equipment misuse can cause the equipment to rupture or malfunction and result in serious injury.

- This equipment is for professional use only.
- Read all instruction manuals, tags, and labels before operating the equipment.
- Use the equipment only for its intended purpose. If you are uncertain about usage, call your Graco distributor.
- Do not alter or modify this equipment. Use only genuine Graco parts and accessories.
- Check equipment daily. Repair or replace worn or damaged parts immediately.
- Do not exceed the maximum working pressure of the lowest rated system component. This equipment has a **3400 psi (23.4 MPa, 234 bar) maximum working pressure**.
- Route hoses away from traffic areas, sharp edges, moving parts, and hot surfaces. Do not expose Graco hoses to temperatures above 66°C (150°F) or below -40°C (-40°F).
- Do not use the hoses to pull the equipment.
- Use only Graco approved hoses. Do not remove hose spring guards, which help protect the hose from rupture caused by kinks or bends near the couplings.
- Use fluids or solvents that are compatible with the equipment wetted parts. See the **Technical Data** section of all the equipment manuals. Read the fluid and solvent manufacturer's warnings.
- Never use 1.1.1-trichloroethane, methylene chloride, other halogenated hydrocarbon solvents or fluids containing such solvents in pressurized aluminum equipment. Such use could result in a chemical reaction, with the possibility of explosion.
- Comply with all applicable local, state, and national fire, electrical, and safety regulations.



FIRE AND EXPLOSION HAZARD

Improper grounding, poor ventilation, open flames or sparks can cause a hazardous condition and result in a fire or explosion and serious injury.

- Ground the equipment. Refer to **Grounding** on page 4.
- If there is any static sparking or you feel an electric shock while using this equipment, **stop dispensing immediately**. Do not use the equipment until you identify and correct the problem.
- Provide fresh air ventilation to avoid the buildup of flammable fumes from solvents or the fluid being dispensed.
- Keep the dispense area free of debris, including solvent, rags, and gasoline.
- Before operating this equipment, electrically disconnect all equipment in the dispense area.
- Before operating this equipment, extinguish all open flames or pilot lights in the dispense area.
- Do not smoke in the dispense area.
- Do not turn on or off any light switch in the dispense area while dispensing or while operating if fumes are present.
- Do not operate a gasoline engine in the dispense area.

Installation

Grounding

WARNING



FIRE AND EXPLOSION HAZARD

Before operating the pump, ground the system as explained below. Also read the section **FIRE AND EXPLOSION HAZARD** on page 3.



1. *Pump*: use a ground wire and clamp as shown in your separate pump manual.
2. *Fluid hoses*: use only electrically conductive fluid hoses with a maximum of 500 feet (150 m) combined hose length to ensure grounding continuity. Check the electrical resistance of your fluid hoses at least once a week. If your hose does not have a tag on it which specifies the maximum electrical resistance, contact the hose supplier or manufacturer for the maximum resistance limits. If the hose resistance exceeds the recommended limits, replace it immediately.
3. *Air compressors and hydraulic power supplies*: ground the equipment according to the manufacturer's recommendations.
4. *Flow gun*: ground through connection to a properly grounded fluid hose and pump.
5. *Fluid supply container*: Ground according to your local code.
6. *Flammable liquids in the dispensing area*: must be kept in approved, grounded containers. Do not store more than the quantity needed for one shift.
7. *Solvent pails used when flushing*: follow your local code. Use only metal pails, which are conductive, placed on a grounded surface. Do not place the pail on a nonconductive surface, such as paper or cardboard, which interrupts the grounding continuity.
8. *To maintain grounding continuity when flushing or relieving pressure*, hold a metal part of the gun firmly to the side of a grounded *metal* pail, then trigger the gun.

Operation

Pressure Relief Procedure

⚠ WARNING



INJECTION HAZARD
The system pressure must be manually relieved to prevent the system from starting or dispensing accidentally. Fluid under high pressure can be injected through the skin and cause serious injury. To reduce the risk of an injury from injection, splashing fluid, or moving parts, follow the **Pressure Relief Procedure** whenever you:

- are instructed to relieve the pressure,
- stop dispensing,
- check or service any of the system equipment,
- or install or clean the nozzle.

1. Fully release the gun trigger. Press the red button to lock the trigger safety. See Fig. 1.
2. Shut off the fluid supply pump.
3. Hold a metal part of the gun firmly to the side of a grounded metal pail. Press the silver button to unlock the trigger safety. Trigger the gun to relieve pressure.
4. Open the pump drain valve to help relieve pressure in the pump, hose, and gun. Triggering the gun to relieve pressure may not be sufficient. Have a container ready to catch the drainage.
5. Leave the drain valve open until you are ready to dispense again.
6. Fully release the gun trigger and lock the trigger safety.

Flow Rate Adjustment

⚠ WARNING

To reduce the risk of serious injury, whenever the gun is not in use, press the red button to lock the trigger safety. See Fig. 1.

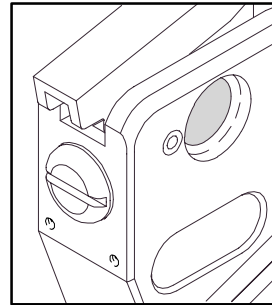

**Trigger Safety
Locked**

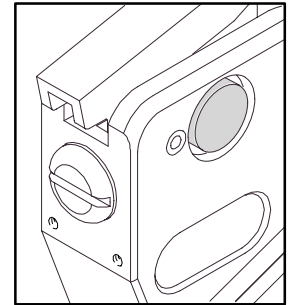

**Trigger Safety
Unlocked**

7901

Fig. 1

To dispense material, unlock the trigger safety, then fully squeeze the trigger. Flow begins with the slightest pressure and continues until the trigger is released.

NOTE: A minimum of 1 pint (0.5 liters) of material must be dispensed from the gun to remove all air from the system. If the air is not completely removed, slow shutoff may occur.

Adjust the pump to the minimum speed necessary to deliver the material at a satisfactory rate, or adjust the fluid/mastic regulator.

Lubrication and Care

Keep the gun clean, and oil the exposed portion of the needle with a light, high grade machine oil daily.

Service

NOTE: Repair kits are available. See page 7 for the kits for your gun model. For the best results, use all the new parts in the kit. Kit parts are marked with an asterisk, for example (2*).

NOTE: See the Parts Drawing on page 7 when disassembling and reassembling the gun.

Disassembly

WARNING

To reduce the risk of serious injury whenever you are instructed to relieve pressure, always follow the **Pressure Relief Procedure** on page 5.

1. **Relieve the pressure.**
2. Disconnect the gun from the hose.
3. Unscrew the nozzle nut (11) and nozzle (not shown) from the seat (5*).
4. Unlock the trigger safety. See Fig. 1.
5. Depress the trigger (3) and remove the seat (5*) from the gun.

CAUTION

Failure to depress the trigger while removing the seat may damage the needle.

6. Loosen the hexnut (12) on the needle (2*) while holding the adjustment screw (A) with a screwdriver.
7. Unscrew the needle (2*) by turning the adjustment screw (A) until the needle is unthreaded.
8. Remove the hexnut (12) and remove the needle (2*) through the front of the gun.

Reassembly

1. Apply grease to the needle (2*) o-rings.
2. Put the needle (2*) in the gun, screwing the hexnut (12) on the needle as it is going in.
3. Start threading the adjustment screw (A) until it engages the threads of the needle (2). Continue threading until the trigger (3) raises 1/2 in. (13 mm).
4. Grease the threads of the seat (5*) and the gasket (10*).
5. Press the trigger (3) and install the gasket (10*) and seat (5*).
6. Lift the trigger (3) and lock the trigger safety.
7. Trigger adjustment:
 - a. Turn the adjustment screw (A) clockwise until the trigger (3) travels as far up as possible.
 - b. Turn the adjustment screw (A) counterclockwise until the trigger (3) stops falling, then turn an additional 1/8 turn.
 - c. Tighten the hexnut (12) against the adjustment screw (A). Hold the adjustment screw (A) to prevent it from turning. Torque the hexnut to 18–22 in-lb (2.03–2.46 N•m).
 - d. Test the trigger safety (B) to ensure that it operates properly. If the trigger safety does not operate properly, loosen the hexnut (12) and return to step 7a.
8. Screw the nozzle nut (11) and nozzle (not shown) back onto the front of the gun.

Parts

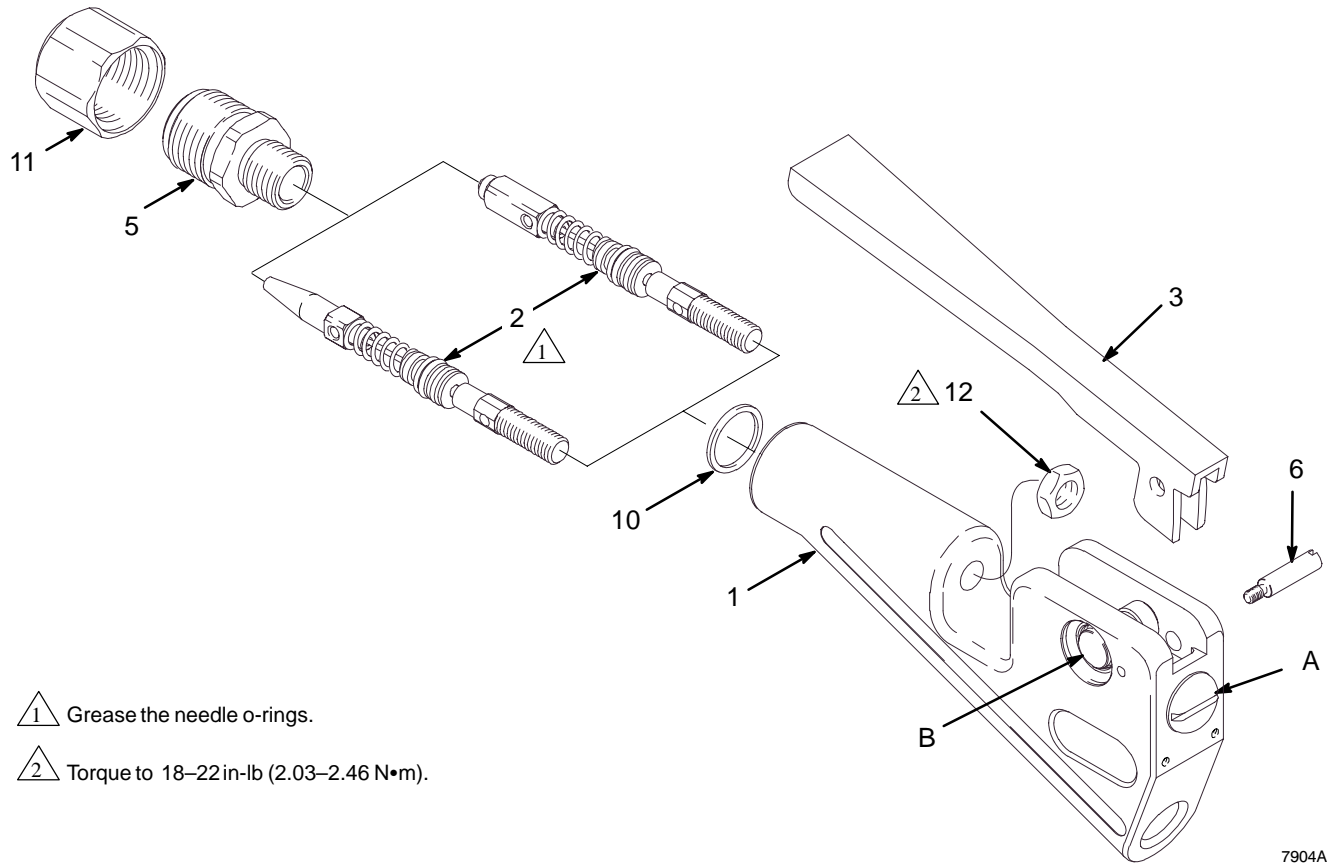

1 Grease the needle o-rings.

2 Torque to 18–22 in-lb (2.03–2.46 N•m).

Models 240–199 and 240–200

Ref No.	Part No.	Description	Qty
1	240–208	BODY, Flow Gun	1
2*	240–201	NEEDLE, 3/16 ball	1
	240–202	NEEDLE, tapered Model 240–199 only	1
		Model 240–200 only	1
3	114–330	TRIGGER	1
5*	240–204	SEAT, 3/16 ball	1
		Model 240–199 only	1
	240–205	SEAT, tapered needle Model 240–200 only	1
6	192–989	SCREW, pivot	1
10*	168–845	GASKET, copper	1
11	188–253	NUT, nozzle	1
12	114–357	NUT, hex	1

* Included in repair kit. Keep these parts on hand to reduce down-time.

Repair Kits

Kit No. and Description	Includes:		
	Ref. No.	Part No.	Description
240–206 For Model 240–199	2	240–201	NEEDLE, 3/16 ball
	5	240–204	SEAT
	10	168–845	GASKET
240–207 For Model 240–200	2	240–202	NEEDLE, tapered
	5	240–205	SEAT
	10	168–845	GASKET

Technical Data

Category	Data
Maximum working pressure	3400 psi (23.4 MPa, 234 bar)
Maximum temperature	120° F (49° C)
Flow rate at 2000 psi (14 MPa, 138 bar)*	<i>Model 240–199: 158 oz/min (4.5 kg/min)</i> <i>Model 240–200: 154 oz/min (4.4 kg/min)</i>
Outlet port size	1/4 npt(f) and flange
Inlet port size	1/4 npt(f)
Dry weight	<i>Model 240–199: 11.6 oz (325 gm)</i> <i>Model 240–200: 11.6 oz (325 gm)</i>
Length	5.9 in (15.0 cm)
Width	2.6 in (6.6 cm)
Thickness	0.85 in (2.16 cm)
Pressure vessel material	Aluminum
Pressure vessel ID	0.25 in (6.4 mm)
Gun seat diameter	<i>Model 240–199: 0.125 in (3.2 mm)</i> <i>Model 240–200: 0.203 in (5.2 mm)</i>
Needle seat type	<i>Model 240–199: Carbide ball</i> <i>Model 240–200: 7° Tapered carbide</i>
Inlet/outlet angle	20°
Trigger force – breakaway @ 1000 psi (7 MPa, 69 bar)	<i>Model 240–199: 1.6 lb (0.73 kg)</i> <i>Model 240–200: 3.8 lb (1.72 kg)</i>
Trigger force – breakaway @ 2000 psi (14 MPa, 138 bar)	<i>Model 240–199: 2.2 lb (1.0 kg)</i> <i>Model 240–200: 7.3 lb (3.31 kg)</i>
Trigger force – sustaining	<i>Model 240–199: 3.2 lb (1.45 kg)</i> <i>Model 240–200: 2.8 lb (1.27 kg)</i>
Wetted parts	Aluminum, stainless steel, carbide, polyethylene, CV75®

CV75® is a registered trademark of the International Seal Co., Inc.

* Flow rates were measured using PVC sealer dispensed through a 1/8 in. diameter orifice nozzle and z-swivel connected to inlet. Actual flow rates will vary depending on material type, fluid pressure, nozzle size, and system configuration.

Graco Standard Warranty

Graco warrants all equipment manufactured by Graco and bearing its name to be free from defects in material and workmanship on the date of sale by an authorized Graco distributor to the original purchaser for use. With the exception of any special, extended, or limited warranty published by Graco, Graco will, for a period of twelve months from the date of sale, repair or replace any part of the equipment determined by Graco to be defective. This warranty applies only when the equipment is installed, operated and maintained in accordance with Graco's written recommendations.

This warranty does not cover, and Graco shall not be liable for general wear and tear, or any malfunction, damage or wear caused by faulty installation, misapplication, abrasion, corrosion, inadequate or improper maintenance, negligence, accident, tampering, or substitution of non-Graco component parts. Nor shall Graco be liable for malfunction, damage or wear caused by the incompatibility of Graco equipment with structures, accessories, equipment or materials not supplied by Graco, or the improper design, manufacture, installation, operation or maintenance of structures, accessories, equipment or materials not supplied by Graco.

This warranty is conditioned upon the prepaid return of the equipment claimed to be defective to an authorized Graco distributor for verification of the claimed defect. If the claimed defect is verified, Graco will repair or replace free of charge any defective parts. The equipment will be returned to the original purchaser transportation prepaid. If inspection of the equipment does not disclose any defect in material or workmanship, repairs will be made at a reasonable charge, which charges may include the costs of parts, labor, and transportation.

THIS WARRANTY IS EXCLUSIVE, AND IS IN LIEU OF ANY OTHER WARRANTIES, EXPRESS OR IMPLIED, INCLUDING BUT NOT LIMITED TO WARRANTY OF MERCHANTABILITY OR WARRANTY OF FITNESS FOR A PARTICULAR PURPOSE.

Graco's sole obligation and buyer's sole remedy for any breach of warranty shall be as set forth above. The buyer agrees that no other remedy (including, but not limited to, incidental or consequential damages for lost profits, lost sales, injury to person or property, or any other incidental or consequential loss) shall be available. Any action for breach of warranty must be brought within two (2) years of the date of sale.

Graco makes no warranty, and disclaims all implied warranties of merchantability and fitness for a particular purpose in connection with accessories, equipment, materials or components sold but not manufactured by Graco. These items sold, but not manufactured by Graco (such as electric motors, switches, hose, etc.), are subject to the warranty, if any, of their manufacturer. Graco will provide purchaser with reasonable assistance in making any claim for breach of these warranties.

In no event will Graco be liable for indirect, incidental, special or consequential damages resulting from Graco supplying equipment hereunder, or the furnishing, performance, or use of any products or other goods sold hereto, whether due to a breach of contract, breach of warranty, the negligence of Graco, or otherwise.

FOR GRACO CANADA CUSTOMERS

The parties acknowledge that they have required that the present document, as well as all documents, notices and legal proceedings entered into, given or instituted pursuant hereto or relating directly or indirectly hereto, be drawn up in English. Les parties reconnaissent avoir convenu que la rédaction du présente document sera en Anglais, ainsi que tous documents, avis et procédures judiciaires exécutés, donnés ou intentés à la suite de ou en rapport, directement ou indirectement, avec les procédures concernées.

Graco Phone Number

TO PLACE AN ORDER, contact your Graco distributor, or call this number to identify the distributor closest to you:
1-800-367-4023 Toll Free

*All written and visual data contained in this document reflects the latest product information available at the time of publication.
Graco reserves the right to make changes at any time without notice.*

Sales Offices: Minneapolis, Detroit, Los Angeles
Foreign Offices: Belgium, Canada, England, Korea, France, Germany, Hong Kong, Japan

GRACO INC. P.O. BOX 1441 MINNEAPOLIS, MN 55440-1441
<http://www.graco.com>

©1998-1997 Graco Inc. 308-807 Rev. B April 1998 PRINTED IN U.S.A.

Parts Change Notice

Some parts in Rev. B of manual 308-807 have changed but have not yet been changed in the instruction manual. Please note the changes below and mark them in your manual or keep this sheet with your manual.

Assembly No.	Series Letter Change	Part That Changed	Ref No.	Part Description	Description of Change
All Models	B	114-330	3	Trigger	Replaced by Part No. 194-983 Trigger

Other Changes

Page 1: Add: For use with fluids of viscosity less than 150,000 cps.

Before the Service Section: Add the following **Troubleshooting Chart:**

PROBLEM	CAUSE	SOLUTION
When using a small orifice wand (approximately .040 in. diameter), 1/4 to 3/4 in. of material continues to flow from the outlet of the wand immediately after releasing the trigger.	Air is trapped in the wand.	Purge all air from the wand. Helpful Tip: To verify that air is trapped in the wand, trigger the gun, then quickly shut off the material supply, relieve pressure in the gun, and promptly remove the gun from the supply hose. Then, without triggering the gun, lay it on a bench and observe if material continues to flow very slowly from the outlet of the wand (approximately 0.1 in. per minute from a .050 in. orifice). If this occurs, there is air trapped in the wand.
Popping, snapping, spitting, gaps, or irregularities in the material stream as it flows from the wand.	Air in the material.	Dispense material from the gun/wand until the popping, snapping, and spitting has stopped and the bead/extrusion is smooth and uninterrupted.
Gun does not shutoff completely.	Needle is not fully seating.	Readjust the trigger as described in steps 6 and 7 under Reassembly , on page 6 of your manual.



All written and visual data contained in this document reflects the latest product information available at the time of publication. Graco reserves the right to make changes at any time without notice.