

Fluid Automation F4 Series Fluid Control Module Kit

3A3171B

EN

For replacing Fluid Control Modules on the Fluid Automation F4 series models. For professional use only.

Not approved for use in explosive atmospheres or hazardous locations.

Kit No. 25A172



Important Safety Instructions

Read all warnings and instructions in this manual and in all related manuals as shown on page 2. Save all instructions.

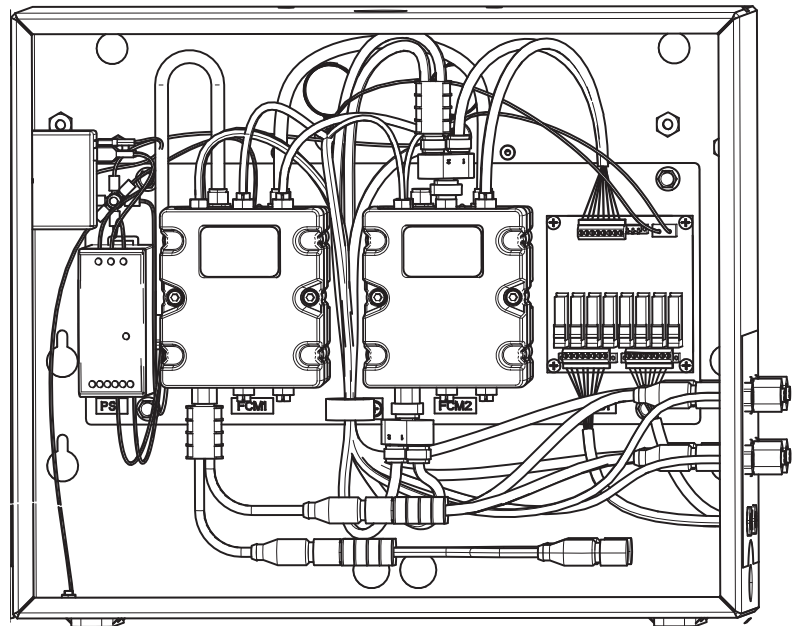

Contents

Related Manuals 2
Overview 2
Part Numbers for Kit 25A172 3
Installation 4
 Pressure Relief Procedure 4
 Shutdown 5
 Remove the Current FCM 5
 Install the New FCM 6
 Update the Software 6
Graco Information 8

Related Manuals

Part	Description
335028	Fluid Automation F4 Series Instructions - Setup-Operation
3A1244	Graco Control Architecture™ Module Programming

Overview

Kit no. 25A172 is used when replacing Fluid Control Modules (FCMs) on the Fluid Automation F4-5 and F4-55. These instructions describe:

- Removing the FCM currently installed on the machine.
- Installing the replacement FCM included in this kit.
- Upgrading the software to the system so the new FCM functions successfully.

Part Numbers for Kit 25A172

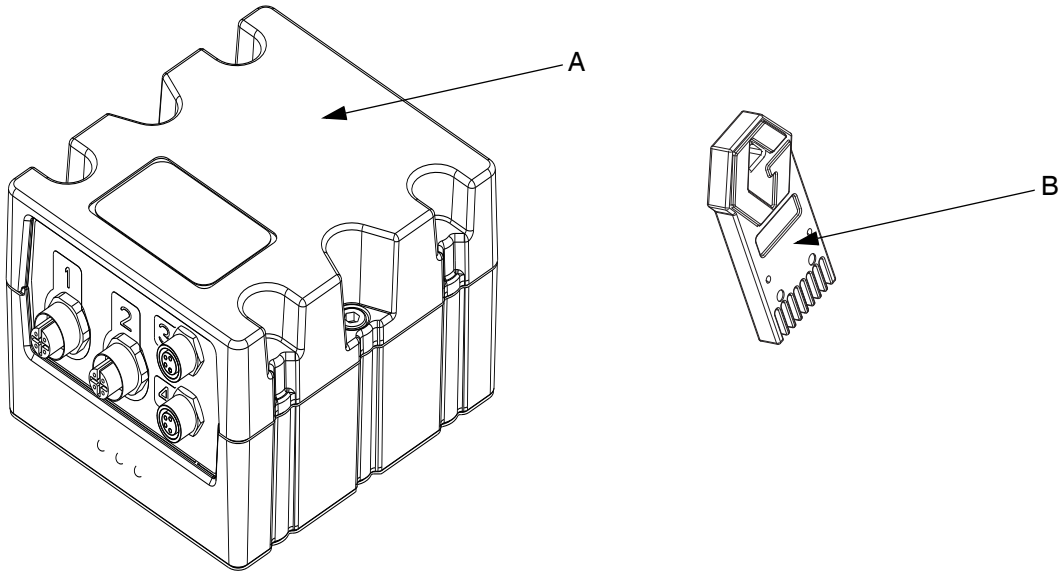

Ref	Part	Description	Qty
A	289696	MODULE, gca, cube, fcm	1
B	17C706	TOKEN, gca, upgrade, lsr	1

Installation

! WARNING

SKIN INJECTION HAZARD

High pressure fluid from dispensing devices, hose leaks, or ruptured components will pierce skin. Follow the Pressure Relief Procedure.

TOXIC FLUID OR FUMES HAZARD

Toxic fluids or fumes can cause serious injury or death if splashed in the eyes or on skin, inhaled, or swallowed.

MOVING PARTS HAZARD

Moving parts can pinch, cut or amputate fingers, and other body parts.

PERSONAL PROTECTIVE EQUIPMENT

Wear appropriate equipment when in the work area to help prevent serious injury.

NOTE: This procedure relieves air pressure from the entire system.

1. To relieve pressure at the pump, turn off the system air slider valve.

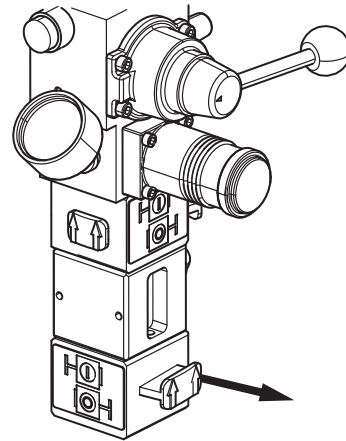

Pressure Relief Procedure

! WARNING



The F4 series equipment stays pressurized until pressure is manually relieved. To help prevent serious injury from pressurized fluid, such as skin injection, splashing fluid, and moving parts, follow the Pressure Relief Procedure when you stop dispensing and before cleaning, checking, or servicing the equipment.

NOTICE

An empty container should always be placed under the prime valve and the ratio check valve openings before using them to keep material from dispensing onto the machine.

2. Open the prime ball valves for both the A and B pumps.

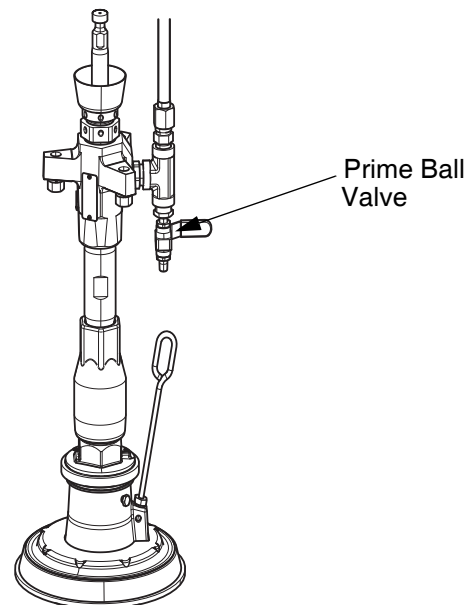

3. To relieve pressure on the side leading out to the stack from the dosing valves, open the material out let valve on both the A and B side.

NOTE: There is pressure on each side of both the A and B dosing valves on the F4-5 and F4-55. Pressure must be relieved on the pump side and the stack side of the dosing valves.

4. Open the ratio check valve on both the A and B side to relieve pressure

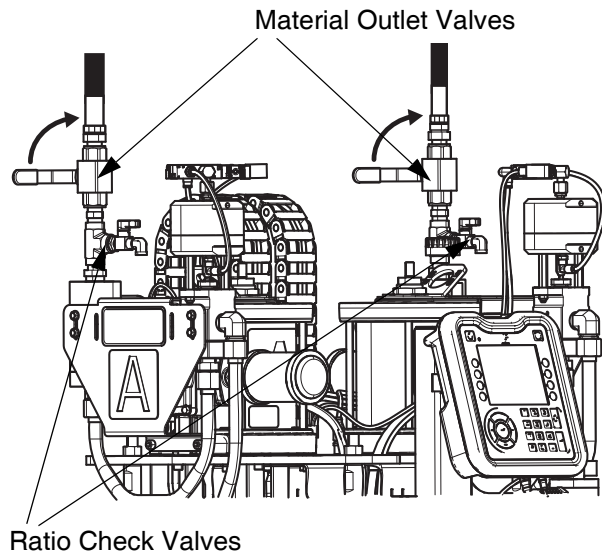

Shutdown



Perform the following steps to shut down the machine before proceeding with replacement of an FCM.

1. Perform the Pressure Relief Procedure as described on this page.
2. After you complete the procedure, turn off the power at the electrical enclosure.

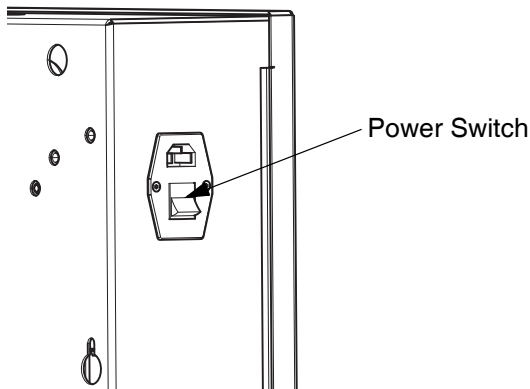

Remove the Current FCM

There are two FCMs used by the F4-5 and F4-55. They are located in the electrical enclosure.

1. Open the electrical enclosure's door. FCM #1 is on the left and FCM #2 is on the right.

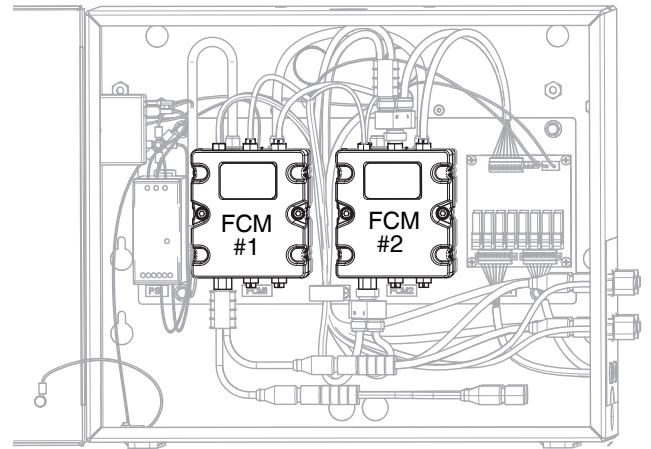

2. Disconnect all cables from the ports of the FCM that needs to be replaced.

NOTE: Refer to the Fluid Automation F4 Series Setup-Operation Instructions, manual 335028, for information about the connections to the ports.

3. Remove the two screws on the sides of the FCM.
4. Detach the FCM from the base.

NOTE: The base remains attached to the electrical enclosure. Only the fluid control module (part #289696) is removed.

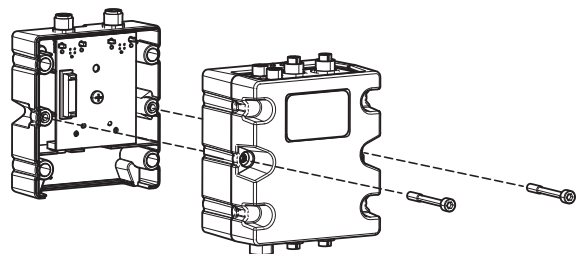

Install the New FCM

1. Align the replacement FCM's connector with the connector on the base that is still attached to the electrical enclosure and carefully press them together.
2. Insert and tighten the screws to fasten the module to the base.
3. Reconnect the cables to the appropriate ports on the new FCM. See the Fluid Automation F4 Series Setup-Operation Instructions, manual 335028, for the correct connections.
4. Note the serial number of the new FCM. This is found on the label located on the top of the module. You need this when updating the software.

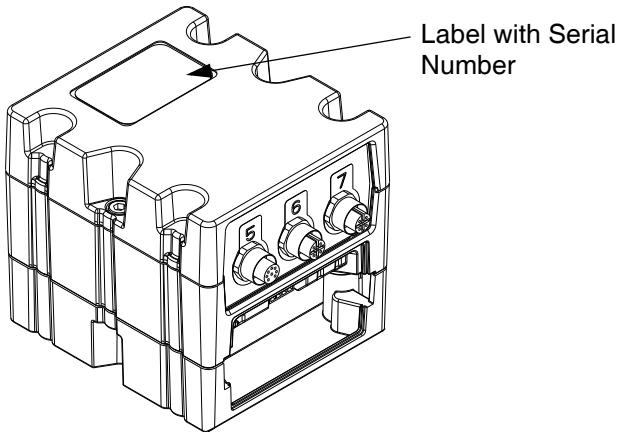

Update the Software

When software is updated on the Advanced Display Module (ADM), the software is then automatically updated on all connected Graco Control Architecture (GCA) components. Follow these instructions to upgrade the software on the ADM and the FCMs.

1. Turn off the power to the F4 series machine.
2. Remove the ADM from the bracket.
3. Use a hex wrench to remove the screw from the token access cover.
4. Remove the access cover.
5. Insert and press the software upgrade token firmly into the slot.

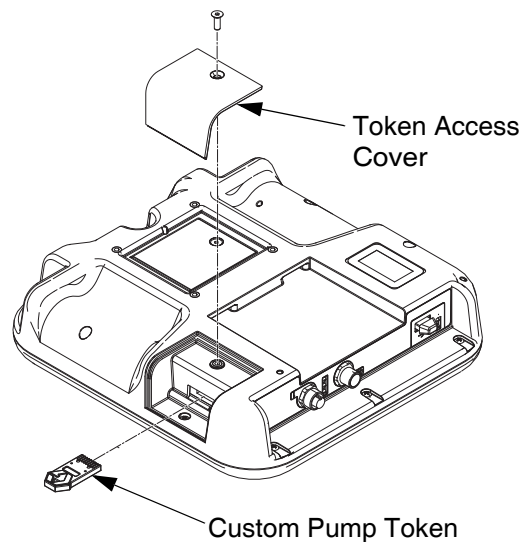

6. Turn on the power to the machine.

NOTE: To make selections at the ADM, use the directional keypad to navigate to the field you want to change. Press the  key to confirm your selection.

NOTICE

To prevent damage to soft key buttons, do not press the buttons with sharp objects such as pens, plastic cards, or fingernails.

7. The Graco splash screen is displayed until communication with other modules is established.



8. Once communication has been established, you need to select which software is applied to each Fluid Control Module.

NOTICE

The two FCMs control different functions. It is important that you do not install the software for FCM #1 into FCM #2 and vice versa. Installing the wrong software into an FCM during this procedure causes the machine to function improperly and may require assistance from Graco Technical Support.

NOTE: If the new FCM was placed in the **left side** (#1) of the electrical enclosure, the value in the software box should be **17C703**. If the FCM was placed in the **right side** (#2) of the enclosure, the value in the box should be **17C704**. See Remove the Current FCM on page 5.

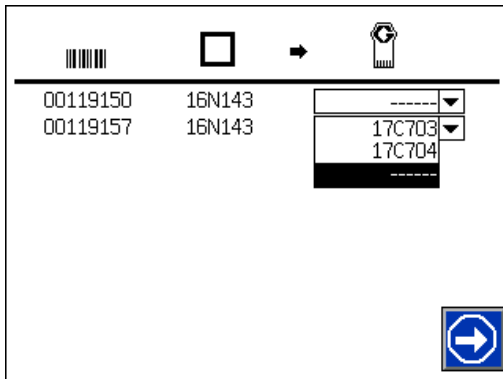

9. Using the ADM's keypad:
 - a. On the left side of the screen, identify the serial number for the FCM.

- b. Select the pull down menu located on the right side of the screen.
- c. Select the corresponding software position value.
- d. Repeat steps a through c for the other FCM.
- e. Press the key on the ADM when completed.

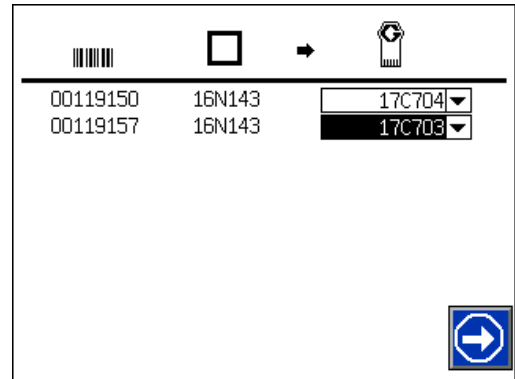

10. A software status screen shows the progress of the software update and the approximate time to completion. When the software update is completed successfully, press to continue.

NOTICE

To prevent corrupting the software load, do not remove the token, turn off system power, or disconnect any modules until the status screen indicates that the updates are complete.

11. Turn off the power to the machine.
12. Remove the software upgrade token.
13. Replace the token access cover. Insert and tighten the screw that holds it in place.
14. Mount the ADM on the bracket.

NOTE: See the Fluid Automation F4 Series Setup-Operation Instructions, manual 335028, for information regarding operation of the F4-5 and F4-55.

Graco Information

Sealant and Adhesive Dispensing Equipment

For the latest information about Graco products, visit www.graco.com.

For patent information, see www.graco.com/patents.

TO PLACE AN ORDER, contact your Graco distributor, go to www.graco.com and select “Where to Buy” in the top blue bar, or call to find the nearest distributor.

If calling from the US: 800-746-1334

If calling from outside the US: 0-1-330-966-3000

*All written and visual data contained in this document reflects the latest product information available at the time of publication.
Graco reserves the right to make changes at any time without notice.*

Original instructions. This manual contains English. MM 3A3171

Graco Headquarters: Minneapolis

International Offices: Belgium, China, Japan, Korea

GRACO INC. P.O. BOX 1441 MINNEAPOLIS, MN 55440-1441

Copyright 2015, Graco Inc. is registered to ISO 9001

www.graco.com

Revision B, February 2017