

Therm-O-Flow[®] Automatic Dispense Valves

310538T
EN

Air-operated dispense valves. For professional use only.



Important Safety Instructions

Read all warnings and instructions in this manual.
Save these instructions.

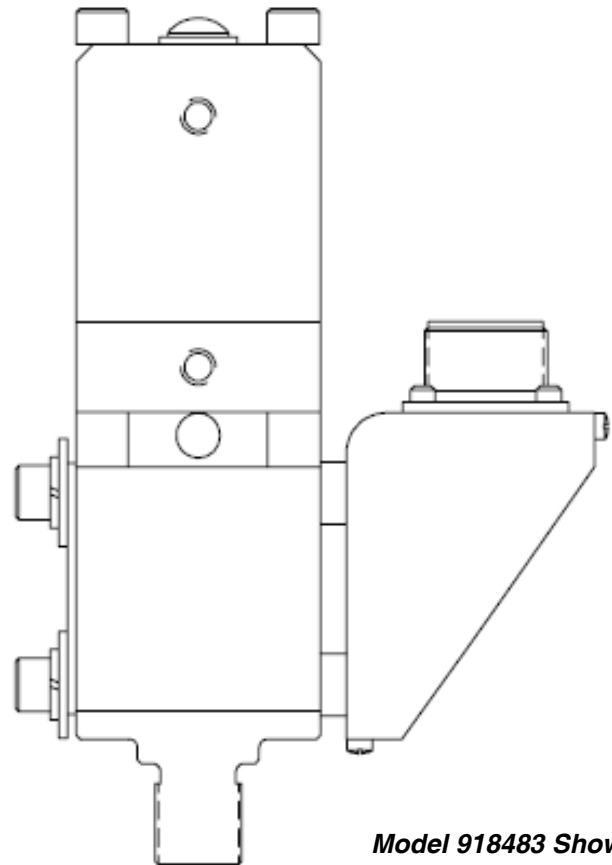

Model 918483 Shown

Table of Contents

Table of Contents	2	Parts	19
List of Models	2	Model 194485, Warm (275°F/135°C max) Automatic Dispense Valve with Snuff Back	19
Warnings	3	Model 918483, Therm-O-Flow Automatic Dispense Valve with Snuff Back	21
Installation	6	Model 918512, Ambient Therm-O-Flow Automatic Dispense Valve with Snuff Back	23
Mount the Automatic Dispense Valve	6	Model 918639, Therm-O-Flow Automatic Dispense Valve with Snuff Back	25
Attach the Dispense Tip, Nozzle, or Swirl	6	Model 243694, Therm-O-Flow Automatic Dispense Valve	27
Connect the Air Lines to the Dispense Valve	8	Model 297266, Automatic Hot Melt Swirl Dispense Valve	29
Grounding	9	Model 243695, Therm-O-Flow Automatic Dispense Valve	31
Troubleshooting	10	Model 243696, Therm-O-Flow Automatic Dispense Valve with Snuff Back	33
Service	11	Model C27340, Ambient Therm-O-Flow Automatic Dispense Valve, Double Acting	35
Pressure Relief Procedure	11	Model C34068, Warm Automatic Dispense Valve, Double Acting	37
Prepare to Service Automatic Dispense Valve	12	Model C34079, Therm-O-Flow Automatic Dispense Valve, Double Acting	39
Service the Automatic Dispense Valve	13	Model C50592, Therm-O-Flow Automatic Dispense Valve, Double Acting	41
Disconnect the Automatic Dispense Valve from the Mounting Bracket	13	Accessories	43
Reconnect the Automatic Dispense Valve to the Mounting Bracket	13	Dimensions	45
Disassemble the Automatic Dispense Valve	14	Technical Data	47
Reassemble the Automatic Dispense Valve	15	Graco Standard Warranty	48
Replace the Heater Unit or Sensor	16		
Inspection Frequency	18		

List of Models

Valve Type	Part No.	Type	Voltage / No. of Pins	Maximum Fluid Working Pressure	Maximum Air Input Pressure	Parts Page
TOF	194485	Snuff Back	120 V / 6	241 bar, 24 MPa (3500 psi)	10 bar, 1 MPa (150 psi)	20
TOF	918483	Snuff Back	120 V / 6	241 bar, 24 MPa (3500 psi)	10 bar, 1 MPa (150 psi)	22
	918512	Snuff Back	Ambient	241 bar, 24 MPa (3500 psi)	10 bar, 1 MPa (150 psi)	24
TOF	918639	Snuff Back	120 V / 6	241 bar, 24 MPa (3500 psi)	10 bar, 1 MPa (150 psi)	26
TOF+	243694	Base Seal	240 V / 8	241 bar, 24 MPa (3500 psi)	10 bar, 1 MPa (150 psi)	28
TOF 200	297266	Snuff Back Swirl	240 V / 8	241 bar, 24 MPa (3500 psi)	10 bar, 1 MPa (150 psi)	30
TOF+	243695	Base Seal H. F.	240 V / 8	241 bar, 24 MPa (3500 psi)	10 bar, 1 MPa (150 psi)	31
TOF+	243696	Snuff Back	240 V / 8	241 bar, 24 MPa (3500 psi)	10 bar, 1 MPa (150 psi)	33
TOF	C27340	Base Seal	Ambient	241 bar, 24 MPa (3500 psi)	10 bar, 1 MPa (150 psi)	35
TOF	C34068	Base Seal	120 V / 6	241 bar, 24 MPa (3500 psi)	10 bar, 1 MPa (150 psi)	37
TOF	C34079	Base Seal	120 V / 6	241 bar, 24 MPa (3500 psi)	10 bar, 1 MPa (150 psi)	39
TOF	C50592	Base Seal	120 V / 6	241 bar, 24 MPa (3500 psi)	10 bar, 1 MPa (150 psi)	41

Warnings

The following Warnings are for the safe setup, use, grounding, maintenance, and repair of this equipment. The exclamation point symbol alerts you to a general warning and the hazard symbols refer to procedure-specific risks. Refer back to these Warnings. Additional product-specific warnings may be found throughout the body of this manual where applicable.

WARNING



INSTRUCTIONS



EQUIPMENT MISUSE HAZARD

Equipment misuse can cause the equipment to rupture, malfunction, or start unexpectedly and result in serious injury.

- This equipment is for professional use only.
- Read all instruction manuals, warnings, tags, and labels before operating the equipment.
- Use the equipment only for its intended purpose. If you are uncertain, call your Graco distributor.
- Do not alter or modify this equipment. Use only genuine Graco parts and accessories.
- Check the equipment daily. Repair or replace worn or damaged parts immediately.
- Do not exceed the maximum air working pressure of 1 MPa (10 bar, 150 psi) to the applicator.
- Do not exceed the maximum fluid working pressure of 24 MPa (241 bar, 3500 psi) to the applicator or manifold.
- Never exceed the recommended working pressure or the maximum air inlet pressure stated on your pump or in the **Technical Data** on page 47.
- Be sure that all spray/dispensing equipment and accessories are rated to withstand the maximum working pressure of the pump. Do not exceed the maximum working pressure of any component or accessory used in the system.
- Route hoses away from traffic areas, sharp edges, moving parts, and hot surfaces.
- Do not expose Graco standard hoses to temperatures above 180F (82C) or below -40F (-40C). Do not expose Graco electrically heated hoses to temperatures above 400° F (222° C) or below -40F (-40C).
- Do not expose Graco standard hoses to temperatures above 180F (82C) or below -40F (-40C).
- Do not use the hoses to pull the equipment.
- Use only fluids and solvents that are compatible with the equipment wetted parts. See the **Technical Data** sections of all the equipment manuals. Read the fluid manufacturer's warnings.
- Always wear protective eyewear, gloves, clothing, and respirator as recommended by the fluid and solvent manufacturers.
- Wear hearing protection when operating this equipment.
- Comply with all applicable local, state and national fire, electrical and other safety regulations.

! WARNING



HOT SURFACE AND FLUID HAZARD

Heated fluid can cause severe burns and can cause equipment surfaces to become very hot.

- Wear protective gloves and clothing when operating this equipment in a heated system.
- Do not touch the metal heat sink when the surface is hot.
- Allow the equipment to cool thoroughly before servicing.

Some heated systems are designed to dispense Polyurethane (PUR) heated materials. PUR systems are supplied with ventilation hoods, and require proper ventilation and specially designed system components.



SKIN INJECTION HAZARD

Spray from the applicator, hose leaks, or ruptured components can inject fluid into your body and cause extremely serious injury, including the need for amputation. Fluid splashed in the eyes or on the skin can also cause serious injury.

- Fluid injected into the skin might look like just a cut, but it is a serious injury. **Get immediate surgical treatment.**
- Do not point the applicator at anyone or at any part of the body.
- Do not put hand or fingers over the front of the applicator.
- Do not stop or deflect fluid leaks with your hand, body, glove, or rag.
- Follow the **Pressure Relief Procedure** on page 11 whenever you are instructed to: relieve pressure; stop dispensing; clean, check, or service the equipment; or install or clean a tip or nozzle.
- Tighten all the fluid connections before operating the equipment.
- Check the hoses, tubes, and couplings daily. Replace worn, damaged, or loose parts immediately. Permanently coupled hoses cannot be repaired; replace the entire hose.
- ALWAYS wear eye protection and protective clothing when installing, operating, or servicing this dispensing equipment.
- Do not remove or modify any part of the applicator; this can cause a malfunction and result in serious bodily injury.
- Use extreme caution when cleaning or changing tips. If the tip clogs while applying material, ALWAYS follow the **Pressure Relief Procedure** on page 11, then remove the tip to clean it.
- NEVER wipe off build-up around the tip or air cap until pressure is fully relieved.

! WARNING



FIRE, EXPLOSION, AND ELECTRIC SHOCK HAZARD

Improper grounding, poor air ventilation, open flames, or sparks can cause a hazardous condition and result in fire or explosion and serious injury.

- Ground the equipment and the object being sprayed. The Automatic Dispense Valve is grounded through proper connection of pin E inside the electrical control panel to true earth ground inside the electrical control panel. See **Grounding** on page 9.
- Ground the equipment and the object being sprayed, and all other electrically conductive objects in the dispense area. Proper grounding dissipates static electricity generated in the equipment. See **Grounding** on page 9.
- Do not use this equipment with flammable liquids.
- Keep the dispense area free of debris, including solvent, rags, and gasoline.
- If there is any static sparking or you feel an electric shock while using the equipment, **stop dispensing immediately**. Do not use the equipment until you have identified and corrected the problem.
- Make sure all electrical work is performed by a qualified electrician only.
- Have any checks, installation, or service to electrical equipment performed by a qualified electrician only.
- Make sure all electrical equipment is installed and operated in compliance with applicable codes.
- Make sure power is disconnected when servicing and repairing equipment.
- Before operating the equipment, extinguish all open flames or pilot lights in the dispense area.
- Do not smoke in the dispensing area.
- Keep liquids away from the electrical components.
- Disconnect electrical power at the main switch before servicing the equipment.
- Never exceed maximum wattage of the supply unit.



TOXIC FLUID HAZARD

Hazardous fluids or toxic fumes can cause serious injury or death if splashed in the eyes or on the skin, swallowed, or inhaled.

- Provide fresh air ventilation to avoid the buildup of vapors from the fluid being dispensed.
- Know the specific hazards of the fluid you are using.
- Store hazardous fluid in an approved container. Dispose of hazardous fluid according to all local, state and national guidelines.
- Always wear protective eyewear, gloves, clothing and respirator as recommended by the fluid and solvent manufacturer.
- Avoid exposure to heated material fumes.

Installation

Install the automatic applicator as follows:

- mount the automatic dispense valve
- attach dispense tip, nozzle, or swirl
- connect the air lines
- connect material hose
- connect the electrical cable
- make sure the automatic dispense valve is grounded

Mount the Automatic Dispense Valve

Mount the automatic dispense valve to the mounting bracket on a stationary support or robotic arm (FIG. 1), using two socket head screws (300) and two flat washers (50). Be sure to position the insulation block (280) and insulation tape (290) between the dispense valve and the mounting bracket.

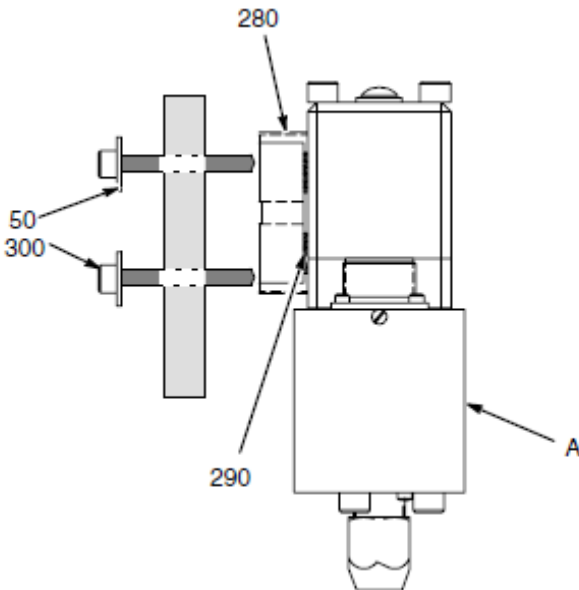

FIG. 1

Attach the Dispense Tip, Nozzle, or Swirl

Attach a dispense tip and a nozzle adapter, or a nozzle adapter alone, to the automatic dispense valve.

Dispense Tip and Nozzle Adapter Attachment

Attach dispense tip (B) to the automatic dispense valve.

1. Select a nozzle adapter (C) and a dispensing tip (B).
2. Install the tip and then use the nozzle adapter (C) to secure the tip to the seat adapter (D).

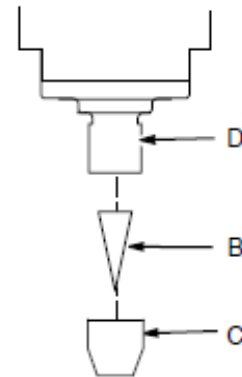

FIG. 2

Nozzle Attachment

Attach a nozzle (C) to the automatic dispense valve.

1. Select a nozzle.
2. Install nozzle adapter (C) on the seat adapter (D).
3. Install nozzle in nozzle adapter (E).

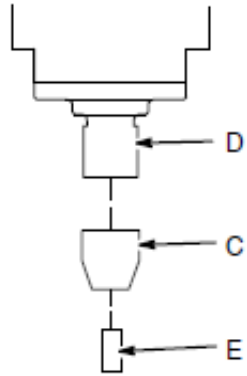

FIG. 3 _____

Swirl Nozzle Attachment

1. Install swirl adapter (C) on seat adapter (D).
2. Install swirl applicator head (E).
3. Install swirl nozzle (F).

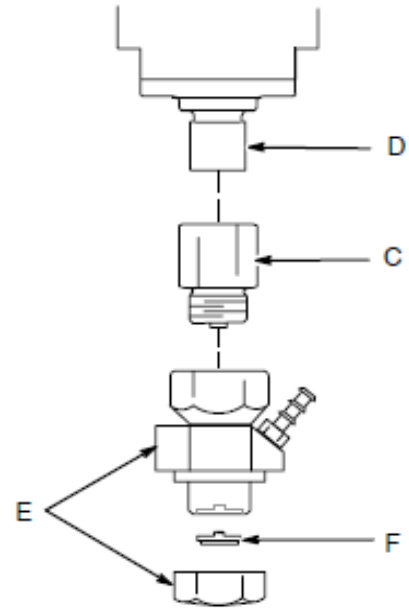

FIG. 4 _____

Connect the Air Lines to the Dispense Valve

⚠ CAUTION

Only use air fittings that are rated at a temperature equal to or higher than the operating temperature of your fluid dispensing system. Lower rated air fittings could melt and cause damage to the automatic dispense valve.

These valves are air to open and air to close with a spring to bias them closed. Use a 4-way exhausting solenoid to operate these valves.

Making sure to connect the appropriate air lines to the appropriate ports (see FIG. 5), securely connect air lines to dispense valve air ports (G).

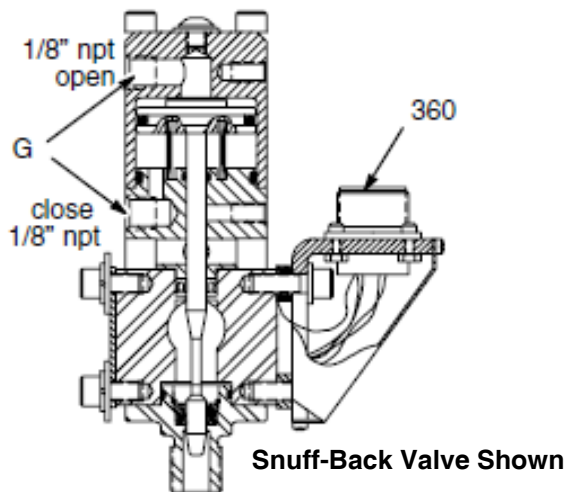

Connect the Material Hose to the Dispense Valve

Securely connect the material hose to the dispense valve material inlet port (A). See FIG. 5.

Connect the Electrical Cable to the Dispense Valve

Connect electrical cable plug from your Therm-O-Flow or Therm-O-Flow Plus hose or control.

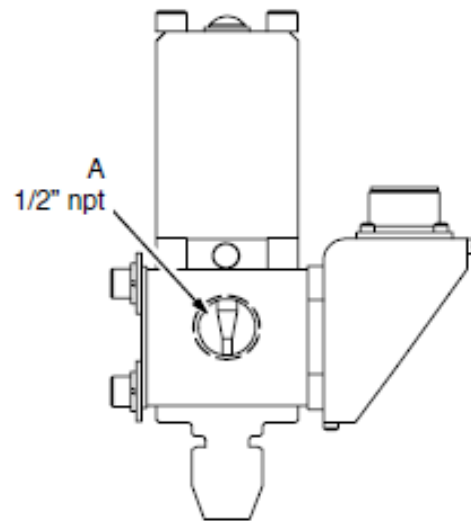

FIG. 5

Grounding

⚠ WARNING



FIRE, EXPLOSION, AND ELECTRIC HAZARD

To reduce the risk of fire, explosion, or electric shock:



- The power source conduit is not an adequate ground for the system. The unit must be grounded to either the building ground or a true earth ground.
- A qualified electrician must complete all grounding and wiring connections and check the resistance.
- Refer to your local code for the requirements for a “true earth ground” in your area.
- Also read and follow the warnings on page 5.

Ground the Automatic Dispense Valve:

1. Connect the connector from a heated hose to the receptacle on the dispense valve.

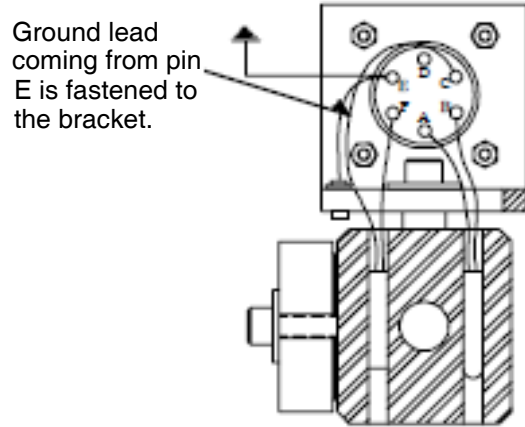

FIG. 6

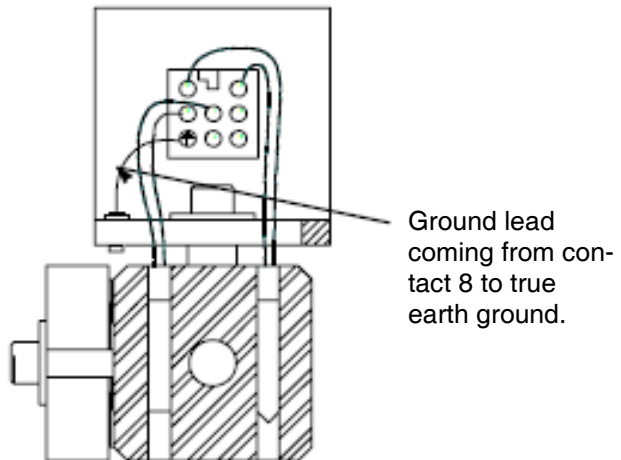

FIG. 7

2. Connect the electrical cable to the electrical control panel.
3. Verify that socket contact E on six pin models (see FIG. 5) or contact eight on eight pin models (see FIG. 7), inside control panel receptacle, is connected to true earth ground.

Troubleshooting

Some solutions require disassembling the automatic dispense valve. Always relieve system pressure before performing these procedures. See PARTS section for the parts that need to be serviced.

⚠ WARNING



To reduce the risk of serious injury whenever you are instructed to relieve pressure, always follow the **Pressure Relief Procedure** (page 11).

Problem	Cause(s)	Solution(s)
Air leaks from automatic dispense valve	Loose air connections	Check air connections.
	Worn o-rings	Replace o-rings (90) and (100) in cylinder base.
	Worn ring	Replace ring (110) in cylinder base.
Material leaks from front of automatic dispense valve	Seal, spacer or retaining ring is worn	Replace rod seal (150), spacer (160), and retaining ring (170).
	Obstruction inside dispense valve	Remove seat adapter (10). Check and replace if necessary, rod seal (150), spacer (160), and retaining ring (170).
	Worn needle	Check and replace needle (140), if necessary. If replacing needle, you must disassemble dispense valve.
	Worn seat (Base seal models)	Check and replace seat (10) if necessary.
Material leaks from automatic dispense valve body	Seal not installed correctly	Check seal (70) and replace if necessary.
	Seal is worn	
Automatic dispense valve does not shut off	Loose air connections	Check air connections.
	Worn needle-seal interface	Check and replace, if necessary, needle (140), rod seal (150), spacer (160), and retaining ring (170). If replacing needle, you must disassemble dispense valve
Automatic dispense valve does not shut off	Worn spring-piston interface	Disassemble dispense valve. Check and replace, if necessary, needle (140), and spring (370).
Automatic dispense valve does not shut off	Spring broken or not installed correctly	Disassemble dispense valve. Check and replace, if necessary, needle (140), and spring (370).
Automatic dispense valve does not heat material	Loose heater wires	Check and reconnect wire connections.
	Loose sensor wires	Check and reconnect wire connections.
	Heater unit failed	Replace heater. See page 17.
	Sensor failed	Replace sensor. See page 17.
	Temperature controller failed	Replace temperature controller.
	No power to heating circuitry	Apply power to heating circuitry.

Service

Pressure Relief Procedure

WARNING



HOT SURFACE AND FLUID HAZARD

The material and equipment will be hot!

To reduce the risk of injury, wear eye protection, gloves and protective clothing when installing, operating, or servicing this dispensing system.



SKIN INJECTION HAZARD

The system pressure must be manually relieved to prevent the system from starting or spraying accidentally. Fluid under high pressure can be injected through the skin and cause serious injury. To reduce the risk of an injury from injection, splashing fluid, or moving parts, follow the **Pressure Relief Procedure** whenever you:

- are instructed to relieve the pressure
- stop spraying/dispensing
- install or clean the nozzle
- check or service any of the system equipment



PRESSURIZED FLUID HAZARD

High pressures can cause serious personal injury. Be sure to **open the dispense valve during system heat-up** to alleviate pressure which might occur in the system due to material expansion.

This procedure describes how to relieve pressure from the automatic dispense valve. See your supply unit or system documentation for instructions on relieving pressure for the entire dispensing system. Use this procedure whenever you shut off the dispense valve and before checking or adjusting any part of the system, to reduce the risk of serious injury.

1. Shut off the material supply.
2. Shut off electrical power to the automatic dispense valve.
3. Close all self bleeding air supply valves for supply unit.
4. Have a container ready to catch the drainage, then bleed off material pressure by actuating the dispense valve.
5. Shut off air supply to valve.

NOTE: *If you suspect that the nozzle or hose is completely clogged, or that the pressure has not been fully relieved after following the steps above, **very slowly** loosen the tip guard, retaining nut or hose end coupling to relieve pressure gradually, then loosen completely. Then clear the tip/nozzle or hose.*

Prepare to Service Automatic Dispense Valve

If the unit is hot, determine whether or not you can service the unit after it has cooled down. Some materials, like polyurethanes, may cure permanently when cooled and exposed to air, preventing you from disassembling the dispense valve. If you are working with such a material, service the unit while the material is at a temperature where the material is soft enough to work with. If the material can be reheated at a later time, you can service the unit after it has cooled, reheating the material as necessary.

Perform this procedure before servicing the automatic dispense valve.

1. Relieve the system pressure.

WARNING

To reduce the risk of serious injury, whenever you are instructed to relieve pressure, always follow the **Pressure Relief Procedure** (page 11).

2. Make sure material flow has been shut off.
3. Make sure system air has been shut off.
4. Remove power from the automatic dispense valve.

WARNING



HOT SURFACE AND FLUID HAZARD
The material and equipment may be hot!
To reduce the risk of injury, wear eye protection, gloves and protective clothing when servicing this dispensing system component.

5. If the material in the dispense valve can be reheated, wait for the dispense valve to cool thoroughly before servicing it.

If the material in the dispense valve cures permanently when cooled and/or exposed to air, service the unit while the material is at a temperature where the material is soft enough to work with.

Service the Automatic Dispense Valve

Some dispense valve seals and o-rings can be replaced while the dispense valve is still mounted. However, to replace the needle, you must remove the automatic dispense valve from the mounting bracket and disassemble it.

Prior to installation, lubricate all seals and o-rings with 115982 Graco thermal lubricant (3 oz. cartridge) or an equivalent lubricant. Check with the material supplier for a compatible lubricant.

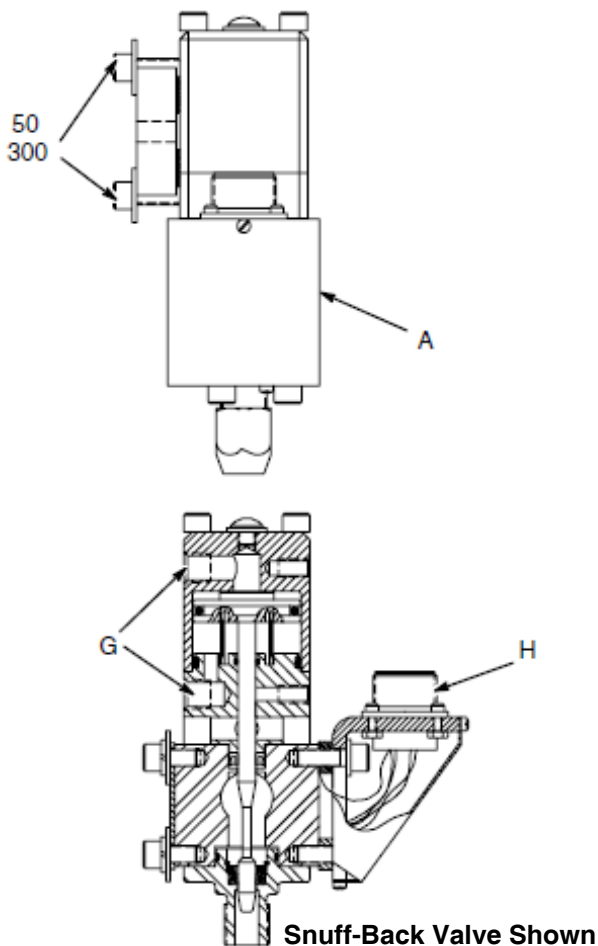

FIG. 8

Disconnect the Automatic Dispense Valve from the Mounting Bracket

Remove the automatic dispense valve from its mounting bracket.

1. Perform the procedures in Prepare to **Service the Automatic Dispense Valve** on page 13.

! WARNING



HOT SURFACE AND FLUID HAZARD
The material and equipment may be hot!
 To reduce the risk of injury, wear eye protection, gloves and protective clothing when servicing this dispensing system component.

2. Disconnect the cable plug from receptacle on dispense valve (H). See FIG. 8 on page 13.
3. Disconnect air lines from dispense valve air ports (G).
4. Disconnect material hose from material inlet port (A).
5. Separate the dispense valve body from the temperature conditioning manifold if used:

Reconnect the Automatic Dispense Valve to the Mounting Bracket

Reconnect the automatic dispense valve to its mounting bracket. See FIG. 8.

1. Reconnect air lines to dispense valve air ports (G).
2. Reconnect the electrical cable plug to the receptacle (H).
3. Reconnect the material hose to the dispense valve material inlet port (A).

Disassemble the Automatic Dispense Valve

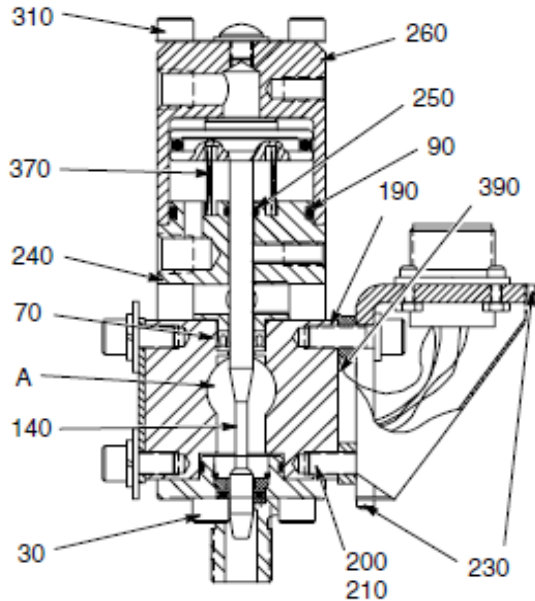

Snuff-Back Valve Shown

FIG. 9

To disassemble the automatic dispense valve:

1. **Relieve automatic dispense valve pressure.**

⚠ WARNING

To reduce the risk of serious injury, whenever you are instructed to relieve pressure, always follow the **Pressure Relief Procedure** (page 11).

2. Make sure you have removed the dispense valve from its mounting.
3. Remove the cable plug from the automatic dispense valve.
 - a. Remove the two screws (230) from the connector cover. Then remove the connector cover.
 - b. Remove the two socket head screws [FIG. 9, Item (200)], two washers (210). The heater cartridge (270) and sensor (320) will come out of the dispense valve body (FIG. 15).

4. Remove the four socket head screws (310) and pull cylinder cap (260) and cylinder base (240) from the dispense valve body (190). The needle and piston remain with the cap and base.
5. Remove cap from base.
6. Remove needle from either the cap or the base (depending on which piece it went with). When the needle is separated from the base, the closure spring (370) falls out.
7. Using an o-ring pick, remove dispense valve body seal (70).
8. Disassemble adapter assembly (FIG. 10):
 - a. Unscrew nozzle adapter (C).
 - b. Remove three socket head screws (30 in FIG. 9).
 - c. Remove seat adapter (10). Contains seat on base seal valves.
 - d. Remove retaining ring (170) from adapter seat (FIG. 10). Not on base seal guns.
 - e. Remove seal (150) and spacer (160) from adapter seat (FIG. 10). not on base seal guns.
 - f. Remove o-ring (20) from adapter seat.

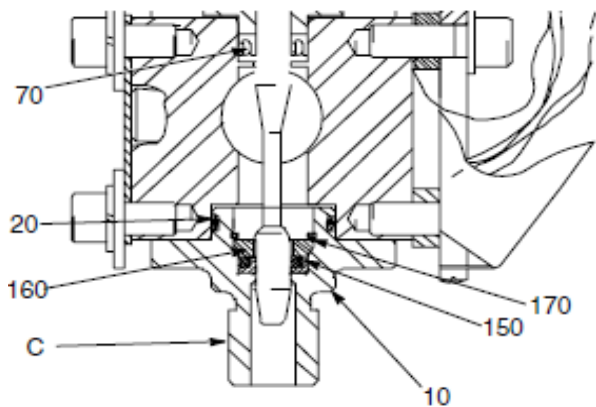

Snuff-Back Valve Shown

FIG. 10

Reassemble the Automatic Dispense Valve

Prior to installation, lubricate all seals and o-rings with 115982 Graco high temperature grease (3 oz. cartridge), or an equivalent lubricant. Check with the material supplier for a compatible lubricant.

To reassemble the automatic dispense valve:

1. Make sure all parts are free of solid material residue.
2. Reassemble adapter assembly (FIG. 10):
 - a. Lubricate and replace o-ring (20).
 - b. Lubricate and replace seal (150) and spacer (160). Make sure the seal energizer faces toward the material pressure.
 - c. Replace retaining ring (170).
 - d. Replace seat retainer (10).
 - e. Insert and tighten three socket head screws (30 in FIG. 9).
 - f. Screw on nozzle adapter (C).
3. Lubricate then replace dispense valve body seal (70). Make sure the seal energizer faces toward the material pressure.
4. Reassemble cap and base (FIG. 11):
 - a. Lubricate o-ring (100) and ring (110).
 - b. Insert o-ring (100) into needle piston (140) groove.
 - c. Slide ring (110) on top of o-ring (100).
 - d. Lubricate, then replace o-rings (90) and (250). Insert spring on base seal models (FIG. 12).
 - e. Insert needle assembly into cylinder cap (260).
 - f. Place spring (370) over shaft of needle/piston. Seat spring in groove on piston face on snuff-back models (FIG. 11).

- g. Slide base (240), over the needle, into the cylinder cap (260). Seat spring (370) in groove on base.

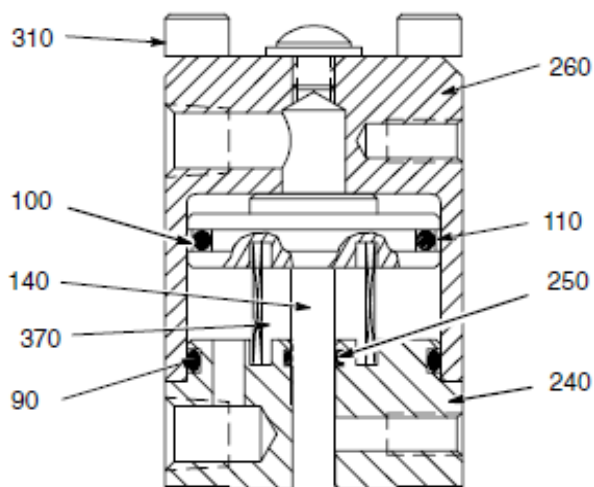

Snuff-Back Valve Shown

FIG. 11

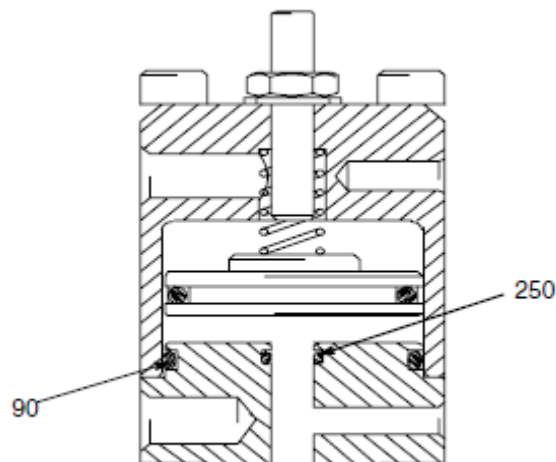

Base Seal Valves

FIG. 12

5. Reconnect the cable receptacle to the automatic dispense valve. See FIG. 13.
 - a. Re-insert heater cartridge and sensor into their appropriate holes.
 - b. Ensure the ground wire (380) is connected to the bracket (330).

- c. Connect the receptacle to the dispense valve body. Then secure it with the two socket head screws (200) and washers (210).
- d. Reattach the receptacle cover. Then secure it with the two screws (230).

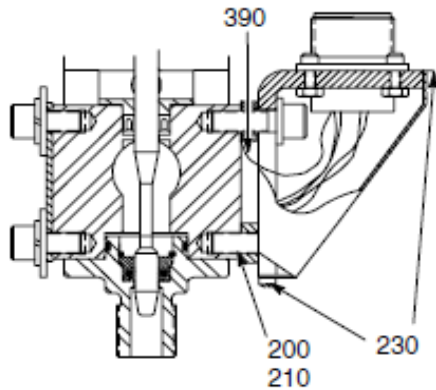

FIG. 13

Replace the Heater Unit or Sensor

You can replace the automatic dispense valve heater unit or sensor without removing the automatic dispense valve from its mounting bracket. You only have to disconnect the cable connector from the automatic dispense valve.

This procedure requires:

- soldering iron
- solder
- shrink wrap
- wire cutters
- heat sink compound, Graco part number C07664 or equivalent. Check with the material supplier for a compatible compound.

1. Perform the procedures in **Prepare to Service Automatic Dispense Valve** on page 12.
2. Remove the cable receptacle from the automatic dispense valve.
 - a. Remove the two screws from the connector cover [FIG. 9, Item (230)] and remove the receptacle cover.
 - b. Remove the two socket head screws [FIG. 14, Item (200)], two washers (210). The heater cartridge (270) and sensor (320) will come out of the dispense valve body.

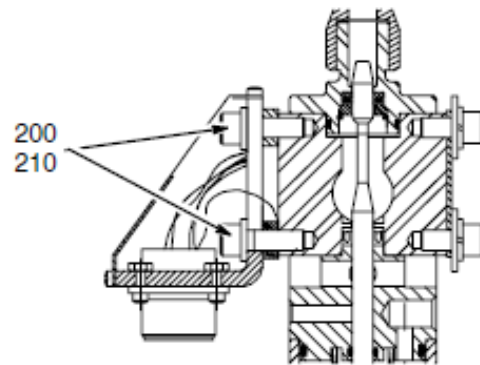

FIG. 14

3. Remove old heater cartridge or sensor.
 - a. Locate the leads to the part you are replacing.
 - b. Remove the shrink wrap from the leads.
 - c. Unsolder the leads from the connector. Cut the leads on 8 pin models, leaving enough to strip and solder the leads.
4. Install new heater unit or sensor:

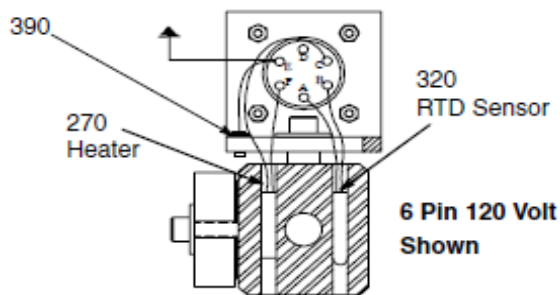

FIG. 15

- a. Install the shrink wrap over the leads.
- b. Solder the leads to the appropriate connector (FIG. 15) for 6 pin connector. For Therm-O-Flow 8 pin assemblies, removal and replacement of the heaters and RTD require a pin extraction tool, new pins, and a pin crimping tool. These tools meet spec MIL-C-22520 [Ref. Daniels AF8 (crimp tool) or equivalent, available at local electrical supply warehouse.
- c. Coat heater or sensor with heat sink compound.
- d. Gently slide new heater or sensor into appropriate hole.
- e. Either shrink the shrink wrap, or use electrical tape to electrically insulate the connection between the leads and connector pins.

5. Reconnect the dispense valve to the receptacle (FIG. 14):

- a. Reattach the receptacle base to the dispense valve body and secure it with the two socket head screws [FIG. 14, Items (200) and washer (210)].
- b. Reattach the receptacle cover to the Amphenol connector base and secure the cover with the screws.

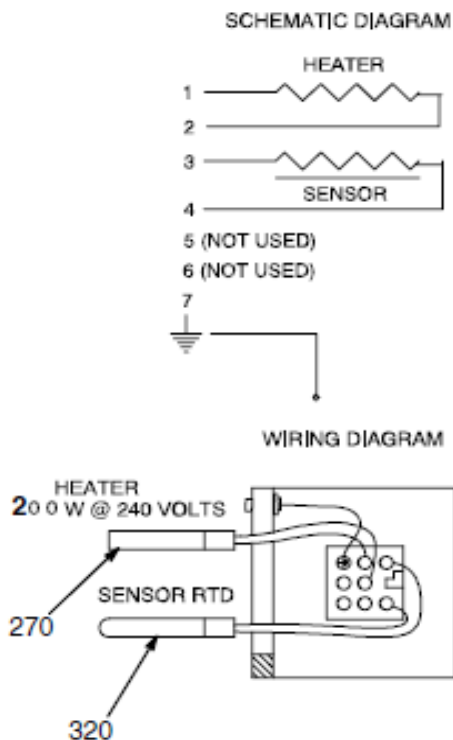

FIG. 16

Inspection Frequency

Automatic Dispense Valve

Inspect automatic dispense valve at least once every two weeks for leakage or other visible damage.

Check specifically for:

- material leaks
- air leaks

Hoses/Tubes

Inspect hoses/tubes at least once every two weeks for leakage or other visible damage.

- material hose
- air hoses

Heater

Every two weeks, check heater for proper resistance. Resistance should be approximately 96 ohms for the 120 volt valves or 288 ohms (+30/–40) for the 240 volt valves. Replace heater if necessary.

Also inspect heater when performing regular maintenance procedures.

Sensor

Every two weeks, check sensor resistance. Resistance should be 108 ohms at 21° C (70° F). Replace sensor if necessary.

Also inspect sensor when performing regular maintenance procedures.

Parts

Model 194485, Warm (275°F/135°C max) Automatic Dispense Valve with Snuff Back

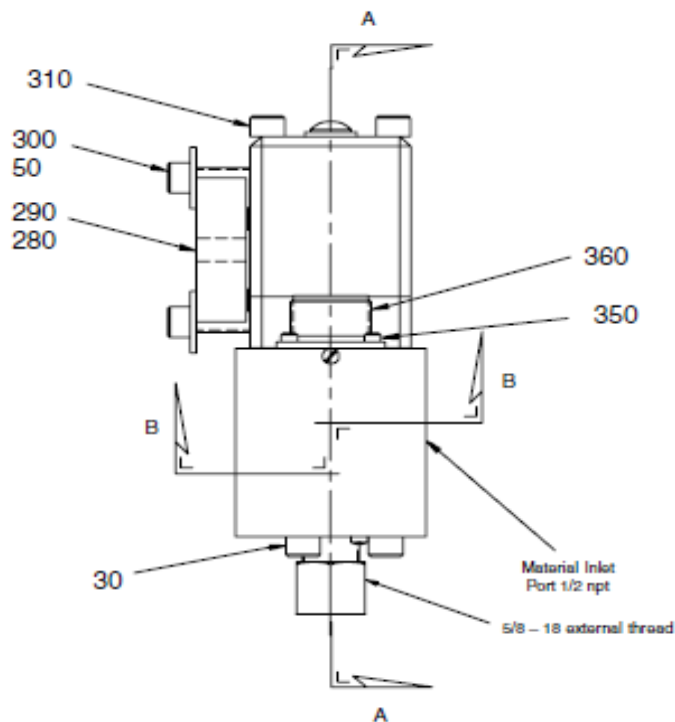
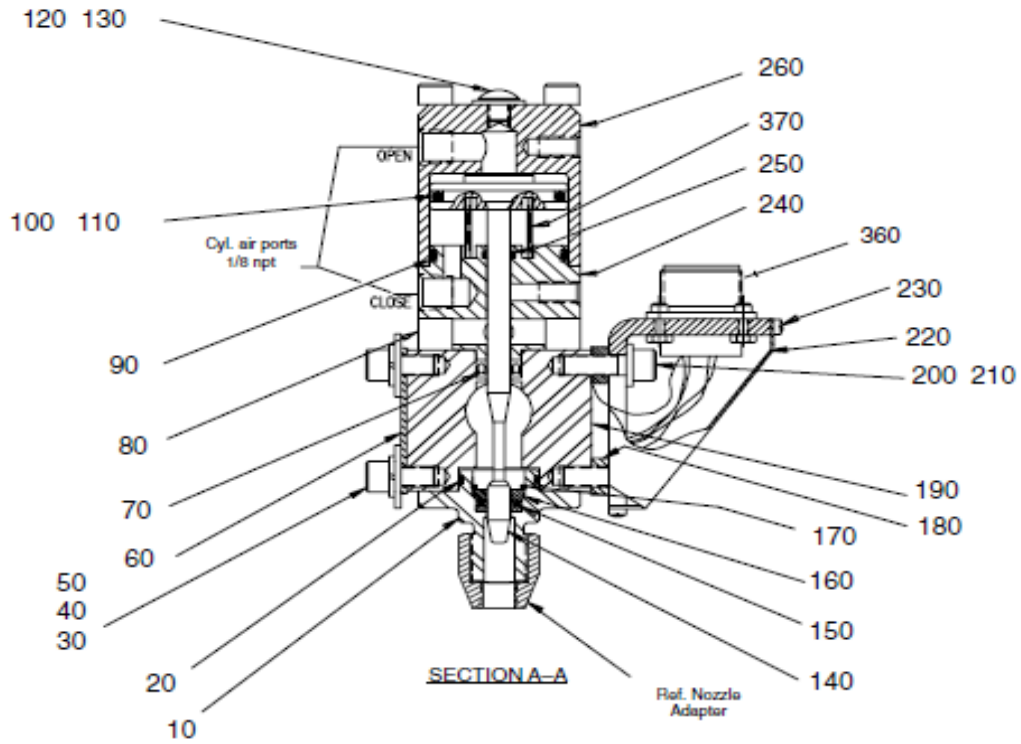

Model 194485, Warm (275°F/135°C max) Automatic Dispense Valve with Snuff Back

Ref No.	Part No.	Description	Qty.	Ref No.	Part No.	Description	Qty.
				220	C34040	COVER	1
10	617479	ADAPTER, seat	1	230	C19269	SCREW, fill. hd. machine, #4 - 40 x 0.25	2
20*	16D530	O-RING	1	240	617537	BASE, cylinder	1
30	C19800	SCREW, soc. hd. cap, 1/4" - 20 x 0.5	5	250*	103337	O-RING, -010 fluoroelastomer	1
40	100016	WASHER, lock, 1/4"	2	260	C34028	CAP, cylinder	1
50	111591	WASHER, flat, 1/4"	4	270✓	C31034	HEATER, cartridge 120V, 150W	1
60	C34044	PLATE, blank-off	1	280	C32099	BLOCK, mounting	1
70*	551190	SEAL, Polymite	1	290	C33037	TAPE, fiberglass, 0.5" wide (229 mm)	9"
80	C34030	SPACER	4	300	C19810	SCREW, soc. hd. cap, 1/4" - 20 x 1	2
90*	113944	O-RING, -125 flouroelastomer	1	310	104594	SCREW, soc. hd. cap, 1/4" - 20 x 3.25	4
100*	103649	O-RING, -123 flouroelastomer	1	320✓	C32255	SENSOR, RTD	1
110*	C32088	RING	1	330	C34043	BRACKET	1
120	617495	SCREW, button head, 1/4" - 20 x 0.31	1	340	102794	NUT, hex, #4 - 40	4
130*	C20521	SEAL, thread	1	350	C19270	SCREW, fill. hd. machine, #4 - 40 x 0.38	4
140✓	918471	NEEDLE, piston	1	360	C07329	CONNECTOR, 6 pin	1
150*	C54172	SEAL, rod, 0.25 x 0.50 x 0.25	1	370*	617536	SPRING	1
160	617480	SPACER	1	380	065345	WIRE, high temp. (127 mm)	5"
170*	C20406	RING, retaining, for 0.56 I.D.	1	390	101674	TERMINAL, ring	1
180	C34045	SPACER	2	400	C07664	COMPOUND, heat sink	A/R
190	194527	BODY, gun	1	460	112144	SCREW	1
200	112166	SCREW, soc. hd. cap, 1/4" - 20 x 0.75	2	510	157021	WASHER, lock	1
210	C19197	WASHER, flat, 3/16	2				

* These parts are included in Repair Kit 194486, which may be purchased separately.
 ✓ Keep these spare parts on hand to reduce down time.

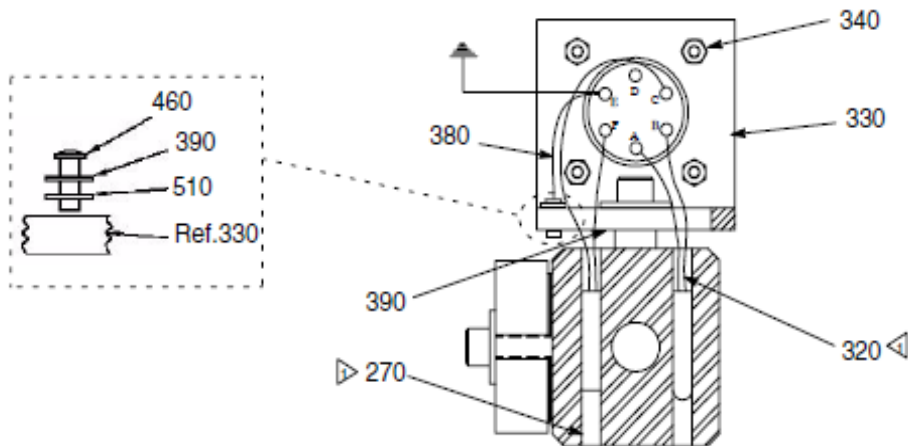

SECTION B-B (Enlarged to show detail)

Notes
 ▷ Coat with heat sink compound (400) before installing.

Model 918483, Therm-O-Flow Automatic Dispense Valve with Snuff Back

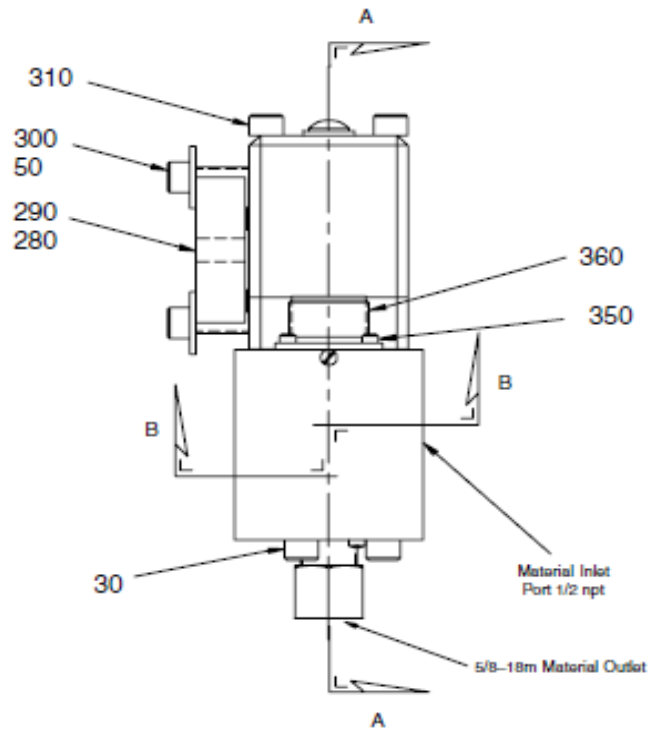
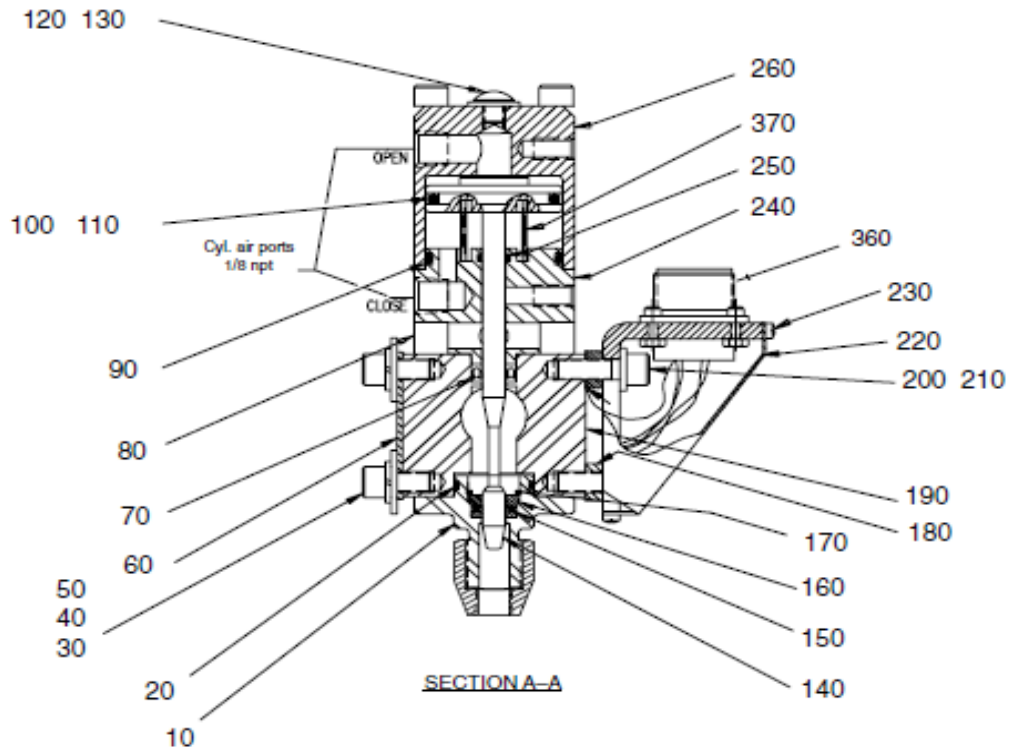

Model 918483, Therm-O-Flow Automatic Dispense Valve with Snuff Back

Ref No.	Part No.	Description	Qty.	Ref No.	Part No.	Description	Qty.
				230	C19269	SCREW, fill. hd. machine, #4 - 40 x 0.25	2
10	617479	ADAPTER, seat	1	240	617603	BASE, cylinder	1
20*	16D530	O-RING	1	250*	103337	O-RING, -010 fluoroelastomer	1
30	C19800	SCREW, soc. hd. cap, 1/4" - 20 x 0.5	5	260	C34028	CAP, cylinder	1
40	100016	WASHER, lock, 1/4"	2	270✓	C31034	HEATER, cartridge 120V, 150W	1
50	110755	WASHER, flat, 1/4"	4	280	C32099	BLOCK, mounting	1
60	C34044	PLATE, blank-off	1	290	C33037	TAPE, fiberglass, 0.5" wide (229 mm)	9"
70*	617604	SEAL	1	300	C19810	SCREW, soc. hd. cap, 1/4" - 20 x 1	2
80	C34030	SPACER	4	310	104594	SCREW, soc. hd. cap, 1/4" - 20 x 3.25	4
90*	113944	O-RING, -125 flouroelastomer	1	320✓	C32255	SENSOR, RTD	1
100*	103649	O-RING, -123 flouroelastomer	1	330	C34043	BRACKET	1
110*	C32088	RING	1	340	102794	NUT, hex, #4 - 40	4
120	617495	SCREW, button head, 1/4" - 20 x 0.31	1	350	C19270	SCREW, fill. hd. machine, #4 - 40 x 0.38	4
130*	C20521	SEAL, thread	1	360	C07329	CONNECTOR, 6 pin	1
140✓	918471	NEEDLE, piston	1	370*	617536	SPRING	1
150*	617491	SEAL, rod hi temp, 0.25 x 0.50 x 0.25	1	380	065345	WIRE, high temp. (127 mm)	5"
160	617480	SPACER	1	390	101674	TERMINAL, ring	1
170*	C20406	RING, retaining, for 0.56 I.D.	1	400	C07664	COMPOUND, heat sink	A/R
180	C34045	SPACER	2	460	112144	SCREW	1
190	617605	BODY	1	510	157021	WASHER, lock	1
200	112166	SCREW, soc. hd. cap, 1/4" - 20 x 0.75	2				
210	C19197	WASHER, flat, 3/16	2				

* These parts are included in Repair Kit 918520, which may be purchased separately.

✓ Keep these spare parts on hand to reduce down time.

220	C34040	COVER	1
-----	--------	-------	---

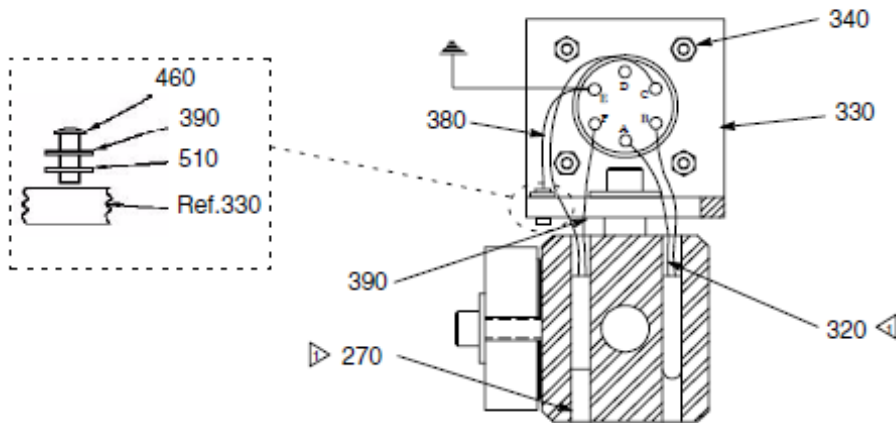

SECTION B-B (Enlarged to show detail)

Notes

- ▶ Coat with heat sink compound (400) before installing.

Model 918512, Ambient Therm-O-Flow Automatic Dispense Valve with Snuff Back

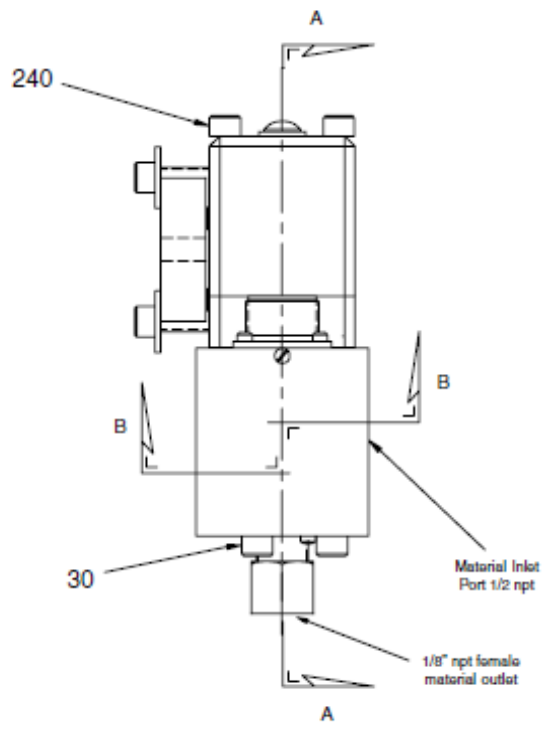
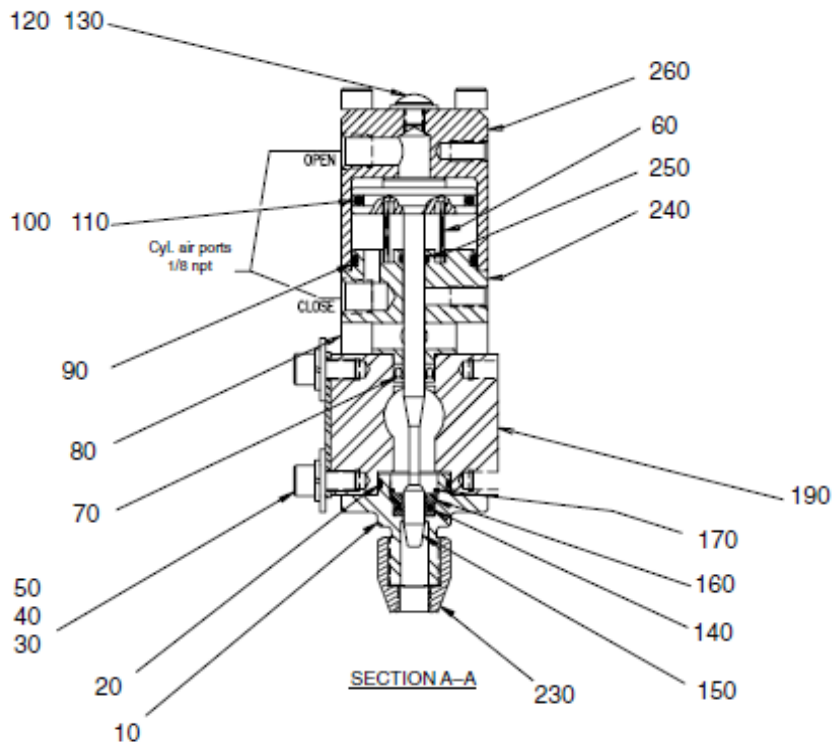

Model 918512, Therm-O-Flow Automatic Dispense Valve with Snuff Back

Ref No.	Part No.	Description	Qty.	Ref No.	Part No.	Description	Qty.
10	617479	ADAPTER, seat	1	130	C20521	SEAL, thread	1
20	16D530	O-RING	1	140	617491	SEAL, outlet	1
30	C19800	SCREW, soc. hd. cap, 1/4" - 20 x 0.5	5	150	918471	NEEDLE assembly	1
40	100016	WASHER, lock, 1/4"	2	160	617480	SPACER	1
50	110755	WASHER, flat, 1/4"	4	170	111209	RING, retaining, for 0.56 I.D.	1
60	617536	SPRING	1	190	194527	BODY	1
70	C34032	SEAL	1	200	617537	BASE, cylinder	1
80	C34030	SPACER	4	210	103337	O-RING, -010 fluoroelastomer	1
90	113944	O-RING, -123 fluoroelastomer	1	220	C34028	CAP, cylinder	1
100	103649	O-RING	1	230	C32089	RETAINER	1
110	C32088	O-RING	1	240	104594	SCREW, cap	4
120	112925	SCREW, button head, 1/4" - 20 x 0.31	1				

✓ *Keep these spare parts on hand to reduce down time.*

Model 918639, Therm-O-Flow Automatic Dispense Valve with Snuff Back

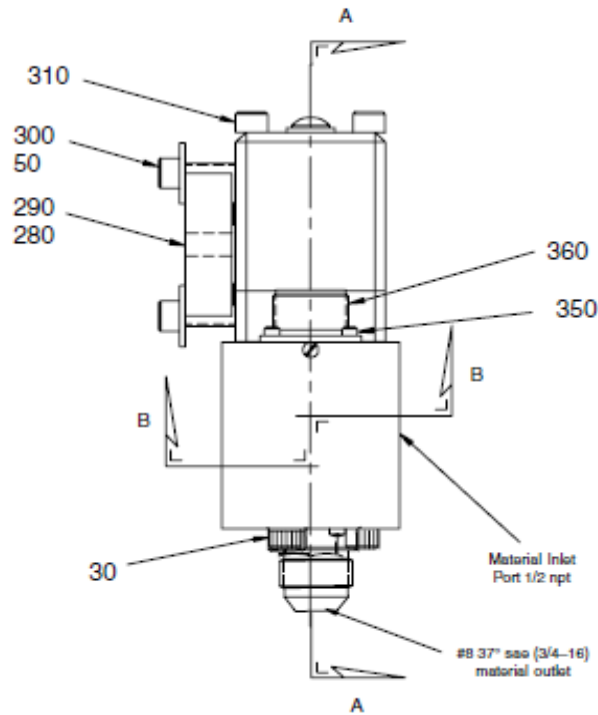
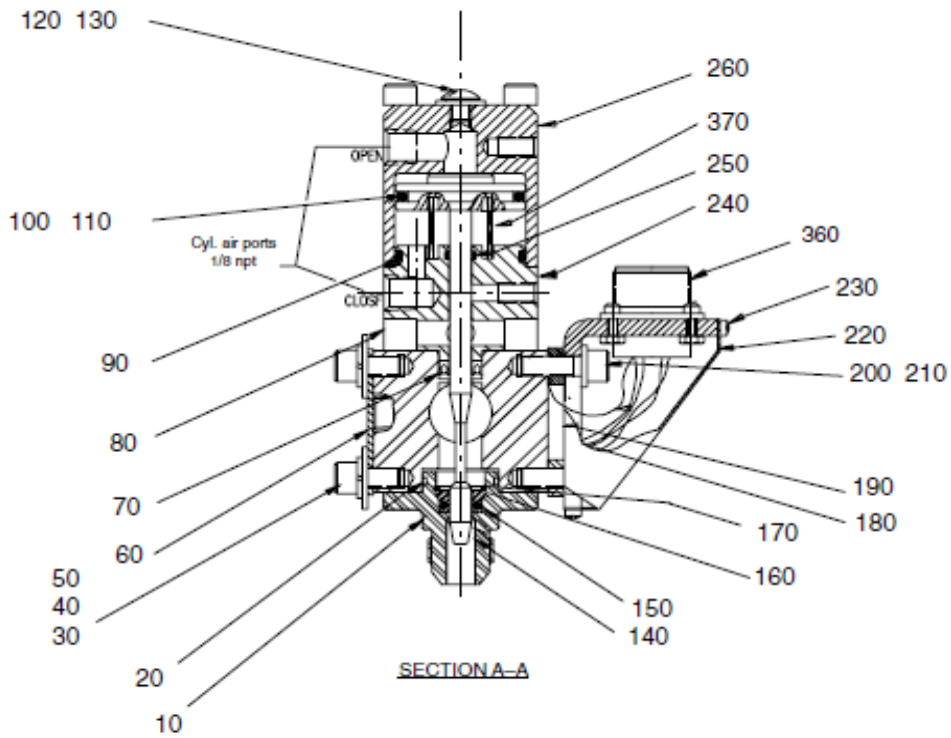

Model 918639, Therm-O-Flow Automatic Dispense Valve with Snuff Back

Ref No.	Part No.	Description	Qty.	Ref No.	Part No.	Description	Qty.
10	617690	ADAPTER, nozzle/valve	1	240	617603	BASE, cylinder	1
20*	16D530	O-RING	1	250*	103337	O-RING, -010 fluoroelastomer	1
30	C19800	SCREW, soc. hd. cap, 1/4" - 20 x 0.5	5	260	C34028	CAP, cylinder	1
40	100016	WASHER, lock, 1/4"	2	270✓	C31034	HEATER, cartridge 120V, 150W	1
50	110755	WASHER, flat, 1/4"	4	280	C32099	BLOCK, mounting	1
60	C34044	PLATE, blank-off	1	290	C33037	TAPE, fiberglass, 0.5" wide (229 mm)	9"
70*	617604	SEAL	1	300	C19810	SCREW, soc. hd. cap, 1/4" - 20 x 1	2
80	C34030	SPACER	4	310	104594	SCREW, soc. hd. cap, 1/4" - 20 x 3.25	4
90*	113944	O-RING, -125 fluoroelastomer	1	320✓	C32255	SENSOR, RTD	1
100*	103649	O-RING, -123 fluoroelastomer	1	330	C34043	BRACKET	1
110*	C32088	RING	1	340	102794	NUT, hex, #4 - 40	4
120	617495	SCREW, button head, 1/4" - 20 x 0.31	1	350	C19270	SCREW, fill. hd. machine, #4 - 40 x 0.38	4
130*	C20521	SEAL, thread	1	360	C07329	CONNECTOR, 6 pin	1
140✓	918471	NEEDLE, piston	1	370*	617536	SPRING	1
150*	617491	SEAL, rod hi temp, 0.25 x 0.50 x 0.25	1	380	065345	WIRE, high temp. (127 mm)	5"
160	617480	SPACER	1	390	101674	TERMINAL, ring	1
170*	C20406	RING, retaining, for 0.56 I.D.	1	400	C07664	COMPOUND, heat sink	A/R
180	C34045	SPACER	2	460	112144	SCREW	1
190	617605	BODY	1	510	157021	WASHER, lock	1
200	112166	SCREW, soc. hd. cap, 1/4" - 20 x 0.75	2				
210	C19197	WASHER, flat, 3/16	2				
220	C34040	COVER	1				
230	C19269	SCREW, fill. hd. machine, #4 - 40 x 0.25	2				

* These parts are included in Repair Kit 918520, which may be purchased separately.
 ✓ Keep these spare parts on hand to reduce down time.

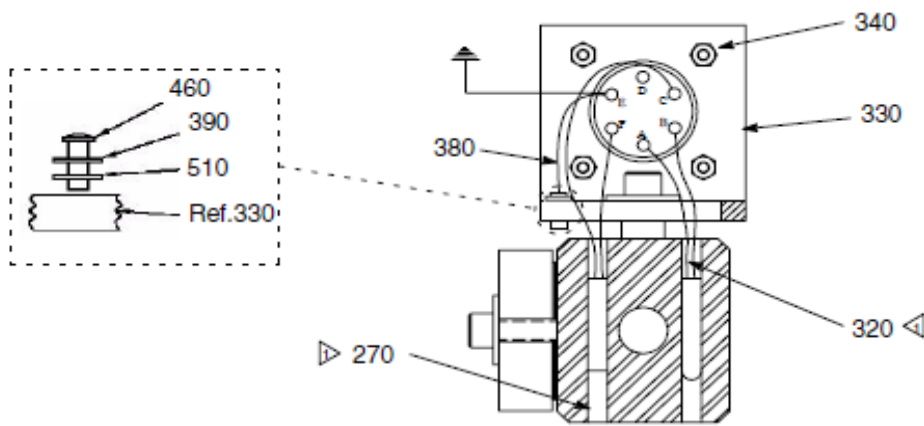

SECTION B-B (Enlarged to show detail)

Notes

- ▶ Coat with heat sink compound (400) before installing.

Model 243694, Therm-O-Flow Automatic Dispense Valve

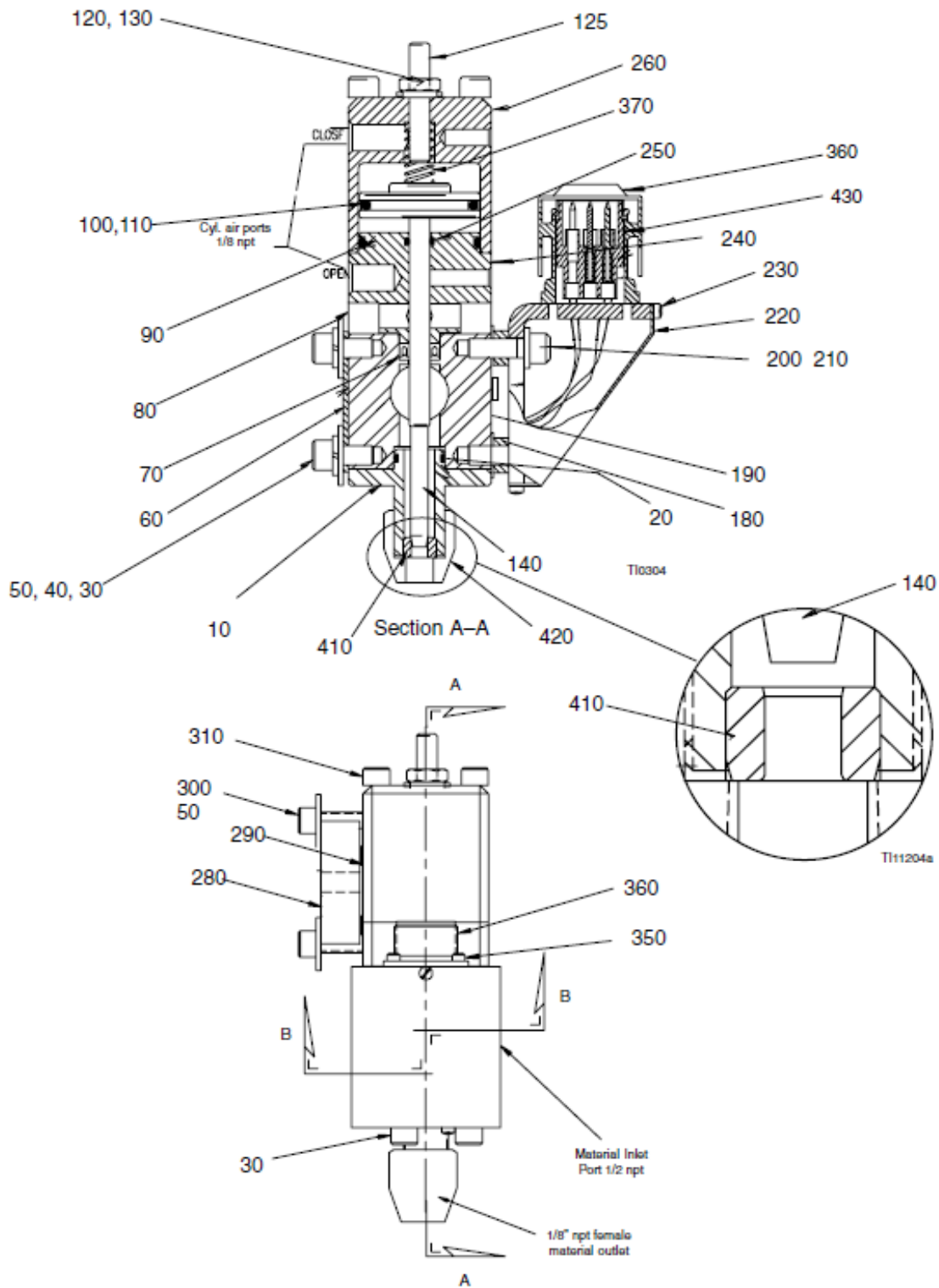

Model 243694, Therm-O-Flow Automatic Dispense Valve

Ref No.	Part No.	Description	Qty.	Ref No.	Part No.	Description	Qty.
10	C32083	ADAPTER, seat	1	270✓	116011	HEATER, cartridge 230V, 200W	1
20*	103610	O-RING, -018 flouroelastomer	1	280	C32099	BLOCK, mounting	1
30	C19800	SCREW, soc. hd. cap, 1/4" - 20 x 0.5	5	290	C33037	TAPE, fiberglass, 0.5" wide (229 mm)	9"
40	100016	WASHER, lock, 1/4"	2	300	C19810	SCREW, soc. hd. cap, 1/4" - 20 x 1	2
50	110755	WASHER, flat, 1/4"	4	310	104594	SCREW, soc. hd. cap, 1/4" - 20 x 3.25	4
60	C34044	PLATE, blank-off	1	320✓	C32255	SENSOR, RTD	1
70*	C34032	SEAL, graphite/PTFE	1	330	C34043	BRACKET	1
80	C34030	SPACER	4	350	C19949	SCREW, pan hd. machine, #4 - 40 x 0.5	2
90*	113944	O-RING, -125 flouroelastomer	1	360	115861	HOUSING, 8 pin	1
100*	103649	O-RING, -123 flouroelastomer	1	370	C34041	SPRING	1
110*	C32088	RING	1	380	065345	WIRE, high temp. (127 mm)	5"
120	112248	NUT, hex	1	390	101674	TERMINAL, ring	1
125	C19359	SCREW, set	1	410	C32090	SEAT	1
130*	C20521	SEAL, thread	1	420	C32089	NUT, retainer	1
140✓	C32082	NEEDLE, assembly	1	430	115860	INSERT, male	1
180	C34045	SPACER	2	440	115862	CONNECTOR, male, crimp	1
190	C32097	BODY	1	460	112144	SCREW, PH 8-32 x 1/4	1
200	112166	SCREW, soc. hd. cap, 1/4" - 20 x 0.75	2	510	157021	WASHER, lock	1
210	C19197	WASHER, flat, 3/16	2	520	116640	CONNECTOR	4
220	C34040	COVER	1				
230	C19269	SCREW, fill. hd. machine, #4 - 40 x 0.25	2				
240	C32085	BASE, cylinder	1				
250*	103337	O-RING, -010 fluoroelastomer	1				
260	C34028	CAP, cylinder	1				

* These parts are included in Repair Kit C27342, which may be purchased separately.

✓ Keep these spare parts on hand to reduce down time.

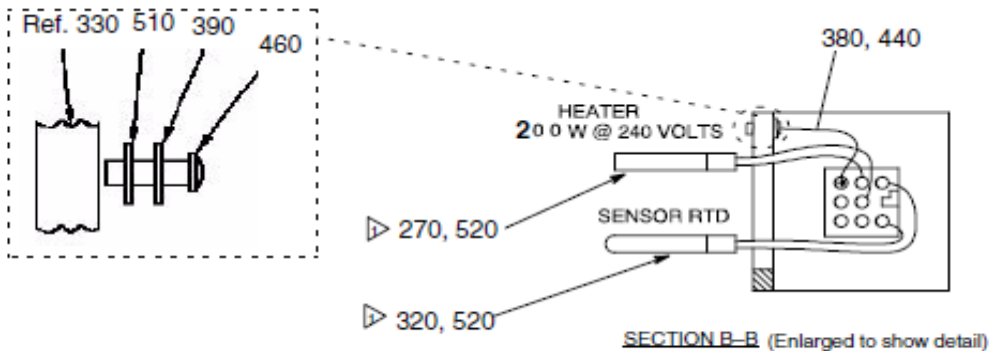

Notes

- ▶ Coat with heat sink compound (400) before installing.

Model 297266, Automatic Hot Melt Swirl Dispense Valve

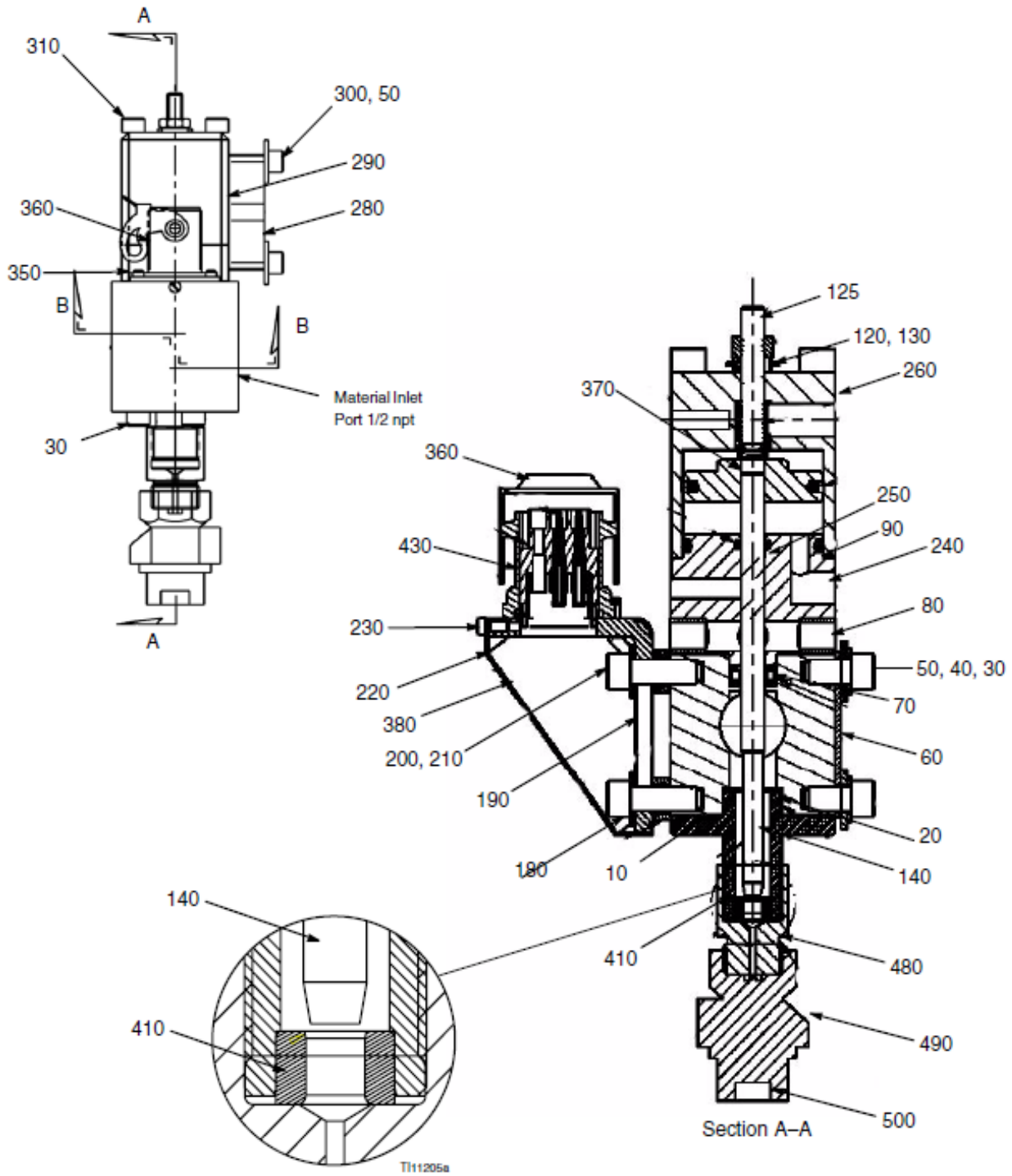

Model 297266, Automatic Hot Melt Swirl Dispense Valve

Ref No.	Part No.	Description	Qty.	Ref No.	Part No.	Description	Qty.
10	C32083	ADAPTER, seat	1	280	C32099	BLOCK, mounting	1
20*	103610	O-RING, -018 flouroelastomer	1	290	C33037	TAPE, fiberglass, 0.5" wide (229 mm)	9"
30	C19800	SCREW, soc. hd. cap, 1/4" - 20 x 0.5	5	300	C19810	SCREW, soc. hd. cap, 1/4" - 20 x 1	2
40	100016	WASHER, lock, 1/4"	2	310	104594	SCREW, soc. hd. cap, 1/4" - 20 x 3.25	4
50	110755	WASHER, flat, 1/4"	4	320✓	C32255	SENSOR, RTD	1
60	C34044	PLATE, blank-off	1	330	C34043	BRACKET	1
70*	C34032	SEAL, graphite/PTFE	1	350	C19949	SCREW, pan hd. machine, #4 - 40 x 0.5	2
80	C34030	SPACER	4	360	115861	HOUSING, 8 pin	1
90*	113944	O-RING, -125 flouroelastomer	1	370	C34041	SPRING	1
100*	103649	O-RING, -123 flouroelastomer	1	380	065345	WIRE, high temp. (127 mm)	5"
110*	C32088	RING	1	390	101674	TERMINAL, ring	1
120	112248	NUT, hex	1	410	C32090	SEAT	1
125	C19359	SCREW, set	1	430	115860	INSERT, male	1
130*	C20521	SEAL, thread	1	440	115862	CONNECTOR, male, crimp	1
140✓	C32082	NEEDLE, assembly	1	460	112144	SCREW, PH 8-32 x 1/4	1
180	C34045	SPACER	2	480	15H098	ADAPTER, swirl	1
190	C32097	BODY	1	490	118072	HEAD, applicator, swirl	1
200	112166	SCREW, soc. hd. cap, 1/4" - 20 x 0.75	2	500	117950	NOZZLE, swirl, 0.30	1
210	C19197	WASHER, flat, 3/16	2	510	157021	WASHER, lock	1
220	C34040	COVER	1	520	116640	CONNECTOR	4
230	C19269	SCREW, fill. hd. machine, #4 - 40 x 0.25	2				
240	C32085	BASE, cylinder	1				
250*	103337	O-RING, -010 fluoroelastomer	1				
260	C34028	CAP, cylinder	1				
270✓	116011	HEATER, cartridge 230V, 200W	1				

* These parts are included in Repair Kit C27342, which may be purchased separately.

✓ Keep these spare parts on hand to reduce down time.

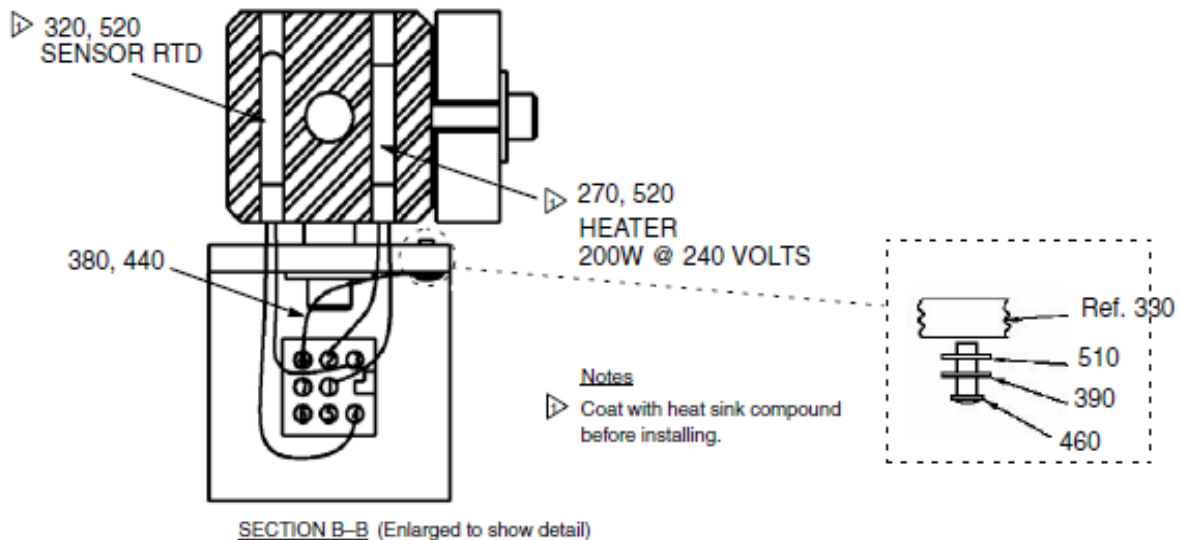

Model 243695, Therm-O-Flow Automatic Dispense Valve

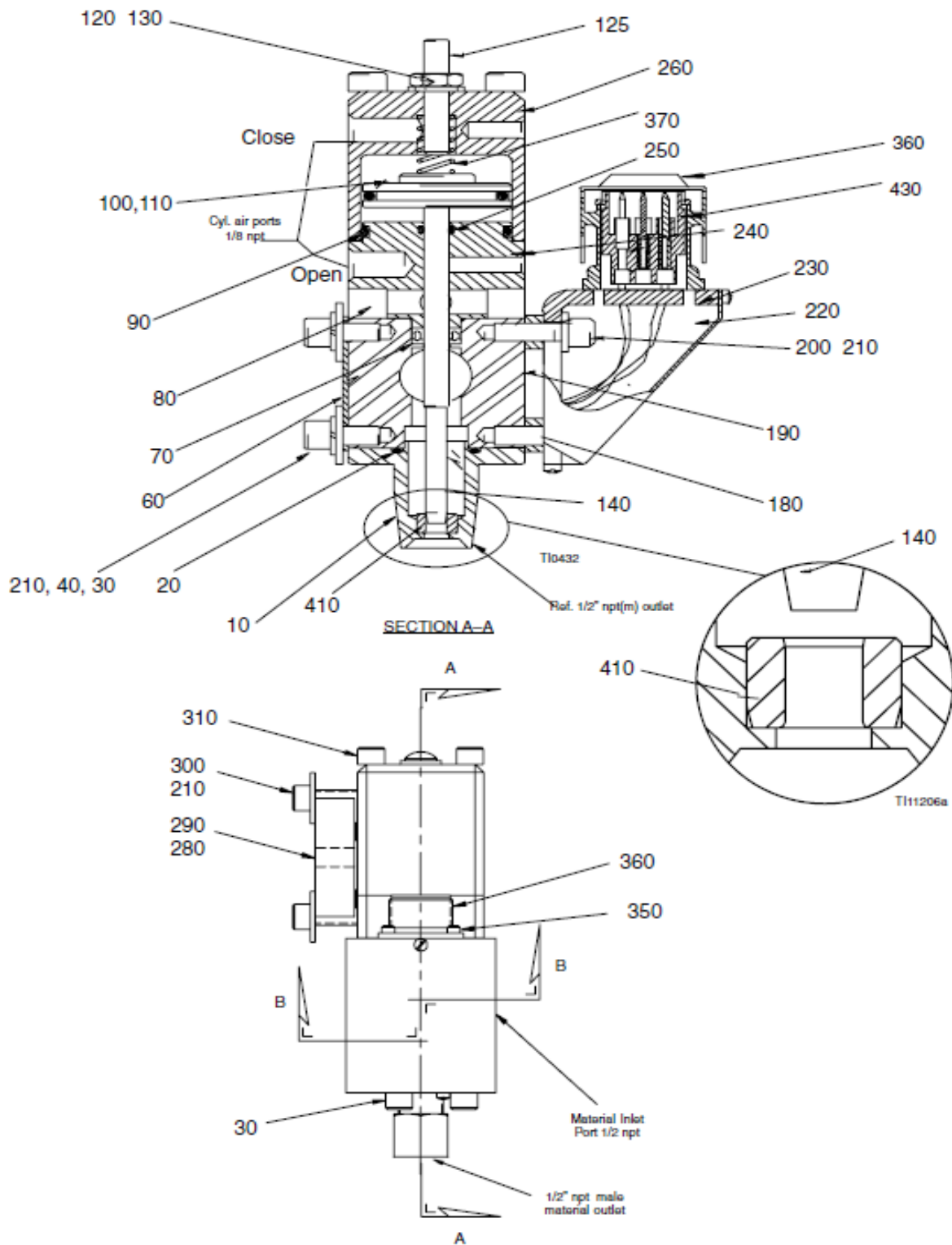

Model 243695, Therm-O-Flow Automatic Dispense Valve

Ref No.	Part No.	Description	Qty.	Ref No.	Part No.	Description	Qty.
10	C51762	ADAPTER, seat	1	260	C34028	CAP, cylinder	1
20*	273083	O-RING	1	270✓	116011	HEATER, cartridge 230V, 200W	1
30	C19800	SCREW, soc. hd. cap, 1/4" - 20 x 0.5	5	280	C32099	BLOCK, mounting	1
40	100016	WASHER, lock, 1/4"	2	290	C33037	TAPE, fiberglass, 0.5" wide (229 mm)	9"
50				300	C19810	SCREW, soc. hd. cap, 1/4" - 20 x 1	2
60	C34044	PLATE, blank-off	1	310	104594	SCREW, soc. hd. cap, 1/4" - 20 x 3.25	4
70*	C34032	SEAL	1	320✓	C32255	SENSOR, RTD	1
80	C34030	SPACER	4	330	C34043	BRACKET	1
90*	113944	O-RING, -125 flouroelastomer	1	350	C19949	SCREW, pan hd. machine, #4 - 40 x 0.5	2
100*	103649	O-RING, -123 flouroelastomer	1	360	115861	HOUSING, conn.	1
110*	C32088	RING	1	370	C34041	SPRING	1
120	112248	NUT, hex	1	380	065345	WIRE, high temp. (127 mm)	5"
125	C19359	SCREW, set	1	390	101674	TERMINAL, ring	1
130*	C20521	SEAL, thread	1	410	C51774	SEAT	1
140✓	C32082	NEEDLE, piston	1	430	115860	INSERT, male	1
150				440	115862	CONNECTOR, male	1
160				460	112144	SCREW	1
170				510	157021	WASHER, lock	1
180	C34045	SPACER	2	520	116640	CONNECTOR	4
190	C32097	BODY	1				
200	112166	SCREW, soc. hd. cap, 1/4" - 20 x 0.75	2				
210	C19197	WASHER, flat, 3/16	6				
220	C34040	COVER	1				
230	C19269	SCREW, fill. hd. machine, #4 - 40 x 0.25	2				
240	C32085	BASE, cylinder	1				
250*	103337	O-RING, -010 fluoroelastomer	1				

* These parts are included in Repair Kit 17S172, which may be purchased separately.

✓ Keep these spare parts on hand to reduce down time.

NOTE: For Series A or B valves, use Kit C50594.

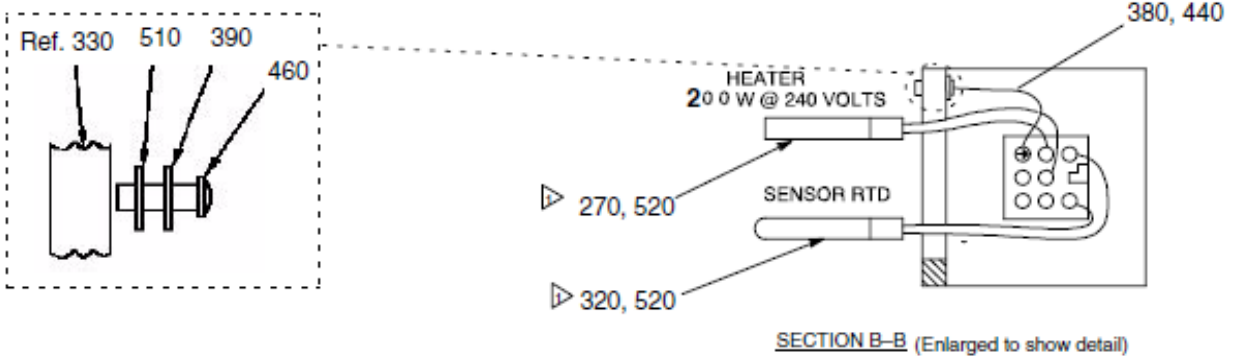

Notes

- ▶ Coat with heat sink compound (400) before installing.

Model 243696, Therm-O-Flow Automatic Dispense Valve with Snuff Back

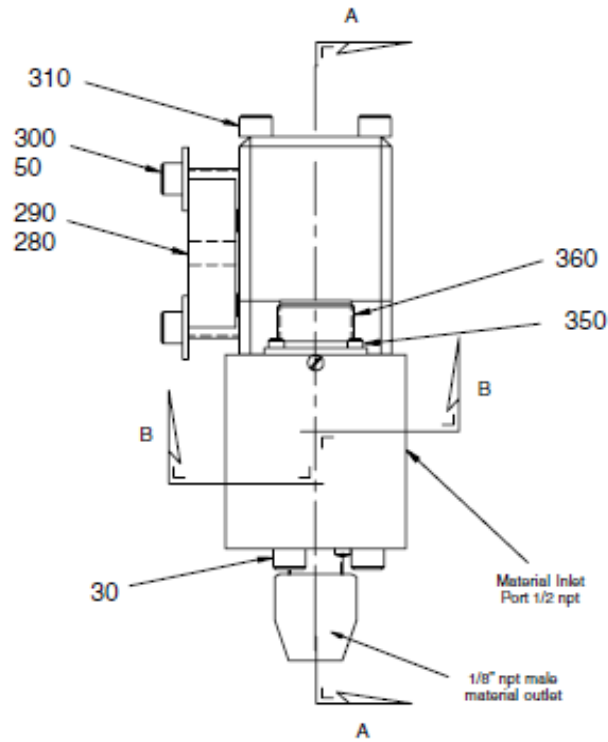
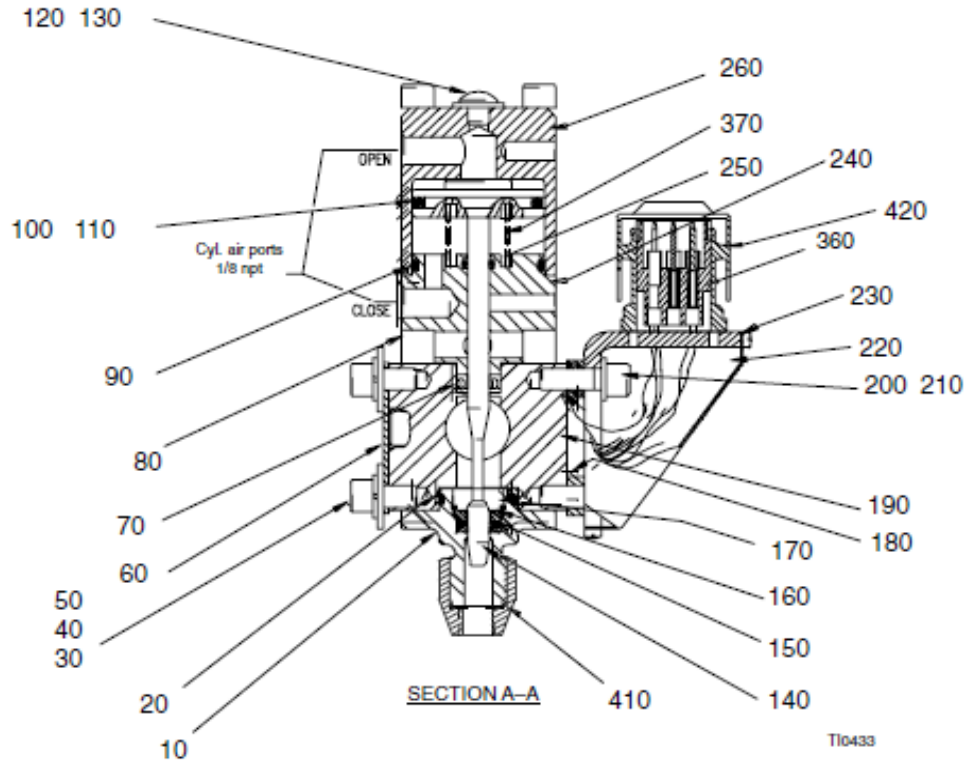

Model 243696, Therm-O-Flow Automatic Dispense Valve with Snuff Back

Ref No.	Part No.	Description	Qty.	Ref No.	Part No.	Description	Qty.
10	617479	ADAPTER, seat	1	260	C34028	CAP, cylinder	1
20*	16D530	O-RING	1	270✓	116011	HEATER, cartridge 230V, 200W	1
30	C19800	SCREW, soc. hd. cap	5	280	C32099	BLOCK, mounting	1
40	100016	WASHER, lock, 1/4"	2	290	C33037	TAPE, fiberglass, 0.5" wide (229 mm)	9"
50	110755	WASHER, flat, 1/4"	4	300	C19810	SCREW, soc. hd. cap, 1/4" - 20 x 1	2
60	C34044	PLATE, blank-off	1	310	104594	SCREW, soc. hd. cap, 1/4" - 20 x 3.25	4
70*	617604	SEAL, PTFE, 0.25 x 0.44	1	320✓	C32255	SENSOR, RTD	1
80	C34030	SPACER	4	330	C34043	BRACKET	1
90*	113944	O-RING, -125 flouroelastomer	1	340	112144	SCREW	1
100*	103649	O-RING, -123 flouroelastomer	1	350	C19949	SCREW, pan hd. machine, #4 - 40 x 0.5	2
110*	C32088	RING	1	360	115860	INSERT, male	1
120	617495	SCREW, button head, 1/4" - 20 x 0.31	1	370*	617536	SPRING	1
130*	C20521	SEAL, thread	1	390	065345	WIRE, high temp, (127 mm)	5"
140✓	918471	NEEDLE, assembly	1	400	101674	TERMINAL, ring	1
150*	617491	SEAL, rod hi temp, 0.25 x 0.50 x 0.25	1	410	C32089	NUT, nozzle	1
160	617480	SPACER	1	420	115861	HOUSING, connector	1
170*	C20406	RING, retaining, for 0.56 I.D.	1	430	115862	CONNECTOR, male	1
180	C34045	SPACER	2	510	157021	WASHER, lock	1
190	617605	BODY	1	520	116640	CONNECTOR	4
200	112166	SCREW, soc. hd. cap, 1/4" - 20 x 0.75	2				
210	C19197	WASHER, flat, 3/16	2				
220	C34040	COVER	1				
230	C19269	SCREW, fill. hd. machine, #4 - 40 x 0.25	2				
240	617603	BASE, cylinder	1				
250*	103337	O-RING, -010 fluoroelastomer	1				

* These parts are included in Repair Kit 918520, which may be purchased separately.
 ✓ Keep these spare parts on hand to reduce down time.

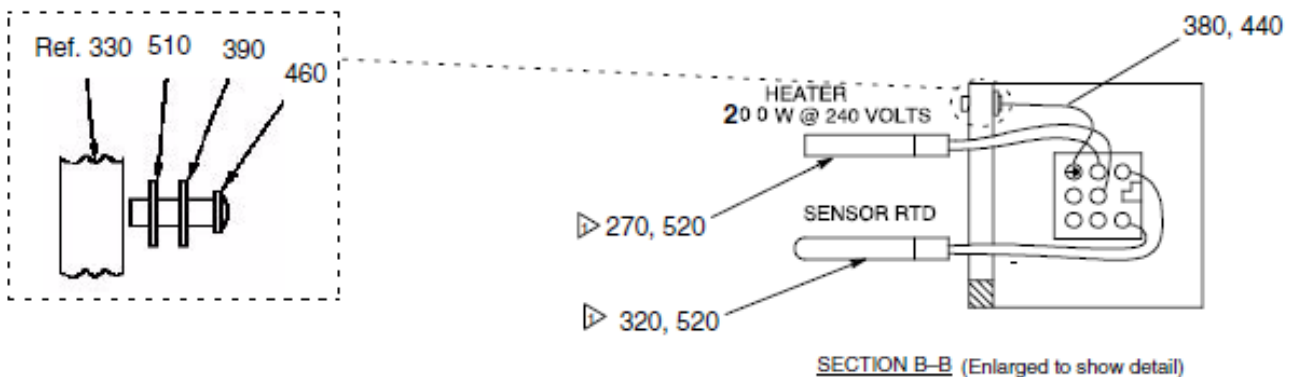

Notes
 ▷ Coat with heat sink compound (400) before installing.

Model C27340, Ambient Therm-O-Flow Automatic Dispense Valve, Double Acting

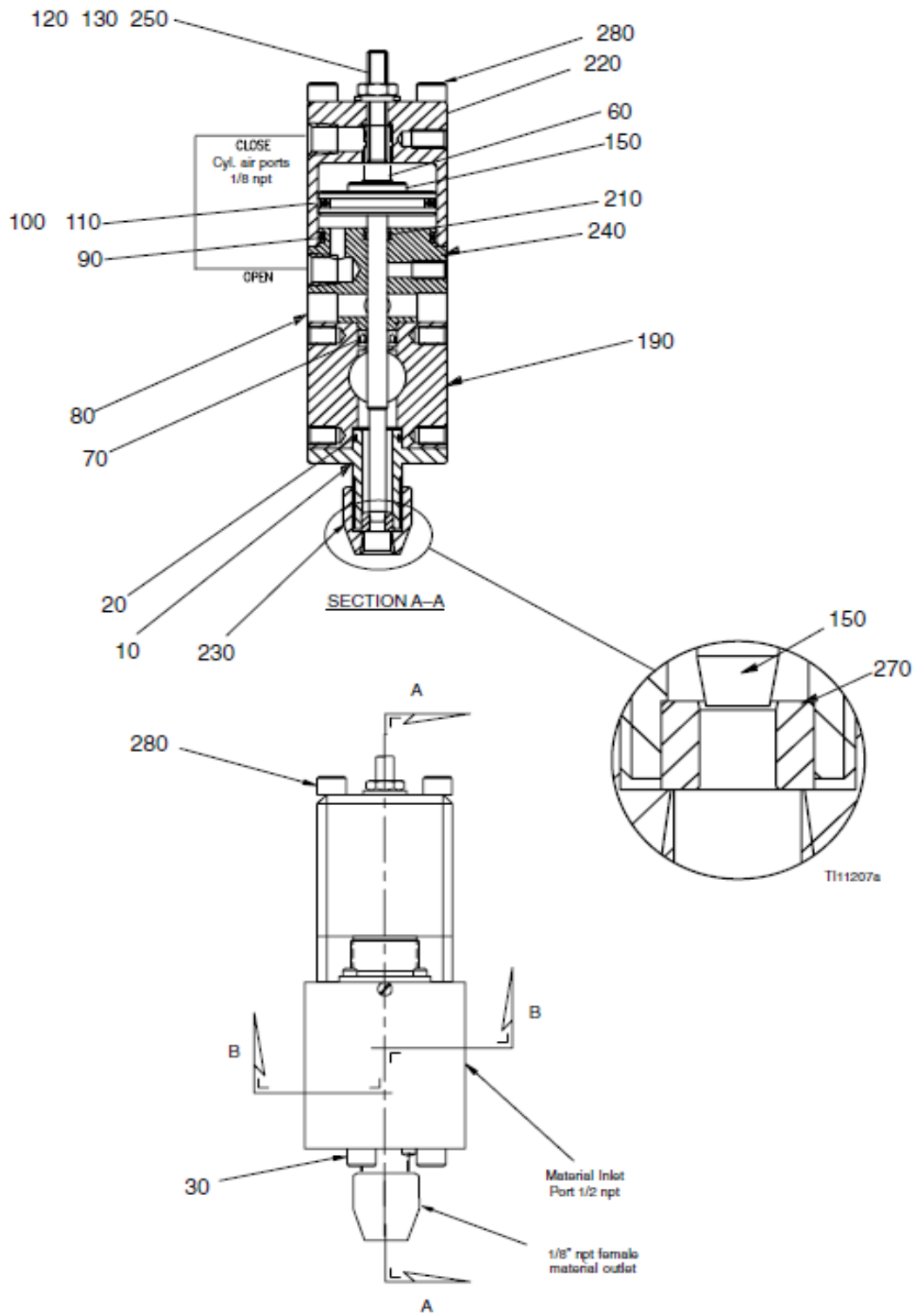

Model C27340, Ambient Therm-O-Flow Automatic Dispense Valve, Double Acting

Ref				Ref			
No.	Part No.	Description	Qty.	No.	Part No.	Description	Qty.
10	C32083	ADAPTER, seat	1	150✓	C32082	NEEDLE assembly	1
20	103610	O-RING, -018 flouroelastomer	1	190	C32097	BODY	1
30	C19800	SCREW, soc. hd. cap, 1/4" - 20 x 0.5	3	210	103337	O-RING, -010 fluoroelastomer	1
60	C34041	SPRING	1	220	C34028	CAP, cylinder	1
70	C34032	SEAL	1	230	C32089	RETAINER	1
80	C34030	SPACER	4	240	C32085	BASE, cylinder	1
90	113944	O-RING, -123 flouroelastomer	1	250	C20521	SEAL, thread	1
100	103649	O-RING	1	270	C32090	SEAT	1
110	C32088	GLIDE RING	1	280	104594	SCREW, soc. hd.	4
120	C19359	SCREW, set, 1/4" - 20 x 1.5	1				
130	112248	NUT, hex, 1/4" - 20	1				

✓ *Keep these spare parts on hand to reduce down time*

Model C34068, Warm Automatic Dispense Valve, Double Acting

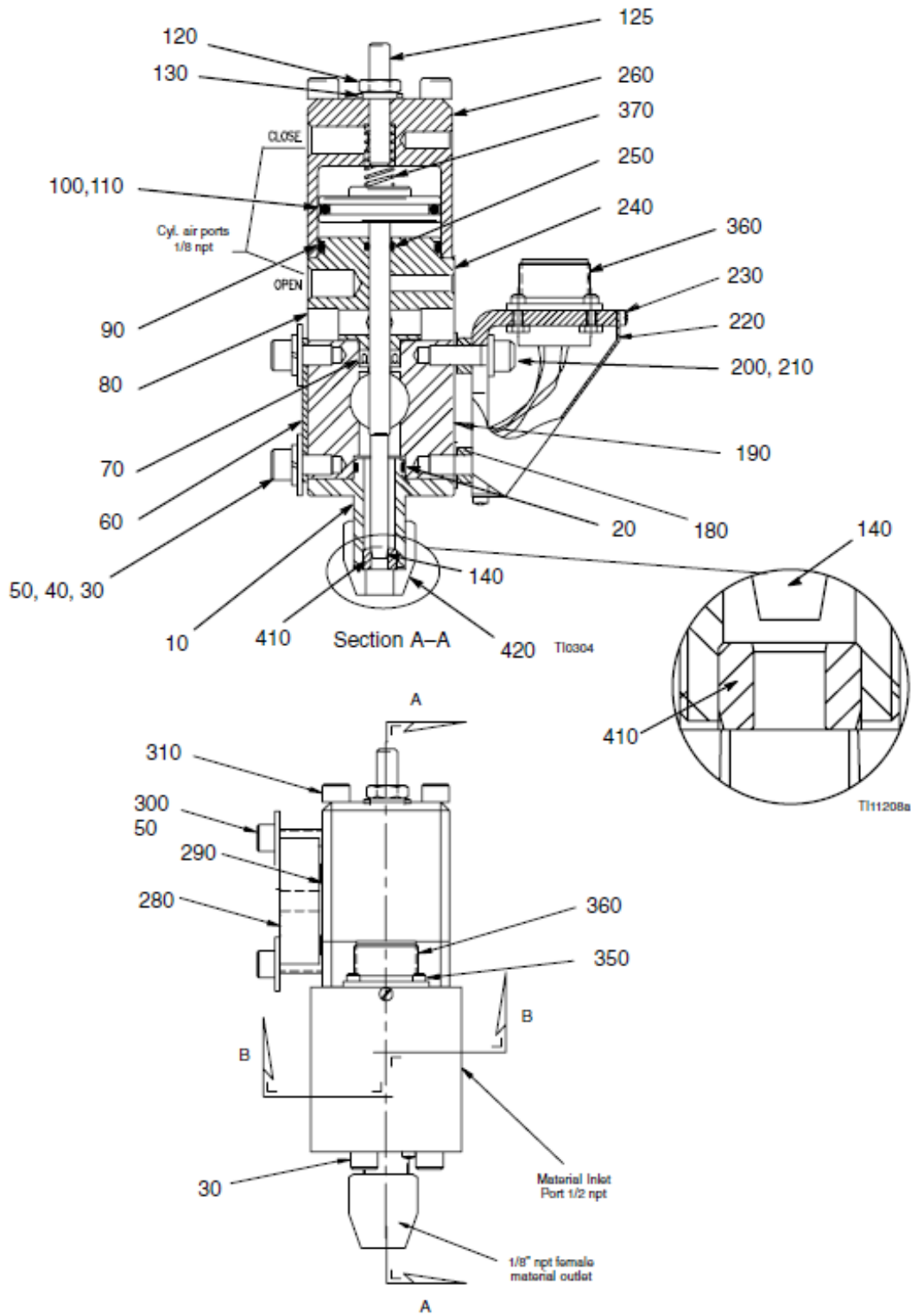

Model C34068, Warm (275°F/135°C max) Automatic Dispense Valve with Snuff Back

Ref No.	Part No.	Description	Qty.	Ref No.	Part No.	Description	Qty.
10	C32083	ADAPTER, seat	1	270✓	C31034	HEATER, cartridge 120V, 150W	1
20*	103610	O-RING, -018 flouroelastomer	1	280	C32099	BLOCK, mounting	1
30	C19800	SCREW, soc. hd. cap, 1/4" - 20 x 0.5	5	290	C33037	TAPE, fiberglass, 0.5" wide (229 mm)	9"
40	100016	WASHER, lock, 1/4"	2	300	C19810	SCREW, soc. hd. cap, 1/4" - 20 x 1	2
50	110755	WASHER, flat, 1/4"	4	310	104594	SCREW, soc. hd. cap, 1/4" - 20 x 3.25	4
60	C34044	PLATE, blank-off	1	320✓	C32255	SENSOR, RTD	1
70*	C34032	SEAL, graphite/PTFE	1	330	C34043	BRACKET	1
80	C34030	SPACER	4	340	102794	NUT, hex, #4 - 40	1
90*	113944	O-RING, -125 flouroelastomer	1	350	C19270	SCREW, fill. hd. machine, #4 - 40 x 0.38	2
100*	103649	O-RING, -123 flouroelastomer	1	360	C07329	CONNECTOR, 6 pin	1
110*	C32088	RING	1	370	C34041	SPRING	1
120	112248	NUT, hex	1	380	065345	WIRE, high temp. (127 mm)	5"
125	C19359	SCREW, set	1	390	101674	TERMINAL, ring	1
130*	C20521	SEAL, thread	1	400	073019	COMPOUND, heat sink (not shown)	1
140✓	C32082	NEEDLE, assembly	1	410	C32090	SEAT	1
180	C34045	SPACER	2	420	C32089	NUT, retainer	1
190	C32097	BODY	1	460	112144	SCREW	1
200	112166	SCREW, soc. hd. cap, 1/4" - 20 x 0.75	2	510	157021	WASHER, lock	1
210	C19197	WASHER, flat, 3/16	6				
220	C34040	COVER	1				
230	C19269	SCREW, fill. hd. machine, #4 - 40 x 0.25	2				
240	C32085	BASE, cylinder	1				
250*	103337	O-RING, -010 fluoroelastomer	1				
260	C34028	CAP, cylinder	1				

* These parts are included in Repair Kit C27342, which may be purchased separately.

✓ Keep these spare parts on hand to reduce down time.

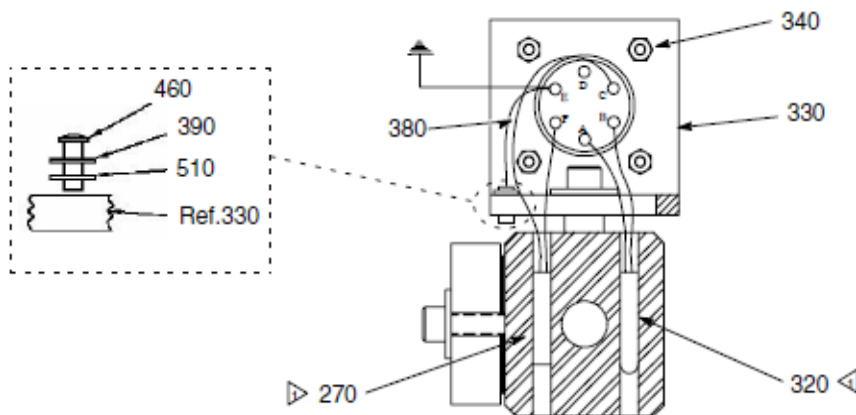

SECTION B-B (Enlarged to show detail)

Notes

- ▶ Coat with heat sink compound (400) before installing.

Model C34079, Therm-O-Flow Automatic Dispense Valve, Double Acting

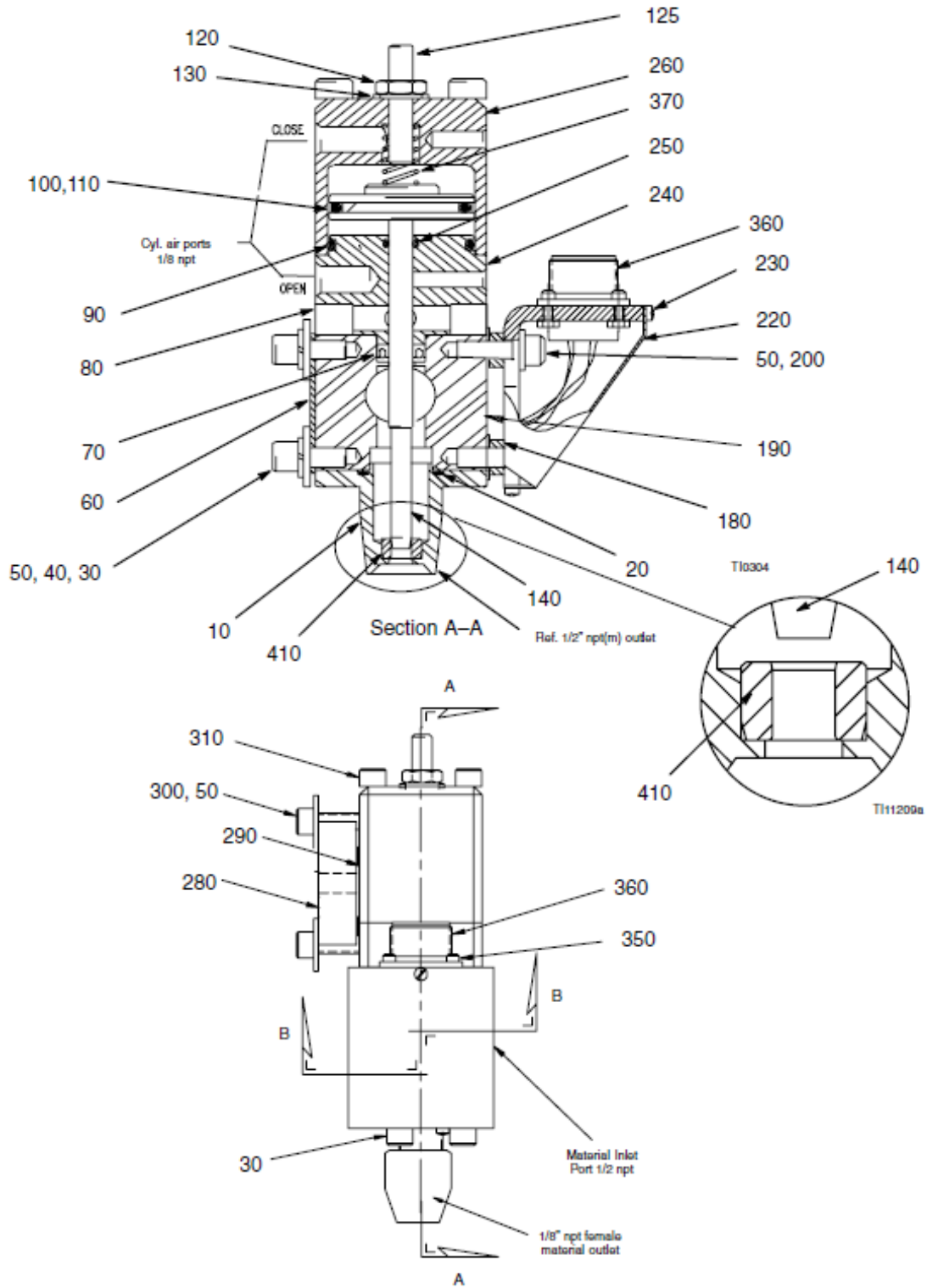

Model C34079, Therm-O-Flow Automatic Dispense Valve, Double Acting

Ref No.	Part No.	Description	Qty.	Ref No.	Part No.	Description	Qty.
10	C51762	ADAPTER, seat	1	270✓	C31034	HEATER, cartridge 120V, 150W	1
20*	16D530	O-RING	1	280	C32099	BLOCK, mounting	1
30	C19800	SCREW, soc. hd. cap, 1/4" - 20 x 0.5	5	290	C33037	TAPE, fiberglass, 0.5" wide (229 mm)	9"
40	100016	WASHER, lock, 1/4"	2	300	C19810	SCREW, soc. hd. cap, 1/4" - 20 x 1	2
50	C19197	WASHER, flat, 1/4"	6	310	104594	SCREW, soc. hd. cap, 1/4" - 20 x 3.25	4
60	C34044	PLATE, blank-off	1	320✓	C32255	SENSOR, RTD	1
70*	C34032	SEAL, graphite/PTFE	1	330	C34043	BRACKET	1
80	C34030	SPACER	4	340	102794	NUT, hex, #4 - 40	4
90*	113944	O-RING, -125 flouroelastomer	1	350	113970	SCREW, machine, #4 - 40	4
100*	103649	O-RING, -123 flouroelastomer	1	360	C07329	CONNECTOR, 6 pin	1
110*	C32088	RING	1	370	C34041	SPRING	1
120	112248	NUT, hex	1	380	065345	WIRE, high temp. (127 mm)	5"
125	C19359	SCREW, set	1	390	101674	TERMINAL, ring	1
130*	C20521	SEAL, thread	1	400	073019	COMPOUND, heat sink (not shown)	A/R
140✓	C32082	NEEDLE, assembly	1	410	C51774	SEAT	1
180	C34045	SPACER	2	460	112144	SCREW	1
190	C32097	BODY	1	510	157021	WASHER, lock	1
200	112166	SCREW, soc. hd. cap, 1/4" - 20 x 0.75	2				
220	C34040	COVER	1				
230	C19269	SCREW, fill. hd. machine, #4 - 40 x 0.25	2				
240	C32085	BASE, cylinder	1				
250*	103337	O-RING, -010 fluoroelastomer	1				
260	C34028	CAP, cylinder	1				

* These parts are included in Repair Kit C34080, which may be purchased separately.

✓ Keep these spare parts on hand to reduce down time.

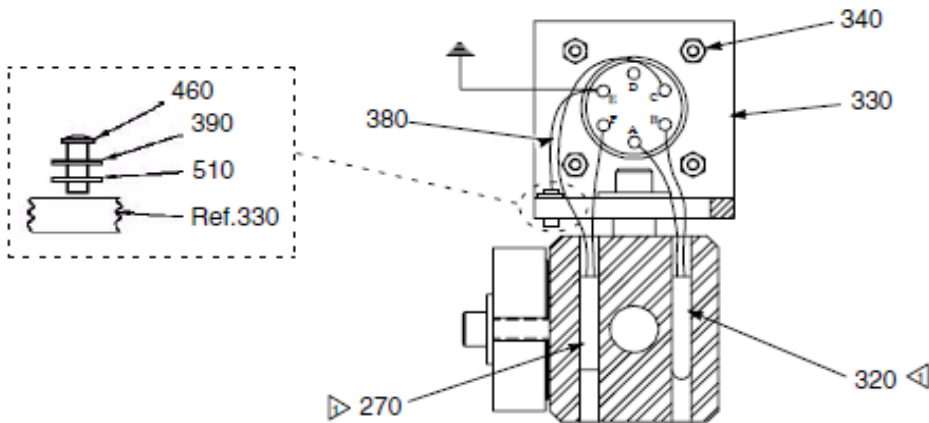

SECTION B-B (Enlarged to show detail)

Notes

- ▶ Coat with heat sink compound (400) before installing.

Model C50592, Therm-O-Flow Automatic Dispense Valve, Double Acting

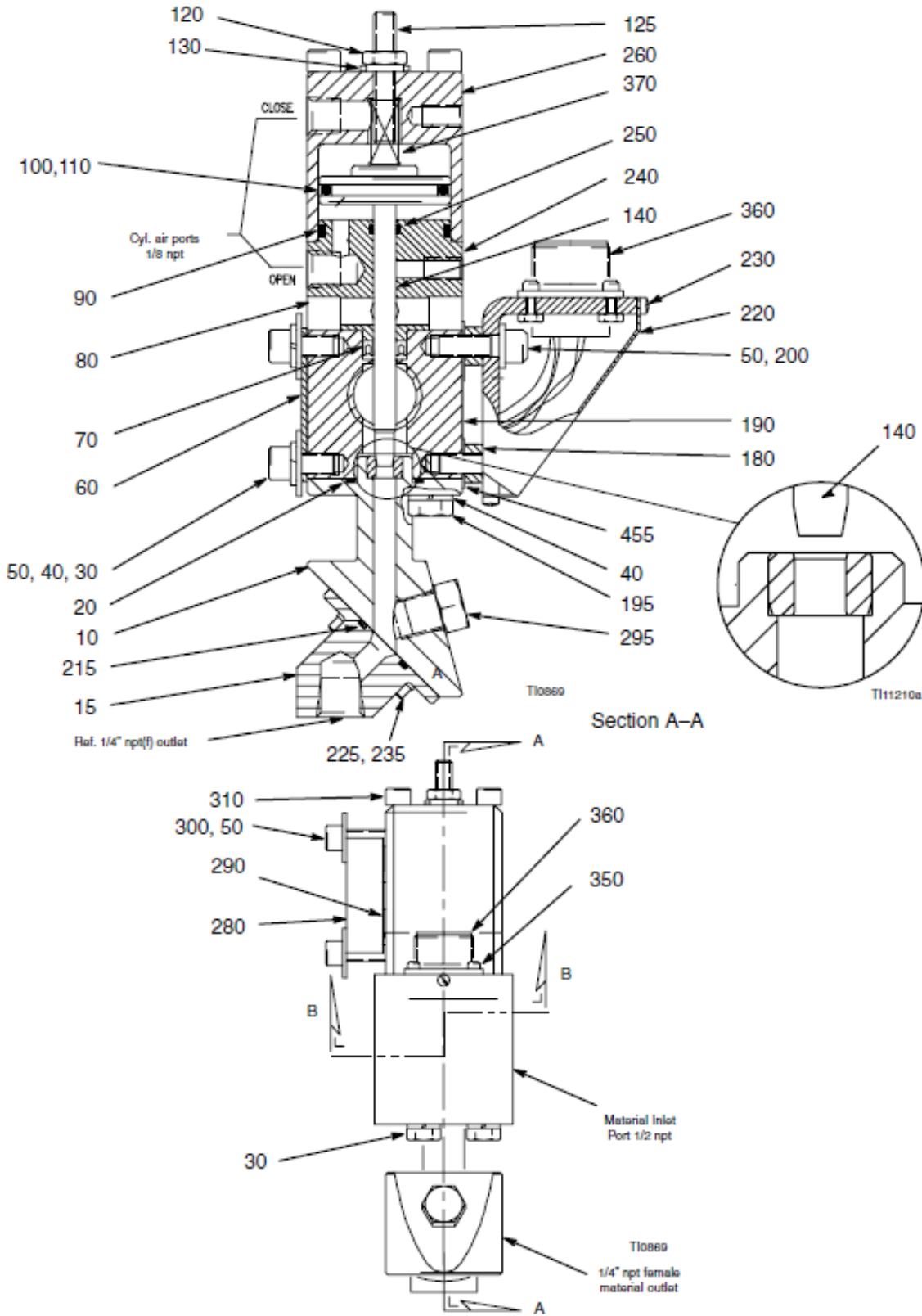

Model C50592, Therm-O-Flow Automatic Dispense Valve, Double Acting

Ref No.	Part No.	Description	Qty.	Ref No.	Part No.	Description	Qty.
10	C50881	ADAPTER, nozzle manifold	1	250*	103337	O-RING, -010 fluoroelastomer	1
15	C50582	MANIFOLD, nozzle	1	260	C34028	CAP, cylinder	1
20*	16D530	O-RING	1	270✓	C31034	HEATER, cartridge 120V, 150W	1
30	C19800	SCREW, soc. hd. cap, 1/4" - 20 x 0.5	2	280	C32099	BLOCK, mounting	1
40	100016	WASHER, lock, 1/4"	5	290	C33037	TAPE, fiberglass, 0.5" wide (229 mm)	11"
50	C19197	WASHER, flat, 1/4"	6	295	C38014	PLUG, o-ring boss	1
60	C34044	PLATE, blank-off	1	300	C19810	SCREW, soc. hd. cap, 1/4" - 20 x 1	2
70*	C34032	SEAL, graphite, PTFE	1	310	104594	SCREW, soc. hd. cap, 1/4" - 20 x 3.25	4
80	C34030	SPACER	4	320✓	C32255	SENSOR, temperature	1
90*	113944	O-RING, -125 fluoroelastomer	1	330	C34043	BRACKET	1
100*	103649	O-RING, -123 fluoroelastomer	1	340	102794	NUT, hex, #4 - 40	4
110*	C32088	RING, piston	1	350	113970	SCREW, machine, #4 - 40	4
120	112248	NUT, hex	1	360	C07329	CONNECTOR, 6 pin	1
125	C19359	SCREW, set	1	370	C34041	SPRING	1
130*	C20521	SEAL, thread	1	380	065345	WIRE, lead, motor	5"
140✓	C50583	NEEDLE, assembly	1	390	101674	TERMINAL, ring	1
180	C34045	SPACER	2	400	073019	COMPOUND, heat sink (not shown)	A/R
190	C32097	BODY	1	460	112144	SCREW	1
195	100333	SCREW, cap, hex. hd.	3	510	157021	WASHER, lock	1
200	112166	SCREW, soc. hd. cap, 1/4" - 20 x 0.75	2				
215*	109576	O-RING, fluoroelastomer	1				
220	C34040	COVER	1				
225	112788	SCREW, soc. hd. cap	4				
230	C19269	SCREW, fill. hd. machine, #4 - 40 x 0.25	2				
235	100079	WASHER, lock, spring	4				
240	C32085	BASE, cylinder	1				

* These parts are included in Repair Kit C50594, which may be purchased separately.
 ✓ Keep these spare parts on hand to reduce down time.

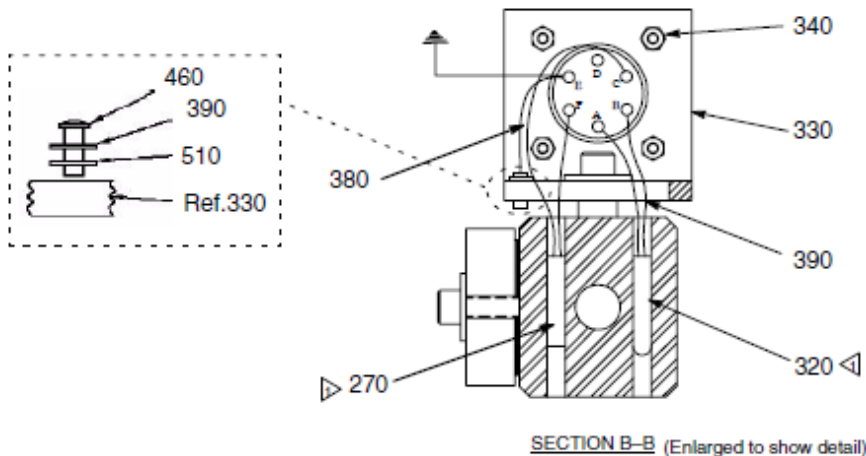

Notes
 ▷ Coat with heat sink compound (400) before installing.

Accessories

Use Only Genuine Graco Parts and Accessories

Description

Part No.

LOW PRESSURE HEATED HOSES

14 MPa (138 bar, 2000 psi) Heated hoses for use with Therm-O-Flow® 5 and Therm-O-Flow 55 supply units. Contact your Graco Service Representative for more information.

HIGH PRESSURE HEATED HOSES

28 MPa (275 bar, 4000 psi) Heated hoses for use with Therm-O-Flow 5 and Therm-O-Flow 55 supply units. Contact your Graco Service Representative for more information.

HOSE FITTINGS

For use with heated hoses. Do not use fittings with temperature ratings that are lower than the operating temperature of your system. Contact your Graco Service Representative for more information.

#8–37° SAE [3/4–16 (m)] x 1/2 npt male adapter

C20700

#10–37° SAE [7/8–14 (m)] x 1/2 npt male adapter

C20703

NOTE: The following accessories are not applicable to Model 297266.

EXTRUSION NOZZLE ADAPTER NUT [5/8-18(f) x 1/8 npt(f)]

C32089

Adapts 1/8"–27 npt (m) nozzles to dispense valve. Accepts the adapter nut. 5/8–18F X 1/8 npt(f) nozzles listed below. Contact your Graco Service Representative for more information.

Description	Length	Orifice	Thread	Part No.
Nozzle	2"	Ø 3/32"	1/8" npt	161505
	2"	Ø 1/84"		607665
	2 1/8"	Ø 1/8"		164799
	2-7/16"	Ø 3/32" x 3/8"		C01025
	1-7/32"	Ø 1/8"		C17009

STREAMING TIP ADAPTERS

617585

Ø 0.469 opening adapter for automatic dispense valve. Use tips listed below. The last 3 digits of the part number indicate the orifice size. Contact your Graco Service Representative for streaming tip selection.

Orifice Size (inches)	Part No.	Orifice Size (inches)	Part No.
Odd sizes .025" through .047"			
0.25	270025	.061	270061
0.37	270037	.063	270063
0.47	270047	.065	270065
		.067	270067
		.077	270077

AIR FITTINGS

Suggested air fittings for automatic dispense valve air inlet ports. Do not use fittings with temperature ratings that are lower than the operating temperature of your system. Contact your Graco Service Representative for more information.

Description	NPT	Tube	Part No.
90° elbow, brass push-in tube	1/8" male	1/4" O.D.	C19389

SOLENOID VALVE KITS

For heated double acting air actuated valves. Includes solenoid, 24" high temperature air tubes, air fittings, and muffler.

Coil Voltage	Part No.
120 Volt AC	C58942
230 Volt AC	243703
24 Volt DC	C59038

SWIRL ASSEMBLIES

For Model 297266 only.

Description	Orifice Size (in.)	Part No.
Swirl applicator head	n/a	118072
Swirl nozzle	.030	117950
Swirl nozzle	.045	117951
Swirl nozzle	.060	117952
Swirl nozzle	.080	117953

Dimensions

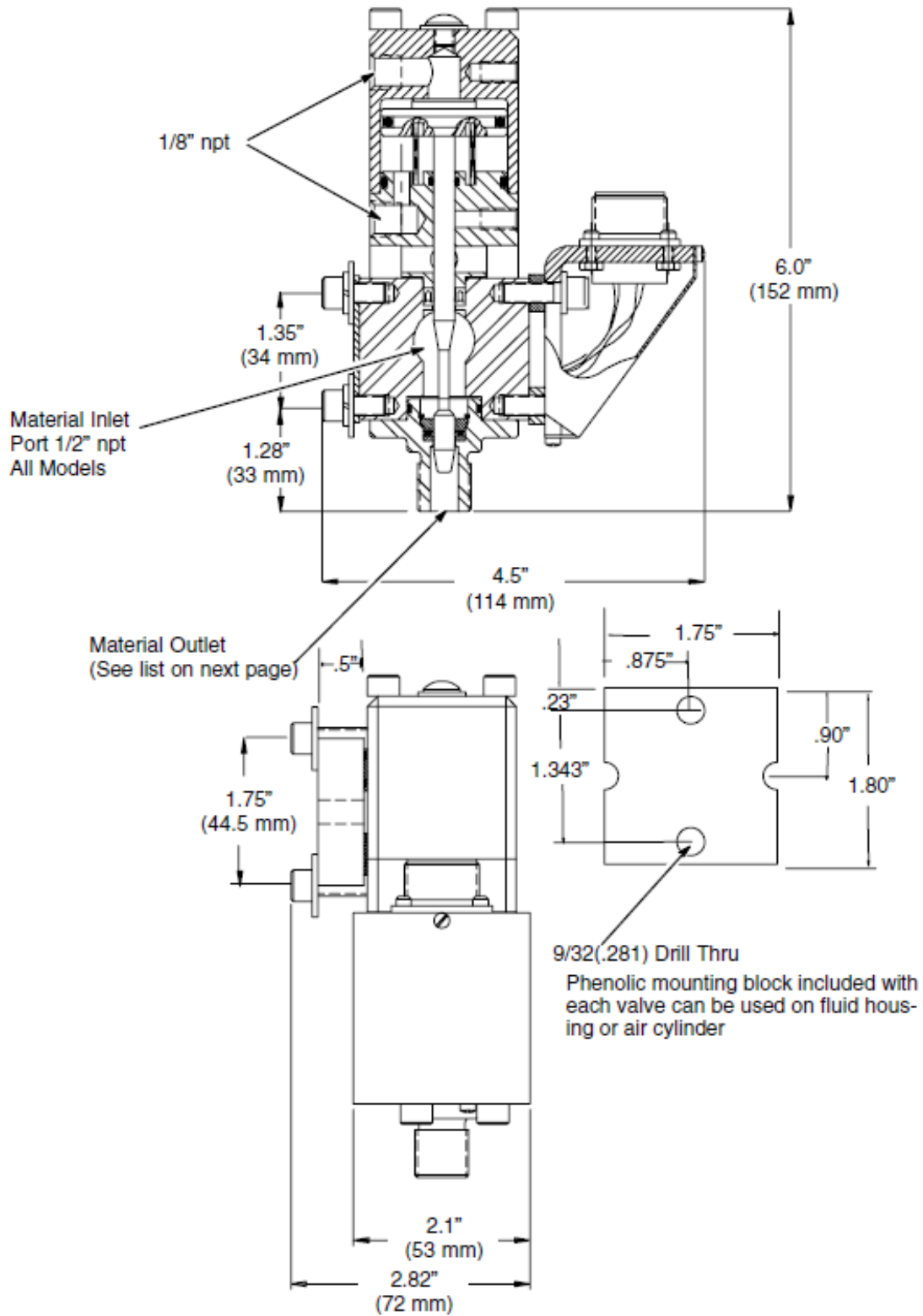

Technical Data

Maximum working dry air pressure	1 MPa (10 bar, 150 psi)
Material Inlet (to conditioning manifold)	1/2" npt
Air Inlet	1/8" npt
120 Volt Heater (Models C34068, C34079, C50592, 194485, 918483, 918512, and 918639)	150w @ 120 Vac, 96 ohms +/-10
240 Volt Heater (Models 243694, 243695, 243696, and 297266)	200w @ 240 Vac, 288 ohms +30/-40
RTD Sensor	100 Ohm platinum RTD, 0.00385 ohm/ohm/deg C (108.2 ohms @ 21° C (70° F))
Weight (automatic dispense valve + connector)	approx. 1.8 kg (4 lbs)

Fluid Seal Material	Part No.	Max. Temp.	Maximum Fluid Working Pressure	Maximum Air Input Pressure	Parts Page
Polymite/fluoroelastomer	194485	135° C (275° F)	241 bar, 24 MPa (3500 psi)	10 bar, 1MPa (150 psi)	20
PTFE/fluoroelastomer	918483	205° C (400° F)	241 bar, 24 MPa (3500 psi)	10 bar, 1MPa (150 psi)	22
PTFE/fluoroelastomer	918512	205° C (400° F)	241 bar, 24 MPa (3500 psi)	10 bar, 1MPa (150 psi)	24
PTFE/fluoroelastomer	918639	205° C (400° F)	241 bar, 24 MPa (3500 psi)	10 bar, 1MPa (150 psi)	26
PTFE/fluoroelastomer	243694	205° C (400° F)	241 bar, 24 MPa (3500 psi)	10 bar, 1MPa (150 psi)	28
PTFE/fluoroelastomer	297266	205° C (400° F)	241 bar, 24 MPa (3500 psi)	10 bar, 1MPa (150 psi)	30
PTFE/fluoroelastomer	243695	205° C (400° F)	241 bar, 24 MPa (3500 psi)	10 bar, 1MPa (150 psi)	31
PTFE/fluoroelastomer	243696	205° C (400° F)	241 bar, 24 MPa (3500 psi)	10 bar, 1MPa (150 psi)	33
PTFE/fluoroelastomer	C27340	205° C (400° F)	241 bar, 24 MPa (3500 psi)	10 bar, 1MPa (150 psi)	35
PTFE/fluoroelastomer	C34068	205° C (400° F)	241 bar, 24 MPa (3500 psi)	10 bar, 1MPa (150 psi)	37
PTFE/fluoroelastomer	C34079	205° C (400° F)	241 bar, 24 MPa (3500 psi)	10 bar, 1MPa (150 psi)	39
PTFE/fluoroelastomer	C50592	205° C (400° F)	241 bar, 24 MPa (3500 psi)	10 bar, 1MPa (150 psi)	41

WETTED PARTS (all values)

Stainless Steel, plated carbon steel, chrome, brass.

PrecisionFlo™ is a trademark of Graco, Inc.

PARKER O LUBE is a trademark of Parker Seal.

POLYMITE is a trademark of Parker Seal.

Material Outlet	
C34079 and 243695	1/2 npt(m)
194485, 918483	5/8-18 thread to accept nozzle retaining nuts
918512, 243694, and 243696	Nozzle retaining nut with 1/8 npt(f)
918639	3/4-16 (37°SAE #8)

Graco Standard Warranty

Graco warrants all equipment referenced in this document which is manufactured by Graco and bearing its name to be free from defects in material and workmanship on the date of sale to the original purchaser for use. With the exception of any special, extended, or limited warranty published by Graco, Graco will, for a period of twelve months from the date of sale, repair or replace any part of the equipment determined by Graco to be defective. This warranty applies only when the equipment is installed, operated and maintained in accordance with Graco's written recommendations.

This warranty does not cover, and Graco shall not be liable for general wear and tear, or any malfunction, damage or wear caused by faulty installation, misapplication, abrasion, corrosion, inadequate or improper maintenance, negligence, accident, tampering, or substitution of non-Graco component parts. Nor shall Graco be liable for malfunction, damage or wear caused by the incompatibility of Graco equipment with structures, accessories, equipment or materials not supplied by Graco, or the improper design, manufacture, installation, operation or maintenance of structures, accessories, equipment or materials not supplied by Graco.

This warranty is conditioned upon the prepaid return of the equipment claimed to be defective to an authorized Graco distributor for verification of the claimed defect. If the claimed defect is verified, Graco will repair or replace free of charge any defective parts. The equipment will be returned to the original purchaser transportation prepaid. If inspection of the equipment does not disclose any defect in material or workmanship, repairs will be made at a reasonable charge, which charges may include the costs of parts, labor, and transportation.

THIS WARRANTY IS EXCLUSIVE, AND IS IN LIEU OF ANY OTHER WARRANTIES, EXPRESS OR IMPLIED, INCLUDING BUT NOT LIMITED TO WARRANTY OF MERCHANTABILITY OR WARRANTY OF FITNESS FOR A PARTICULAR PURPOSE.

Graco's sole obligation and buyer's sole remedy for any breach of warranty shall be as set forth above. The buyer agrees that no other remedy (including, but not limited to, incidental or consequential damages for lost profits, lost sales, injury to person or property, or any other incidental or consequential loss) shall be available. Any action for breach of warranty must be brought within two (2) years of the date of sale.

GRACO MAKES NO WARRANTY, AND DISCLAIMS ALL IMPLIED WARRANTIES OF MERCHANTABILITY AND FITNESS FOR A PARTICULAR PURPOSE, IN CONNECTION WITH ACCESSORIES, EQUIPMENT, MATERIALS OR COMPONENTS SOLD BUT NOT MANUFACTURED BY GRACO. These items sold, but not manufactured by Graco (such as electric motors, switches, hose, etc.), are subject to the warranty, if any, of their manufacturer. Graco will provide purchaser with reasonable assistance in making any claim for breach of these warranties.

In no event will Graco be liable for indirect, incidental, special or consequential damages resulting from Graco supplying equipment hereunder, or the furnishing, performance, or use of any products or other goods sold hereto, whether due to a breach of contract, breach of warranty, the negligence of Graco, or otherwise.

FOR GRACO CANADA CUSTOMERS

The Parties acknowledge that they have required that the present document, as well as all documents, notices and legal proceedings entered into, given or instituted pursuant hereto or relating directly or indirectly hereto, be drawn up in English. Les parties reconnaissent avoir convenu que la rédaction du présente document sera en Anglais, ainsi que tous documents, avis et procédures judiciaires exécutés, donnés ou intentés, à la suite de ou en rapport, directement ou indirectement, avec les procédures concernées.

Graco Information

For the latest information about Graco products, visit www.graco.com.

For patent information, see www.graco.com/patents.

TO PLACE AN ORDER, contact your Graco distributor or call to identify the nearest distributor.

Phone: 612-623-6921 or Toll Free: 1-800-328-0211 Fax: 612-378-3505

All written and visual data contained in this document reflects the latest product information available at the time of publication. Graco reserves the right to make changes at any time without notice.

Original instructions. This manual contains English. MM 310538

Graco Headquarters: Minneapolis

International Offices: Belgium, China, Japan, Korea

GRACO INC. AND SUBSIDIARIES • P.O. BOX 1441 • MINNEAPOLIS MN 55440-1441 • USA

Copyright 1997, Graco Inc. All Graco manufacturing locations are registered to ISO 9001.

www.graco.com

Revision T, August 2017