



InvisiPac® GS35 Plug-Free™

Hot Melt Applicator

3A2805M
EN

For dispensing hot melt adhesive. For professional use only. Not for use in waterwash environments.

Not approved for use in explosive atmospheres or hazardous locations.



Important Safety Instructions

Read all warnings and instructions in this manual. Save these instructions.

1500 psi (10.3 MPa, 103 bar) Maximum Working Fluid Pressure

80 psi (0.5 MPa, 5.5 bar) Maximum Air Pressure

See page 6 for models and approval information.

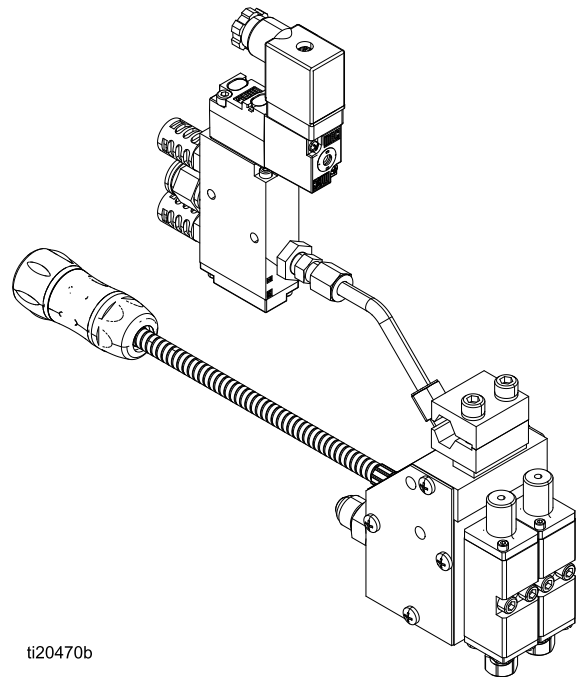







ti20470b

Contents

Warnings	3	Check Module.....	16
Approvals.....	5	Check Nozzle and Module.....	16
Models.....	6	Check Heater	17
Component Identification.....	7	Check RTD.....	17
Overview.....	8	Check Thermal Cutoff	18
Grounding.....	8	Repair.....	19
Installation.....	9	Before Beginning Repair.....	19
Mounting	9	Replace Heater Cartridge	20
Connect Heated Hose	9	Replace RTD.....	20
Connect Solenoid Valve	9	Replace Thermal Cutoff.....	20
Connect Triggering Device	10	Replace Cordset.....	22
Prime Before Using Equipment	10	Replace Solenoid Valve	24
Flush.....	11	Replace Module.....	24
Install Nozzle	11	Replace Applicator	24
Select RTD.....	11	Notes	25
Operation.....	12	Parts.....	26
Pressure Relief Procedure.....	12	Kits and Accessories.....	44
Maintenance	13	Dimensions	46
Replace Inlet Filter	13	Technical Data	50
Filter Maintenance Guidelines.....	13	Notes	51
Troubleshooting.....	14	Graco Extended Warranty	52

Warnings

The following warnings are for the setup, use, grounding, maintenance, and repair of this equipment. The exclamation point symbol alerts you to a general warning and the hazard symbols refer to procedure-specific risks. When these symbols appear in the body of this manual or on warning labels, refer back to these Warnings. Product-specific hazard symbols and warnings not covered in this section may appear throughout the body of this manual where applicable.

 <h2 style="margin: 0;">WARNING</h2>	
	<p>BURN HAZARD</p> <p>Equipment surfaces and fluid that's heated can become very hot during operation. To avoid severe burns:</p> <ul style="list-style-type: none"> • Do not touch hot fluid or equipment.
 	<p>ELECTRIC SHOCK HAZARD</p> <p>This equipment must be grounded. Improper grounding, setup, or usage of the system can cause electric shock.</p> <ul style="list-style-type: none"> • Turn off and disconnect power at main switch before disconnecting any cables and before servicing equipment. • Connect only to grounded power source. • All electrical wiring must be done by a qualified electrician and comply with all local codes and regulations.
  	<p>SKIN INJECTION HAZARD</p> <p>High-pressure fluid from dispensing device, hose leaks, or ruptured components will pierce skin. This may look like just a cut, but it is a serious injury that can result in amputation. Get immediate surgical treatment.</p> <ul style="list-style-type: none"> • Do not point dispensing device at anyone or at any part of the body. • Do not put your hand over the fluid outlet. • Do not stop or deflect leaks with your hand, body, glove, or rag. • Follow the Pressure Relief Procedure when you stop dispensing and before cleaning, checking, or servicing equipment. • Tighten all fluid connections before operating the equipment. • Check hoses and couplings daily. Replace worn or damaged parts immediately.



WARNING



FIRE AND EXPLOSION HAZARD

Flammable fumes, such as solvent and paint fumes, in **work area** can ignite or explode. To help prevent fire and explosion:



- Use equipment only in well ventilated area.
- Eliminate all ignition sources; such as pilot lights, cigarettes, portable electric lamps, and plastic drop cloths (potential static arc).
- Keep work area free of debris, including solvent, rags and gasoline.
- Do not plug or unplug power cords, or turn power or light switches on or off when flammable fumes are present.
- Ground all equipment in the work area. See **Grounding** instructions.
- Use only grounded hoses.
- Hold gun firmly to side of grounded pail when triggering into pail. Do not use pail liners unless they are antistatic or conductive.
- **Stop operation immediately** if static sparking occurs or you feel a shock. Do not use equipment until you identify and correct the problem.
- Keep a working fire extinguisher in the work area.





EQUIPMENT MISUSE HAZARD

Misuse can cause death or serious injury.



- Do not operate the unit when fatigued or under the influence of drugs or alcohol.
- Do not exceed the maximum working pressure or temperature rating of the lowest rated system component. See **Technical Data** in all equipment manuals.
- Use fluids and solvents that are compatible with equipment wetted parts. See Technical Data in all equipment manuals. Read fluid and solvent manufacturer's warnings. For complete information about your material, request MSDS from distributor or retailer.
- Do not leave the work area while equipment is energized or under pressure.
- Turn off all equipment and follow the **Pressure Relief Procedure** when equipment is not in use.
- Check equipment daily. Repair or replace worn or damaged parts immediately with genuine manufacturer's replacement parts only.
- Do not alter or modify equipment. Alterations or modifications may void agency approvals and create safety hazards.
- Make sure all equipment is rated and approved for the environment in which you are using it.
- Use equipment only for its intended purpose. Call your distributor for information.
- Route hoses and cables away from traffic areas, sharp edges, moving parts, and hot surfaces.
- Do not kink or over bend hoses or use hoses to pull equipment.
- Keep children and animals away from work area.
- Comply with all applicable safety regulations.

 <h1 style="margin: 0;">WARNING</h1>	
	<p>TOXIC FLUID OR FUMES HAZARD</p> <p>Toxic fluids or fumes can cause serious injury or death if splashed in the eyes or on skin, inhaled, or swallowed.</p> <ul style="list-style-type: none"> • Read MSDSs to know the specific hazards of the fluids you are using. • Store hazardous fluid in approved containers, and dispose of it according to applicable guidelines.
	<p>PERSONAL PROTECTIVE EQUIPMENT</p> <p>Wear appropriate protective equipment when in the work area to help prevent serious injury, including eye injury, hearing loss, inhalation of toxic fumes, and burns. This protective equipment includes but is not limited to:</p> <ul style="list-style-type: none"> • Protective eyewear, and hearing protection. • Respirators, protective clothing, and gloves as recommended by the fluid and solvent manufacturer.

Approvals



Intertek
4002346

Conforms to ANSI/UL Std.
499 Certified to CAN/CSA
Std. C22.2 No. 88

Models

All models use a 240 V heater. Additional configurations are available. Contact Graco customer service for details.

Note

Applicators with Ni 120 RTD types come with a 6-pin rectangular cordset (24W088). See [Parts, page 26](#).

Single

Part	Series	RTD Type	Solenoid Valve
24P073	B	Pt 100 (385)	24 VDC
24P074	B	Pt 100 (385)	110 VAC
24P246	B	Pt 100 (385)	None
24P299	B	Ni 120	24 VDC
24P300	B	Ni 120	110 VAC
24P307	B	Ni 120	None

Slim (Single)

Part	Series	RTD Type	Solenoid Valve
24U021	B	Pt 100 (385)	24 VDC
24U022	B	Pt 100 (385)	110 VAC
24U023	B	Pt 100 (385)	None
24U024	B	Ni 120	24 VDC
24U025	B	Ni 120	110 VAC
24U026	B	Ni 120	None

Dual

Part	Series	RTD Type	Solenoid Valve
24P075	B	Pt 100 (385)	24 VDC
24P076	B	Pt 100 (385)	110 VAC
24P247	B	Pt 100 (385)	None
24P301	B	Ni 120	24 VDC
24P302	B	Ni 120	110 VAC
24P308	B	Ni 120	None

Low Profile - Dual

Part	Series	RTD Type	Solenoid Valve
24U027	B	Pt 100 (385)	24 VDC
24U028	B	Pt 100 (385)	110 VAC
24U029	B	Pt 100 (385)	None
24U030	B	Ni 120	24 VDC
24U031	B	Ni 120	110 VAC
24U032	B	Ni 120	None

Quad

Part	Series	Module Spacing Type*	RTD Type	Solenoid Valve
24P077	B	I	Pt 100 (385)	24 VDC
24P078	B	I	Pt 100 (385)	110 VAC
24P079	B	II	Pt 100 (385)	24 VDC
24P080	B	II	Pt 100 (385)	110 VAC
24P250	B	I	Pt 100 (385)	None
24P254	B	II	Pt 100 (385)	None
24P303	B	I	Ni 120	24 VDC
24P304	B	I	Ni 120	110 VAC
24P305	B	II	Ni 120	24 VDC
24P306	B	II	Ni 120	110 VAC
24P309	B	I	Ni 120	None
24P310	B	II	Ni 120	None

* See [Dimensions, page 46](#).

Low Profile - Quad

Part	Series	RTD Type	Solenoid Valve
24U033	B	Pt 100 (385)	24 VDC
24U034	B	Pt 100 (385)	110 VAC
24U035	B	Pt 100 (385)	None
24U036	B	Ni 120	24 VDC
24U037	B	Ni 120	110 VAC
24U038	B	Ni 120	None

Component Identification

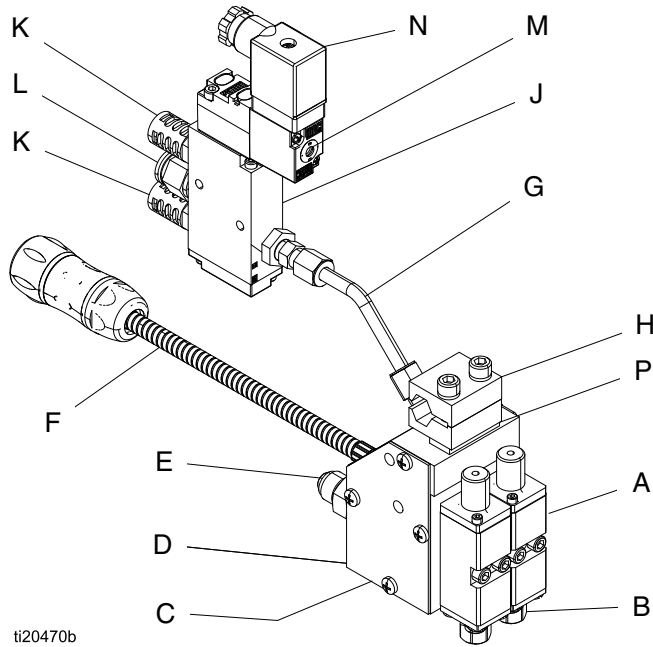

- A Dispense module
- B Fluid outlet/nozzle (3/8–24)
- C Fluid filter (not visible)
- D Manifold
- E Fluid inlet (9/16–18, —6 JIC, 37° flare)
- F Cordset (24W087 shown)
- G Air tube
- H Mounting clamp (1/2 in. diameter bar)
- J Solenoid valve (24 VDC, 110 VAC); not included with all models
- K Muffer
- L Air inlet (3/8 in. diameter tubing)
- M Manual override switch
- N Solenoid valve electrical connector
- P Insulator

ti20470b

Figure 1 24P075 Shown

Overview

The valve uses the air-opened, spring closed mode of operation. It uses a three-way exhausting solenoid to control the piston inside the dispense module. Fluid is filtered through the manifold filter (C) before entering the dispense module fluid inlet port. Then the fluid is filtered one final time through the module filter (P), which is located in each module, directly before the ball and seat.

When air moves the piston rod and ball from its seat, it opens the fluid outlet. When the air shuts off, the spring pushes the piston rod and ball into its seat and closes the fluid outlet.

The gun should be rigidly mounted and remotely operated by a melter system and triggering device. The melter system provides pressurized fluid to the valve. The triggering device controls the fluid flow by opening and closing the solenoid valve.

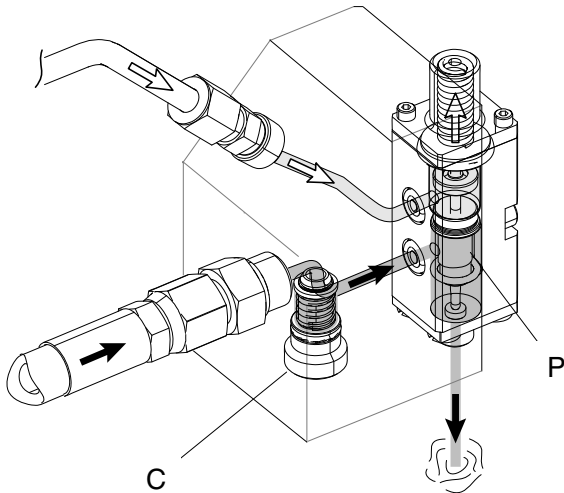

Figure 2 Air and Fluid Flow



Grounding

<p>The equipment must be grounded to reduce the risk of static sparking. Static sparking can cause fumes to ignite or explode. Grounding provides an escape wire for the electric current.</p>					

- **Pump:** follow manufacturer's recommendations.
- **Dispense applicator:** grounded through electrical connection.
- **Air compressor:** follow manufacturer's recommendations.
- **Fluid supply container:** follow local code.
- **Solvent pails used when flushing:** follow local code. Use only conductive metal pails, placed on a grounded surface. Do not place the pail on a nonconductive surface, such as paper or cardboard, which interrupts grounding continuity.
- **To maintain grounding continuity when flushing or relieving pressure:** ensure mounting manifold and electrical power connector are grounded properly.

Installation

Mounting

NOTICE

To prevent heat transferring into other components of the packaging line, ensure that the insulator (P) is installed.

Low Profile Models: Use a 3/4 in. (19 mm) wrench to adjust nuts that control position of gun assembly on threaded rod.

All Other Models: See the following instructions. Mount manifold on a 1/2 in. (12 mm) diameter bar using mounting clamp (H) to hold the gun assembly in place and ensure adhesive is applied properly.

1. Use a 5 mm Allen wrench to loosen the mounting clamp and slide the gun assembly on the mounting bar.
2. Tighten the mounting clamp.

Note

Provide enough room to access sides of applicator for maintenance and repair.

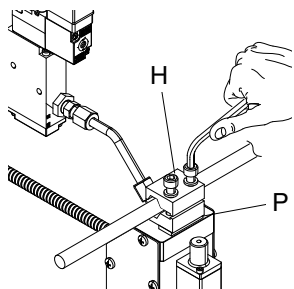

Figure 3 Mounting Clamp

Connect Heated Hose

1. Connect the hose fluid outlet to the manifold fluid inlet (E). Use two 11/16 in. wrenches to tighten the hose fitting.

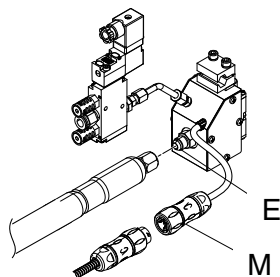

Figure 4 Connect the Heated Hose

2. Connect the cordset (M) to the hose.
3. Connect the hose inlet to the melter system outlet. See the heated hose manual for installation guidelines.
4. Connect the hose cordset to melter. See the heated hose manual for installation guidelines.

Connect Solenoid Valve

1. Connect 3/8 in. diameter air supply tubing to a clean, dry, and non-lubricated air supply and to the push-to-connect air inlet fitting (L).

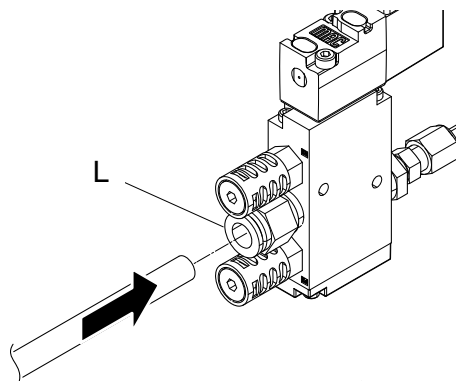

Figure 5 Air Inlet Fitting



2. Connect solenoid valve to 24 VDC or 110 VAC signal. See [Connect Triggering Device, page 10](#).

For applicators without a supplied solenoid valve:

- Use solenoid valves with an override switch.
- Ensure that your solenoid valve is connected to the manifold with tubing rated for 400°F(204°C).
- Ensure the solenoid valve is rated for high-temperature applications.

Connect Triggering Device

Identify if your model uses a 24 VDC or 110 VAC solenoid valve. Connect solenoid valve to 24 VDC or 110 VAC signal.

					
<p>Improper electrical connection can result in electric shock. All electrical wiring must be done by a qualified electrician and comply with all local codes and regulations.</p>					

1. Loosen the mounting screw and disconnect the electrical connector (N) from the solenoid valve (J). Set the gasket and screw aside.

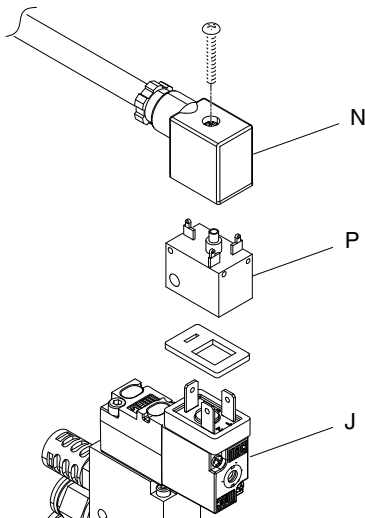
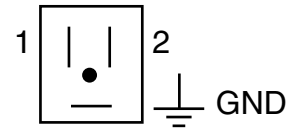

Figure 6 Solenoid Valve Electrical Connector

2. Insert a small screwdriver where the mounting screw was removed and gently press the electrical connector (P) out of the electrical connector housing (N).
3. Thread a three-conductor cable through the strain relief. Connect the positive and negative wires to terminals 1 and 2 on the electrical connector (P). Connect the ground wire to the ground terminal.

Note

It does not matter which terminal the positive and negative wires are connected to.



Solenoid Valve Connector

Figure 7

4. Reassemble the electrical connector (P) and housing (N). Retighten strain relief.
5. Place the gasket on the housing and connect the electrical connector into the solenoid valve (J) with the mounting screw. See [Fig. 6](#).

Prime Before Using Equipment

The equipment was tested with oil, which is left in the fluid passages to protect parts. Prime the equipment with hot melt until all of the oil is pushed out before using the equipment. See [Flush, page 11](#).

Flush

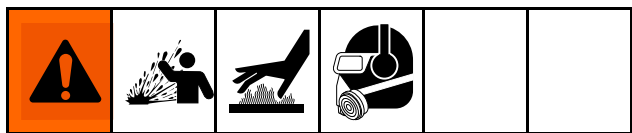

1. Disconnect or turn off the device which triggers the solenoid valve.
2. Heat the system to working temperature.
3. Place waste container under the gun to catch the adhesive.
4. Ensure the nozzle is removed.
5. Press the manual override switch (S) to manually trigger the solenoid valve.
6. Dispense hot melt (adhesive) until it is clean.

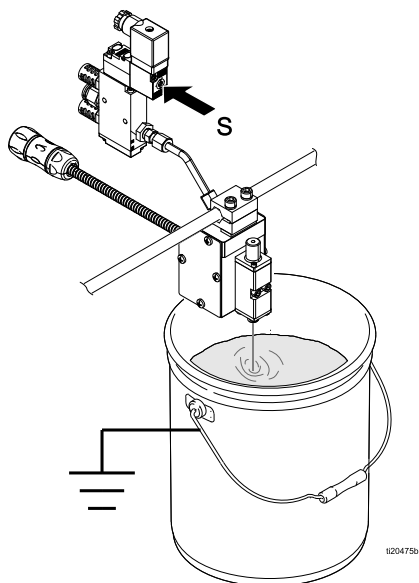
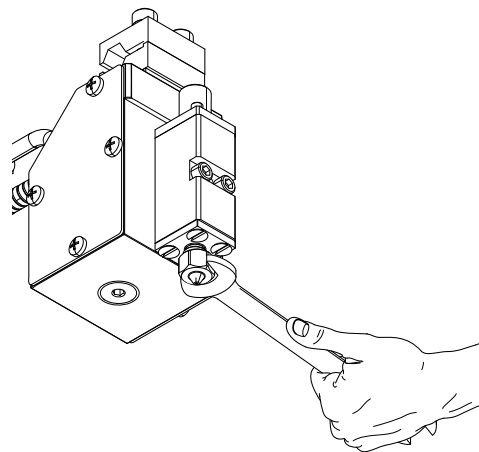

Figure 8

Install Nozzle

Use 1/2 in. wrench to install nozzle. See [Kits and Accessories, page 44](#).



Select RTD

Note

For InvisiPac systems only.

Identify RTD type used in applicator on the system Advanced Display Module (ADM). The RTD type is listed on the manifold cover plate. See the InvisiPac system manual for instructions to configure this setting.

NOTICE

An incorrect RTD setting will cause the system to be incapable of maintaining the temperature setting. The applicator may overheat and trip the thermal cutoff, if the applicator uses a PT 100 (385) and NI 120 is selected on the ADM Setup screen. The applicator may under-heat if the applicator uses a NI 120 and PT 100 (385) is selected on the ADM Setup screen.

- If PT 100 (385) is listed, select PT 100 (385) in the ADM Setup screens.
- If NI 120 is listed, select NI 120 in the ADM Setup screens.

Operation

Pressure Relief Procedure



Follow the Pressure Relief Procedure whenever you see this symbol.

<p>This equipment stays pressurized until pressure is manually relieved. To help prevent serious injury from pressurized fluid, such as skin injection, and splashing fluid, follow the Pressure Relief Procedure when you stop spraying and before cleaning, checking, or servicing the equipment.</p>					

1. Depressurize system.
2. Close the bleed-type master air valve.
3. Actuate the applicator repeatedly until no fluid flows.

<p>Material inside the module and hose may still be near setpoint temperature. Wear protective clothing to avoid severe burns.</p>				

4. If you suspect the module nozzle is clogged, remove nozzle and then actuate the module to relieve pressure.
5. If you suspect the module or fluid hose is clogged or that pressure has not been fully relieved after following the steps above, VERY SLOWLY loosen inlet fitting, inlet filter, or hose end coupling to relieve pressure gradually, then loosen completely. Clear hose or module obstruction.
6. Turn off air pressure to the solenoid valve.

Maintenance

Material inside the applicator can be near setpoint temperature. Wear protective clothing to avoid severe burns.					

Daily:

Clean hot melt from exterior of gun.

Weekly:

Inspect the applicator, fluid lines, cordset, and solenoid cable for wear or damage. See [Repair, page 19](#) for instructions.

Replace Inlet Filter

NOTICE					
Remove the filter when the gun is hot. If the gun is cold, the adhesive will be hard and the filter may be difficult to remove or damaged.					

1. Disable gun assembly. See [Before Beginning Repair, page 19](#).

Material inside the applicator can be near setpoint temperature. Wear protective clothing to avoid severe burns.					

2. Remove dirty filter (16) from manifold (1).

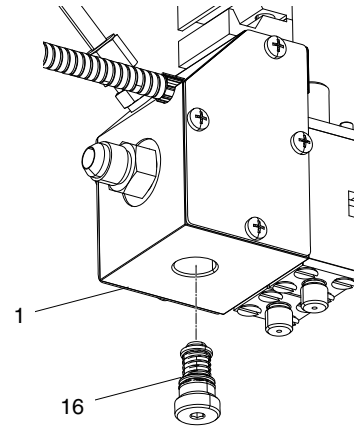

Figure 9 Inlet Filter

3. Apply a thin coating of high-temperature lubricant to seals on the new filter (16) and install in the manifold (1). Torque to 30 in.-lbs (3.4 N•m), using a 5/32 in. (4 mm) Allen wrench.

Filter Maintenance Guidelines

These recommendations are service level guidelines - actual service levels required in your factory will vary based on environmental and operating conditions. High or low volume adhesive usage, as well as adhesives that contain a powered release agent or are otherwise dusty, will have an impact on the frequency of filter maintenance. To establish a preventative maintenance cycle tailored to your environment, Graco recommends inspecting filters every 4 weeks after installation and replacing when necessary. Document replacement intervals and use this as your preventative maintenance schedule moving forward.

	Environment Classification		
	Clean	Moderate	Dusty
Gun manifold filter	Replace filter every six months	Replace filter every four months	Replace filter every two months
Solenoid exhaust filters			

Troubleshooting

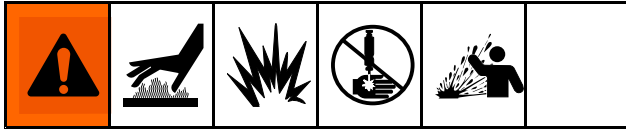

Problem	Cause	Solution
No adhesive or incorrect amount of adhesive out of all modules when triggered	Debris in manifold filter	Replace manifold filter. See Replace Inlet Filter, page 13 .
	Clogged hose	Clean or replace hose.
	Failed solenoid valve	Check for correct operation. Clean or replace.
	No signal to solenoid valve	Check solenoid valve for correct operation.
	Incorrect solenoid valve wiring	Check solenoid valve wiring.
	Incorrect signal to solenoid valve	Check if 24 VDC or 120 VAC.
	Solenoid muffler plugged	Check and replace mufflers.
	No fluid pressure	Check adhesive delivery system.
	Heater failure (cold gun)	Check and replace heater cartridges. See Replace Heater Cartridge, page 20 .
	No air to solenoid valve	Check air supply.
	Dirty or faulty triggering device	Check, clean, or replace triggering device.
	Solenoid valve connected incorrectly	Check solenoid valve air connections.
No adhesive or incorrect amount of adhesive out of one/some modules when triggered	Clogged manifold passage	Clean or replace manifold.
	Debris in nozzle	Clean or replace nozzle.
	Failed module in closed position	Check for correct operation. Clean or replace. See Check Module, page 16 .
	Debris in module filter	Replace module. See Replace Module, page 24 .
Adhesive out of one/some modules when not triggered	Clogged manifold passage	Clean or replace manifold.
	Failed module in open position	Clean or replace module. See Replace Module, page 24 .
	Adhesive pressure too high	Check and reduce fluid pressure.

Problem	Cause	Solution
Gun will not heat	Heater failure	Check and replace heater cartridge. See Replace Heater Cartridge, page 20 .
	Loose cord set connection	Check connection.
	RTD failure	Check and replace RTD. See Check RTD, page 17 .
	Incorrect RTD for adhesive delivery system	Check delivery system RTD requirement
	Thermal cutoff failure	Check and replace thermal cutoff. See Replace Thermal Cutoff, page 20 .
	Wrong RTD type selected	Check RTD type settings on the system. Change if necessary. See Select RTD, page 11 .
Gun overheats	Heater failure	Check and replace heater cartridge. See Replace Heater Cartridge, page 20 .
	RTD failure	Check and replace RTD. See Check RTD, page 17 .
	Incorrect RTD for adhesive delivery system	Check delivery system RTD requirement.
	Incorrect power to heater	Check and correct power.
	Wrong RTD type selected	Check RTD type settings on the system. Change if necessary. See Select RTD, page 11 .
Gun under-heats	Heater failure	Check and replace heater cartridge. See Replace Heater Cartridge, page 20
	RTD failure	Check and replace RTD.
	Incorrect RTD for adhesive delivery system	Check delivery system RTD requirement.
	Incorrect power to heater	Check and correct power.
	Wrong RTD type selected	Check RTD type settings on the system. Change if necessary. See Select RTD, page 11 .
Adhesive leaking from gun	Module o-ring failure	Check and replace o-ring. See Replace Module, page 24 .
	Inlet fitting loose	Tighten fitting.
	Manifold filter o-ring failure	Check and replace o-ring.
	Nozzle loose	Tighten nozzle.
	Module seal failure	Check and replace module. See Check Module, page 16 .

Problem	Cause	Solution
Adhesive out of all modules when not triggered	Solenoid valve failure	Check and replace solenoid valve.
	Adhesive pressure too high	Check and reduce fluid pressure.
	Solenoid valve connected incorrectly	Check solenoid valve air connections.
	Module failure	Check and replace all modules. See Check Module, page 16 .

Check Module

Check the module operation to verify if the module has failed and needs to be replaced.

1. Insert a small Allen wrench into the top of the module.
2. Press the solenoid valve override switch (S) to manually trigger the gun.

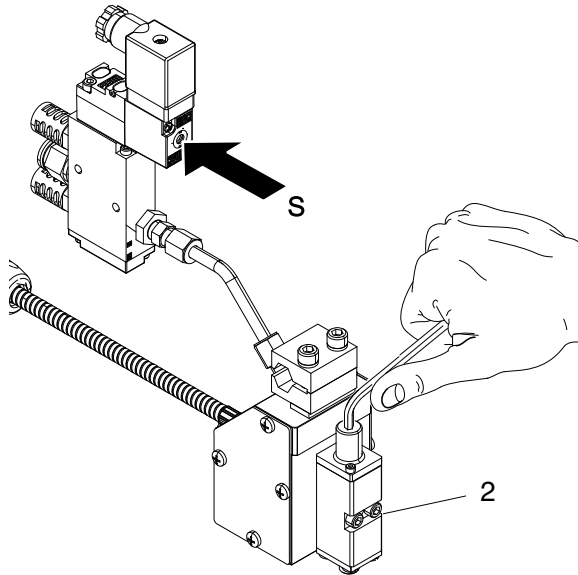

Figure 10 Check Module

If the wrench moves up and down, then the module is operating properly

If the wrench does not move, then the module needs to be replaced. See [Replace Module, page 24](#).

Check Nozzle and Module

Trigger the gun without the nozzle to determine if the nozzle or module is clogged.

1. Disable gun assembly. See [Before Beginning Repair, page 19](#).
2. Use a 1/2 in. wrench to remove the nozzle.

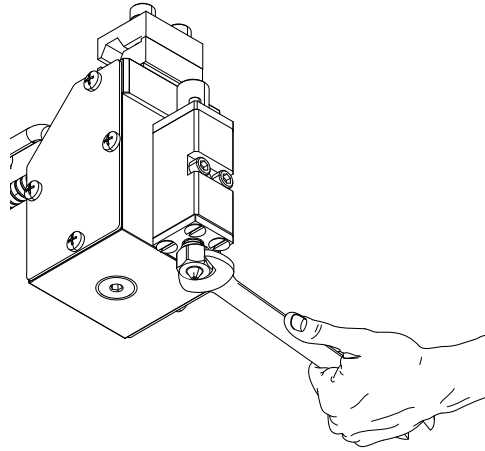

Figure 11

3. Connect the power and solenoid cable.
4. Return the gun back into operation.
5. Trigger the gun.
 - a. If adhesive flows, clean the nozzle and reinstall on the module.
 - b. If adhesive does not flow, the module is clogged and needs to be replaced. See [Replace Module, page 24](#).

Check Heater

Check the continuity of the heater to verify proper resistance. If there is no continuity, the heater may have failed and need to be replaced. See [Wiring Diagram, page 21](#), and parts illustrations.

1. Disable gun assembly. See [Before Beginning Repair, page 19](#).
2. Check resistance of the heater using a multimeter between the pins of the cordset connector. See connectors illustrations in cordset pin tables.
 - If there is no continuity measure resistance of the heater at the butt splice terminals (52b).
 - If the resistance is outside the range listed below replace the heater cartridge. See [Replace Heater Cartridge, page 20](#).

Cordset	Check Pins	Gun Model	Resistance Values
24W087, Pt 100 (385) RTD Cordset	A and C	24U021–24U026 24U027–24U032	260–280 ohms
		All other models	130–140 ohms
24W088, Ni 120 RTD Cordset	1 and 2	24U021–24U026 24U027–24U032	260–280 ohms
		All other models	130–140 ohms

Table 1 24W087, Pt 100 (385) RTD Cordset

Pin	Description	
A	Thermal Cutoff	
B	Ground	
C	Heat -	
D	RTD (White)	
E	RTD (Red)	

Table 2 24W088, Ni 120 RTD Cordset

Pin	Description	
1	Thermal Cutoff	
2	Heat -	
3	RTD (White)	
5	RTD (Red)	
G	Ground	

Check RTD

Check the continuity of the RTD to verify proper resistance. If there is no continuity, the RTD has failed and needs to be replaced.

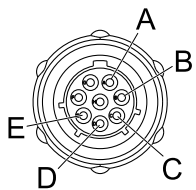
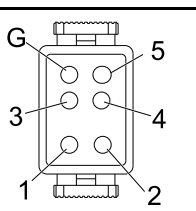
1. Disable gun assembly. See [Before Beginning Repair, page 19](#).
2. Check resistance of the RTD using a multimeter between the pins of the cordset connector. See connectors illustrations in cordset pin tables.

Cordset	Check Pins	Resistance Values At Room Temperature 70–72°F (21–22°C)
24W087, Pt 100 (385) RTD Cordset	D and E	107-115 ohms
24W088, Ni 120 RTD Cordset	3 and 5	130-140 ohms

3. Replace the RTD if the resistance reading is outside the range, or if there is no continuity. See [Replace RTD, page 20](#).

Check Thermal Cutoff

If working properly, the cutoff will trip at 450°F (232°C) and resets at 370°F (187°C). If failure is suspected, allow gun to cool and then check the continuity of the thermal cutoff to verify it has not failed. If there is no continuity, the cutoff has failed and needs to be replaced.

1. Disable gun assembly. See [Before Beginning Repair, page 19](#).
2. Remove cover plate.
3. Check for continuity using a multimeter between pin of cordset connector and the wires from the thermal cutoff that connects to the heater lead.

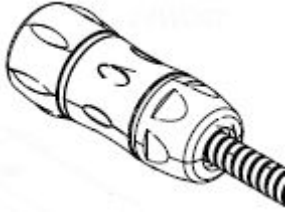
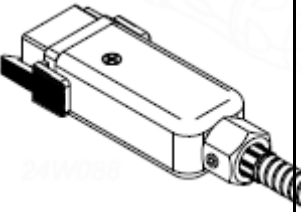
Cordset	Check Pins
24W087, Pt 100 (385) RTD Cordset 	A
24W088, Ni 120 RTD Cordset 	1

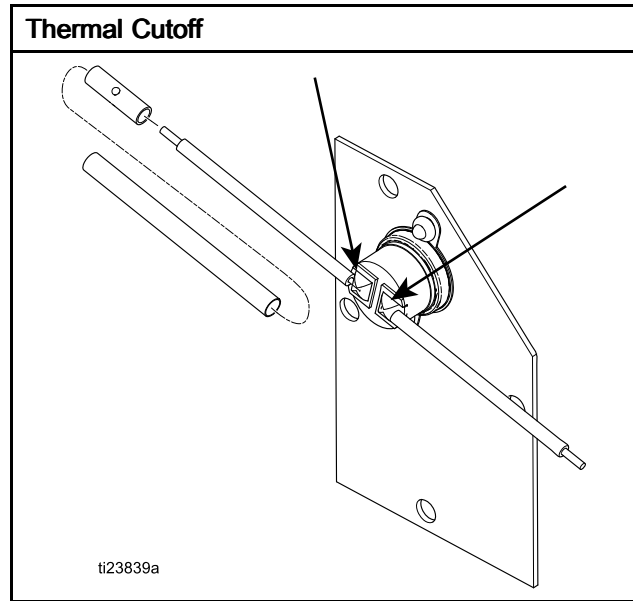

Repair

Required Tools

- Phillips screw driver
- Flat blade screw driver
- 5/64 in (2 mm) and 5/32 in. (4 mm) Allen wrenches
- 1/2 in. and 7/16 in. wrenches
- Torque wrench
- Waste container
- High-temperature anaerobic thread sealant (110110)
- High-temperature lubricant (24T156)
- Anti-sieze (24T179)
- Crimp tool (24W086)

Before Beginning Repair

1. Turn off the melter system. See melter manual for shutdown instructions.
2. Relieve pressure. See [Pressure Relief Procedure, page 12.](#)
3. Disconnect the cordset from the heated hose.

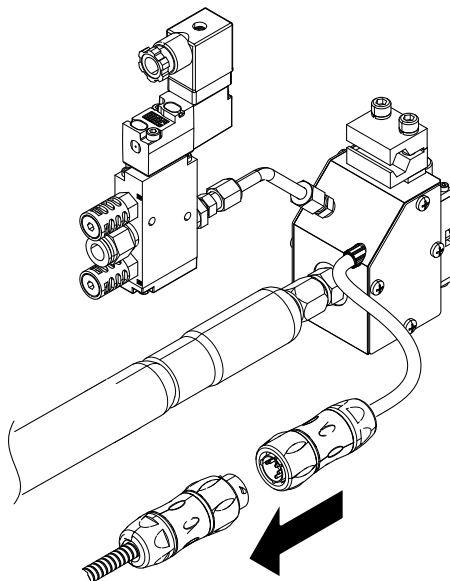

Figure 12 Disconnect Cordset

4. Loosen the mounting screw and disconnect the solenoid valve power connector (N) from the solenoid valve (J).

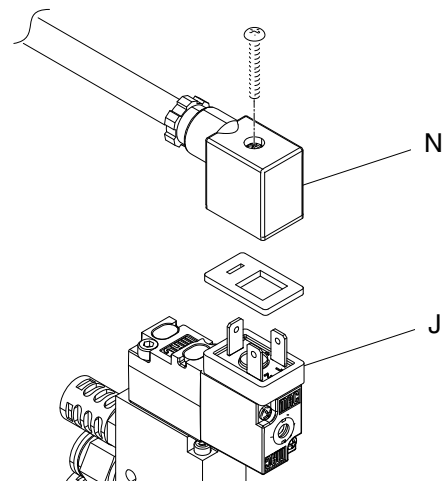

Figure 13 Disconnect Solenoid Valve Power Connector

Replace Heater Cartridge

1. Disable gun assembly.
2. Use a Phillips screwdriver to remove screws (15) and manifold cover plate (52).
3. Remove the heater cartridges (3) from the manifold (1).

Note

Note the placement of the heaters and lead lengths.

Note

On guns that are not low profile, if the heater cartridge does not easily pull out, remove the other cover plate (18) and press out with a small screwdriver.

4. Remove butt splices(52b) from heater wires (3), thermal cutoff (52a), and cordset wire leads (17).
5. Recrimp new heater wires into new splices (52b). See wiring diagram.

NOTICE
To prevent a short to ground and blowing a MZLP fuse, ensure bare wires are covered with fiberglass tape and sleeves (52c) are centered over splices (52b).

6. Insert the new heater cartridges (3) into the manifold (1), placing the heater with the shorter leads closer to the wiring port.

Note

Do not apply thermal grease to the heater cartridge.

7. Reinstall the manifold cover plate (52).
8. Reconnect the cordset (17) to the heated hose.
9. Reconnect the solenoid valve power connector to the solenoid valve (9).

Replace RTD

The RTD is replaced by replacing the entire cordset. See [Replace Cordset, page 22](#), for instructions.

Replace Thermal Cutoff

1. Disable gun assembly.

2. Use a Phillips screws driver to remove the four screws (15) and manifold cover plate (52).
3. Remove splices from heater wires (3) and cordset wire leads (17).
4. Crimp wires. See [Wiring Diagram, page 21](#).

NOTICE
To prevent a short to ground and blowing a MZLP fuse, ensure bare wires are covered with fiberglass tape and sleeves (52c) are centered over splices (52b).

- a. Slide sleeves (52c) over each pair of wires before crimping.
 - b. Crimp butt splice (52b) on cordset heater wires (17) and heater wires (3). Light pull on splice to ensure it is crimped.
 - c. Crimp white wire to one thermal cutoff lead (52a).
 - d. Crimp other thermal cutoff lead (52a) to one heater wire(s) (3).
 - e. Crimp other heater wire(s) to black lead (17).
 - f. Wrap a short piece of fiberglass tape around each splice (52b).
 - g. Center sleeves (52c) over each taped splice (52b).
5. Gently press wires into the manifold. Install plate (52) and screws (15).

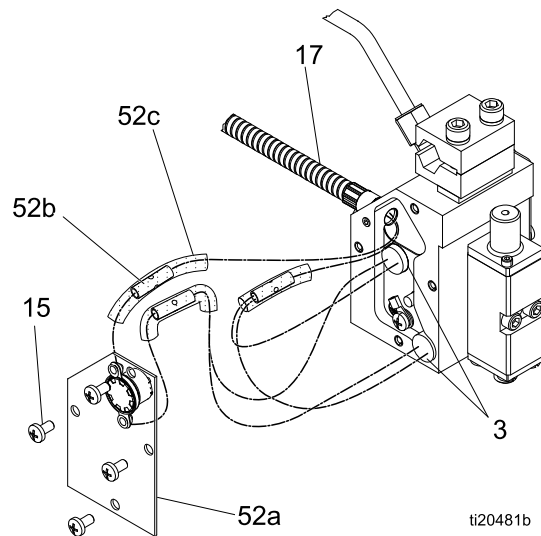

Wiring Diagram Thermal Cutoff

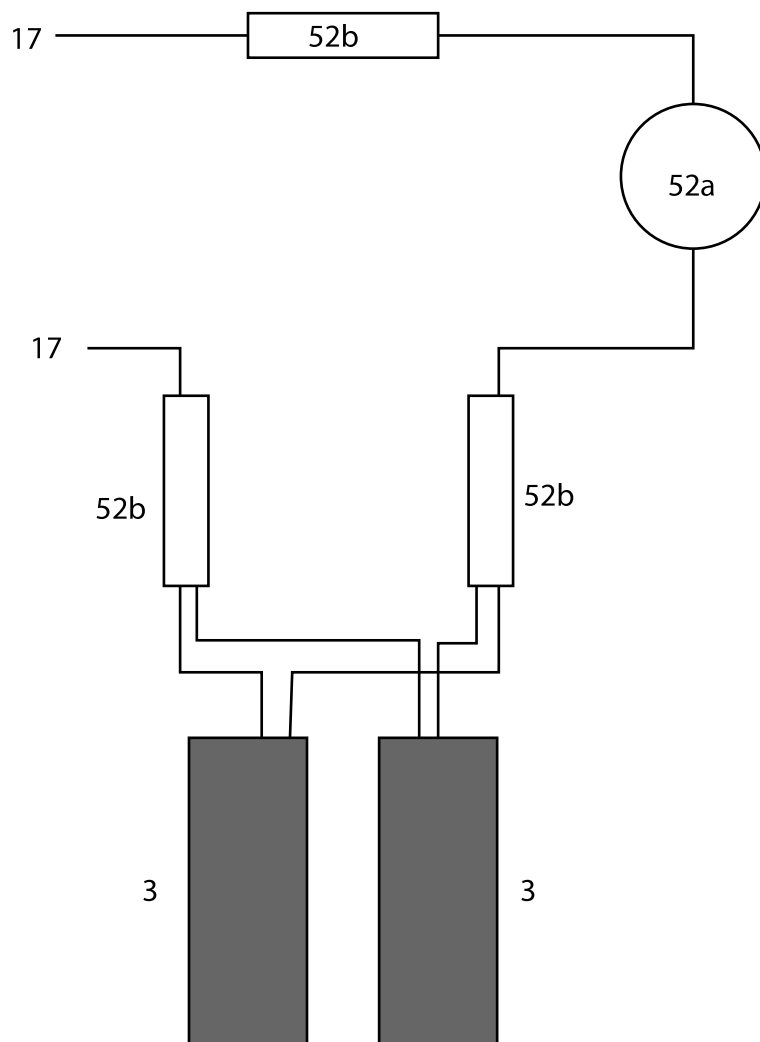

Note

Slim (24U021–24U026) and Low Profile Dual (24U026–24U032) applicators use one heater (3).

Replace Cordset

See [Fig 14](#).

Note

There are two types of cordsets (17): 24W087 is for PT100 (385) RTD controlled guns and 24W088 is for NI 120 Ohm RTD controlled guns. Ensure you have the correct cordset before replacing. See [Parts, page 26](#).

1. Disable gun assembly. See [Before Beginning Repair, page 19](#).
2. Use a Phillips screwdriver to remove the four screws (15) and manifold cover plate (52).
3. Use a 2 mm Allen wrench to remove the set screw (8) holding the cordset (17) on the manifold (1).
4. Use a Phillips screwdriver to remove the ground screw (15) and star washer (20) from the manifold (1).

5. Remove the RTD (R) from the manifold (1).

Note

On guns that are not low profile, if the RTD does not easily pull out, remove the other cover plate (19) and press out with a small screwdriver.

6. Disconnect thermal cutoff (52).
7. Remove the cordset (17) from the manifold (1).
8. Install the new cordset, RTD, and ground (17 in the manifold (1). Recrimp thermal cutoff wires. See [Wiring Diagram, page 21](#), for connections.

Note

Ensure the cordset bushing is fully inserted into the manifold.

9. Install set screw (8) against the cordset bushing to secure the cordset (17) to the manifold (1).

10. Reinstall the ground lead onto the manifold (1).

Note

Ensure the star washer (20) is placed below the ground ring terminal.

11. Insert the plug (P), RTD (R) and thermal cutoff (52) into the manifold ports. See Fig 14.

Note

Do not apply grease on the RTD or thermal cutoff.

12. Insert the heater cartridges (3) in the manifold (1).

NOTICE

To prevent removing wire insulation or disconnecting wires, do not pinch any wires when inserting wire in the manifold. If wire insulation is removed, the RTD or heaters could short out and need to be replaced.

13. Reinstall the manifold cover plate (52).

14. Reconnect the cordset (17) to the heated hose.

15. Return to service.

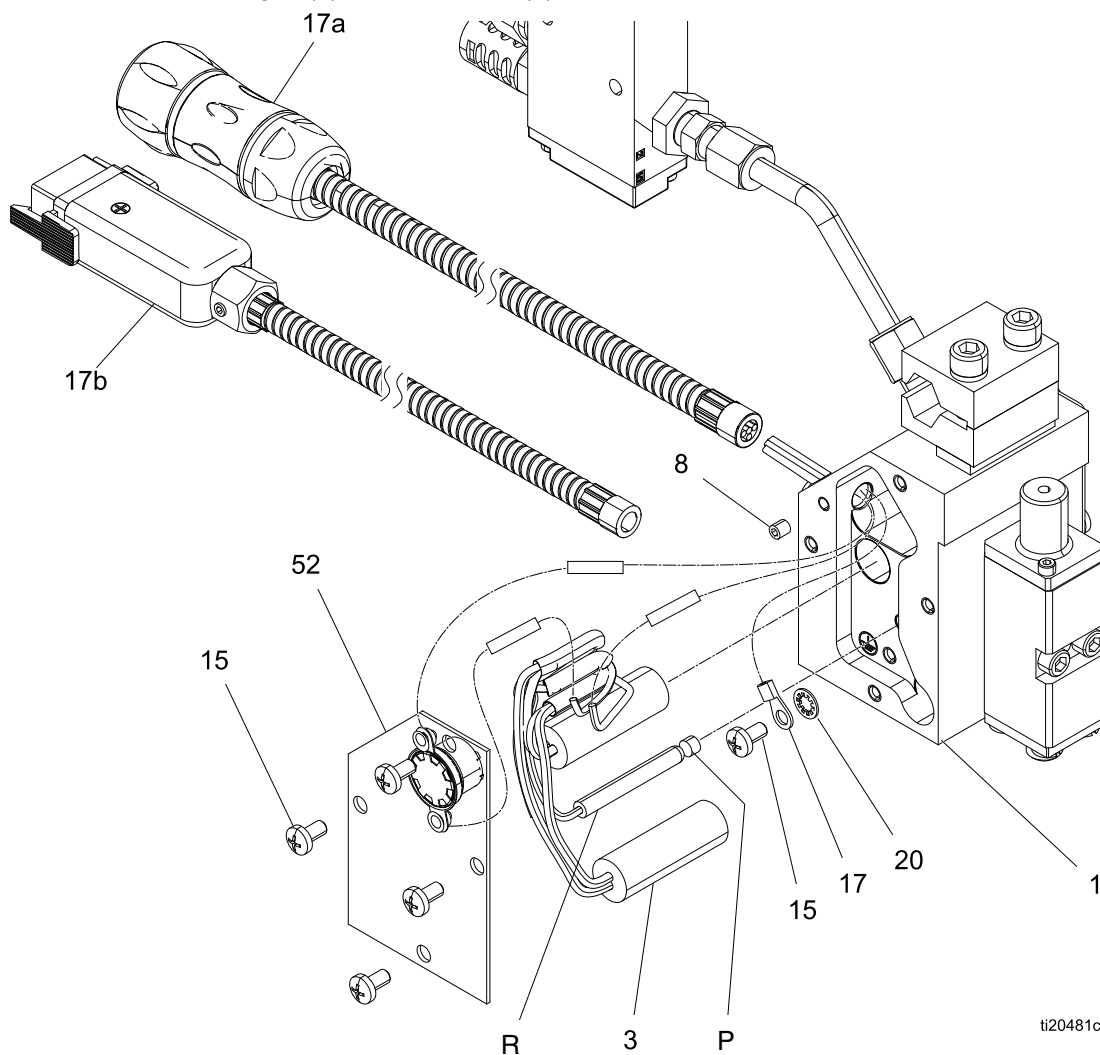

Figure 14 Repair Parts

NOTE: See Slim and Low Profile GS35 subsections of the Parts chapter ([Parts](#), page 26).

Replace Solenoid Valve

1. Disable gun assembly. See [Before Beginning Repair, page 19](#).
2. Remove solenoid valve fitting (102) and solenoid valve (9) from tube (7).
3. Use a 1/2 in. and 7/16 in. wrench to tighten new connector (102) to tube (7).

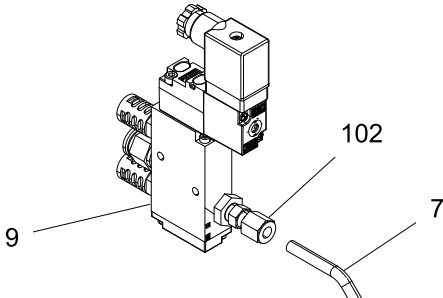
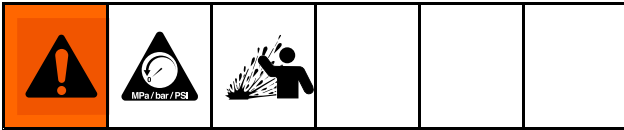
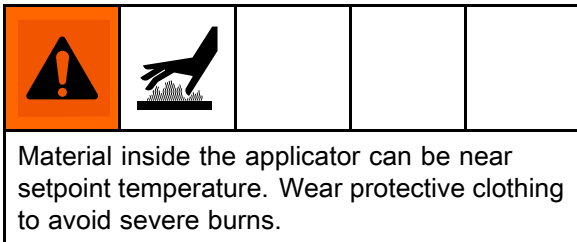

Figure 15 Replace Solenoid Valve

Replace Module



1. Disable gun assembly. See [Before Beginning Repair, page 19](#).



2. Use a 5/32 in. (4 mm) Allen wrench to remove the two mounting screws (22) and module (2) from manifold (1).

NOTICE

Do not allow adhesive to enter the air ports, to allow air to flow through valve. Adhesive in the air ports will obstruct the flow of air and damage the valve.

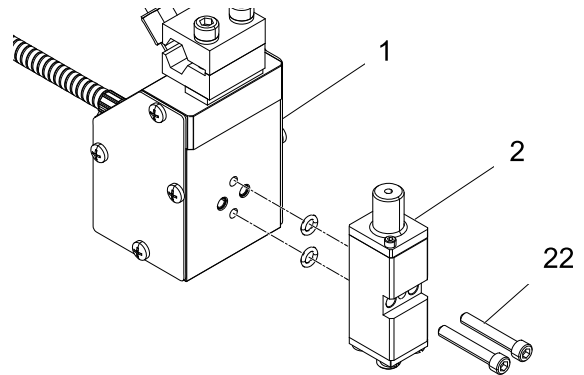
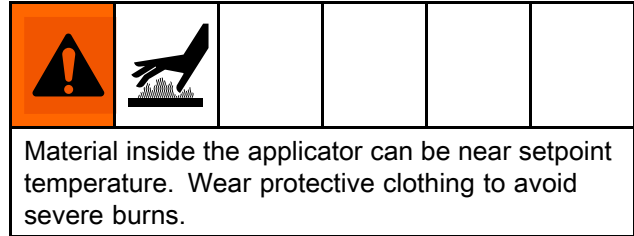

Figure 16 Remove Module From Manifold

3. Apply high temperature lubricant to o-rings in module (2).
4. Apply anti-seize to two screw threads (22). Use a 5/32 in. (4 mm) Allen wrench to install new module (2) on manifold with two screws (22). Torque to 28–32 in.-lbs (3.2–3.6 N•m).
5. Connect cordset (17) to the heated hose.

Replace Applicator



1. Disable gun assembly. See [Before Beginning Repair, page 19](#).
2. Loosen the mounting bar clamp and remove the applicator from the mounting bar.
3. Install new applicator. See [Installation, page 9](#).

Parts

Single GS35

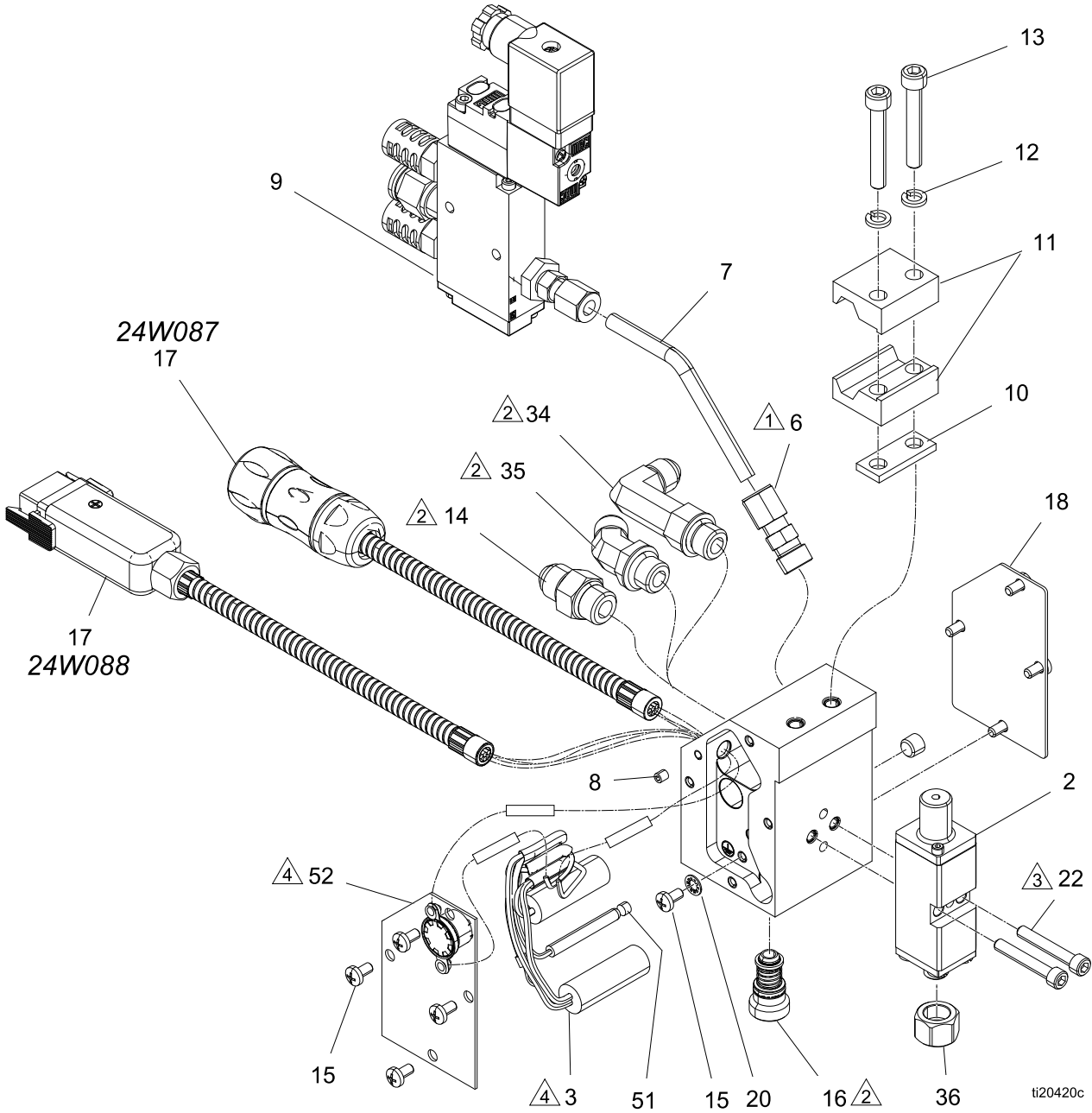

ti20420c





-  Apply thread sealant to threads.
-  Apply a thin coating of lubricant to seals.
-  Apply anti-seize to first 1/2 in. of threads. Torque to 28-32 in-lbs (3.2-3.6 N•m).
-  See [Wiring Diagram, page 21](#).

Table 3 Single GS35

Ref	Part	Description	Quantity					
			24P073	24P074	24P246	24P299	24P300	24P307
1	---	HOUSING, single	1	1	1	1	1	1
2●	---	MODULE, sc, hotmelt	1	2	1	1	2	1
3	24V789	HEATER, 240 VAC, 200W, 1/2 dia. x 1.5 in.	2	2	2	2	2	2
6	100113	CONNECTOR, male	1	1		1	1	
7	24R231	TUBE, applicator, hotmelt, open	1	1		1	1	
8	124736	SCREW, set, cup, M4x.7x4 mm, sst	1	1	1	1	1	1
9*	24P239	VALVE, solenoid, 3w, sr, 24 VDC	1			1		
	24P240	VALVE, solenoid, 3w, sr, 110 VAC		1			1	
10	24P276	INSULATOR, clamp, bar, housing	1	1	1	1	1	1
11	24P277	CLAMP, bar, housing	2	2	2	2	2	2
12	108050	WASHER, lock, spring	2	2	2	2	2	2
13	117030	SCREW, shcs M6 x 40	2	2	2	2	2	2
14	24P615	FITTING, adapter, JIC -6 (37° flare) x SAE -6, mxm, cst	1	1	1	1	1	1
15	128306	SCREW, mach, phil pan hd	9	9	9	9	9	9
16	24P275	FILTER, cartridge, 80 mesh, hotmelt (24P802 - 3 pack)	1	1	1	1	1	1
17a	24W087	CORD SET, 240V, applicator, Pt 100 ohm RTD	1	1	1			
17b	24W088	CORD SET, 240V, hotmelt, Ni 120 ohm RTD				1	1	1
18	---	PLATE, cover, housing, hotmelt	1	1	1	1	1	1
20	157021	WASHER, lock, int	1	1	1	1	1	1
22●	104705	SCREW, cap, sch; #10-32 x 1/25 in.	2	2	2	2	2	2
29▲	16K931	LABEL, safety, warning	1	1	1	1	1	1
34	24P547	FITTING, elbow, JIC -6 (37° flare) x SAE -6, mxm, cst	1	1	1	1	1	1
35	24P548	FITTING, elbow, 45°, JIC -6 (37° flare) x SAE -6, mxm, cst	1	1	1	1	1	1
36■	---	NOZZLE						
51	16Y799	PLUG	1	1	1	1	1	1
52	24V790	KIT, THERMAL CUTOFF(includes 52a-52c)	1	1	1	1	1	1
52a	---	PLATE, with thermal cutoff	1	1	1	1	1	1
52b	---	CONNECTOR, splice, 14-16 AWG, heat resistant	3	3	3	3	3	3
52c	---	SLEEVE, red, 2 in. (50.88 mm) x 0.16 OD	3	3	3	3	3	3

* See [Solenoid Valve Kits, page 45](#).

● Parts included in Module Repair Kit. See [Module Repair Kit, page 44](#).

■ Purchase Separately. See [Nozzles \(Single Orifice\), page 45](#).

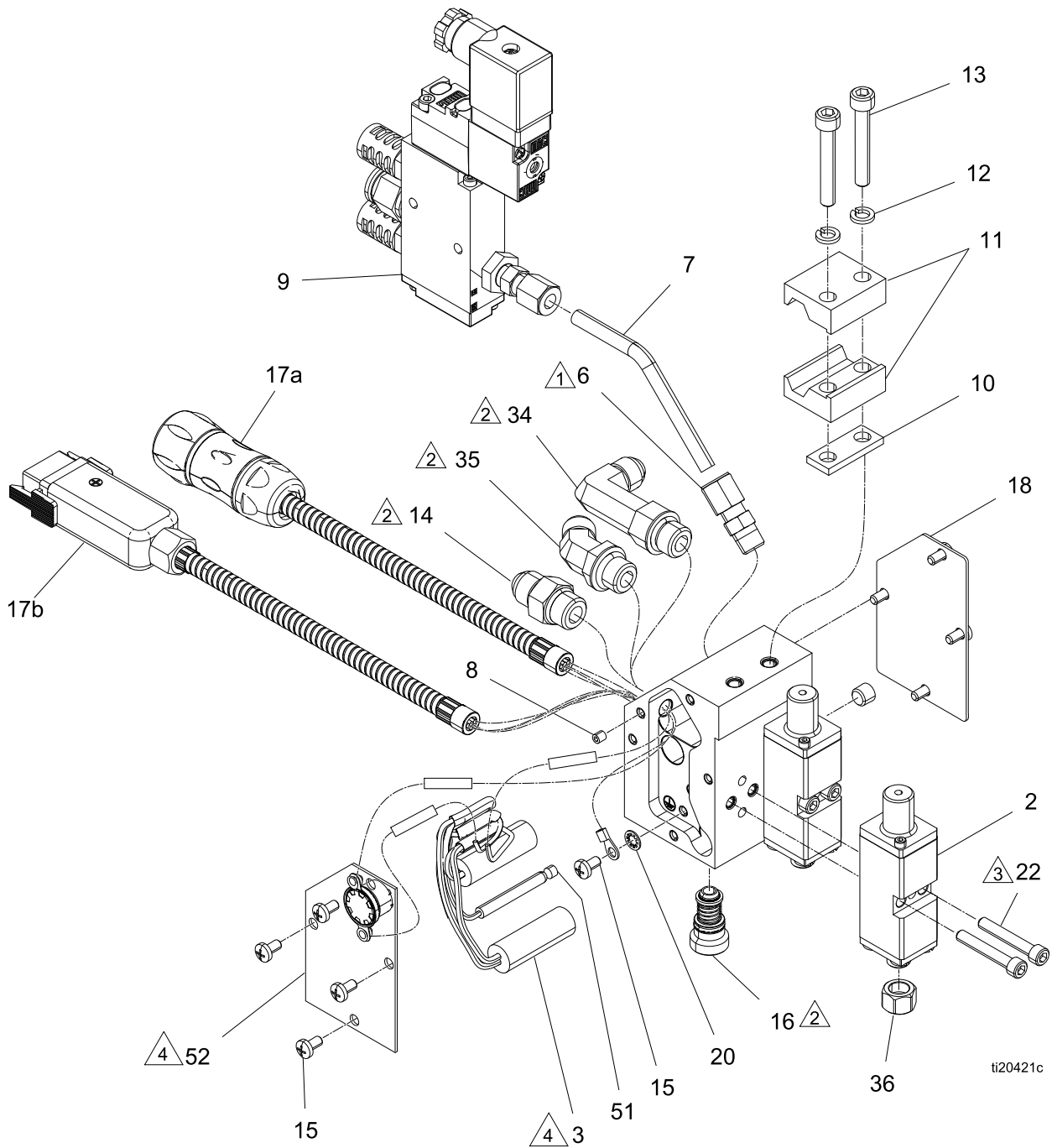

▲ Replacement Warning labels, signs, tags, and cards are available at no cost.

DUAL GS35



ti20421c

-  Apply thread sealant to threads.

 Apply a thin coating of lubricant to seals.
-  Apply anti-seize to first 1/2 in. of threads. Torque to 28-32 in-lbs (3.2-3.6 N•m).

 See [Wiring Diagram, page 21](#).

Table 4 Dual GS35

Ref	Part	Description						
			24P075	24P076	24P247	24P301	24P302	24P308
1	---	HOUSING, dual	1	1	1	1	1	1
2●	---	MODULE, sc, hotmelt	2	2	2	2	2	2
3	24V789	HEATER, 240 VAC, 200W, 1/2 dia. x 1.5 in.	2	2	2	2	2	2
6	100113	CONNECTOR, male	1	1		1	1	
7	24R231	TUBE, applicator, hotmelt, open	1	1		1	1	
8	124736	SCREW, set, cup, M4 x .7 x 4 mm, sst	1	1	1	1	1	1
9*	24P239	VALVE, solenoid, 3w, sr, 24 VDC	1			1		
	24P240	VALVE, solenoid, 3w, sr, 110 VAC		1			1	
10	24P276	INSULATOR, clamp, bar, housing	1	1	1	1	1	1
11	24P277	CLAMP, bar, housing	2	2	2	2	2	2
12	108050	WASHER, lock, spring	2	2	2	2	2	2
13	117030	SCREW, shcs M6 x 40	2	2	2	2	2	2
14	24P615	FITTING, adapter, JIC -6 (37° flare) x SAE -6, mxm, cst	1	1	1	1	1	1
15	128306	SCREW, mach, phil pan hd	9	9	9	9	9	9
16	24P275	FILTER, cartridge, 80 mesh, hotmelt (24P802 - 3 pack)	1	1	1	1	1	1
17a	24W087	CORD SET, 240V, applicator, Pt 100 ohm RTD	1	1	1			
17b	24W088	CORD SET, 240V, hotmelt, Ni 120 ohm RTD				1	1	1
18	---	PLATE, cover, housing, hotmelt	1	1	1	1	1	1
20	157021	WASHER, lock, int	1	1	1	1	1	1
22●	104705	SCREW, cap, sch; #10-32 x 1/25 in.	4	4	4	4	4	4
29▲	16K931	LABEL, safety, warning	1	1	1	1	1	1
34	24P547	FITTING, elbow, JIC -6 (37° flare) x SAE -6, mxm, cst	1	1	1	1	1	1
35	24P548	FITTING, elbow, 45°, JIC -6 (37° flare) x SAE -6, mxm, cst	1	1	1	1	1	1
36■	---	NOZZLE						
51	16Y799	PLUG	1	1	1	1	1	1
52	24V790	KIT, THERMAL CUTOFF (includes 52a-52c)	1	1	1	1	1	1
52a	---	PLATE, with thermal cutoff	1	1	1	1	1	1
52b	---	CONNECTOR, splice, 14-16 AWG, heat resistant	3	3	3	3	3	3
52c	---	SLEEVE, red, 2 in. (50.88 mm) x 0.16 OD	3	3	3	3	3	3

* See [Solenoid Valve Kits, page 45](#).

● Parts included in Module Repair Kit. See [Module Repair Kit, page 44](#).

■ Purchase Separately. See [Nozzles \(Single Orifice\), page 45](#).

▲ Replacement Warning labels, signs, tags, and cards are available at no cost.

Quad GS35

24P077 Type I Shown

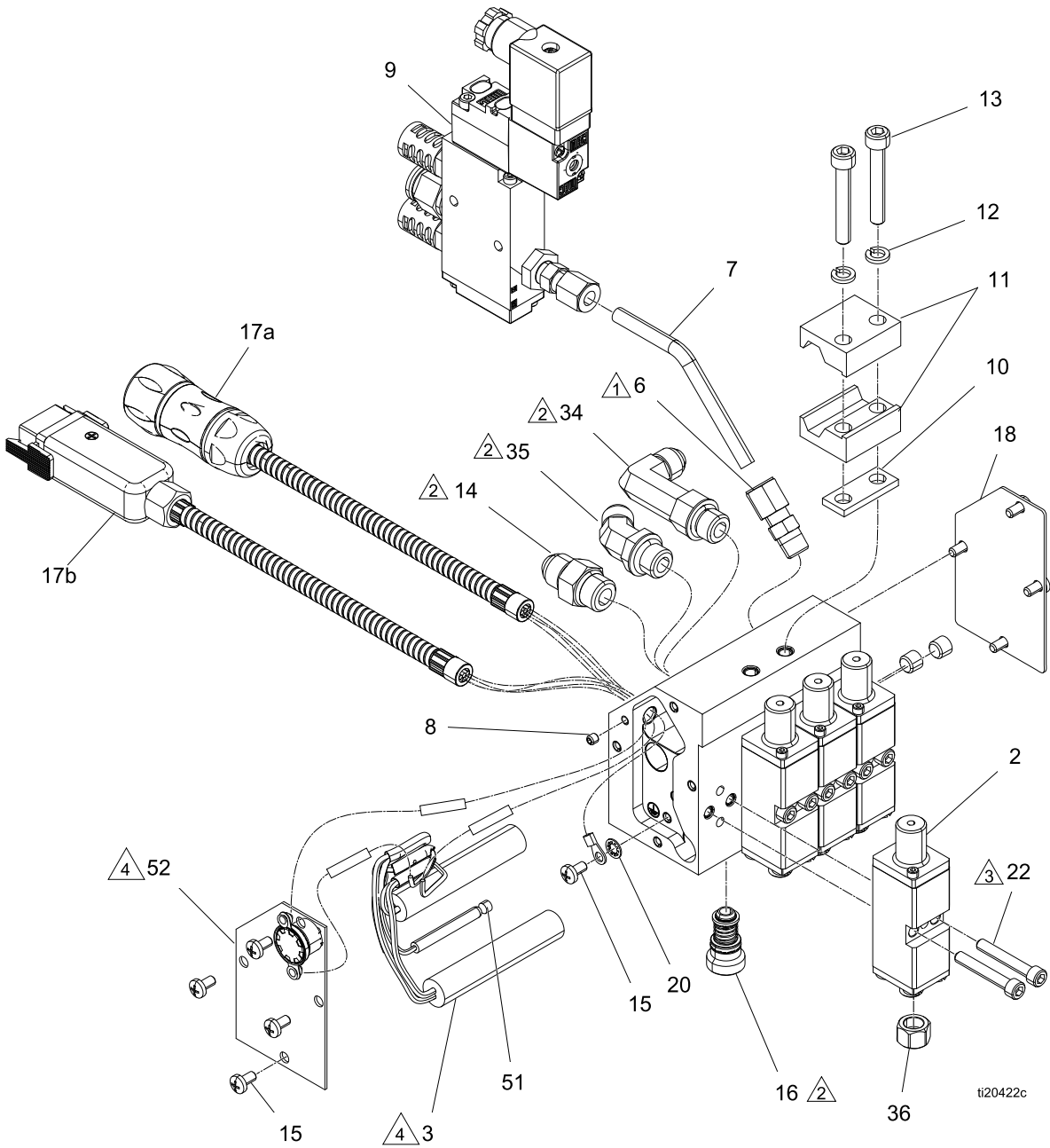

Apply thread sealant to threads.



Apply a thin coating of lubricant to seals.



Apply anti-seize to first 1/2 in. of threads. Torque to 28-32 in-lbs (3.2-3.6 N•m).



See [Wiring Diagram](#), page 21.

Table 5 Quad GS35 With 0.88 in. Spaced Manifold (Type I)

Ref	Part	Description	Quantity					
			24P077	24P078	24P250	24P303	24P304	24P309
1	- - -	HOUSING, 0.88 in.	1	1	1	1	1	1
2●	- - -	MODULE	4	4	4	4	4	4
3	24V791	HEATER, 240 VAC, 200W, 1/2 dia x 2.75 in.	2	2	2	2	2	2
6	100113	CONNECTOR, male	1	1		1	1	
7	24R231	TUBE, applicator, hotmelt, open	1	1		1	1	1
8	124736	SCREW, set, cup, M4 x.7x4 mm, sst	1	1	1	1	1	1
9*	24P239	VALVE, solenoid, 3 way, sr, 24 VDC	1			1		
	24P240	VALVE, solenoid, 3 way, sr, 110 VAC		1			1	
10	24P276	INSULATOR, clamp, bar, housing	1	1	1	1	1	1
11	24P277	CLAMP, bar, housing	2	2	2	2	2	2
12	108050	WASHER, lock, spring	2	2	2	2	2	2
13	117030	SCREW, shcs M6 x 40	2	2	2	2	2	2
14	24P615	FITTING, adapter, JIC -6 (37° flare) x SAE -6, mxm, cst	1	1	1	1	1	1
15	128306	SCREW, mach, phil pan hd	9	9	9	9	9	9
16	24P275	FILTER, cartridge, 80 mesh, hotmelt (24P802 - 3 pack)	1	1	1	1	1	1
17a	24W087	CORD SET, 240V, applicator, Pt 100 ohm RTD	1	1	1			
17b	24W088	CORD SET, 240V, hotmelt, Ni 120 ohm RTD				1	1	1
18	- - -	PLATE, cover, housing, hotmelt	1	1	1	1	1	1
20	157021	WASHER, lock, int	1	1	1	1	1	1
22●	104705	SCREW, cap, sch; #10-32 x 1/25 in.	8	8	8	8	8	8
29▲	16K931	LABEL, safety, warning	1	1	1	1	1	1
34	24P547	FITTING, elbow, JIC -6 (37° flare) x SAE -6, mxm, cst	1	1	1	1	1	1
35	24P548	FITTING, elbow, 45°, JIC -6 (37° flare) x SAE -6, mxm, cst	1	1	1	1	1	1
36■	- - -	NOZZLE						
51	16Y799	PLUG	1	1	1	1	1	1
52	24V790	KIT, THERMAL CUTOFF (includes 52a-52c)	1	1	1	1	1	1
52a	- - -	PLATE, with thermal cutoff	1	1	1	1	1	1
52b	- - -	CONNECTOR, splice, 14-16 AWG, heat resistant	3	3	3	3	3	3
52c	- - -	SLEEVE, red, 2 in. (50.88 mm) x 0.16 OD	3	3	3	3	3	3

* See [Solenoid Valve Kits, page 45](#).

● Parts included in Module Repair Kit. See [Module Repair Kit, page 44](#).

■ Purchase Separately. See [Nozzles \(Single Orifice\), page 45](#).

▲ Replacement Warning labels, signs, tags, and cards are available at no cost.

Parts

Table 6 Quad GS35 with 1.5 in. Spaced Manifold (Type II)

Ref	Part	Description	Quantity					
			24P079	24P080	24P254	24P305	24P306	24P310
1	- - -	HOUSING, 1.5 in.	1	1	1	1	1	1
2●	- - -	MODULE	4	4	4	4	4	4
3	24V791	HEATER, 240 VAC, 200W, 1/2 dia x 2.75 in.	2	2	2	2	2	2
6	100113	CONNECTOR, male	1	1		1	1	
7	24R231	TUBE, applicator, hotmelt, open	1	1		1	1	
8	124736	SCREW, set, cup, m4 x.7x4 mm, sst	1	1	1	1	1	1
9*	24P239	VALVE, solenoid, 3 way, sr, 24 VDC	1			1		
	24P240	VALVE, solenoid, 3 way, sr, 110 VAC		1			1	
10	24P276	INSULATOR, clamp, bar, housing	1	1	1	1	1	1
11	24P277	CLAMP, bar, housing	2	2	2	2	2	2
12	108050	WASHER, lock, spring	2	2	2	2	2	2
13	117030	SCREW, shcs M6 x 40	2	2	2	2	2	2
14	24P615	FITTING, adapter, JIC -6 (37° flare) x SAE -6, mxm, cst	1	1	1	1	1	1
15	128306	SCREW, mach, phil pan hd	9	9	9	9	9	9
16	24P275	FILTER, cartridge, 80 mesh, hotmelt (24P802 - 3 pack)	1	1	1	1	1	1
17a	24W087	CORD SET, 240V, applicator, Pt 100 ohm RTD	1	1	1			
17b	24W088	CORD SET, 240V, hotmelt, Ni 120 ohm RTD				1	1	1
18	- - -	PLATE, cover, housing, hotmelt	1	1	1	1	1	1
20	157021	WASHER, lock, int	1	1	1	1	1	1
22●	104705	SCREW, cap, sch; #10-32 x 1/25 in.	8	8	8	8	8	8
29▲	16K931	LABEL, safety, warning	1	1	1	1	1	1
34	24P547	FITTING, elbow, JIC -6 (37° flare) x SAE -6, mxm, cst	1	1	1	1	1	1
35	24P548	FITTING, elbow, 45°, JIC -6 (37° flare) x SAE -6, mxm, cst	1	1	1	1	1	1
36■		NOZZLE						
51	16Y799	PLUG	1	1	1	1	1	1
52	24V790	KIT, THERMAL CUTOFF (includes 52a-52c)	1	1	1	1	1	1
52a	- - -	PLATE, with thermal cutoff	1	1	1	1	1	1
52b	- - -	CONNECTOR, splice, 14-16 AWG, heat resistant	3	3	3	3	3	3
52c	- - -	SLEEVE, red, 2 in. (50.88 mm) x 0.16 OD	3	3	3	3	3	3

* See *Solenoid Valve Kits*, page 45.

● Parts included in Module Repair Kit. See *Module Repair Kit*, page 44.

■ Purchase Separately. See *Nozzles (Single Orifice)*, page 45.

▲ Replacement Warning labels, signs, tags, and cards are available at no cost.

Slim GS35

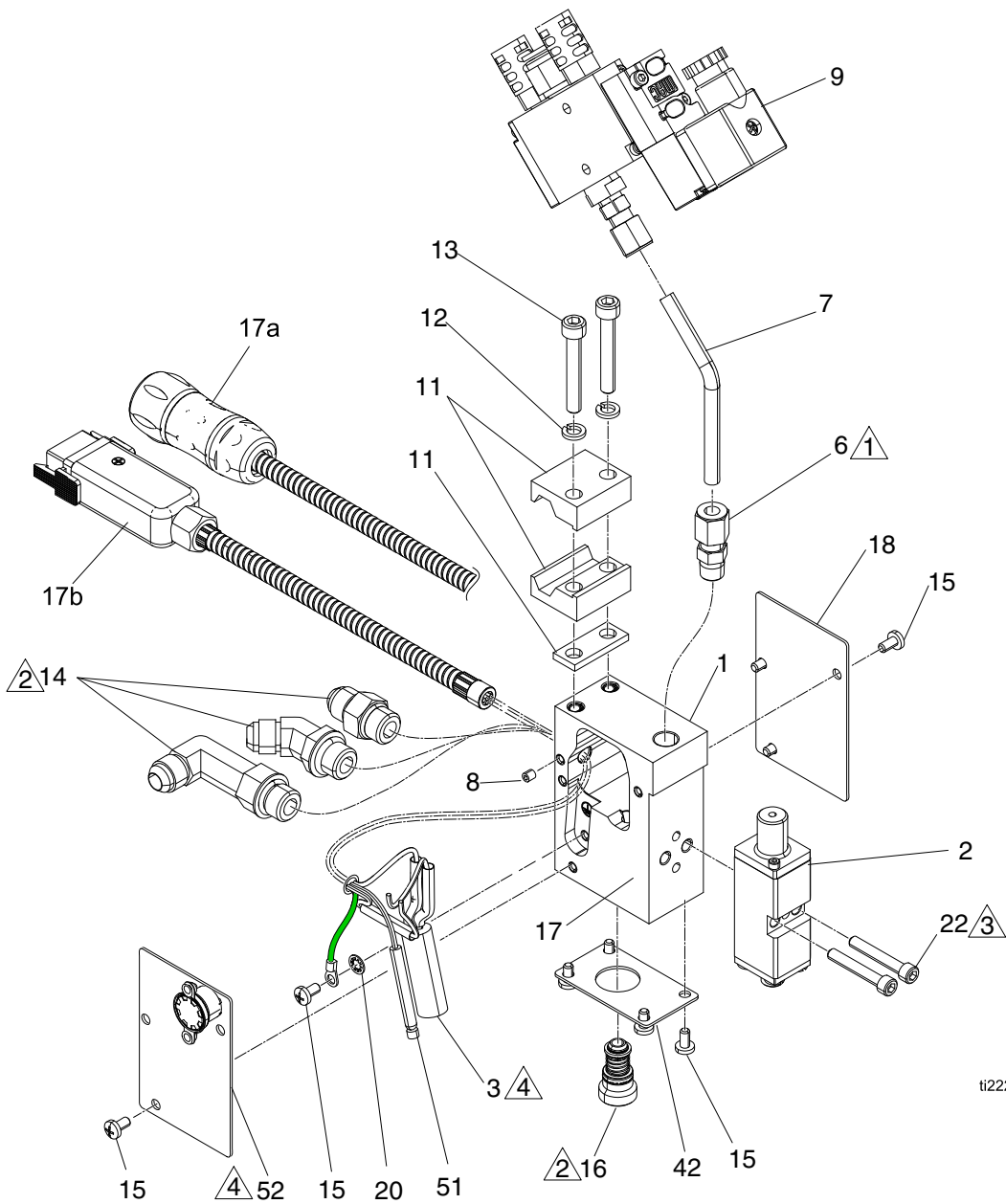

ti22236c

- △1 Apply thread sealant to threads.
- △2 Apply a thin coating of lubricant to seals.
- △3 Apply anti-seize to first 1/2 in. of threads. Torque to 28-32 in-lbs (3.2-3.6 N•m).
- △4 See [Wiring Diagram, page 21](#).

Table 7 Slim GS35

Ref	Part	Description	Quantity					
			24U021	24U022	24U023	24U024	24U025	24U026
1	---	HOUSING, slim	1	1	1	1	1	1
2●	---	MODULE	1	1	1	1	1	1
3	24V795	HEATER, 240 VAC, 200W, 1/2 dia. x 1.5 in.	1	1	1	1	1	1
6	100113	CONNECTOR, male	1	1		1	1	
7	16P769	TUBE, applicator, hotmelt, open	1	1		1	1	
8	124736	SCREW, set, cup, M4 x 0.7 x 4 mm, sst	1	1	1	1	1	1
9*	24P239	VALVE, solenoid, 3 way, sr, 24 VDC	1			1		
	24P240	VALVE, solenoid, 3 way, sr, 120 VAC		1			1	
10	24P276	INSULATOR, clamp, bar, housing	1	1	1	1	1	1
11	24P277	CLAMP, bar, housing	2	2	2	2	2	2
12	108050	WASHER, lock, spring	2	2	2	2	2	2
13	117030	SCREW, shcs M6 x 40	2	2	2	2	2	2
14	24P615	FITTING, adapter, JIC 06 x SAE 06, mm, cs	1	1	1	1	1	1
15	128306	SCREW, mach, phil pan hd	11	11	11	11	11	11
16	24P275	FILTER, gun, 80 mesh (3-pack: 24P802)	1	1	1	1	1	1
17a	24W087	CORD SET, 240V, applicator, Pt 100 ohm RTD	1	1	1			
17b	24W088	CORD SET, 240V, hotmelt, Ni 120 ohm RTD				1	1	1
18	---	PLATE, cover, side, slim	1	1	1	1	1	1
20	157021	WASHER, lock, int	1	1	1	1	1	1
22●	104705	SCREW, cap, sch	2	2	2	2	2	2
34	24P547	FITTING, elbow, JIC06 x SAE06, mm, cs	1	1	1	1	1	1
35	24P548	FITTING, elbow, 45, JIC06 x SAE06, mm, c	1	1	1	1	1	1
36■	---	NOZZLE (not shown)						
42	16W708	PLATE, cover, bottom, slim	1	1	1	1	1	1
51	16Y799	PLUG	1	1	1	1	1	1
52	24V792	KIT, THERMAL CUTOFF (includes 52a-52c)	1	1	1	1	1	1
52a	---	PLATE, with thermal cutoff	1	1	1	1	1	1
52b	---	CONNECTOR, splice, 14-16 AWG, heat resistant	3	3	3	3	3	3
52c	---	SLEEVE, red, 2 in. (50.88 mm) x 0.16 OD	3	3	3	3	3	3

* See [Solenoid Valve Kits](#), page 45.

● *Parts included in Module Repair Kit. See [Module Repair Kit](#), page 44.*

■ *Purchase Separately. See [Nozzles \(Single Orifice\)](#), page 45.*

Low Profile Dual GS35

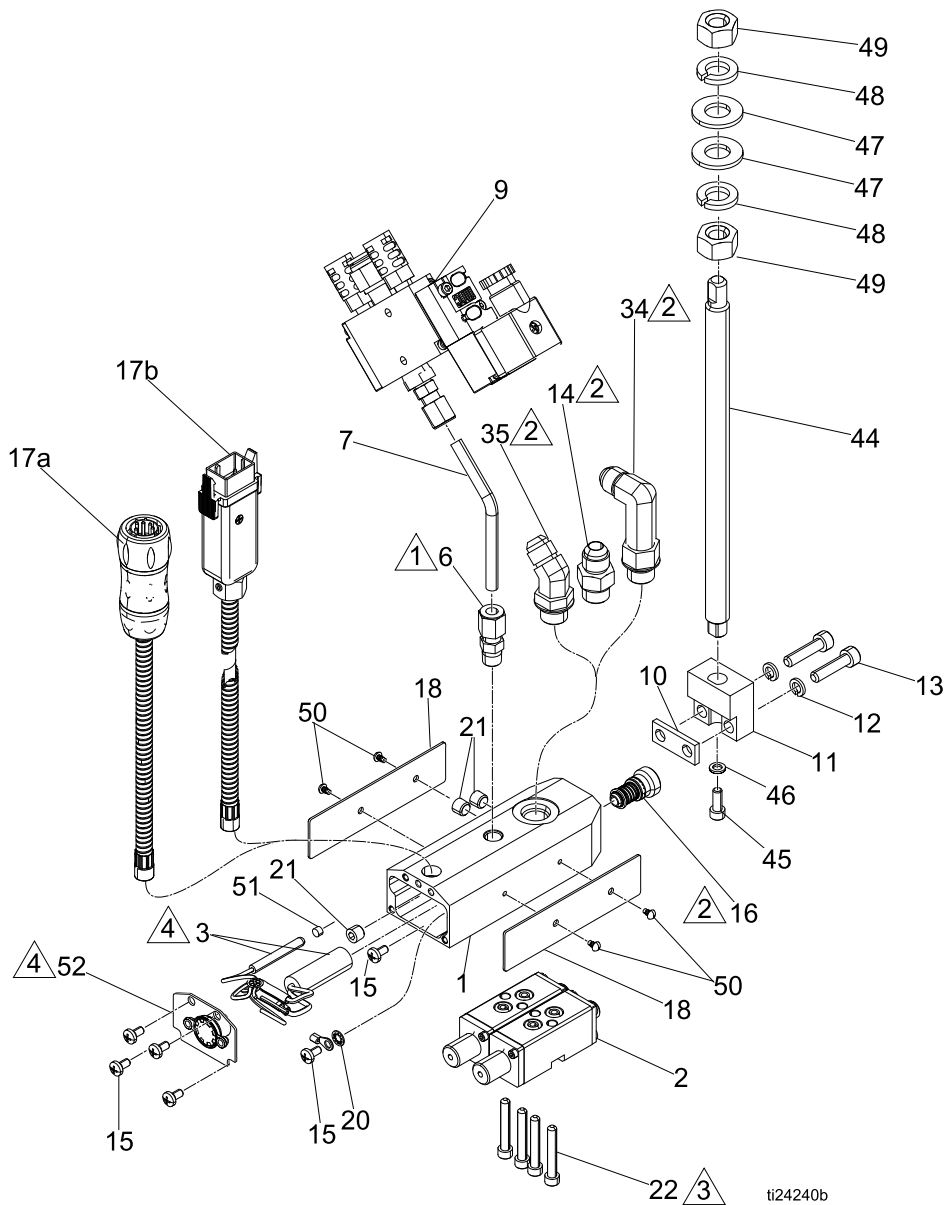

ti24240b



Apply thread sealant to threads.



Apply a thin coating of lubricant to seals.



Apply anti-seize to first 1/2 in. of threads. Torque to 28-32 in-lbs (3.2-3.6 N•m).



See [Wiring Diagram](#), page 21.

Table 8 Low Profile Dual GS35

Ref	Part	Description	Quantity					
			24U027	24U028	24U029	24U030	24U031	24U032
1	---	HOUSING, double	1	1	1	1	1	1
2●	---	MODULE, sc	2	2	2	2	2	2
3	24V795	HEATER, 240 VAC, 200W, 1/2 dia x 1.5 in.	1	1	1	1	1	1
6	100113	CONNECTOR, male	1	1		1	1	
7	16P769	TUBE, applicator, hotmelt, open	1	1		1	1	
8	124736	SCREW, set, cup, M4 x 0.7 x 4 mm, sst	1	1	1	1	1	1
9*	24P239	VALVE, solenoid, 3 way, sr, 24 VDC	1			1		
	24P240	VALVE, solenoid, 3 way, sr, 120 VAC		1			1	
10	24P276	INSULATOR, clamp, bar, housing	1	1	1	1	1	1
11	---	BLOCK	1	1	1	1	1	1
12	108050	WASHER, lock, spring	2	2	2	2	2	2
13	117029	SCREW, shcs, M6 x 25	2	2	2	2	2	2
14	24P615	FITTING, adapter, JIC06 x SAE06, mm, cs	1	1	1	1	1	1
15	128306	SCREW, mach, phil pan hd	5	5	5	5	5	5
16	24P275	FILTER, gun, 80 mesh (3-pack: 24P802)	1	1	1	1	1	1
17a	24W087	CORD SET, 240V, applicator, Pt 100 ohm RTD	1	1	1			
17b	24W088	CORD SET, 240V, hotmelt, Ni 120 ohm RTD				1	1	1
18	---	PLATE, side	1	1	1	1	1	1
20	157021	WASHER, lock, int	1	1	1	1	1	1
21	103147	PLUG, pipe	3	3	3	3	3	3
22●	104705	SCREW, cap, sch	4	4	4	4	4	4
34	24P547	FITTING, elbow, JIC06 x SAE06, mm, cs	1	1	1	1	1	1
35	24P548	FITTING, elbow, 45, JIC06 x SAE06, mm, c	1	1	1	1	1	1
36■	---	NOZZLE (not shown)						
42	16W709	PLATE, cover, end	1	1	1	1	1	1
44	24U698	ROD, mtg, threaded	1	1	1	1	1	1
45☼	102598	SCREW, cap, socket head	1	1	1	1	1	1
46☼	100020	WASHER, lock	1	1	1	1	1	1
47☼	109570	WASHER, plain	2	2	2	2	2	2
48☼	100018	WASHER, lock, spring	2	2	2	2	2	2
49☼	---	NUT, 1/2-13 hex	2	2	2	2	2	2
50	100508	SCREW, drive	4	4	4	4	4	4
51	16Y799	PLUG	1	1	1	1	1	1

Parts

Ref	Part	Description	Quantity					
			24U027	24U028	24U029	24U030	24U031	24U032
52	24V794	KIT, THERMAL CUTOFF (includes 52a-52c)	1	1	1	1	1	1
52a	- - -	PLATE, with thermal cutoff	1	1	1	1	1	1
52b	- - -	CONNECTOR, splice, 14–16 AWG, heat resistant	3	3	3	3	3	3
52c	- - -	SLEEVE, red, 2 in. (50.88 mm) x 0.16 OD	3	3	3	3	3	3

- * See [Solenoid Valve Kits, page 45](#).
- Parts included in Module Repair Kit. See [Module Repair Kit, page 44](#).
- ☆ Parts included in Bar Clamp Kit 24U698. See [Mounting Clamp Kits, page 45](#).
- Purchase Separately. See [Nozzles \(Single Orifice\), page 45](#).
- ▲ Replacement Warning labels, signs, tags, and cards are available at no cost.

Low Profile Quad GS35

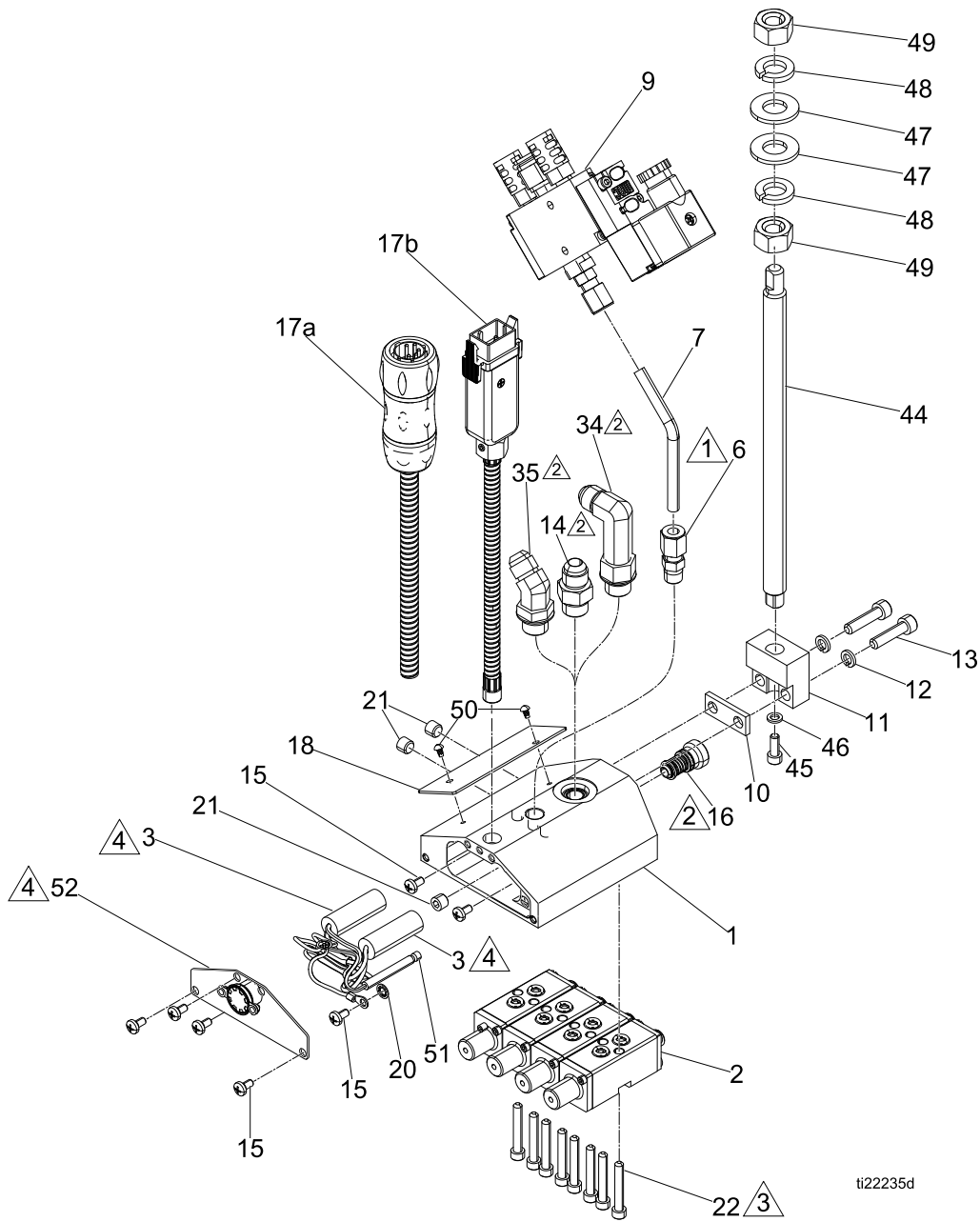

ti22235d

- | | |
|--|---|
| <p>△1 Apply thread sealant to threads.</p> <p>△2 Apply a thin coating of lubricant to seals.</p> | <p>△3 Apply anti-seize to first 1/2 in. of threads. Torque to 28-32 in-lbs (3.2-3.6 N•m)).</p> <p>△4 See Wiring Diagram, page 21.</p> |
|--|---|

Table 9 Low Profile Quad GS35

Ref	Part	Description	Quantity					
			24U033	24U034	24U035	24U036	24U037	24U038
1	---	HOUSING, quad	1	1	1	1	1	1
2●	---	MODULE, sc, invisipac	4	4	4	4	4	4
3	24V793	HEATER, 240 VAC, 200W, 1/2 dia x 1.5 in.	2	2	2	2	2	2
6	100113	CONNECTOR, male	1	1		1	1	
7	16P769	TUBE, applicator, hotmelt, open	1	1		1	1	
8	124736	SCREW, set, cup, M4x 0.7 x 4 mm, sst	1	1	1	1	1	1
9*	126407	VALVE, solenoid, 3 way, sr, 24 VDC	1			1		
	126408	VALVE, solenoid, 3 way, sr, 120 VAC		1			1	
10	16P848	INSULATOR, clamp, bar, housing	1	1	1	1	1	1
11	---	BLOCK, mtg	1	1	1	1	1	1
12	108050	WASHER, lock, spring	2	2	2	2	2	2
13	117029	SCREW, shcs M6 x 25	2	2	2	2	2	2
14	126544	FITTING, adapter, JIC06 x SAE06, mm, cs	1	1	1	1	1	1
15	128306	SCREW, mach, phil pan hd	6	6	6	6	6	6
16	24P275	FILTER, gun, 80 mesh (3-pack: 24P802)	1	1	1	1	1	1
17a	24W087	CORD SET, 240V, applicator, Pt 100 ohm RTD	1	1	1			
17b	24W088	CORD SET, 240V, hotmelt, Ni 120 ohm RTD				1	1	1
18	---	PLATE, side, quad	1	1	1	1	1	1
20	157021	WASHER, lock, int	1	1	1	1	1	1
21	103147	PLUG, pipe	3	3	3	3	3	3
22●	104705	SCREW, cap, sch	8	8	8	8	8	8
34	126748	FITTING, elbow, JIC06 x SAE06, mm, cs	1	1	1	1	1	1
	126749	FITTING, elbow, 45, JIC06 x SAE06, mm, c	1	1	1	1	1	1
36■	---	NOZZLE (not shown)						
38▲	16K931	TAG, warning, turbo	1	1	1	1	1	1
39	103473	STRAP, tie, wire	1	1	1	1	1	1
42	16V721	PLATE, cover, applicator	1	1	1	1	1	1
44	24U698	ROD, mtg, threaded	1	1	1	1	1	1
45☼	102598	SCREW, cap, socket head	1	1	1	1	1	1
46☼	100020	WASHER, lock	1	1	1	1	1	1
47☼	109570	WASHER, plain	2	2	2	2	2	2
48☼	100018	WASHER, lock, spring	2	2	2	2	2	2
49☼	---	NUT, 1/2-13 hex	2	2	2	2	2	2
50	100508	SCREW, drive	2	2	2	2	2	2
51	16Y799	PLUG	1	1	1	1	1	1

Parts

Ref	Part	Description	Quantity					
			24U033	24U034	24U035	24U036	24U037	24U038
52	24V796	KIT, THERMAL CUTOFF (includes 52a-52c)	1	1	1	1	1	1
52a	- - -	PLATE, with thermal cutoff	1	1	1	1	1	1
52b	- - -	CONNECTOR, splice, 14–16 AWG, heat resistant	3	3	3	3	3	3
52c	- - -	SLEEVE, red, 2 in. (50.88 mm) x 0.16 OD	3	3	3	3	3	3

* See [Solenoid Valve Kits, page 45](#).

• Parts included in Module Repair Kit. See [Module Repair Kit, page 44](#).

☆ Parts included in Bar Clamp Kit 24U698. See [Mounting Clamp Kits, page 45](#).

■ Purchase Separately. See [Nozzles \(Single Orifice\), page 45](#).

▲ Replacement Warning labels, signs, tags, and cards are available at no cost.

Solenoid Valve Kits

24P239, 24 VDC Solenoid Valve 24P240, 110 VAC Solenoid Valve

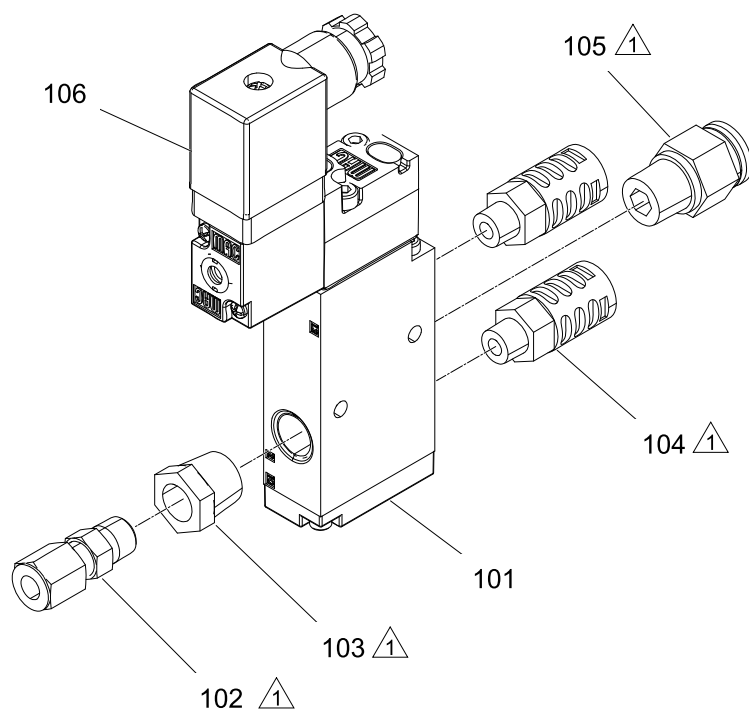

 Apply thread sealant to threads.

Ref	Part	Description	Qty	Ref	Part	Description	Qty
101	- - -	VALVE, solenoid, 3w, sr, 24 VDC; 24P239 only	1	104	24P282	MUFFLER, 1/8 npt, pp	2
	- - -	VALVE, solenoid, 3w, sr, 120 VAC; 24P240 only	1	105	121140	FITTING, straight, 3/8 tubing OD x 1/4 npt	1
102	100113	CONNECTOR, male	1	106	24R942	CONNECTOR, 24 VDC; 24P239 only	1
103	24P900	BUSHING, 1/4 npt x 1/8 npt, brass	1		24R943	CONNECTOR, 120 VAC; 24P240 only	1

Kits and Accessories

Module Replacement

24P241

See manual 407050.

Part	Description	Qty
----	MODULE	1
104705	SCREW, cap, sch; #10-32 x 1.25 in.	2
24R835	O-RING (10 pack)	2
24T179	LUBRICANT, anti-seize	1

Module Filter Replacement Kit

Includes instructions for replacing the module filter. See manual 332513.

Kit	Quantity
24P801	Single
24T045	3-pack

Module Rebuild Kit

NOTE: Requires Module Rebuild Tools Kit 24T206.

Includes instructions for rebuilding the module. See manual 332513.

Kit	Quantity
24T046	Single
24T047	5-pack

Module Rebuild Tools Kit 24T206

Part	Description	Qty
---	SEAL INSTALLATION TOOL	1
---	PISTON INSTALLATION TOOL	1

Cordsets

Cordsets include the RTD. Use crimp tool kit 24W086 (purchase separately).

Kit	RTD Type
24W087	Platinum 100 Ohm
24W088	Nickel 120 Ohm

Heater Cartridges

Heater cartridges for single, dual, and quad manifolds with butt splices, tape, and tubing. See [Models, page 6](#), for model numbers.

Kit	Manifold	Length
24V789	Single, Dual	1.5 in. (38 mm)
24V791	Quad	2.75 in. (70 mm)
24V795	Slim Single 24U021-24U026	1.5 in. (38 mm)
	Low Profile Dual 24U027-24U032	1.5 in. (38 mm)
24V793	Low Profile Quad 24U033-24U038	1.5 in. (38 mm)

Single Heater Cartridges with Ferrules

Single heater cartridges are for custom manifolds only.

Part	Length	Recommended Manifold Width
24P824	4 in. (101.6 mm)	5-6 in. (127-152.4 mm)
24P825	5 in. (127 mm)	6-7 in. (152.4-177.8 mm)
24P826	6 in. (152.4 mm)	7-8 in. (177.8-203.2 mm)
24P827	7 in. (177.8 mm)	8-9 in. (203.2-228.6 mm)
24P828	8 in. (203.2 mm)	9-12 in. (228.6-304.8 mm)

High Temperature Lubricant

24T156

Packet with 3-grams of high temperature lubricant. For use on seals in InvisiPac guns.

Anti-Seize

24T179

Tube with 0.5 oz of anti-seize for use on module mounting screws in InvisiPac guns.

Mufflers

24P282

Includes two mufflers that can be used with solenoid valve kits.

Blanking Plate Kit

24P810

Use to run two or three modules on a quad applicator or one module on a dual applicator. See manual 407051.

Solenoid Valve and Fitting Kits

3-Way (air open - spring close) Solenoid Valves

Kit	Description
24P239	24 VDC
24P240	110 VAC

Inlet Filter

Kit	Qty
24P275	Single
24P802	3 Pack

Material Inlet Fittings

Single Kit	Description
24P615	Straight
24P548	45°
24P547	90°

Thermal Cutoff Replacement Kits

For Series A and Series B Models.

Kit	Models	Description
24V790	See Models, page 6	Standard
24V792	24U021-24U026	Slim Single
24V794	24U027-24U032	Dual Low Profile
24V796	24U033-24U038	Quad Low Profile

Mounting Clamp Kits

See [Models, page 6](#) , for model numbers.

24P277 (Single, Dual, and Quad GS35)

Ref	Part	Description	Qty
10	24P276	INSULATOR, clamp, bar, housing	1
11	- - -	CLAMP, bar housing	2
12	108050	WASHER, lock, spring	2
13	117030	SCREW, shcs, M6 x 40	2

24U698 (Low Profile GS35, 24U027-24U038)

Ref	Part	Description	Qty
10	24P276	INSULATOR, clamp, bar, housing	1
11	- - -	BLOCK, mating, low profile	1
12	108050	WASHER, lock, spring	2
13	117029	SCREW, shcs, M6 x 25	2
44	- - -	ROD	1
45	- - -	SCREW, cap, socket head	1
46	- - -	WASHER, lock	1
47	- - -	WASHER, plain	2
48	- - -	WASHER, lock, spring	2
49	- - -	NUT, 1/2-13	2

Nozzles (Single Orifice)

Single	5 Pack	Description
24P636	24P794	0.008 straight
24P637	24P795	0.010 straight
24P638	24P796	0.012 straight
24P639	24P797	0.016 straight
24P640	24P798	0.018 straight
24P641	24P799	0.020 straight
24P642	24P800	0.024 straight
24P643	24P803	0.008 90°
24P644	24P804	0.010 90°
24P645	24P805	0.012 90°
24P646	24P806	0.016 90°
24P647	24P807	0.018 90°
24P648	24P808	0.020 90°
24P649	24P809	0.024 90°

Dimensions

Single, Dual, and Quad GS35

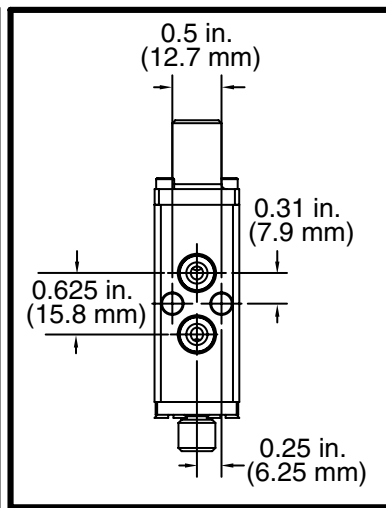
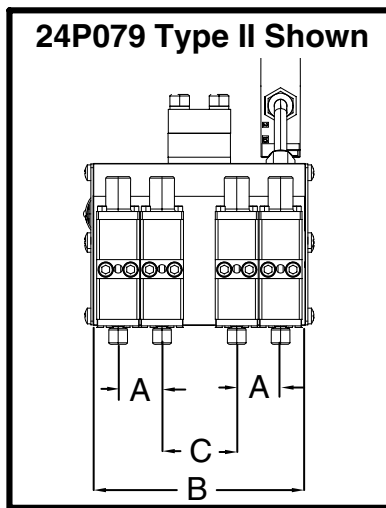
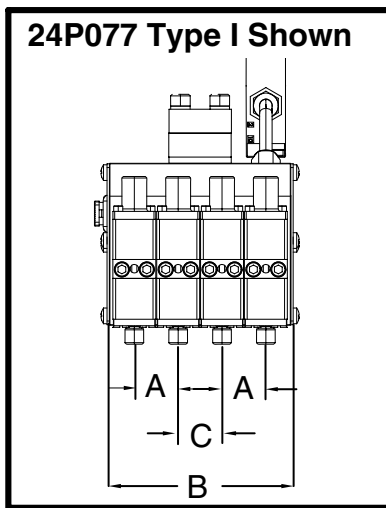
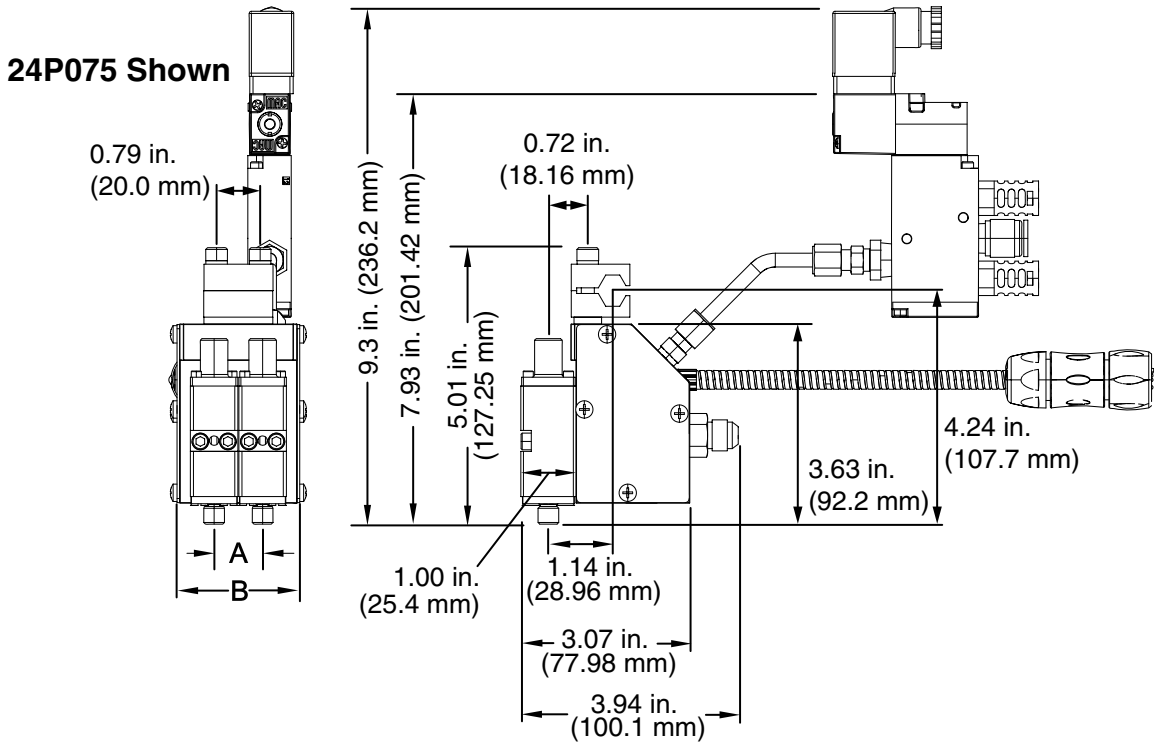

Applicator	A in. (mm)	B in. (mm)	C in. (mm)
Single		2.23 (56.6)	
Dual	0.88 (22.4)	2.23 (56.6)	
Quad - Type I	0.88 (22.4)	3.74 (95)	0.88 (22.4)
Quad - Type II	0.88 (22.4)	4.36 (111)	1.5 (38)

See [Models, page 6](#) , for applicator model numbers.

Slim GS35

(24U021-24U026)

24U021 Shown

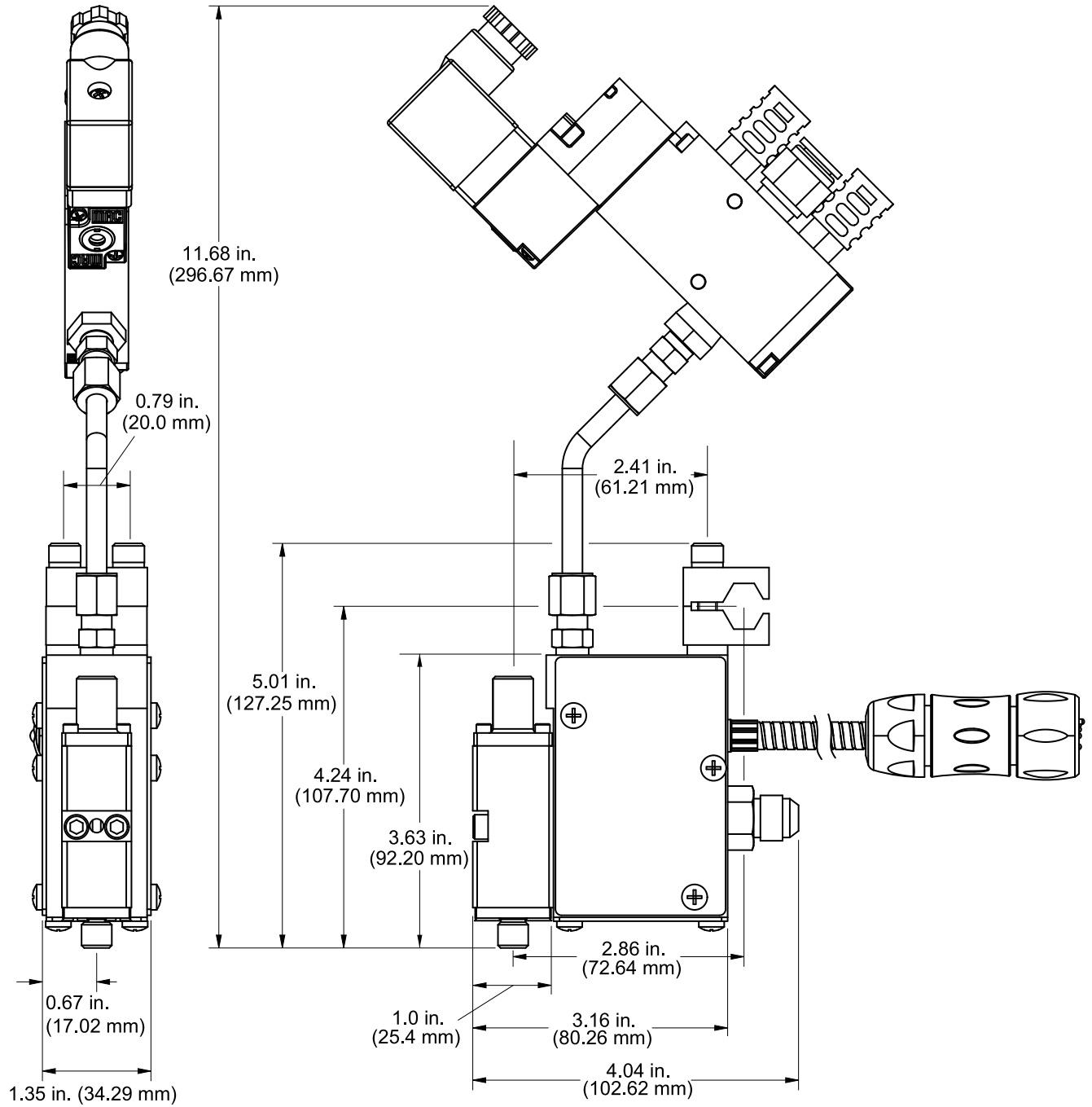

Dimensions

Low Profile Double GS35

(24U027-24U033)

24U027 Shown

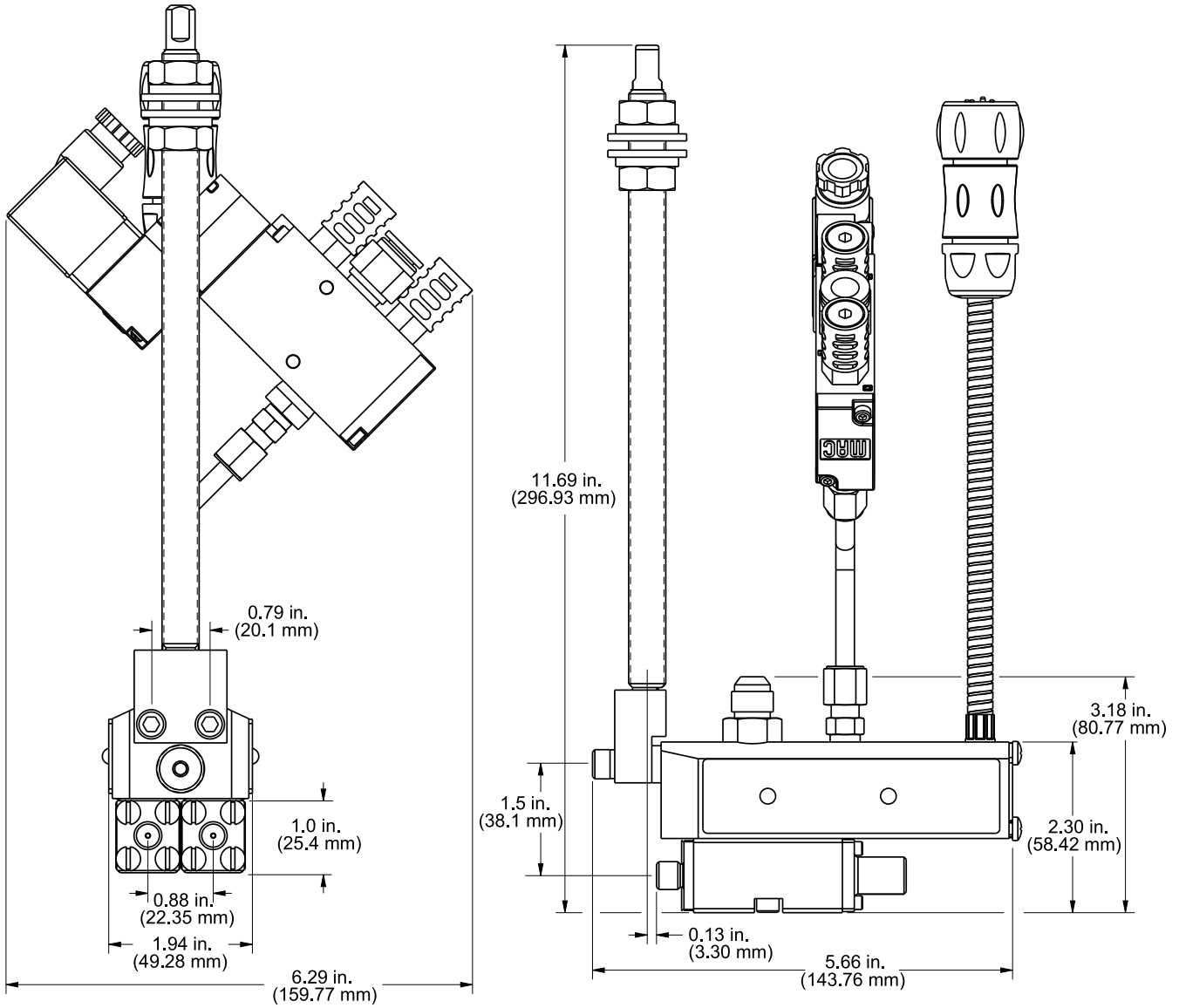

Low Profile Quad GS35

(24Ubob 033-24U038)

24U033 Shown

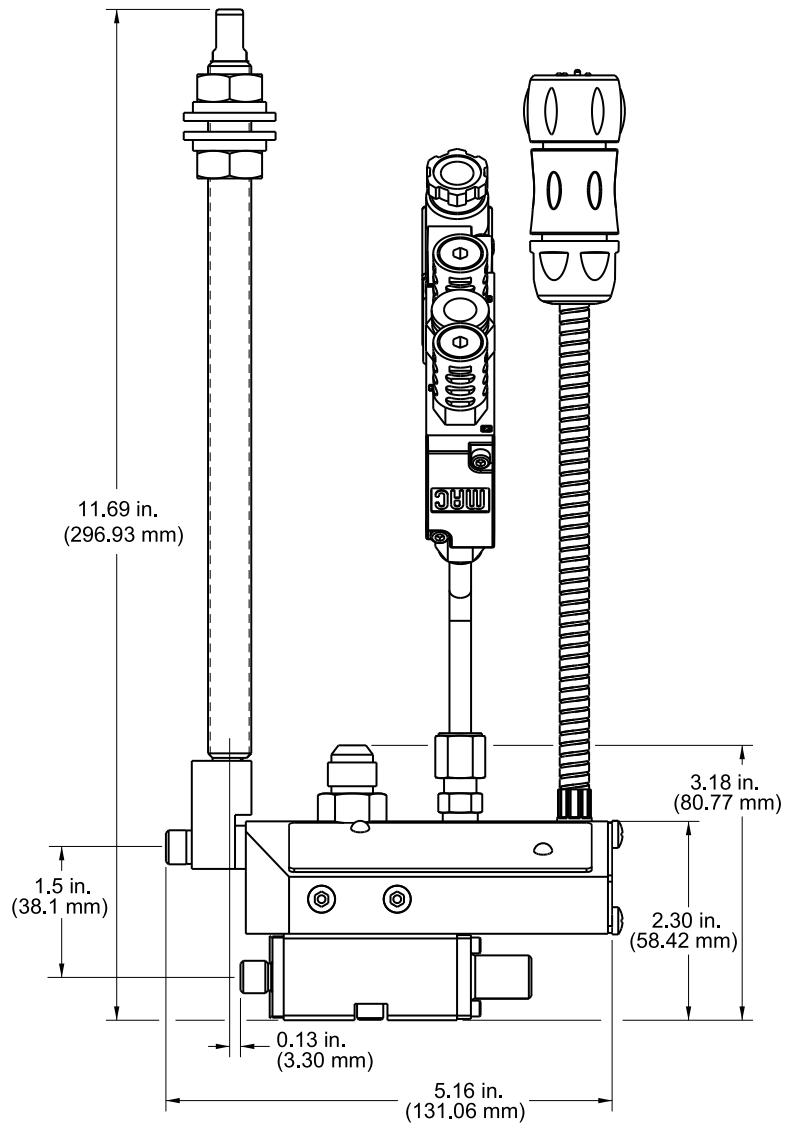
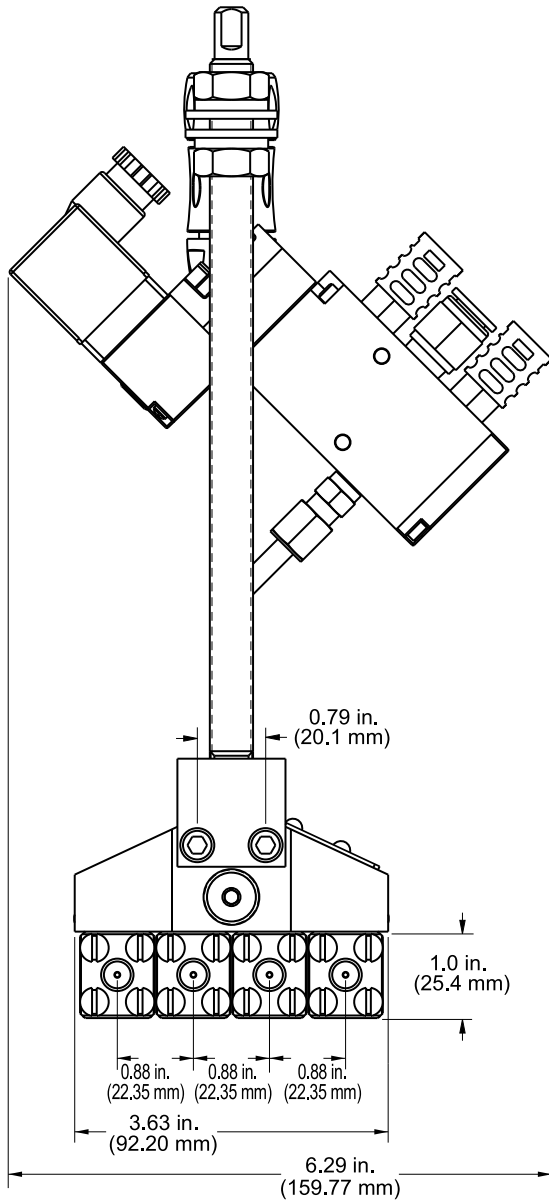

Technical Data

InvisiPac™ GS35 Plug-Free Hot Melt Adhesive Applicator		
	US	Metric
Speed	> 3,500 cycles/minute	
Heat up Time	< 10 minutes to 350°F at 240 VAC	< 10 minutes to 176°C at 240 VAC
Electrical Service	200-240V, 50-60 Hz, 400W	
Maximum Working Fluid Pressure	1500 psi	10.3 MPa, 103 bar
Maximum Air Pressure	80 psi	0.5 MPa, 5.5 bar
Minimum Air Pressure	40 psi	0.3 MPa, 2.7 bar
Maximum Operating Temperature	400°F	204°C
Ambient Storage Temperature Range	32-122°F	0-50°C
Ambient Operating Temperature Range	32-122°F	0-50°C
Solenoid Air Flow Rating	1.0 Cv	
Wetted Parts	Aluminum, carbon steel, stainless steel, carbide, brass, chemically resistant seals, chrome	
Cordsets		
24W087	Pt 100 (385) RTD	
24W088	Ni 120 RTD	
Solenoid Control Voltages		
24P239	24 VDC	
24P240	110 VAC	
Noise		
Sound pressure measured 6.5 ft (2m) from gun at 80 psi (550kPa, 5.5 bar)	75.6 dB(A)	

Graco Extended Warranty

Graco warrants all equipment referenced in this document which is manufactured by Graco and bearing its name to be free from defects in material and workmanship on the date of sale to the original purchaser for use. With the exception of any special, extended, or limited warranty published by Graco, Graco will, for a period of eighteen months from the date of sale, repair or replace any part of the equipment determined by Graco to be defective. This warranty applies only when the equipment is installed, operated and maintained in accordance with Graco's written recommendations.

This warranty does not cover, and Graco shall not be liable for general wear and tear, or any malfunction, damage or wear caused by faulty installation, misapplication, abrasion, corrosion, inadequate or improper maintenance, negligence, accident, tampering, or substitution of non-Graco component parts. Nor shall Graco be liable for malfunction, damage or wear caused by the incompatibility of Graco equipment with structures, accessories, equipment or materials not supplied by Graco, or the improper design, manufacture, installation, operation or maintenance of structures, accessories, equipment or materials not supplied by Graco.

This warranty is conditioned upon the prepaid return of the equipment claimed to be defective to an authorized Graco distributor for verification of the claimed defect. If the claimed defect is verified, Graco will repair or replace free of charge any defective parts. The equipment will be returned to the original purchaser transportation prepaid. If inspection of the equipment does not disclose any defect in material or workmanship, repairs will be made at a reasonable charge, which charges may include the costs of parts, labor, and transportation.

THIS WARRANTY IS EXCLUSIVE, AND IS IN LIEU OF ANY OTHER WARRANTIES, EXPRESS OR IMPLIED, INCLUDING BUT NOT LIMITED TO WARRANTY OF MERCHANTABILITY OR WARRANTY OF FITNESS FOR A PARTICULAR PURPOSE.

Graco's sole obligation and buyer's sole remedy for any breach of warranty shall be as set forth above. The buyer agrees that no other remedy (including, but not limited to, incidental or consequential damages for lost profits, lost sales, injury to person or property, or any other incidental or consequential loss) shall be available. Any action for breach of warranty must be brought within two (2) years of the date of sale.

GRACO MAKES NO WARRANTY, AND DISCLAIMS ALL IMPLIED WARRANTIES OF MERCHANTABILITY AND FITNESS FOR A PARTICULAR PURPOSE, IN CONNECTION WITH ACCESSORIES, EQUIPMENT, MATERIALS OR COMPONENTS SOLD BUT NOT MANUFACTURED BY GRACO. These items sold, but not manufactured by Graco (such as electric motors, switches, hose, etc.), are subject to the warranty, if any, of their manufacturer. Graco will provide purchaser with reasonable assistance in making any claim for breach of these warranties.

In no event will Graco be liable for indirect, incidental, special or consequential damages resulting from Graco supplying equipment hereunder, or the furnishing, performance, or use of any products or other goods sold hereto, whether due to a breach of contract, breach of warranty, the negligence of Graco, or otherwise.

FOR GRACO CANADA CUSTOMERS

The Parties acknowledge that they have required that the present document, as well as all documents, notices and legal proceedings entered into, given or instituted pursuant hereto or relating directly or indirectly hereto, be drawn up in English. Les parties reconnaissent avoir convenu que la rédaction du présente document sera en Anglais, ainsi que tous documents, avis et procédures judiciaires exécutés, donnés ou intentés, à la suite de ou en rapport, directement ou indirectement, avec les procédures concernées.

Graco Information

For more information about InvisiPac, visit www.InvisiPac.com or email InvisiPac@graco.com.

To place an order, contact your Graco Distributor or call to identify the nearest distributor.

For technical assistance or customer service, call toll free: 1-800-458-2133.

All written and visual data contained in this document reflects the latest product information available at the time of publication.

Graco reserves the right to make changes at any time without notice.

For patent information, see www.graco.com/patents.

Original Instructions. This manual contains English. MM 3A2805

Graco Headquarters: Minneapolis

International Offices: Belgium, China, Japan, Korea

GRACO INC. AND SUBSIDIARIES • P.O. BOX 1441 • MINNEAPOLIS MN 55440-1441 • USA

Copyright 2012, Graco Inc. All Graco manufacturing locations are registered to ISO 9001.

www.graco.com

Revision M, July 2018