

# Manzel® Model 88 Pump

## DESCRIPTION

The Model 88 Pump is a heavy-duty precision metering pump capable of accurately pumping small flows of either mineral or synthetic oil to machinery injection points. The single-piston pump is mechanically driven from a camshaft in the reservoir and is adjustable from 1 to 27 drops per stroke, depending on the piston size. The pump can develop pressures up to 7500 psi, depending on the piston size. All working parts are totally enclosed away from dirt, water, and impurities and self-lubricated at all times by the fluid in the reservoir.

Model 88 Pumps are designed for use in Manzel® Model 55 and 76 Box Lubricators, and in Mega, Lincoln and Premier Model 55 Box Lubricators. The output ranges vary slightly depending on the lubricator.

Model 88 Pumps are rugged, heavy duty units. Each pump includes a precision machined steel sleeve fitted with an alloy steel piston.

The pump is actuated by a hardened steel roller - rocker following a cam for low wear and longer life. The visual sight well is one-piece injection molded material that is impervious to ultra-violet rays, and mineral and synthetic oils.

Three (3) piston sizes are available to produce outputs up to 27 drops per stroke in Manzel Box Lubricators and up to 20 drops per stroke in Mega, Lincoln and Premier Model 55 Box Lubricators.

## FEATURES/BENEFITS

- Rugged construction for high performance and durability
- Suction and gravity/pressure feed models for application flexibility
- Pump output is easily adjustable
- Hardened cam roller adds to pump and cam life
- One piece sight glass means fewer leak path and seal points

## OPERATION

### Pumps With Vacuum Feed (Sight Glass Type)

Rotation of the lubricator cam actuates the pump rocker arm assembly to operate the pump piston. On the piston downstroke, spring force is exerted on the piston causing it to follow the cam. As it moves down, a pressure reduction is created in the area between the piston and the discharge check valve. The supply inlet shutoff



ball is concurrently unseated and lubricant is drawn into the piston cylinder from the sight well. This action creates a pressure reduction (vacuum) in the air-tight sight well, causing lubricant from the reservoir to be drawn into the well until pressure is equalized. On the piston upstroke, the oil in the piston cylinder reseats the inlet shutoff ball and is forced out through the discharge check valve to the machine injection point.

The number of drops seen falling in the sight well equals the amount of oil discharged by the pump. Pump volume can be adjusted by means of an external screw. This changes the length of the piston stroke which changes the pump discharge volume.

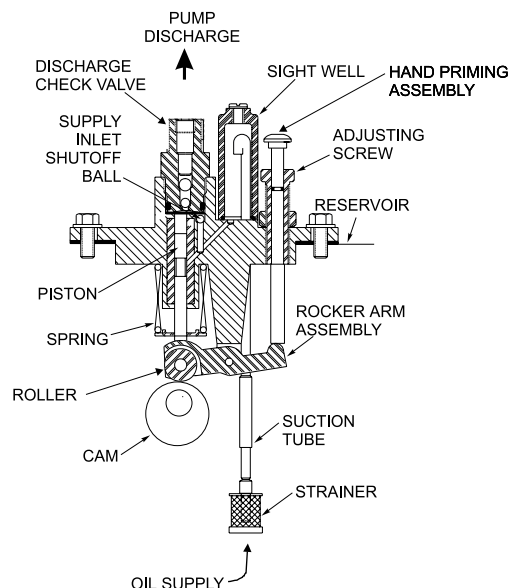

### Pumps With Gravity Feed and Pressurized Supplies

Rotation of the lubricator cam actuates the pump rocker arm assembly to operate the pump piston. On the piston downstroke, spring force is exerted on the piston causing it to follow the cam. As it moves down, a pressure reduction is created in the area between the piston and the discharge check valve. The gravity feed or pressurized supply unseats the supply inlet shutoff ball and fills the piston bore with lubricant. On the piston upstroke, the oil in the piston cylinder reseats the inlet shutoff ball and is forced out through the discharge check valve to the machine injection point. Pump volume can be adjusted by means of an external screw. This changes the length of the piston stroke which changes the pump discharge volume.

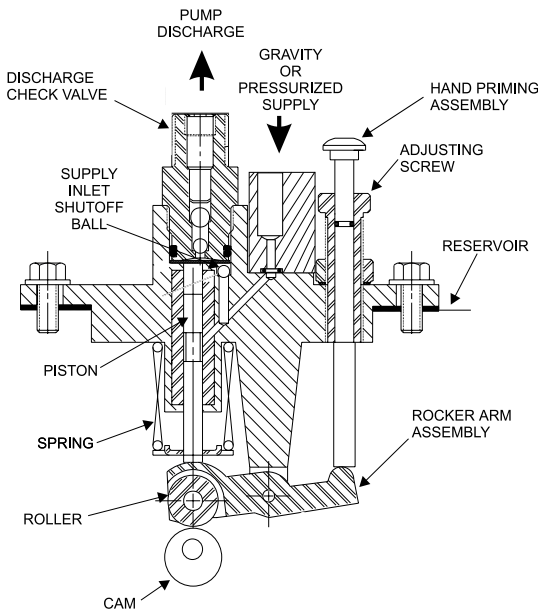

### ADJUSTMENT

Pump discharge (output flow) can be adjusted within the min./max. ranges as shown in the illustration. The adjustment is linear. Therefore, positioning the screw midway will produce one-half of the pump capacity. To adjust the flow, proceed as follows:

1. Loosen adjusting screw locknut.
2. Turn the adjusting screw to the desired position and, with the pump operating, count the drops falling in the sight well for a one-minute interval.
3. Tighten adjusting screw locknut.

### Calculate Pints Per Day As Follows:

$$\frac{\text{Number of Drops/Min.} \times 1440 \text{ (Minutes in a Day)}}{14115 \text{ (Number of drops in a Pint)}} = \text{Pints/Day}$$

### Calculate Minimum or Maximum Pump Output Capacity

$$\frac{\text{Input Speed} \times \text{Pump Output} \times 1440}{\text{Gear Ratio} \times \left( \frac{\text{Min. or Max. drops/stroke}^*}{\text{Min. or Max. Pump Output (Pints Per Day)}} \right)} =$$

\* Minimum and Maximum Drops Per Stroke Listed in Specifications on the next page.

**NOTE:** For proper sizing select the appropriate lubricator brand. Brand as well as piston size will effect minimum and maximum pump capacity.

The following example is a Manzel lubricator, electric motor driven, 300:1 internal ratio, 1/4" pump model 88. Solve for maximum flow:

$$\frac{1725 \text{ Motor Speed} \times \text{Max. 12 drops} \times 1440 \text{ Min.}}{300:1 \text{ Gear Ratio} \times \text{per stroke}} = \text{Max. 7.04 Pints/day}$$

To Calculate Minimum: Replace the maximum 12 drops per stroke with the minimum 2 drops per stroke: (1.17 minimum pints per day)

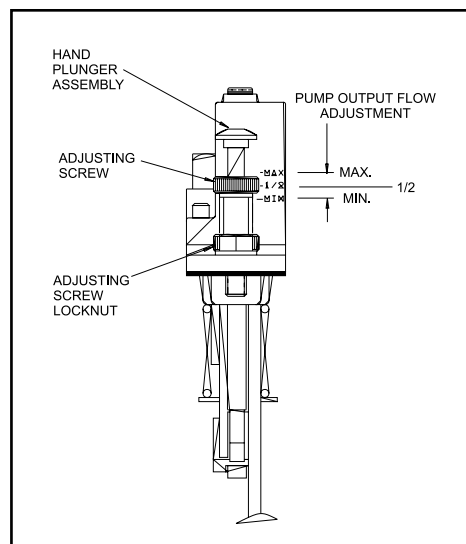

\*Should not reciprocate up and down as pump operates, on pumps built beginning in January 1997.

SPECIFICATIONS												
Pump Model <sup>4</sup>		Piston Dia (inches)	Max Pressure <sup>3</sup> (psi)	Drops/Stroke <sup>1&amp;2</sup>		Cu.In./Stroke		Cu.Cm/Stroke		Stroke/Minute		Stroke Length (inches)
				Max	Min	Max	Min	Max	Min	Max	Min	
In Manzel Lubricator (55 and 76)	88B, F, J	3/16	7500	6	1	0.013	0.002	0.213	0.033	50	3	1/2
	88C, G, K	1/4	6000	12	2	0.024	0.004	0.393	0.066	50	3	
	88E, H, L	3/8	2500	27	4	0.055	0.004	0.901	0.131	50	3	
In Mega, Lincoln or Premier Lubricators	88B, F, J	3/16	7500	5	1	0.009	0.002	0.148	0.033	50	3	3/8
	88C, G, K	1/4	6000	9	2	0.018	0.004	0.295	0.066	50	3	
	88E, H, L	3/8	2500	20	4	0.041	0.004	0.672	0.131	50	3	

1. Based on 500 SUS oil at 70°F ambient. Heavier oil will produce fewer but larger drops.
2. When approaching maximum outputs, some oils will stream rather than form drops in sight glass.
3. For operating pressures over 50% of the rated maximum, consult the factory.
4. Allowable viscosity range independent of temperature: 80-5000 SUS.
5. Maximum allowable inlet pressure: Pressurized pump, 100 PSI; Pressurized pump with sight glass, 10 PSI.

**NOTE:** Any static positive pressure applied to the pump inlet has the potential to cause leakage flow through a pump at rest or adjusted for zero stroke unless offset by a check valve of comparable pressure rating located at the pump outlet. The "discharge check valve" pictured has no spring and is rated at zero PSI. The "outlet check valve" pictured in phantom in view at bottom of next page is rated at 35 PSI.

ORDERING INFORMATION									
Pump Piston Size	Vacuum Feed Pump			Gravity Feed Pump & Pressurized Pump <sup>5</sup>			Gravity Feed Pump w/Sight Glass <sup>5</sup>		
	Model	Part No.	Old Part No.	Model	Part No.	Old Part No.	Model	Part No.	Old Part No.
3/16 in	88B	562954	376-000-001	88F	562962	376-000-121	88J	564011	376-000-530
1/4 in	88C	562956	376-000-011	88G	562964	376-000-131	88K	562967	376-000-540
3/8 in	88E	562958	376-000-031	88H	562966	376-000-151	88L	562968	376-000-560

### Model 88 Pumps Configured for Mega, Lincoln and Premier Box Lubricator, and for Manzel Model 55 Lubricator

Model 88 Pumps are interchangeable with Mega, Lincoln and Premier Model 55 Pumps. Use the following table to determine the appropriate part number.

ORDERING INFORMATION						
Description	Pump Size	Part No.	Old Part No.	Mega Part No.	Premier Part No.	Lincoln Part No.
*Vacuum Pumps (B)	3/16	562954	**376-000-001	-	-	-
*Vacuum Pumps (C)	1/4	562956	**376-000-011	039315	91200/91220	880187/880550
*Vacuum Pumps (E)	3/8	562958	**376-000-031	039308	91201/91221	880330/880560
Press Supply (F)	3/16	562962	376-000-121	-	-	-
Press Supply (G)	1/4	562964	376-000-131	039488	91202	880453/880552
Press Supply (H)	3/8	562966	376-000-151	039489	91203	880454
Press Supply w/Sight Glass (J)	3/16	564011	376-000-530	-	-	-
Press Supply w/Sight Glass (K)	1/4	562967	376-000-540	-	-	-
Press Supply w/Sight Glass (L)	3/8	562968	376-000-560	-	-	-
Press Supply to Front	3/16	562962	†376-000-121	-	-	-
Press Supply to Front	1/4	562964	†376-000-131	038704	91208	880087-X
Press Supply to Front	3/8	562966	†376-000-151	038705	91209	880402-X
Press Supply to Rear	3/16	562962	†376-000-121	-	-	-
Press Supply to Rear	1/4	562964	†376-000-131	038702	91206	880087-CL
Press Supply to Rear	3/8	562966	†376-000-151	038703	91207	880402-CL
Press Supply w/Shutoff	3/16	562962	†376-000-121	-	-	-
Press Supply w/Shutoff	1/4	562964	†376-000-131	039425	91204	880087
Press Supply w/Shutoff	3/8	562966	†376-000-151	038153	91205	880402

\*When configured from the factory to fit into Model 55, Mega, Lincoln or Premier Box Lubricators, the vacuum pump has a 0.875 in shortened suction tube.

\*\*Model 88B, C and E pumps can be field modified to fit Mega, Lincoln and Premier Box Lubricators. Remove the strainer, break off the suction tube at the V-groove, and replace the strainer.

†Graco will provide pump replacement only, customer to supply tubing and fittings for rear, front and shutoff pumps.

# MANZEL MODEL 88 PUMP OPERATING INSTRUCTIONS

1. Fill the box lubricator reservoir, to the top of the sight level gauge, with oil, filtered through a 25 micron nominal strainer. (Machine requirements may dictate a higher oil cleanliness level.)
2. Expel all air from the pump. **NOTE: Do not connect the oil line to the pump outlet or lube point until all air has been expelled.** To Expel Air From The Pump:
  - a. Remove the sight well plug.
  - b. Fill the sight well to the top with filtered oil.
  - c. Operate the hand priming assembly until the oil level drops below the end of the drip tube.
  - d. Replace the sight well plug.
  - e. Continue to hand prime until oil from the drip tube is free of air.
  - f. If all oil is evacuated from sight well, repeat steps (a) through (e) as often as necessary, until all air has been expelled.
4. Connect the tubing to the pump outlet.
5. Hand prime the pump until clean, air-free oil is flowing through the lube line.
6. Connect the tubing to the lube point.
7. The lubricator is now ready to operate. After start-up, the lubricator may require adjustment of the individual pumps to meet required flow rates.
8. To adjust The Pump:
  - a. Loosen the adjusting screw lock nut.
  - b. Turn the adjusting screw clockwise or counterclockwise to decrease or increase flow.
  - c. With the lubricator operating, count the drops falling into the sight well for one minute.
  - d. If any further adjustment is necessary, turn the adjustment screw; 1) counterclockwise to increase flow (drops per minute); or 2) clockwise to decrease flow (drops per minute).
- e. Repeat (7-c) to assure that the pump is adjusted to the proper specification.
- f. Once the pump has been adjusted to the proper specification, tighten the adjusting screw locknut.
9. The recommended minimum flow rate is 2 drops per stroke. Operators are cautioned against decreasing the oil flow below this rate, as a pump malfunction may occur.
10. The minimum recommended strokes per minute is 3. The maximum recommended strokes per minute is 50. **NOTE:** To maximize pump life, it is recommended that the pump not exceed 20 strokes per minute.
11. Oil level in the sight well will stabilize promptly, then rise and fall slightly during pump operation. Should oil level in the sight well rise above the drip tube:
  - a. Remove the sight well plug.
  - b. Allow the pump to continue to operate until the oil level has dropped below the drip tube.
  - c. Replace the sight well plug. **NOTE:** This condition is not uncommon for a vacuum type pump. However it could be an indication of a problem with the supply inlet shutoff ball/seat. If this condition persists, check the ball and seat. If there are no apparent problems there, the piston and bore are worn and the pump should be replaced.
12. Should oil level in the sight well fall below the pump body surface:
  - a. Remove the sight well plug.
  - b. Allow the pump to continue to operate, and manually fill the sight well with filtered oil to below the end of the drip tube.
  - c. Replace the sight well plug. **NOTE:** This condition could be an indication of a problem with the seal between the sight glass and pump body surface, or with the sight well plug. Check parts for nicks, cuts and sealing capability. Replace parts using Repair Kit Part No. 564437 (560-001-860) if needed.
13. The MANZEL MODEL 88 PUMP will operate in a Manzel, Mega, Lincoln, or Premier lubricator. For more information about the Manzel Force Feed Box Lubricator, refer to Manzel Bulletin L51020 and/or L51040.

## PUMP DIMENSIONS

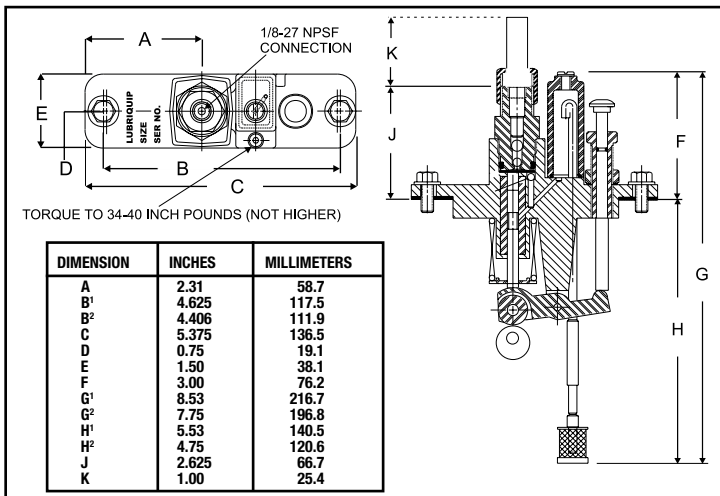

B1/G1/H1 - in Manzel "76" Lubricator; B2/G2/H2 - in Manzel "55" Mega, Lincoln and Premier Lubricator.

## PUMP REPAIR KITS

- Pump repair kits are the same for both vacuum feed and gravity feed with sight glass pumps in all pump sizes. Repair kits may be ordered by part number 564437 (560-001-860) and contain only parts necessary to replace the pump sight glass.
- Body/sleeve and piston subassembly is not sold separately.

FLUID MEASUREMENT CONVERSION DATA	
1 Drop	approx 0.002 cu.in.
14,115 Drops	1 pint
28.89 cu.in.	1 pint
490 Drops	1 cu.in.
10 Drops/Min	1 pint/24 hours
30 Drops	1cc

All written and visual data contained in this document are based on the latest product information available at the time of publication. Graco reserves the right to make changes at any time without notice.

## Contact us today!

To receive product information or talk with a Graco representative, call 800-533-9655 or visit us online at [www.graco.com](http://www.graco.com).

