

CycleFlo™ Pneumatic Pump Controller

309003H

EN

Controls pump speed, run time, and quantity of product delivered, for precise batching, metering, and dosing of fluids at high or low pressures and flow rates.

Not for use in explosive atmospheres.

Part No. 195264

120 psi (0.8 MPa, 8 bar) Maximum Air Inlet Pressure

- Integrated Air Valves with Silenced Exhaust
- 32 Batch Presets
- 1-999 Pump Cycles per Batch Preset
- x10 Cycle Multiplier for High Volume Applications (10-9990 Cycles)
- 16 Pump Cycle Rates (10-200 CPM)
- Easy Field Programming
- Self-Test Function for Easy Troubleshooting
- 100-240 VAC Input Power



Important Safety Instructions

Read all warnings and instructions in this manual. Save these instructions.

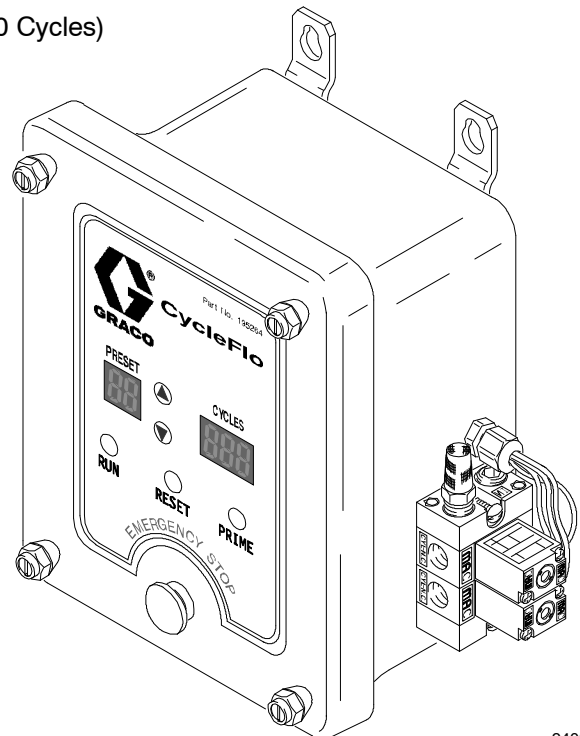

9408B

Table of Contents

Symbols	3	Priming the Pump	9
Warnings	3	Front Panel Operation	9
General Description	5	Remote Operation	9
Installation	6	Troubleshooting	10
Pneumatic Connections	6	Self-Test Mode	11
Electrical Connections	6	Parts	12
Setup and Programming	8	Typical Installation Diagrams	13
Cycles Per Minute (CPM) Rate	8	Specifications	17
Presets	8	Mounting Information	17
Operation	9	Graco Standard Warranty	18
		Graco Information	18

Symbols

Warning Symbol



This symbol alerts you to the possibility of serious injury or death if you do not follow the corresponding instructions.

Caution Symbol



This symbol alerts you to the possibility of damage to or destruction of equipment if you do not follow the corresponding instructions.

WARNING



INSTRUCTIONS

EQUIPMENT MISUSE HAZARD

Equipment misuse can cause the equipment to rupture or malfunction and result in serious injury.

- This equipment is for professional use only.
- Read all instruction manuals, warnings, tags, and labels before operating the equipment.
- Use equipment only for its intended purpose. If you are uncertain about usage, call your Graco distributor.
- Other than for installation purposes, do not alter or modify this equipment. Use only genuine Graco parts and accessories.
- Check equipment daily. Repair or replace worn or damaged parts immediately.
- Do not exceed the maximum working pressure of the lowest rated system component.
- Route hoses away from traffic areas, sharp edges, moving parts, and hot surfaces. Do not expose Graco hoses to temperatures above 82° C (180° F) or below -40° C (-40° F).
- Do not lift pressurized equipment.
- Comply with all applicable local, state and national fire, electrical, and other safety regulations.

WARNING



FIRE, EXPLOSION, AND ELECTRIC SHOCK HAZARD

Improper grounding, poor air ventilation, open flames, or sparks can cause a hazardous condition and result in fire or explosion and other serious injury.

- Ground the pumping equipment. Proper grounding dissipates static electricity.
- This equipment is not intended for intrinsically safe areas.
- Keep the dispense area free of debris, including solvent, rags, and gasoline.
- If there is any static sparking or you feel an electric shock while using the equipment, **stop operating immediately**. Do not use the equipment until you have identified and corrected the problem.
- Make sure all electrical work is performed by a qualified electrician.
- Have any checks, installation, or service to electrical equipment performed by a qualified electrician only.
- Make sure all electrical equipment is installed and operated in compliance with local and applicable codes.
- Make sure power is disconnected when servicing and repairing equipment.
- Keep liquids away from the electrical components.
- Disconnect electrical power at the main switch before servicing equipment.
- Never exceed maximum wattage of the supply unit.

General Description

The CycleFlo is a pneumatic pump controller that allows precise control over the amount of product that is delivered by the pump, as well as the pump speed. The CycleFlo achieves this by operating the pump for a preset number of cycles and then halting the pumping cycle. Up to 32 different batch sizes may be programmed into the memory of the CycleFlo for easy delivery of different product volumes.

A batch may be initiated either from the front panel RUN button or via a remote switch. Such a remote switch may be connected to the trigger of a dispensing valve so that the pump only pumps when the operator depresses the valve trigger. Using the remote input, the pumping cycle may also be initiated by some other piece of equipment such as a timer or a pH controller. The CycleFlo will halt the pumping cycle once the preset volume of product has been dispensed.

The CycleFlo also features an adjustable pumping rate. This allows the CycleFlo to be used with different pump types and also to tailor the pump cycle to deliver fluids with a variety of flow characteristics.

Installation

Pneumatic Connections

The integrated air valves (solenoids #1 and #2), located on the right side of the CycleFlo enclosure, have a common air inlet (1/4 in. npt) port at the bottom and two outlet ports (1/8 in. npt to 1/4 in. elbow tube fitting) towards the front of the unit. The exhaust is silenced with a muffler.

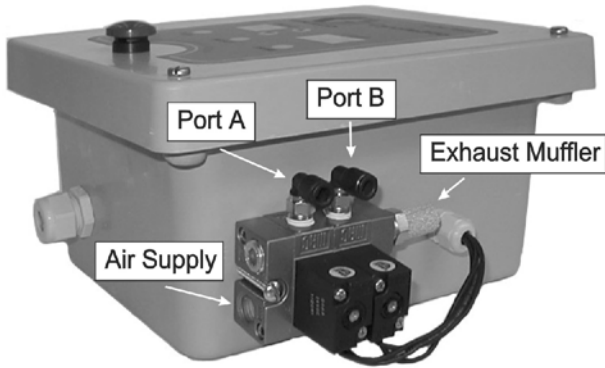

Fig. 1

The A and B outlet ports are to be connected to the A and B ports, respectively, on the Husky™ 205, or to the two air valve control ports located on the air motors of pumps larger than the Husky 205. The unit comes equipped with 1/4 in. OD push-in tube fittings installed in the A and B ports.

On pumps larger than the Husky 205, a three-way solenoid valve (Graco Part No. 115605 or equivalent) should be installed on the main air supply to the pump. This ensures that pressure is not generated by the pump when the controller is not operating. The air supply valve signal output on the CycleFlo controller is designed to control this valve.

An access hole with a strain relief installed has been provided for the external power connection. Due to the unique requirements of each installation, access holes have not been provided for other optional external wiring connections. Access holes will need to be added for the external Air Supply Valve Signal and/or Remote Run options. Have a qualified electrician determine the proper strain relief, wire type, and wire size for your particular application. When positioning or adding access holes, be careful not to damage any internal components. Failure to use the proper strain relief, wire type, and wire size can cause damage to internal components or personal injury.

The 24 Volt DC Air Supply Valve Signal output is used to control a three-way valve (Graco Part No. 115605 or equivalent) on the main air supply of pumps larger than the Husky 205. This ensures that pressure is not generated by the pump when the controller is not operating. Failure to use this valve can cause damage to the unit and possible personal injury.

⚠ WARNING

Failure to use the recommended valve can cause damage to the unit and possible personal injury. Follow the pressure relief procedure in the pump manual before moving or servicing the pump.

The CycleFlo requires 100–240 VAC, 50/60 Hz to operate. The power input is fuse-protected with a 750 mA fuse (see Fig. 2).

Electrical Connections

⚠ WARNING



FIRE, EXPLOSION, AND ELECTRIC SHOCK HAZARD

To reduce the risk of fire, explosion, or electric shock:



- The power source conduit is not an adequate ground for the system. The unit must be grounded to a true earth ground.
- A qualified electrician must complete all grounding and wiring connections and check the resistance.

- Refer to your local code for the requirements for a “true earth ground” in your area.

⚠ WARNING

When replacing the fuse, make sure to replace it only with one of equivalent rating. Failure to do so may cause damage to the unit and possible personal injury.

Connect power to the unit as described. Always have a qualified electrician perform wiring connections. Connect Line (L) and Neutral (N) wires to the terminal block as shown in Fig. 2. The Ground wire (GND) must be attached to the #10–32 ground stud. A crimp-on ground wire lug comes attached to the ground stud. Remove the lug and attach to the ground wire. Replace the lug assembly back onto the stud and fasten down with the kepsnut provided.

Installation

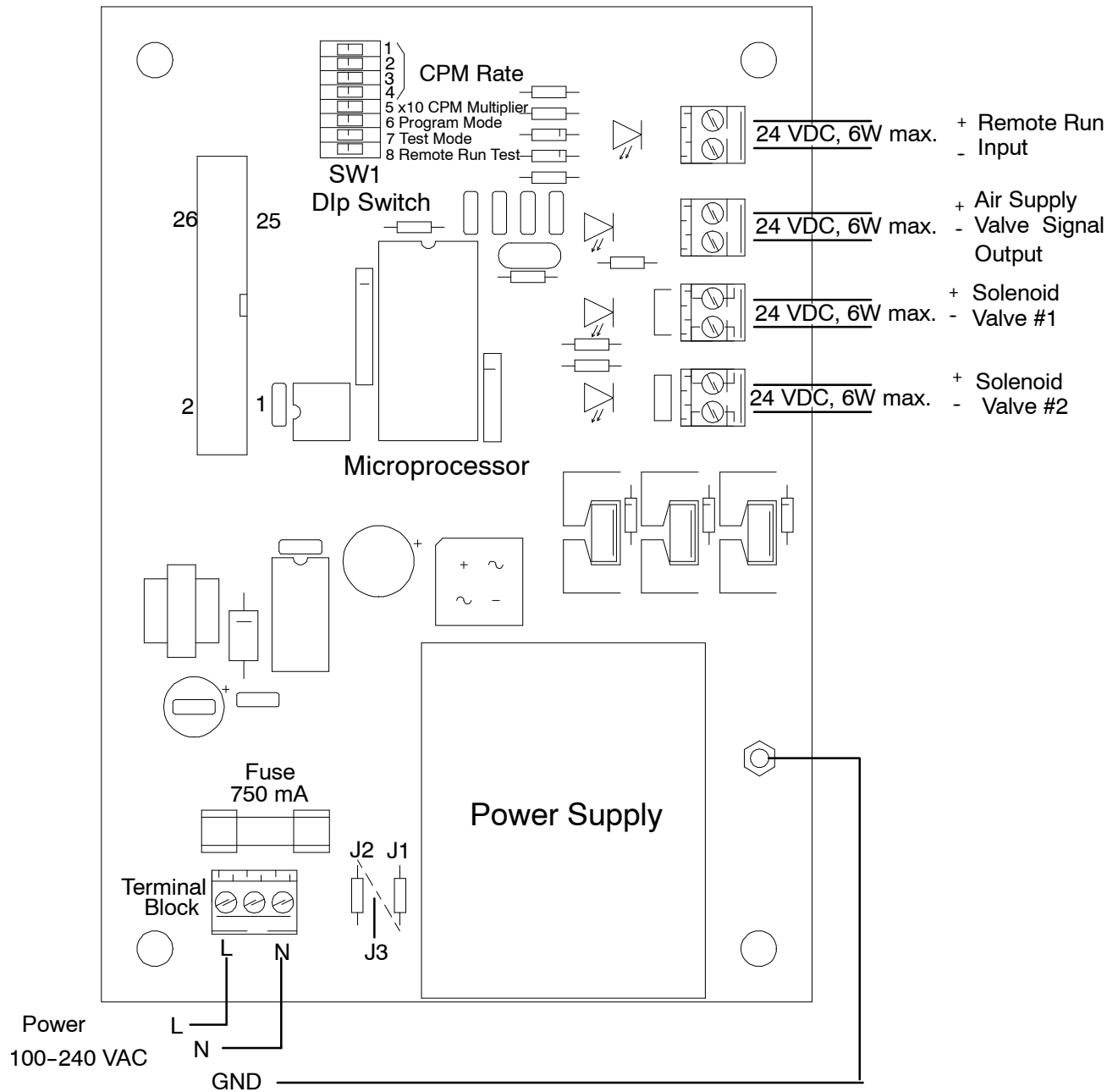

Fig. 2

The Remote Run input is an external switch input. A switch connected to this input should be a potential free contact.

Solenoid Valve #1 and #2 Signals (24 VDC output signals) are pre-connected to the air valves on the right side of the CycleFlo.

The Air Supply Line Valve Signal is a 24 VDC output signal. This signal drives the external 6W solenoid valve (Graco Part No. 115605), which controls the main air supply (required for pumps larger than the Husky 205).

Power Connections

Connect Line (L), Neutral (N), and Ground (GND) as shown in Fig. 2. Ground wire must be attached to the ground stud and fastened down with the nut provided.

Setup and Programming

An 8-position DIP switch (SW1) (see Fig. 1 for location) is used to set the cycle rate and cycles multiplier. It is also used to invoke the various test modes.

Before the CycleFlo can be put into operation, the parameters in Fig. 3 must be programmed for each particular application.

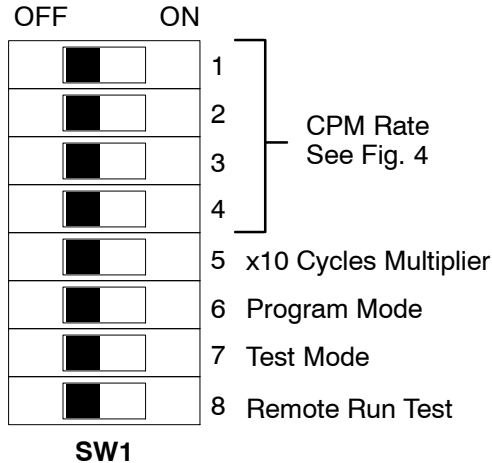

Fig. 3

Cycles Per Minute (CPM) Rate

The pump cycle rate is adjustable to accommodate different pump sizes, varying product viscosity, and product delivery speed. The pump cycle rate is measured in cycles per minute (CPM), which is the number of times the pump performs a pump cycle in one minute. One pump cycle consists of a momentary pressurization of each one of the two diaphragms.

The CPM Rate Table in Fig. 4 shows the settings for the first four switches of SW1 and the resulting CPM rate.

SW1 CPM Rate Table

CPM	10	15	20	25	30	35	40	45	50	62	75	88	100	125	150	200
1		●		●		●		●		●		●		●		●
2			●	●			●	●			●	●			●	●
3					●	●	●	●					●	●	●	●
4									●	●	●	●	●	●	●	●

● Denotes Switch is ON

Fig. 4

Presets

The CycleFlo has 32 programmable presets to easily switch between amounts of fluid delivered by the pump during a RUN cycle. Each preset is programmed with the number of times the pump will be cycled. Use the ▲ and ▼ buttons on the front panel to step through the presets. The PRESET display will indicate the selected PRESET program number and the CYCLES display will show the associated number of pump cycles.

NOTE: SW1-5 is the x10 Cycle Multiplier. If SW1-5 is in the ON position, the actual number of pump cycles will be 10 times that of the CYCLES display.

To change the number of cycles associated with a programmed preset, do the following:

1. Place the CycleFlo into Program Mode by moving SW1-6 to ON. The PRESET display will blink to indicate that the Program Mode is active.
2. Use the ▼▲ buttons to select the PRESET to be changed.
3. Press and hold the RUN button, then use the ▼ and ▲ buttons to adjust the 100's digit of the CYCLES display.
4. Press and hold the RESET button, then use the ▼ and ▲ buttons to adjust the 10's digit of the CYCLES display.
5. Press and hold the PRIME button, then use the ▼ and ▲ buttons to adjust the 1's digit of the CYCLES display.
6. Once the correct number of cycles is displayed, use the ▼ and ▲ buttons to move to another PRESET and then back to the current one to verify that the new cycle count was stored correctly.
7. Repeat for the next PRESET, as needed.
8. When finished, switch SW1-6 to the OFF position to place the CycleFlo into Normal Operating mode.

NOTE: Either the ▼ or ▲ button must be pressed for the new cycle count to be programmed into the CycleFlo's memory.

Operation

Priming the Pump

A priming feature allows for the temporary operation of the pump for priming purposes. The pump cycle rate during priming is controlled by the 8-position DIP switch (SW1).

Pressing the PRIME button on the front panel will start the pump cycling while the button is held. Once primed, release the button to stop pump operation.

Front Panel Operation

The ▼ and ▲ buttons (see Fig. 5) select the desired PRESET pump cycle. The pump cycle count for each PRESET is displayed in the CYCLES display.

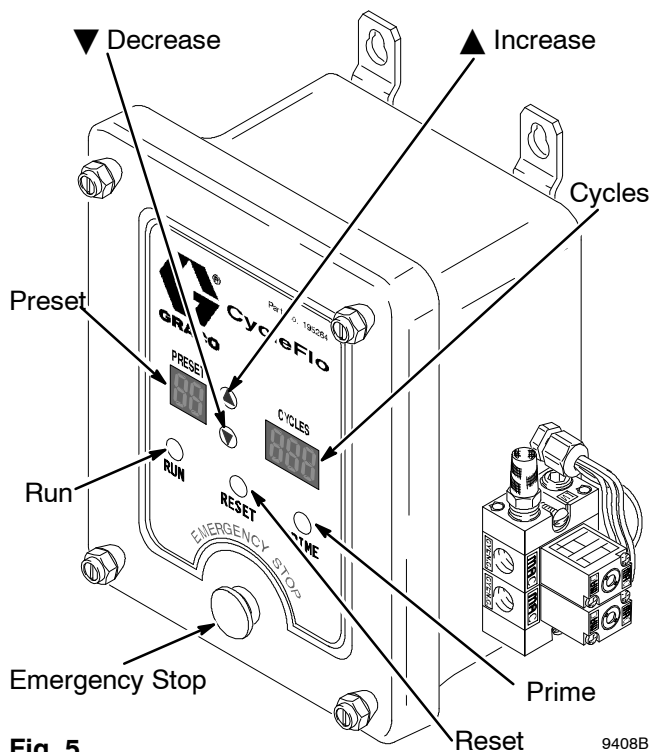

Pressing the RUN button on the front panel starts the pump cycling for the number of cycles indicated by the CYCLES display. The CYCLES display will count down from its current count every time the pump performs a complete cycle (both diaphragms alternately activated). When all cycles have been performed, the pump will stop and the CYCLES display will automatically be reset to the full cycle count for the current PRESET. The unit is then ready for another dispense cycle.

Pressing the RESET button during a RUN operation stops the pumping cycle. The CYCLES display will blink to indicate that the RUN mode was interrupted. Once in this mode, there are two possible actions: pressing the RUN button will resume the pump cycling where it was interrupted or pressing the RESET button again will reset the CYCLES to the full count for the current PRESET.

Remote Operation

The ▼ and ▲ buttons select the desired PRESET number of pump cycles. Pump cycles for each PRESET are displayed in the CYCLES display.

Closing the REMOTE RUN contact starts the pump cycling for the number of cycles indicated by the CYCLES display. The CYCLES display will count down from its current count every time the pump performs a complete cycle (both the diaphragms alternately activated). When all cycles have been performed, the pump will stop and the CYCLES display will automatically be reset to the full cycle count for the current RESET.

Opening the REMOTE RUN contact stops the pump cycling. The CYCLES display will blink to indicate that the RUN mode was interrupted. Once in this mode, there are two possible actions: closing the REMOTE RUN contact again will resume the pump cycling where it was interrupted or pressing the RESET button on the front panel will reset the CYCLES to the full count for the current PRESET.

When all cycles have been performed, the pump will stop and the CYCLES display will show 000 until the REMOTE RUN contact is opened. The CYCLES display will then automatically be reset to the full cycle count for the current PRESET.

Troubleshooting

The following is a list of possible problems and their causes. The CycleFlo also has a built-in self-test mode that allows dynamic testing of all components.

Troubleshooting Guide

Problem	Cause	Solution
No operation at all	Blown fuse.	Check fuse and replace with 250 V 750 mA type.
	Emergency Stop switch OFF.	Press switch.
LED display shows incomplete digits	Poor ribbon cable connection.	Turn power off and unplug then re-plug ribbon cable on main board and display board.
	Damaged display board.	Replace board.
Front panel button(s) don't work	Poor ribbon cable connection.	Turn power off and unplug then re-plug ribbon cable on main board and display board.
	Loose mounting screw.	Make sure mounting screws on display board are securely tightened.
	Damaged display board.	Replace board.
Pump won't operate when RUN button is pressed	Incorrect operating mode.	Make sure SW1-6, 7, 8 are all in the OFF position.
	No or low air supply.	Check air supply to make sure there is sufficient pressure and air available.
Pump won't operate (cycles count down and valve driver LED's blink)	Bad solenoid wire connections.	Turn off power and check wire connections from solenoid valve #1 and #2 to make sure they are all connected and seated properly.
	Bad solenoid valve(s).	Turn off air supply and listen for "clicking" on solenoid valves; replace valves if no "clicking" is audible.
Pump won't operate (CYCLES count down but no valve driver LED's)	Bad valve drivers on main board.	Replace main board.

Self-Test Mode

CAUTION

During this test, the solenoid valves may be activated. This will activate a connected pump. To prevent inadvertent pumping, disconnect the air supply to the solenoid valves or remove the air lines to the pump.

TEST MODE (SW1-7)

The CycleFlo has a built-in test program that allows for dynamic testing of all internal and external components.

Once activated, the self-test mode will do the following continuously until the test mode is de-activated:

- All display digits count from 0-9 in unison. This is used to determine if any of the displays are faulty. Replace the display board if segments of the display fail to activate during the self-test.

- Each of the five front panel buttons activates a decimal point on the LED displays. Replace the display board if a button fails to activate a decimal point.

Position SW1-7 to the ON position to activate the self-test mode. Position SW1-7 to the OFF position to de-activate the self-test mode.

REMOTE RUN TEST (SW1-8)

Position SW1-8 (the REMOTE RUN test) to the ON position to activate the AIR SUPPLY VALVE signal and cycle the solenoid valves at the CPM rate set by SW1-1, 2, 3, 4. The Remote Run Test (SW1-8) performs the same function as closing the Remote Run Switch input, and therefore, is used to test the functionality of the Remote Run Switch input. Follow the **Troubleshooting Guide** on page 10 if either fails to operate.

Parts

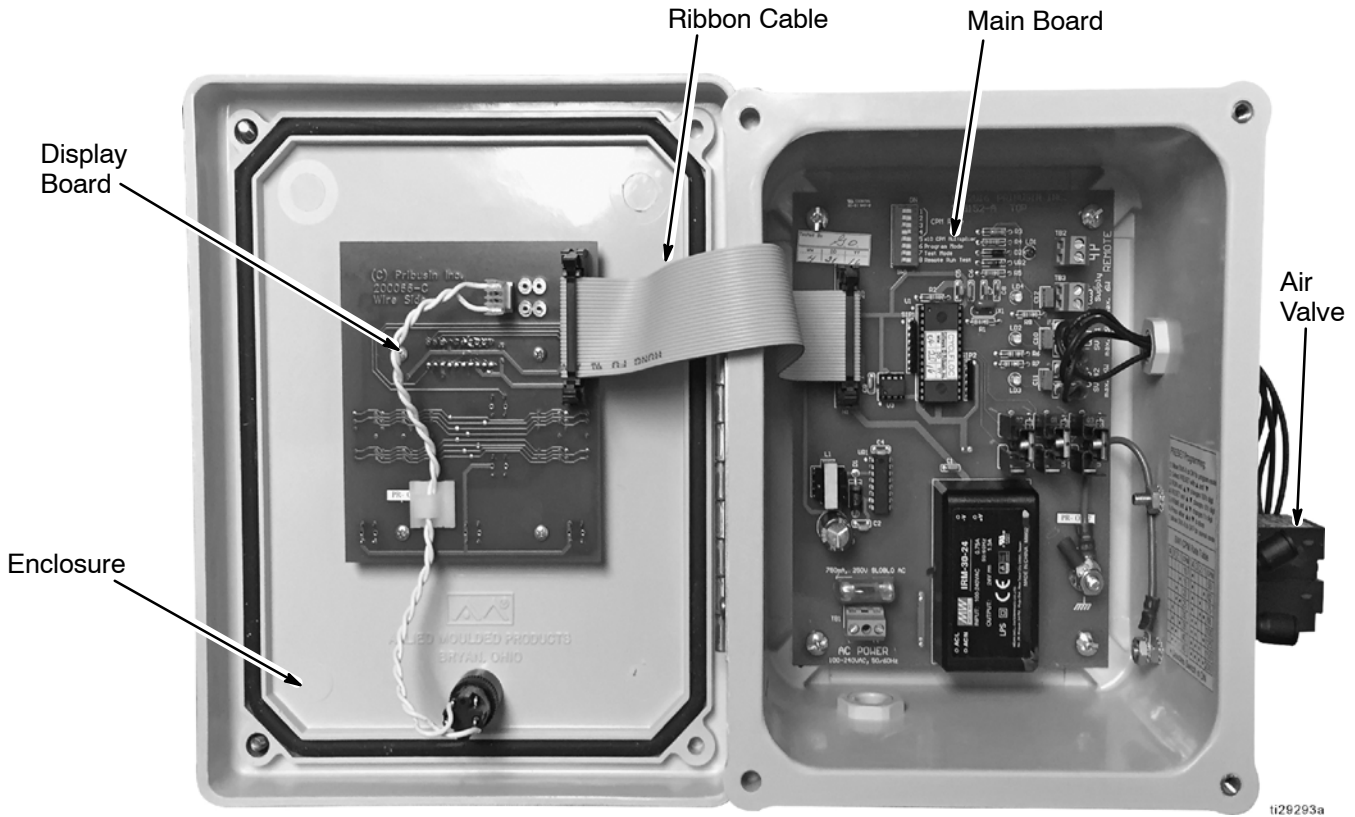

Parts

Part No.	Description
195264	CycleFlo Pneumatic Pump Controller Unit (120 VAC)
-----	Enclosure
-----	Emblem (not shown - located on front of unit) (120 VAC)
-----	Emblem (not shown - located on front of unit) (240 VAC)
115381	Main Board
115380	Display Board
115382	Ribbon Cable
115383	Air Valve (NOTE: two valves are required per controller)

Optional Accessories

Part No.	Description
102518	Cord Set, Electrical
115988	Tube, Nylon, 50 ft
115605	Valve, Solenoid, 24 VDC, 6W

----- Not sold separately.

Typical Installation Diagrams

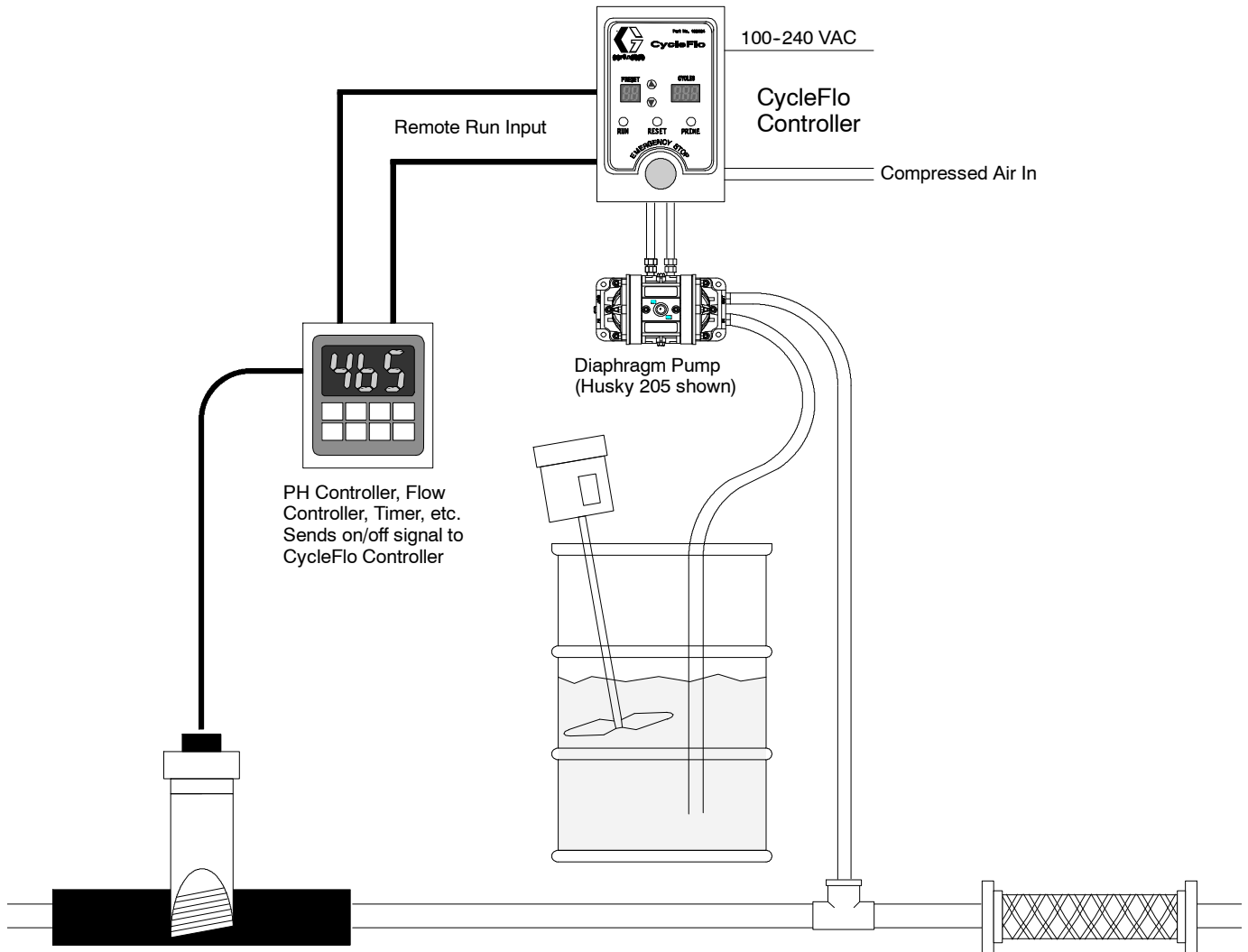

9409A

Typical Installation Diagrams

CycleFlo Controller

Chemical Injector

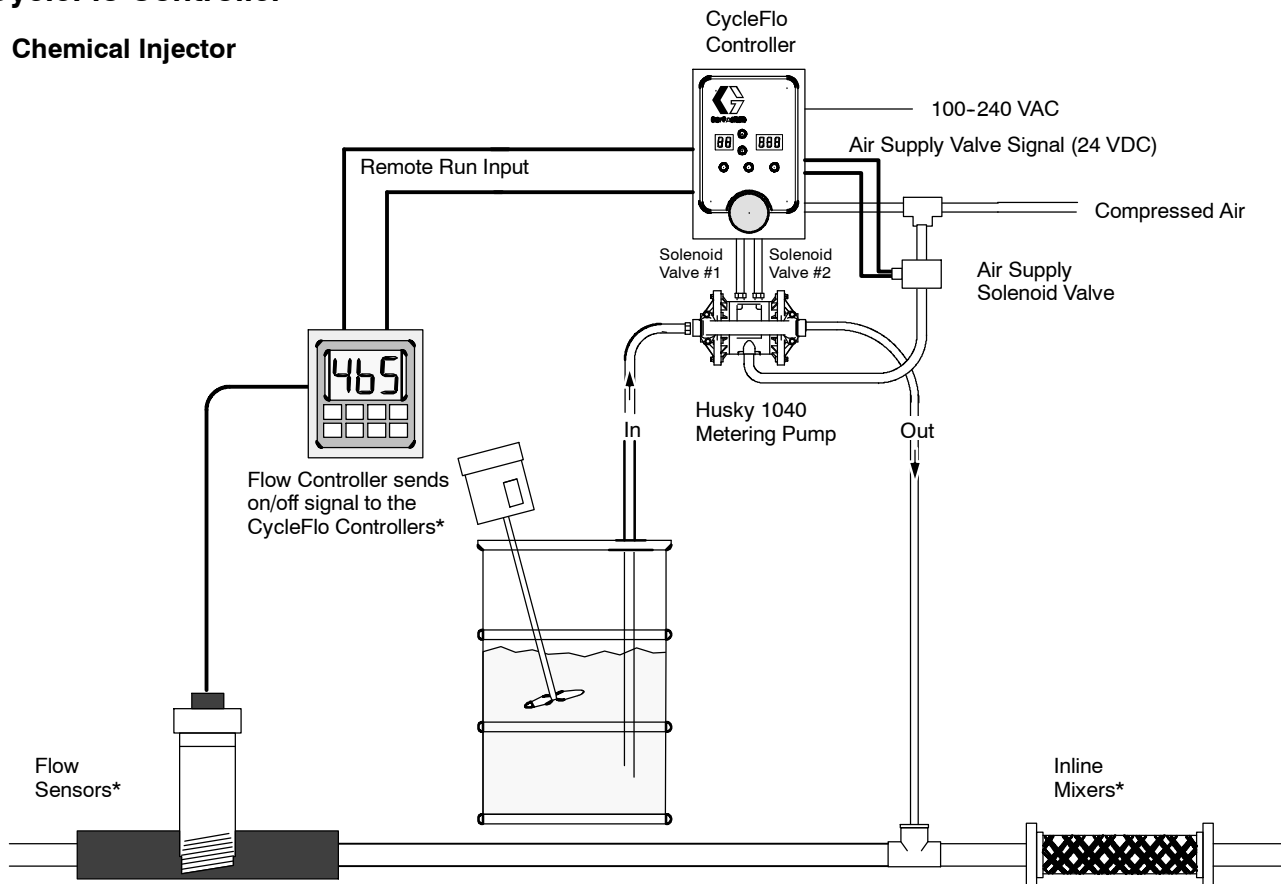

*Provided by others

Typical Installation Diagrams

CycleFlo Controller

Water Neutralization

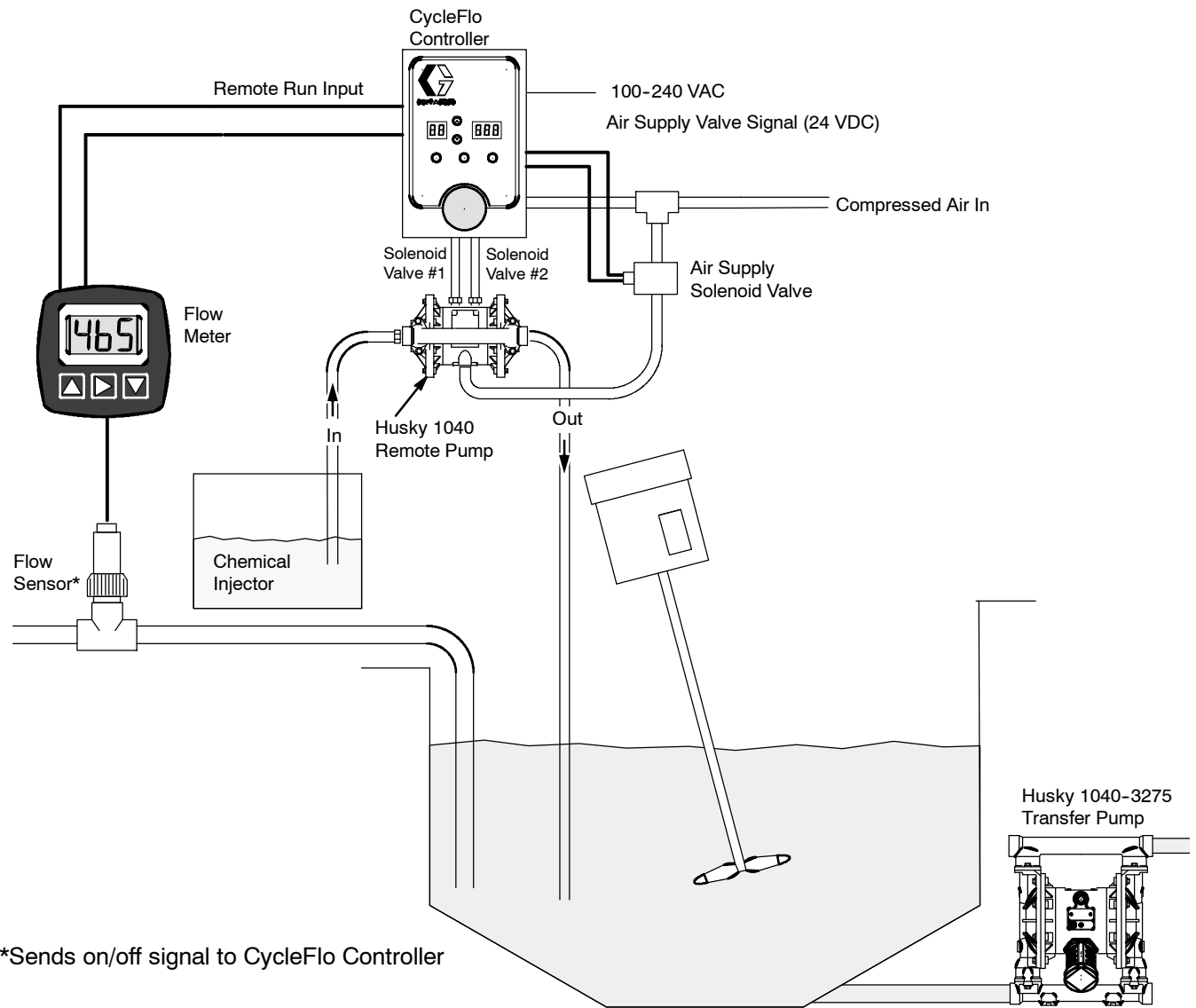

Typical Installation Diagrams

CycleFlo Controller Water Treatment

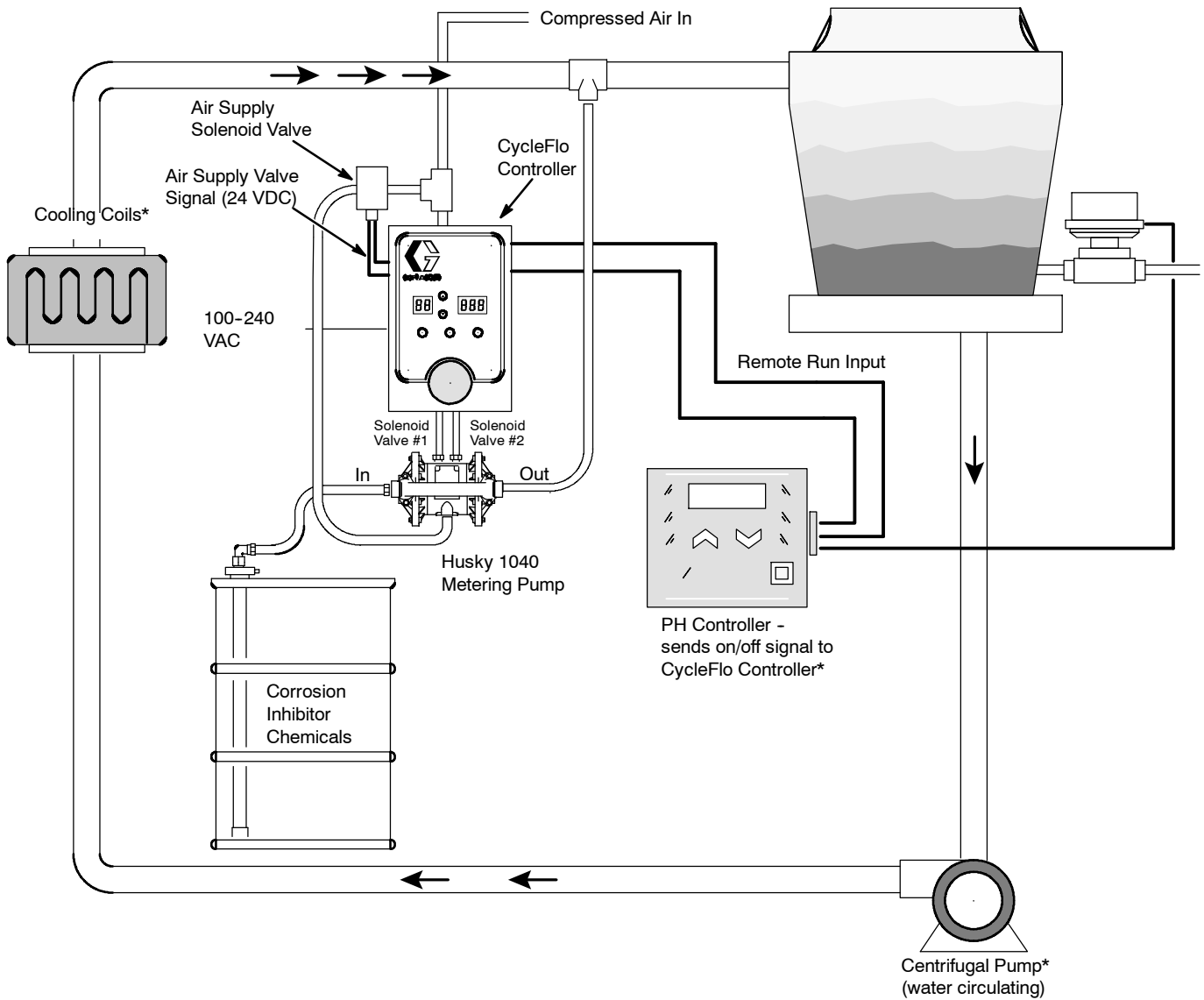

* Provided by others

Specifications

Power Requirements:

100–240 VAC, 50/60 Hz, 750 mA

Air Supply:

120 psi (0.8 MPa, 8 bar) Maximum

Mounting Information

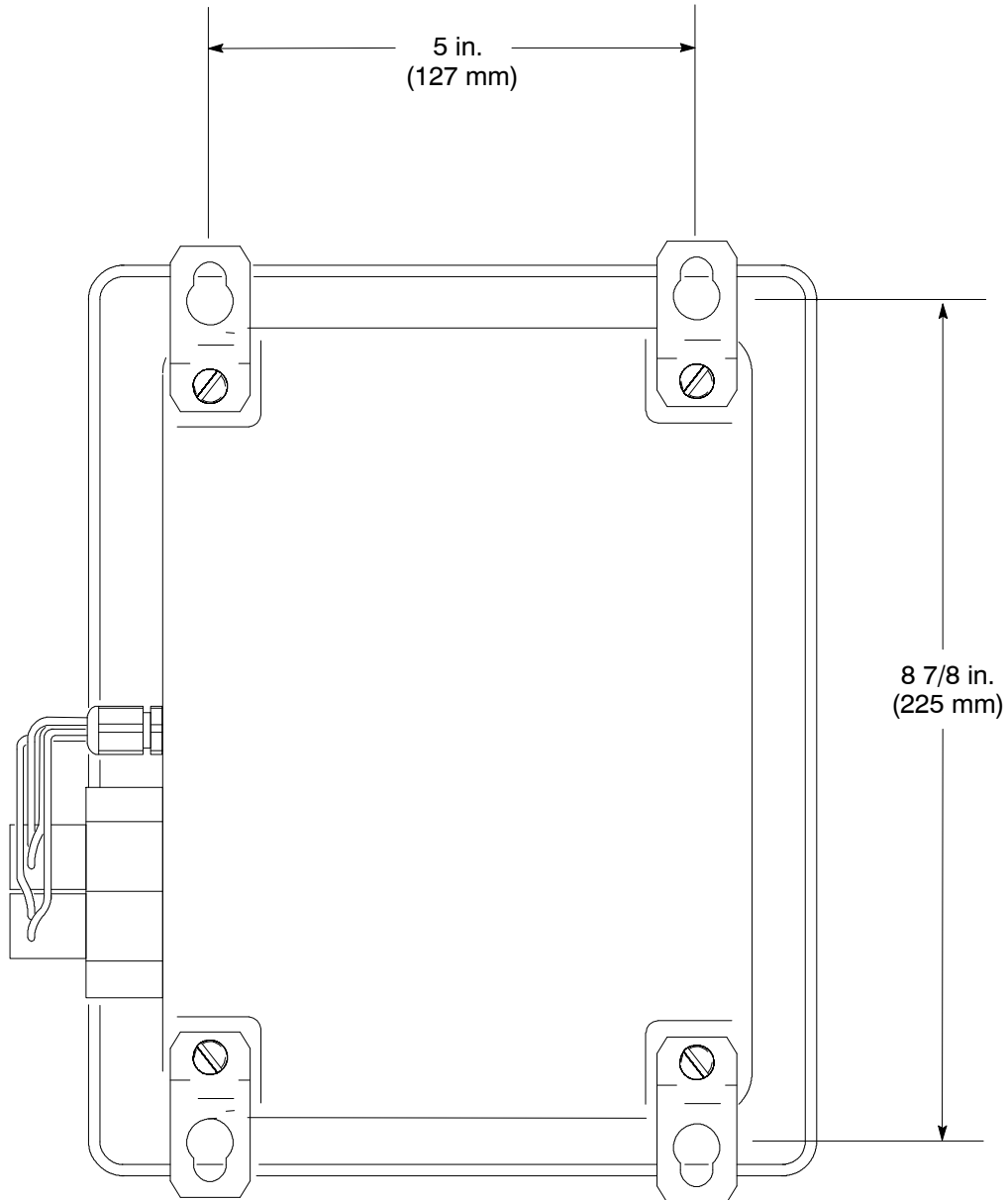

9438A

Graco Standard Warranty

Graco warrants all equipment manufactured by Graco and bearing its name to be free from defects in material and workmanship on the date of sale by an authorized Graco distributor to the original purchaser for use. With the exception of any special, extended, or limited warranty published by Graco, Graco will, for a period of twelve months from the date of sale, repair or replace any part of the equipment determined by Graco to be defective. This warranty applies only when the equipment is installed, operated and maintained in accordance with Graco's written recommendations.

This warranty does not cover, and Graco shall not be liable for general wear and tear, or any malfunction, damage or wear caused by faulty installation, misapplication, abrasion, corrosion, inadequate or improper maintenance, negligence, accident, tampering, or substitution of non-Graco component parts. Nor shall Graco be liable for malfunction, damage or wear caused by the incompatibility of Graco equipment with structures, accessories, equipment or materials not supplied by Graco, or the improper design, manufacture, installation, operation or maintenance of structures, accessories, equipment or materials not supplied by Graco.

This warranty is conditioned upon the prepaid return of the equipment claimed to be defective to an authorized Graco distributor for verification of the claimed defect. If the claimed defect is verified, Graco will repair or replace free of charge any defective parts. The equipment will be returned to the original purchaser transportation prepaid. If inspection of the equipment does not disclose any defect in material or workmanship, repairs will be made at a reasonable charge, which charges may include the costs of parts, labor, and transportation.

THIS WARRANTY IS EXCLUSIVE, AND IS IN LIEU OF ANY OTHER WARRANTIES, EXPRESS OR IMPLIED, INCLUDING BUT NOT LIMITED TO WARRANTY OF MERCHANTABILITY OR WARRANTY OF FITNESS FOR A PARTICULAR PURPOSE.

Graco's sole obligation and buyer's sole remedy for any breach of warranty shall be as set forth above. The buyer agrees that no other remedy (including, but not limited to, incidental or consequential damages for lost profits, lost sales, injury to person or property, or any other incidental or consequential loss) shall be available. Any action for breach of warranty must be brought within two (2) years of the date of sale.

Graco makes no warranty, and disclaims all implied warranties of merchantability and fitness for a particular purpose in connection with accessories, equipment, materials or components sold but not manufactured by Graco. These items sold, but not manufactured by Graco (such as electric motors, switches, hose, etc.), are subject to the warranty, if any, of their manufacturer. Graco will provide purchaser with reasonable assistance in making any claim for breach of these warranties.

In no event will Graco be liable for indirect, incidental, special or consequential damages resulting from Graco supplying equipment hereunder, or the furnishing, performance, or use of any products or other goods sold hereto, whether due to a breach of contract, breach of warranty, the negligence of Graco, or otherwise.

FOR GRACO CANADA CUSTOMERS

The parties acknowledge that they have required that the present document, as well as all documents, notices and legal proceedings entered into, given or instituted pursuant hereto or relating directly or indirectly hereto, be drawn up in English. Les parties reconnaissent avoir convenu que la rédaction du présente document sera en Anglais, ainsi que tous documents, avis et procédures judiciaires exécutés, donnés ou intentés à la suite de ou en rapport, directement ou indirectement, avec les procédures concernées.

Graco Information

For the latest information about Graco products, visit www.graco.com.

TO PLACE AN ORDER, contact your Graco distributor, or call to identify the distributor closest to you:

Phone: 612-623-6921 **or Toll Free:** 1-800-328-0211 **Fax:** 612-378-3505

All written and visual data contained in this document reflects the latest product information available at the time of publication. Graco reserves the right to make changes at any time without notice.

Original instructions. This manual contains English. MM 309003

Graco Headquarters: Minneapolis
International Offices: Belgium, China, Japan, Korea

GRACO INC. AND SUBSIDIARIES • P.O. BOX 1441 • MINNEAPOLIS MN 55440-1441 • USA
Copyright 1999, Graco Inc. All Graco manufacturing locations are registered to ISO 9001.

www.graco.com

Revision H, September 2018