

Instructions

Electric Grease Jockey

Automatic Lubrication

System



3A5082E

EN

***For dispensing of NLGI Grades #000 to #2 greases. For Professional Use Only.
Not approved for use in explosive atmospheres or hazardous locations.***

2000 psi (13.79 MPa, 137.9 bar)



Important Safety Instructions

Read all warnings and instructions in this manual. Save all instructions.

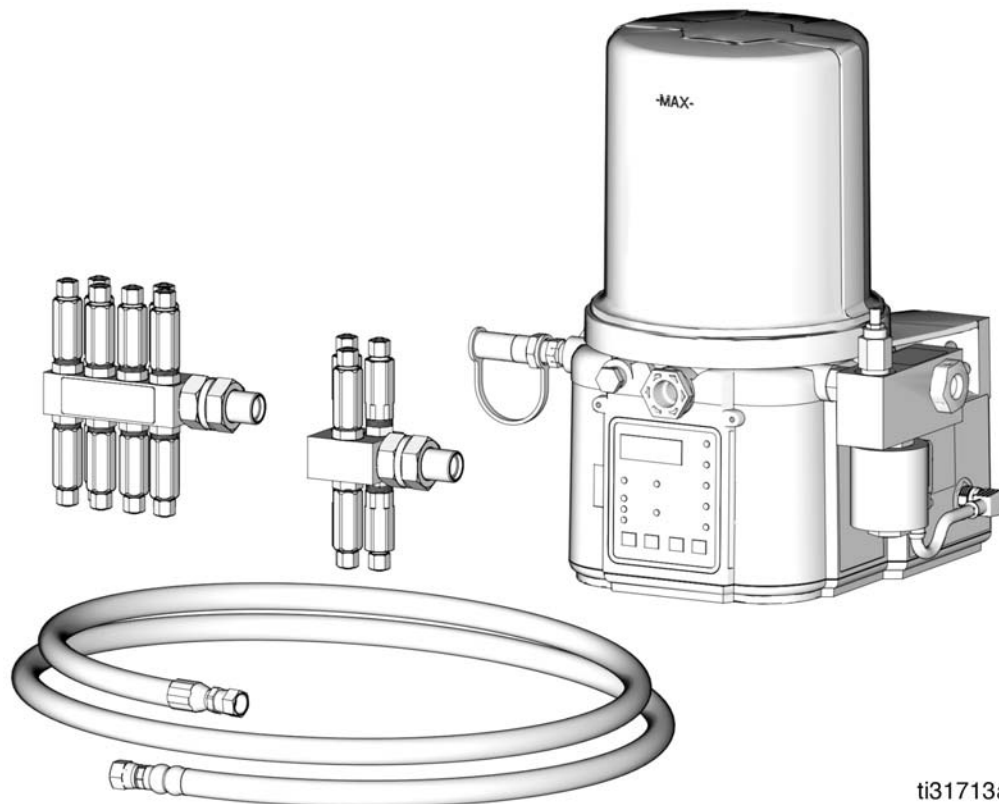

ti31713a







Contents

Contents

| | | | |
|---|-----------|--|-----------|
| Warnings | 3 | Injectors | 44 |
| Before You Start | 5 | Parts | 44 |
| System Overview | 5 | Injector Dimensions | 44 |
| Typical System Installation | 6 | Adjusting Grease Output Volume | 45 |
| Pump | 8 | Manifold Installation | 46 |
| Component Identification | 8 | Modules | 47 |
| Parts: 24Z660, 24Z958, 24Z764, 24Z959 | 9 | Feed Line Tubes and Fittings | 54 |
| Parts: 24Z660, 24Z958, 24Z764, 24Z959 | 10 | Feed Line Tubes (H) | 54 |
| Pump Dimensions | 11 | Feed Line Installation | 54 |
| Choosing an Installation Location | 12 | Feed Line Fittings | 55 |
| Low Level Fault/Warning | 15 | Main Line Hose | 56 |
| Fuses | 15 | Determining Main Line Hose Lengths | 56 |
| Pump Over-Current Protection | 15 | Main Line Hose Assembly | 57 |
| Illuminated Remote Run Button | 16 | Main Line Fittings | 58 |
| Tri-Color Remote Illumination | 17 | System Starting and Operation | 59 |
| Direct Mount Vent Valve | 17 | System Starting | 59 |
| Pump Setup | 18 | Operation | 59 |
| Priming | 19 | Troubleshooting | 61 |
| Programming the Pump | 20 | Maintenance | 64 |
| Quick Setup Guide - | | Technical Specifications | 65 |
| DMS and Illuminated Remote Run Models | 21 | Notes | 67 |
| Pump Software | 21 | Graco Standard Warranty | 68 |
| PUMP OFF / REST Setup | 24 | Graco Information | 68 |
| DMS™ Models | 25 | | |
| Error Log | 28 | | |
| Functional Summary | 30 | | |
| Technical Summary | 31 | | |
| Advanced Programming | 32 | | |
| Time Control | 34 | | |
| Alarms | 36 | | |
| Fault / Warning Scenarios | 36 | | |
| Fault/Warning Scenarios for Firmware | | | |
| Versions 5.06 and Later for Non-DMS Models | | | |
| and 7.09 and later for DMS Models | 40 | | |
| Testing Installation | 41 | | |
| Manual Run Cycle | 41 | | |
| Manifold | 42 | | |
| Parts: 6 port models | 42 | | |
| Parts: 12 port models | 42 | | |
| Manifold Dimensions | 43 | | |
| Injector Manifold Assembly | 43 | | |





Warnings

The following warnings are for the setup, use, grounding, maintenance, and repair of this equipment. The exclamation point symbol alerts you to a general warning and the hazard symbols refer to procedure-specific risks. When these symbols appear in the body of this manual or on warning labels, refer back to these Warnings. Product-specific hazard symbols and warnings not covered in this section may appear throughout the body of this manual where applicable.

|  <h1 style="margin: 0;">WARNING</h1> | |
|---|--|
|   | <p>EQUIPMENT MISUSE HAZARD</p> <p>Misuse can cause death or serious injury.</p> <ul style="list-style-type: none"> Do not operate the unit when fatigued or under the influence of drugs or alcohol. Do not exceed the maximum working pressure or temperature rating of the lowest rated system component. See Technical Specifications in all equipment manuals. Use fluids and solvents that are compatible with equipment wetted parts. See Technical Specifications in all equipment manuals. Read fluid and solvent manufacturer's warnings. For complete information about your material, request Safety Data Sheets (SDSs) from distributor or retailer. Turn off all equipment and follow the Pressure Relief Procedure when equipment is not in use. Check equipment daily. Repair or replace worn or damaged parts immediately with genuine manufacturer's replacement parts only. Do not alter or modify equipment. Alterations or modifications may void agency approvals and create safety hazards. Make sure all equipment is rated and approved for the environment in which you are using it. Use equipment only for its intended purpose. Call your distributor for information. Route hoses and cables away from traffic areas, sharp edges, moving parts, and hot surfaces. Do not kink or over bend hoses or use hoses to pull equipment. Keep children and animals away from work area. Comply with all applicable safety regulations. |
|    | <p>SKIN INJECTION HAZARD</p> <p>High-pressure fluid from dispensing device, hose leaks, or ruptured components will pierce skin. This may look like just a cut, but it is a serious injury that can result in amputation. Get immediate surgical treatment.</p> <ul style="list-style-type: none"> Do not point dispensing device at anyone or at any part of the body. Do not put your hand over the fluid outlet. Do not stop or deflect leaks with your hand, body, glove, or rag. Follow the Pressure Relief Procedure when you stop dispensing and before cleaning, checking, or servicing equipment. Tighten all fluid connections before operating the equipment. Check hoses and couplings daily. Replace worn or damaged parts immediately. |
|  | <p>PLASTIC PARTS CLEANING SOLVENT HAZARD</p> <p>Many cleaning solvents can degrade plastic parts and cause them to fail, which could cause serious injury or property damage.</p> <ul style="list-style-type: none"> Use only compatible solvents to clean plastic structural or pressure-containing parts. See Technical Specifications in all equipment manuals for materials of construction. Consult the solvent manufacturer for information and recommendations about compatibility. |

Warnings

WARNING

| | |
|--|--|
|   | <p>PRESSURIZED EQUIPMENT HAZARD</p> <p>Over-pressurization can result in equipment rupture and serious injury.</p> <ul style="list-style-type: none">• A pressure relief valve is required at each pump outlet.• Follow Pressure Relief Procedure in this manual before servicing. |
|   | <p>MOVING PARTS HAZARD</p> <p>Moving parts can pinch, cut or amputate fingers and other body parts.</p> <ul style="list-style-type: none">• Keep clear of moving parts.• Do not operate equipment with protective guards or covers removed.• Pressurized equipment can start without warning. Before checking, moving, or servicing equipment, follow the Pressure Relief Procedure and disconnect all power sources. |
|  | <p>PERSONAL PROTECTIVE EQUIPMENT</p> <p>Wear appropriate protective equipment when in the work area to help prevent serious injury, including eye injury, hearing loss, inhalation of toxic fumes, and burns. This protective equipment includes but is not limited to:</p> <ul style="list-style-type: none">• Protective eyewear, and hearing protection.• Respirators, protective clothing, and gloves as recommended by the fluid and solvent manufacturer |

Before You Start

Grease Fittings

- Lubricate all grease fittings using a grease gun and verify that every grease point is accepting grease.
- Use a clean cloth or rag to remove any remaining grease, contaminants or dirt from the area around the passage way to the grease points.
- Remove grease fittings and extensions and install appropriate feed line fitting.

System Overview

The Electric Grease Jockey Automatic Lubrication System includes the following components. Numbers and letters used in these instructions refer to the Typical System Installation, page 6, and the component pages listed below.

- Electric Grease Jockey Pump, page 8
- Illuminated Remote Run Button, page 16
- Direct Mount Vent Valve, page 17
- Manifold, page 42
- Injectors, page 44
- Lubrication Modules, page 47
- Feed Line Tubes and Fittings, page 54
- Main Line Hose, page 56

Pressure Relief Procedure



Follow the Pressure Relief Procedure whenever you see this symbol.



This equipment stays pressurized until pressure is manually relieved. To help prevent serious injury from pressurized fluid, such as skin injection, splashing fluid and moving parts, follow the Pressure Relief Procedure when you stop dispensing and before cleaning, checking, or servicing the equipment.

Relieve pressure in system using two wrenches working in opposite directions on the banjo bolt (A) and outlet fitting to **slowly loosen fitting only** until fitting is loose and no more lubricant or air is leaking from fitting.

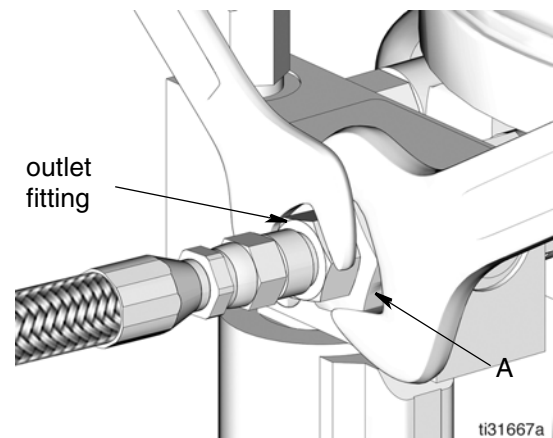

FIG. 1

Typical System Installation

Typical System Installation

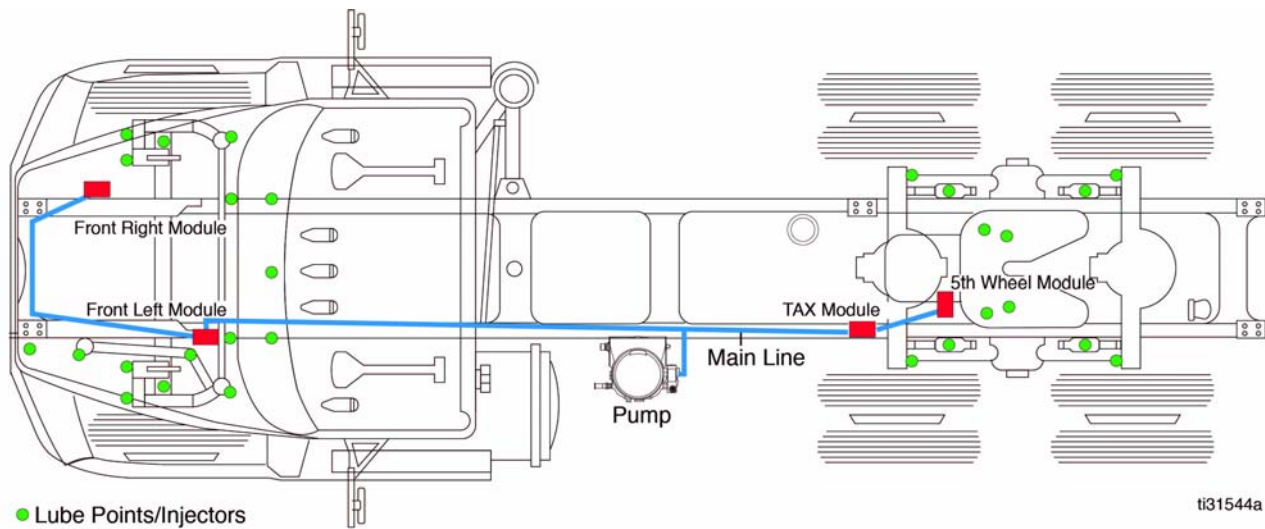

FIG. 2

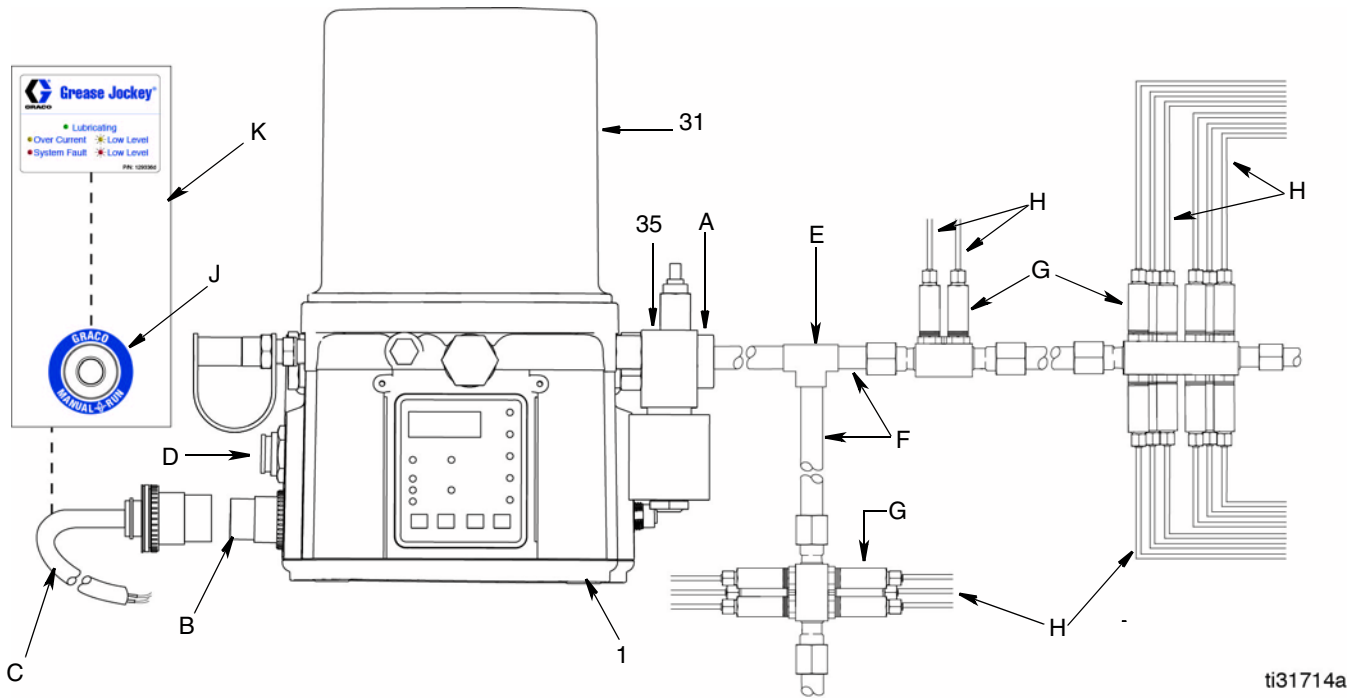

FIG. 3

Key:

- | | |
|--|--|
| A Banjo Bolt / Pump Outlet | J Manual Run Button (located in truck cab) |
| B Power Connector | K Instruction Label (located in truck cab) |
| C Power Cable/Remote Run Button Cable | |
| D USB Port (DMS™ Models only) | |
| E T-Fitting - Pump to Main Feed Hose (M) | |
| F Main Feed Hose | |
| G Injectors / Modules | |
| H Feed Line Tubes | |
| | 1 Pump |
| | 31 Reservoir |
| | 35 Vent Valve Assembly |

Typical System Installation

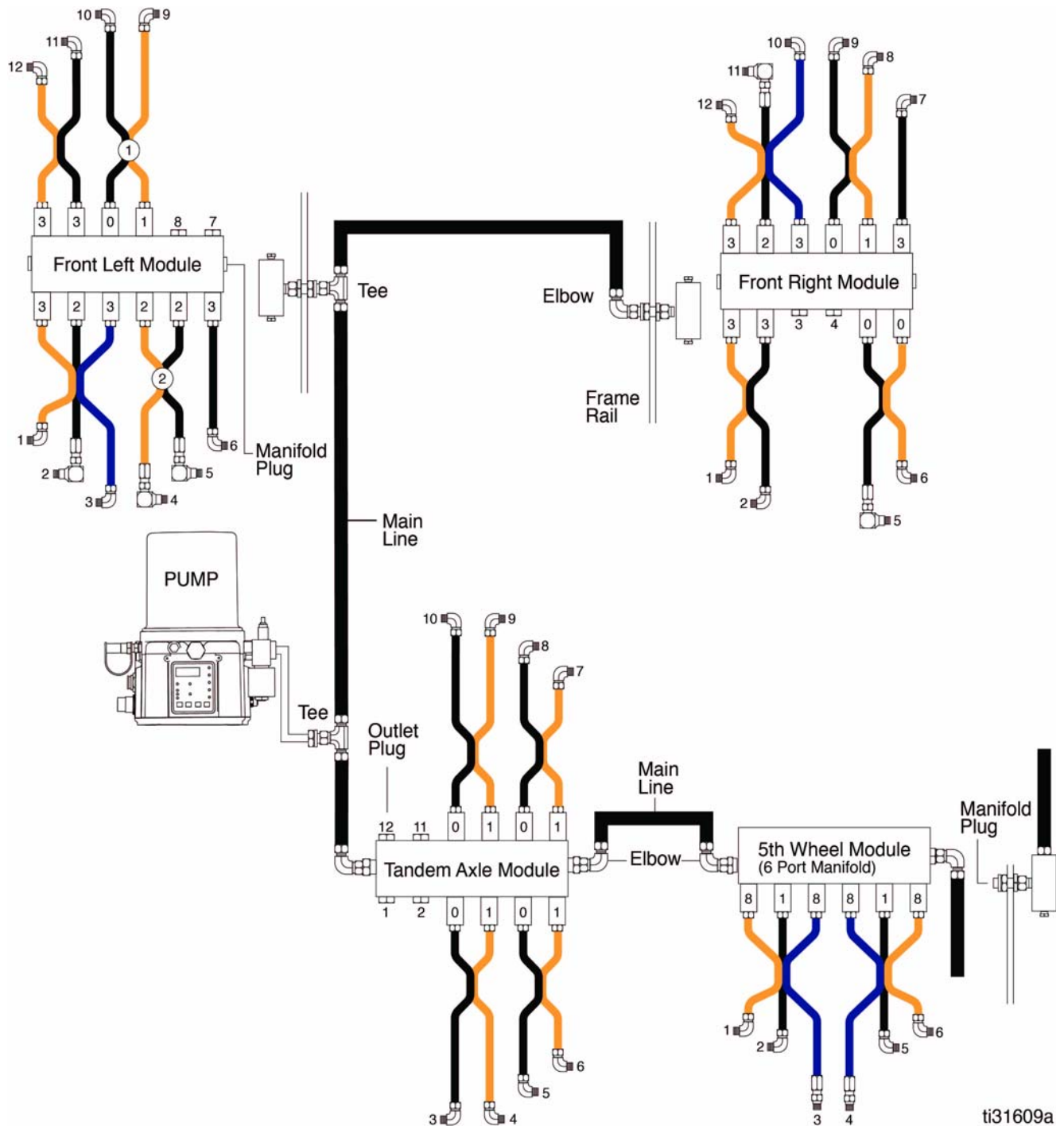

FIG. 4

Pump

Pump

Part No:

24Z764 - 12 Volt Standard

24Z959 - 24 Volt Standard

24Z660 - 12 Volt, DMS and Illuminated Remote Run Button

24Z958 - 24 Volt, DMS and Illuminated Remote Run Button

Component Identification

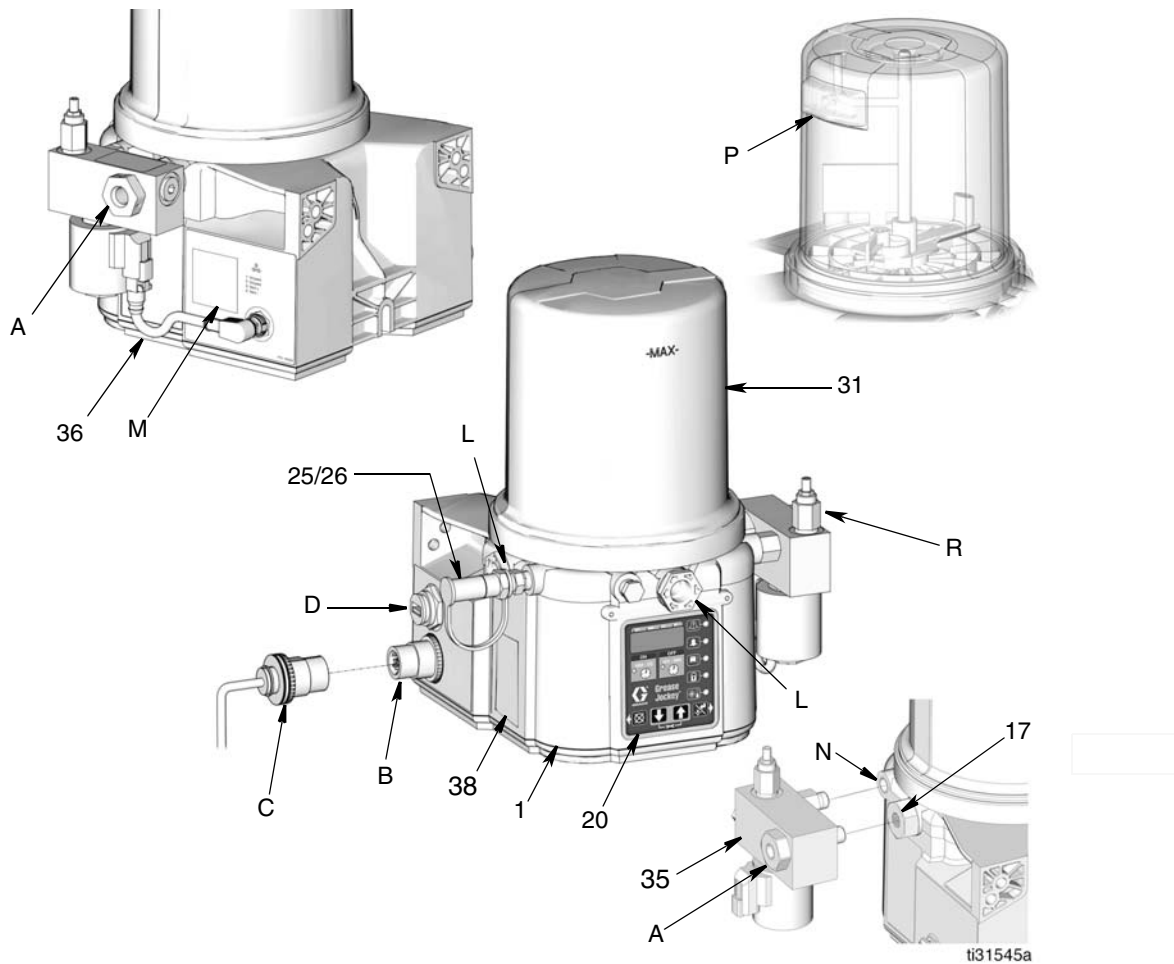

FIG. 5:

Key:

- | | |
|---|--|
| A Banjo Bolt / Pump Outlet | 1 Pump |
| B CPC Power Connector | 17 Pump Element (1 included. Can accommodate 3 total.) |
| C Power Cable/Remote Run Button Cable (required, sold separately) | 20 Control Panel |
| D USB Port (DMS™ Models only) | 25 Inlet Fill Fitting (fill port) |
| L Pump Outlet Plug | 26 Dust Cap |
| M Part No. Label | 31 Reservoir |
| N Vent Hole | 35 Vent Valve Assembly |
| P Air Vent for Reservoir | 36 Vent Valve Cable |
| R Relief Valve | 38 Safety Label, Pressure Warning |

Parts: 24Z660, 24Z958, 24Z764, 24Z959

| REF | Part No. | Description | Qty |
|-----|----------|----------------------------------|-----|
| 1 | | BASE, with control | 1 |
| 3 | 278142 | COVER, bottom, w/seal | 1 |
| 4 | 115477 | SCREW, mach, orx pan hd | 9 |
| 13❖ | 124396 | O-RING, 258, BUNA-N, green | 1 |
| 14 | | PLATE, ricer | 1 |
| 15 | | BEARING, ball | 1 |
| 17 | 25C987 | PUMP, element | 1 |
| 20† | 24T872 | BOARD, circuit, standard models | 1 |
| 20† | 262463 | BOARD, circuit, DMS models | 1 |
| 21 | 119228 | SCREW, mach, flat hd | 2 |
| 25 | 557874 | STUD, fill 1/4 NPTF female | 1 |
| 26 | 557875 | CAP, dust 3/4 | 1 |
| 28 | 129379 | LABEL, overlay | 1 |
| 30❖ | 127079 | PACKING, Rect-ring, 258 BUNA-N | 1 |
| 31❖ | 571149 | RESERVOIR, 2 liter | 1 |
| 32 | 24P108 | PLATE, wiper arm follow | 1 |
| 32a | | PADDLE, low level | 1 |
| 32b | | PADDLE, stirring | 1 |
| 32c | | WIPER, stirring | 1 |
| 32d | | SCREW, M6 | 1 |
| 32e | | WASHER | 2 |
| 33◆ | 24D838 | BAFFLE, low level, 2L | 1 |
| 34 | 117156 | BEARING, sleeve | 1 |
| 35 | 25C965 | VALVE, VENT, 12 VDC, DEU, N.O. | 1 |
| | 25C966 | VALVE, VENT, 24 VDC, DEU, N.O. | 1 |
| 36 | 129801 | CABLE, M12 X DEUTSCH | 1 |
| 38▲ | 16A579 | LABEL, safety, warning, pressure | 2 |

❖ Included in Kit 571042

† Also order Screw (21) and Label (28).

◆ Also order Bearing Sleeve (34)

▲ Replacement Danger and Warning labels, tags and cards are available at no cost.

Pump

Parts: 24Z660, 24Z958, 24Z764, 24Z959

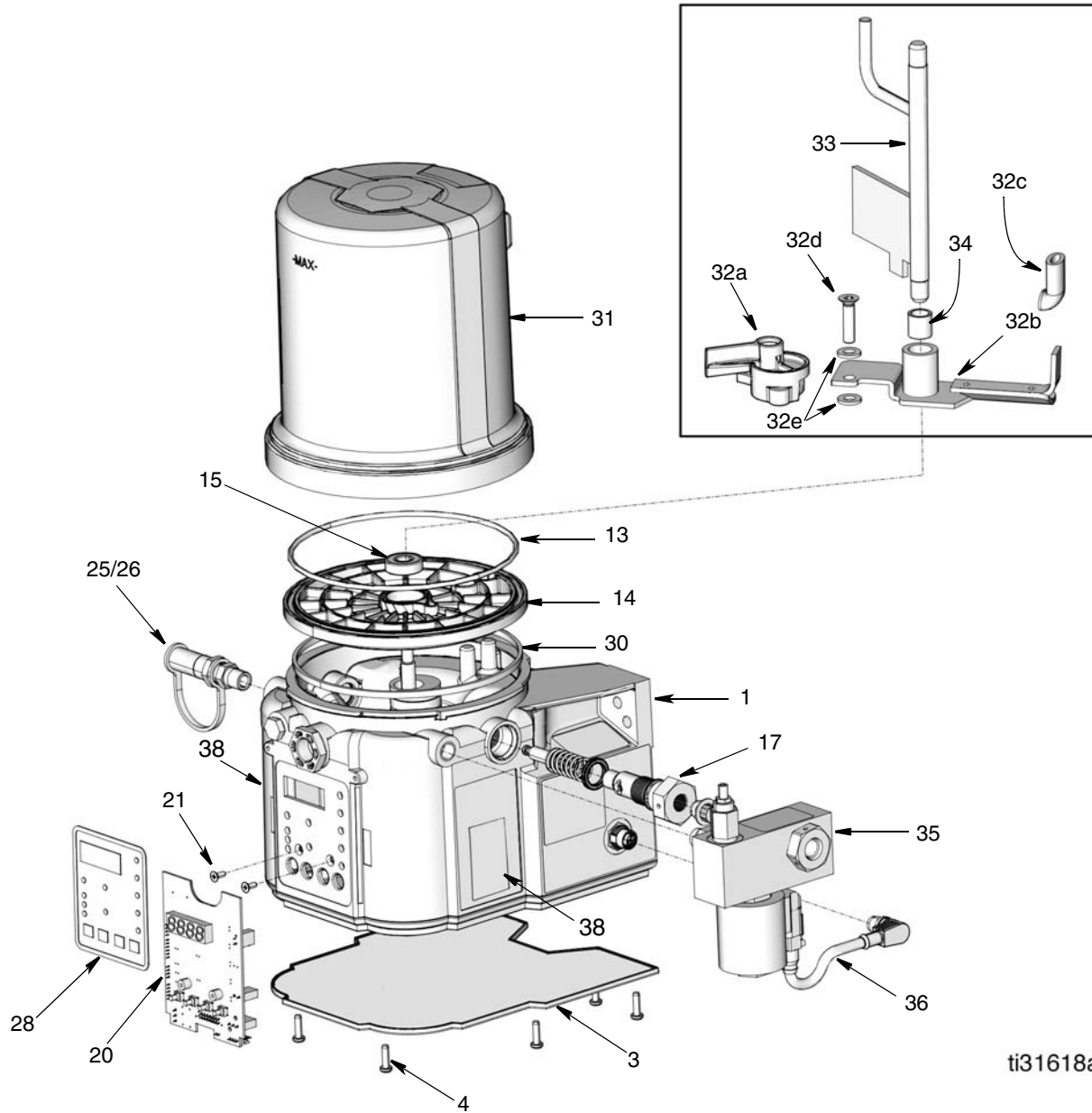

ti31618a

FIG. 6

Pump Dimensions

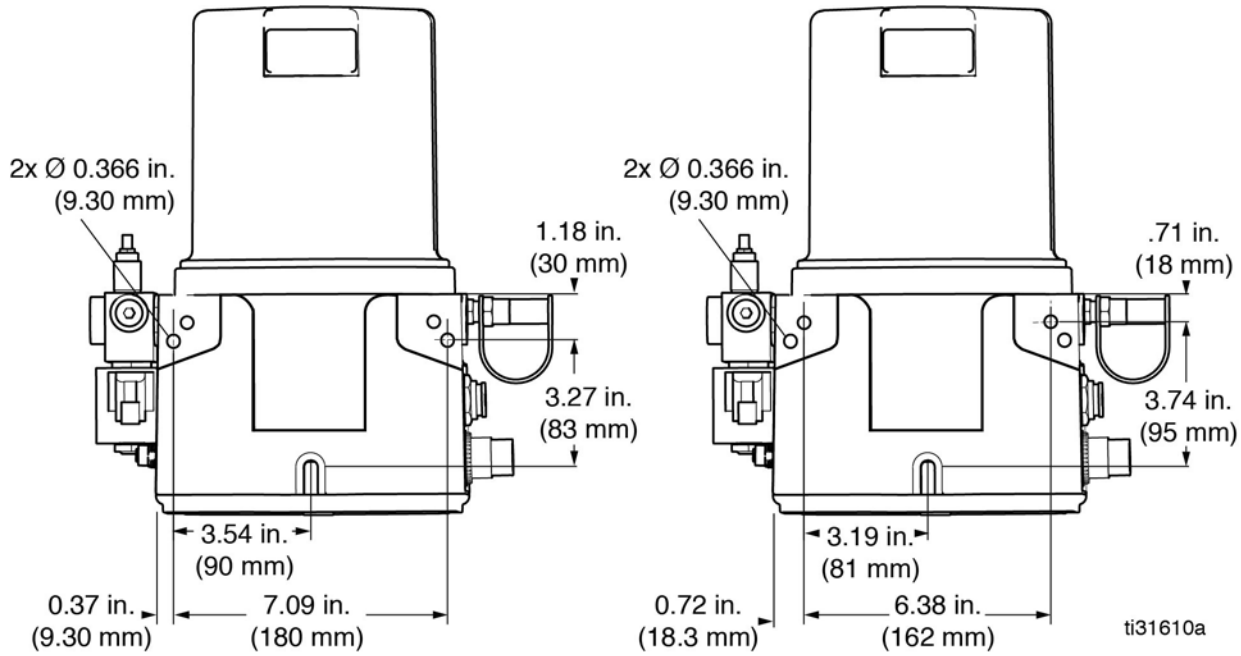
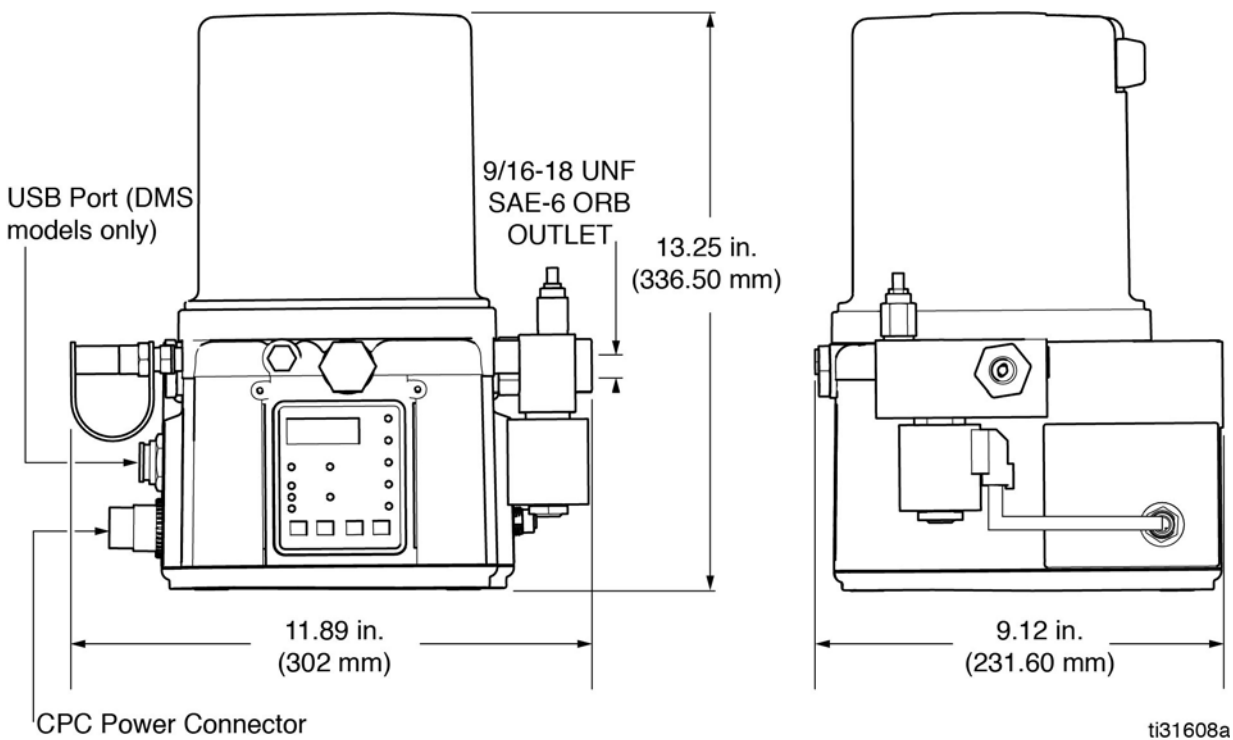

FIG. 7

Choosing an Installation Location

- Select a location that will adequately support the weight of the pump and lubricant, as well as all plumbing and electrical connections.

NOTE:

- The user-supplied mounting hardware must be strong enough to adequately support the weight of the pump and lubricant, as well as all plumbing and electrical connections.
- Mount the pump in a location that provides easy access to the pump controls and fill port.
- Mount the pump in a location that provides protection from common hazards that could damage the pump. Consider all road hazards the pump may be exposed to when choosing a mounting location.
- Do not mount the pump near the Diesel Exhaust Fuel (DEF) exhaust pipe.
- Use a mounting bracket to secure the pump directly to either the outside or inside of the lower truck frame as shown in FIG. 8.

NOTE:

- Mounting bracket, Part No. 17S107, suitable for mounting on most truck frames, is available from Graco. Contact your local Graco distributor for assistance with ordering this part.
- See FIG. 9, page 13 for bracket with pump dimensions.

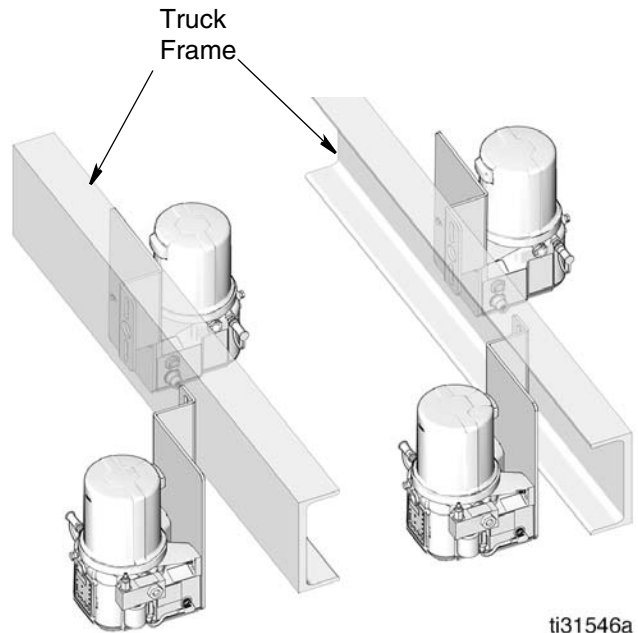

ti31546a

FIG. 8

Mounting Bracket and Pump Dimensions

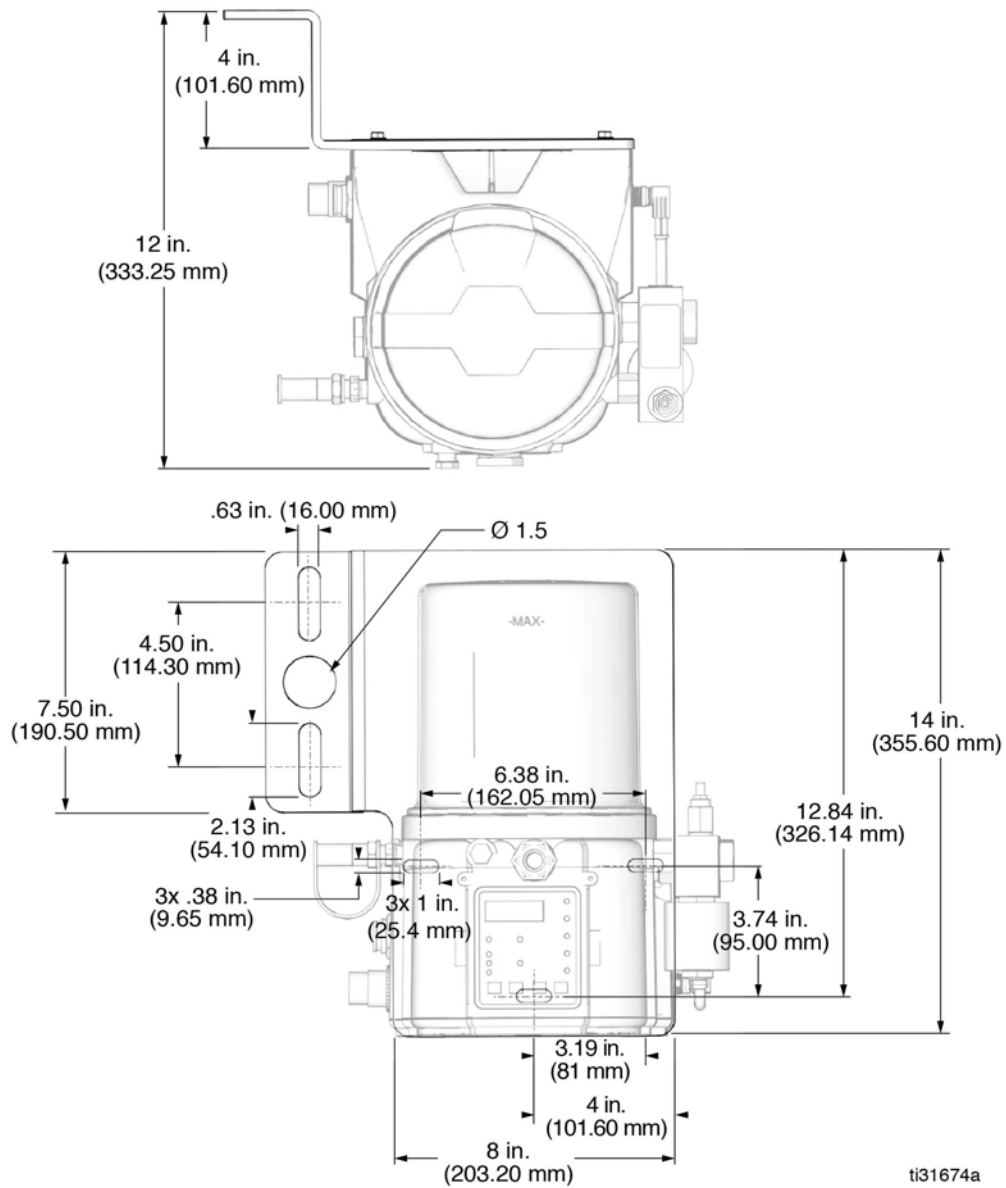
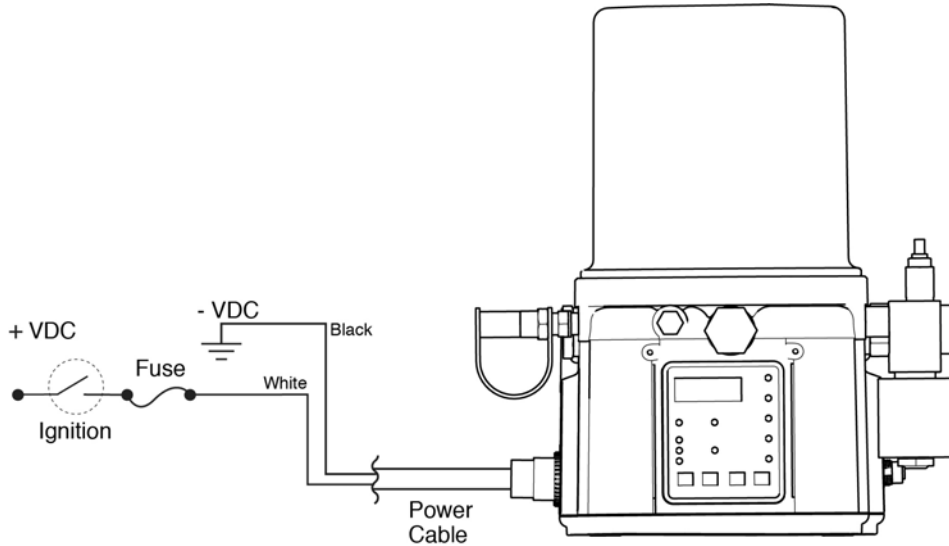

FIG. 9

Pump

Pump Wiring Diagram (Standard Models: 24Z764 and 24Z959)

The pump requires a 2-wire, CPC Connector Cable (Part No. 129644) to power the pump. See the Wiring Schematic provided in FIG. 10.



ti31668a

FIG. 10

Pump Wiring Diagram (Models with DMS and Illuminated Remote Run Button: 24Z660 and 24Z958)

The pump requires a 5-wire, CPC Connector Cable (Part No. 127782) to power the pump and illuminated remote run button. See the Wiring Schematic provided in FIG. 11.

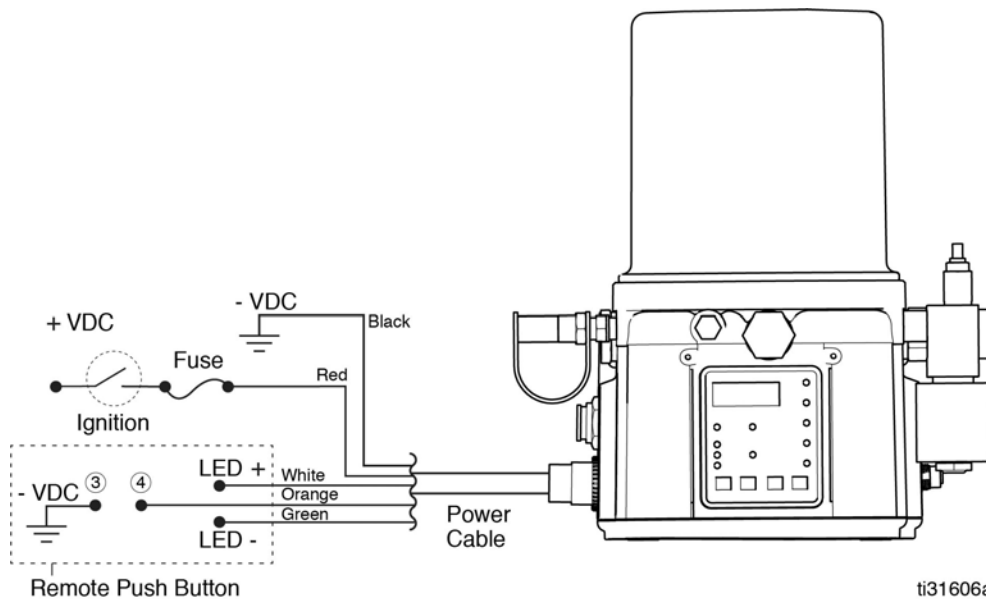

ti31606a

FIG. 11

Low Level Fault/Warning

When approximately one lubrication cycle remains, the blinking, yellow, low level warning light on the pump panel, illuminates and Er:LL appears on the display as shown in FIG. 12. Fill the reservoir as soon as possible.



ti31629a

FIG. 12

If the pump reservoir is not refilled with grease, the pump will stop. A blinking, red, low level fault light and Er:LL appears on the display as shown in FIG. 13.



ti31629a

FIG. 13

Pumps with a remote run button will indicate the low level warning and low level fault as shown on the Low Level Fault/Warning Table.

Low Level Fault/Warning Table

| Warning or Fault | Illumination |
|-------------------|-----------------|
| Low Level Warning | Yellow blinking |
| Low Level Fault | Red blinking |

Fuses

NOTICE

Fuses (user supplied) are required on all pump models. To avoid equipment damage:

- Never operate pump without a fuse installed.
- A fuse of the correct voltage must be installed in line with the power entry to the system.

Graco Fuses

| Part No. | Description | Amps |
|----------|-------------|----------|
| 25C985 | 12 VDC | 10 Amps |
| 25C986 | 24 VDC | 7.5 Amps |

Pump Over-Current Protection

The pump has built-in over-current protection to protect the motor. In cold weather installations, if the grease freezes causing the motor to draw more current; the motor will try to start the pump 90 times before shutting down.

How Over-Current Protection Works

When the pump is unable to start the ON Time cycle, an over-current condition is created:

- The pump immediately goes into the set OFF Time mode.
- At the end of the OFF Time mode the pump again attempts to run the ON Time cycle. One of two results are possible at this point:
 - the pump runs the ON Time cycle as scheduled and normal cycle operation begins.
 - the pump is still not able to start (condition is still in over-current) and the immediately goes into the programmed OFF time again. This will repeat for 90 times before shutting down entirely.

Pump

Illuminated Remote Run Button

Available on Pump Models 24Z660 and 24Z958 only.

Parts:

25C981 - 12VDC
25C982 - 24 VDC

| Ref | Part No. | Description | Qty |
|-----|----------|-----------------------|-----|
| 51 | | Push button | 1 |
| 52 | | Connector | 4 |
| 53 | | Button Label | 1 |
| 54 | | O-ring | 1 |
| 55 | 129336 | Cab Information Label | 1 |

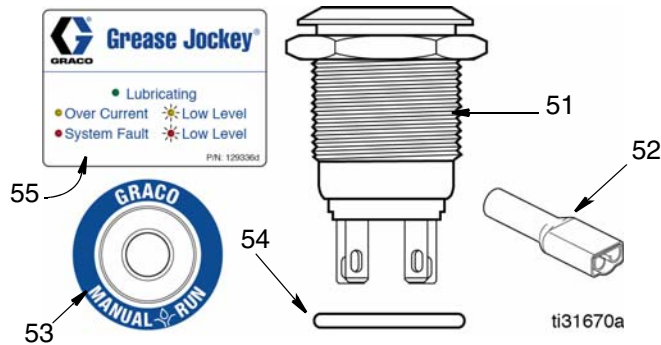

FIG. 14

Installation

Install the remote run button in an easily accessible location inside the truck cab.

1. Drill a hole in the panel. (See the illustration on the right for cutout dimension. The maximum panel thickness is 0.472 in./12.0 mm).
2. Remove the lock nut (51a) from the push button (51). Install the o-ring (54) (FIG. 15).

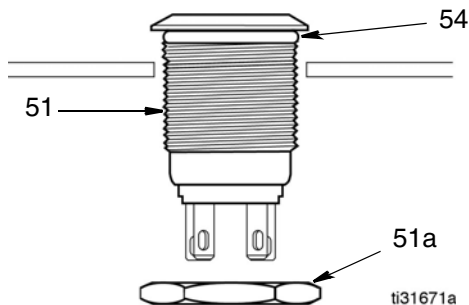
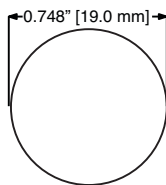

FIG. 15

3. Insert the push button (51) through the hole drilled through the panel in Step 1. Hand tighten the lock nut (1a) to secure the push button in place (FIG. 15).
4. Clean the surface around the outer edge of the push button (1). Position label (53) around the button and adhere label (FIG. 16).

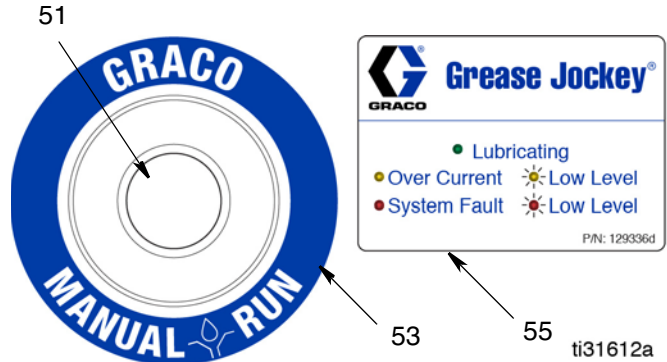

FIG. 16

5. Clean the an area close to the push button for mounting the label (55) inside cab. Adhere label to mounting surface.
6. Connect the wiring connector (52) to the push button and the pump. See Pin and Related Wire Color Table (below) and Wiring information shown in FIG. 17, page 17.

Pin and Related Wire Color (FIG. 17)

| Pin | Pin Name | Color |
|-----|-------------------|----------|
| 1 | Not Used | Not Used |
| 2 | -VDC | Black |
| 3 | +VDC | Red |
| 4 | LED+ | White |
| 5 | Manual Run Switch | Orange |
| 6 | Not Used | Not Used |
| 7 | LED- | Green |

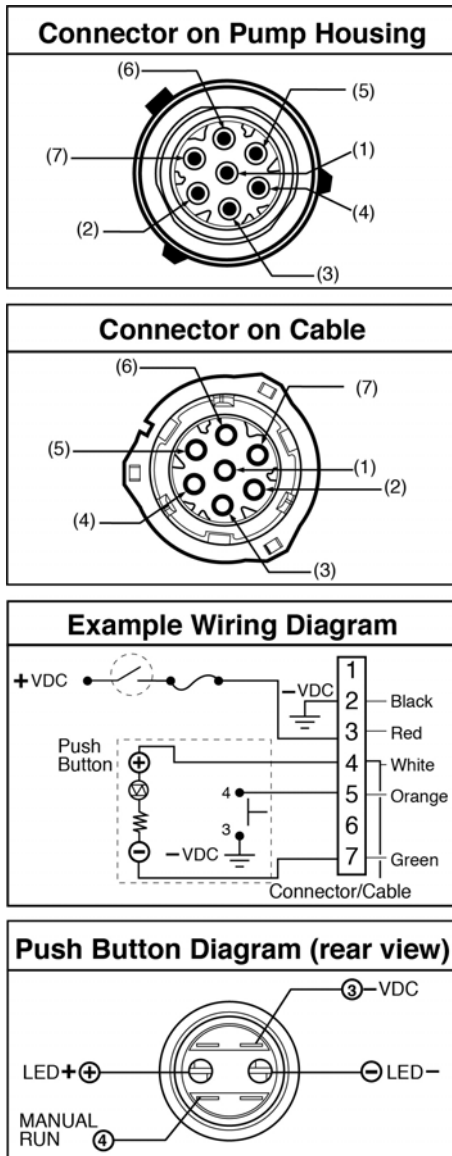

FIG. 17

Tri-Color Remote Illumination

| | Tri-Color Remote Illumination |
|-------------------------------|---|
| Pump in OFF Mode | No indication |
| Pump in ON Mode | Green - ON |
| Low Level Warning | Yellow - Toggles ON and OFF once per second |
| Overcurrent Warning Condition | Yellow |
| Low Level Fault | Red - Toggles ON and OFF once per second |
| System Fault | Red |

Direct Mount Vent Valve

The Direct Mount Vent Valve is installed on the pump when it is shipped to the customer from Graco. Vent Valve Replacement Kit 25C965 for 12 Volt pumps and 25C966 for 24 Volt pumps are available from Graco. Contact your local Graco Distributor or Graco Customer Service for assistance when ordering this part.

Connect one end of the vent valve cable (36) (Graco Part No. 129801) to the vent valve connector on the pump. Connect the other end of the cable to the vent valve (35) as shown FIG. 18.

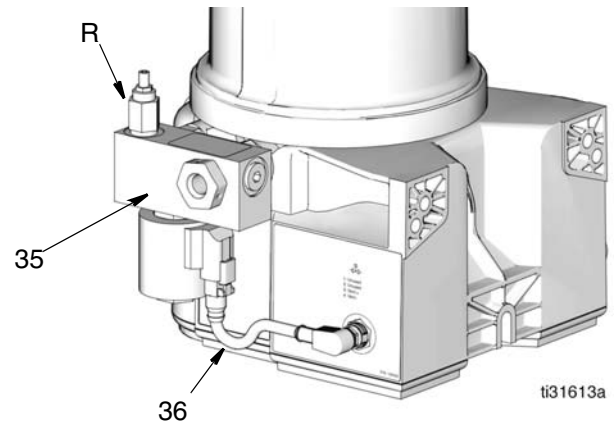

FIG. 18

Vent Valve Outputs

See Technical Data, page 65 for ratings.

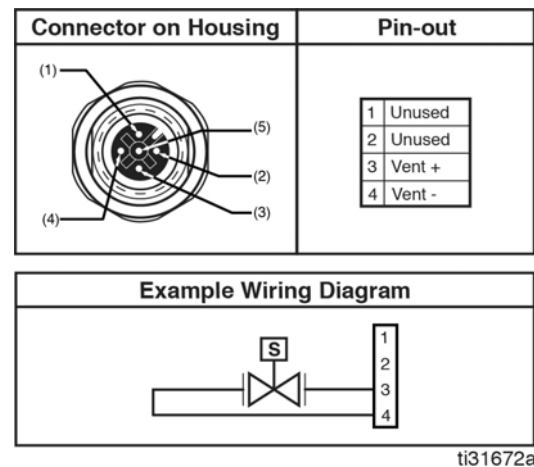



FIG. 19

Pump

Pressure Relief Valve (FIG. 18, R)

The pressure relief valve is preset to 2000 psi (13.79 MPa, 137.9 bar). **DO NOT ADJUST THIS SETTING.**

| | | | | |
|---|---|--|--|--|
|  |  | | | |
| SKIN INJECTION HAZARD Adjusting the pressure relief valve to increase the pressure may result in hose leaks or ruptured components which could result in a serious skin injection injury. | | | | |

Adjusting the pressure relief valve to decrease the pressure may negatively impact the performance of the pump or the lubrication system.

Pump Setup

Filling Reservoir

To ensure optimal performance from the pump:

- Only use NLGI #000 - #2 greases appropriate for your application, automatic dispensing, and the equipment's operating temperature. Consult with machine and lube manufacturer for details.
- The reservoir can be filled using a pneumatic pump or electric transfer pump.
- Do not overfill (FIG. 21).
- Do not operate without reservoir attached.

NOTICE

- Always clean inlet fitting (25) (FIG. 20) with a clean dry cloth prior to filling reservoir. Dirt and/or debris can damage pump and/or lubrication system.
- Care must be used when filling the reservoir using a pneumatic or electric transfer pump to not pressurize and break the reservoir.

1. Remove dust cap (26) and connect fill hose to inlet fitting (25) (FIG. 20).

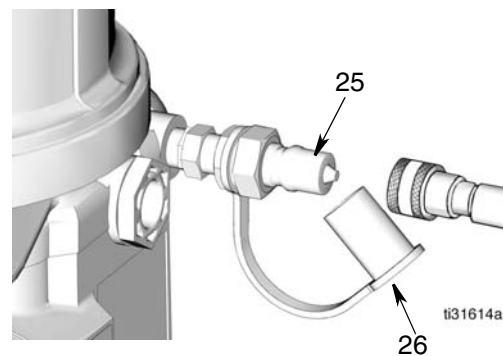

FIG. 20

2. For higher viscosity fluids, start pump to rotate stirring paddle during fill to prevent air pockets from forming in grease.

To start the pump press the manual run button.



3. Fill reservoir to max fill line.

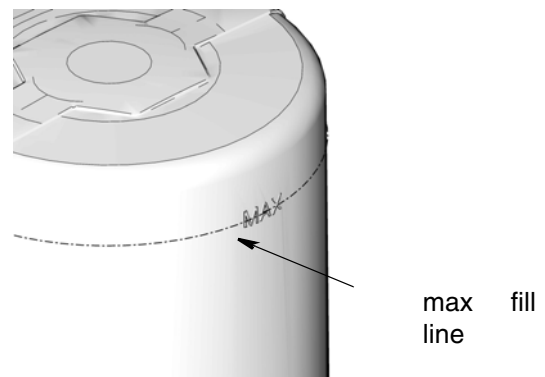

FIG. 21

NOTE: The reservoir air vent (P), located in rear of reservoir, should not be used as an overfill port/indicator.

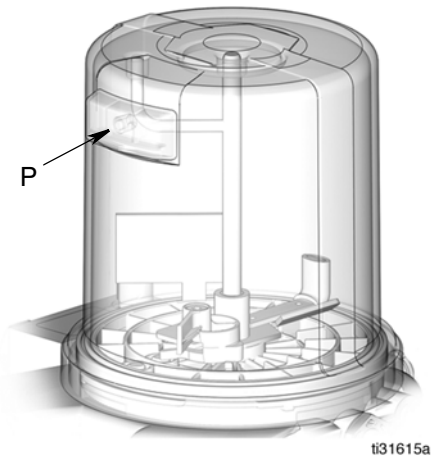

FIG. 22

4. When the grease has reached the max fill line (FIG. 21), remove the fill hose and replace the dust cap (26) over the inlet fitting (25).

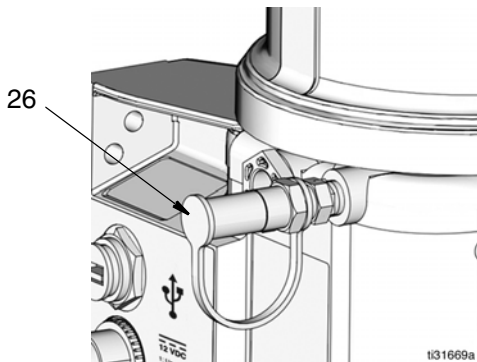

FIG. 23

Priming

NOTE: It is not necessary to prime the pump every time the pump is filled with lubricant.

The pump only requires priming the first time it is used or if it is allowed to run dry.

1. Loosen the pump outlet fitting (FIG. 24).

NOTE: When loosening pump outlet fitting, do NOT loosen banjo bolt (A).

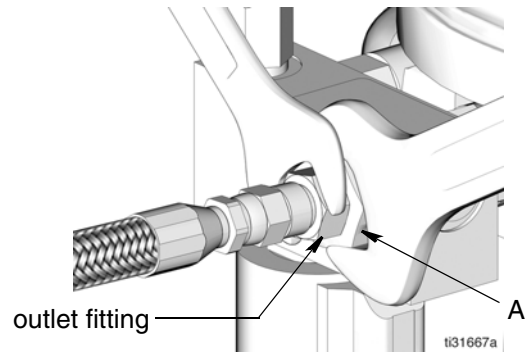

FIG. 24

2. Only run pump until air is no longer dispensed with the lubricant (lu) coming out of outlet fitting (FIG. 25).

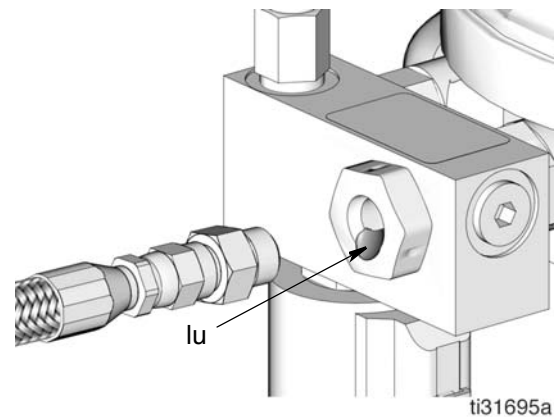

FIG. 25

3. Tighten pump element fitting using two wrenches working in opposite directions.

Programming the Pump

Control Panel Overview (FIG. 26)

NOTE: Programming instructions begin on page 21.

ON TIME

- LED lights when ON Time is running.
- Display shows time as MM:SS (minutes and seconds). i.e., 08:30 is 8 minutes: 30 seconds.
- Counts down from a set time to zero.

DISPLAY

- A blinking LED under HH, MM, SS or ## identifies type of measurement unit you are setting; i.e., HH is hours.
- A blinking number on the display indicates the pump is in SETUP MODE.
- In RUN MODE displayed numbers count up or down. See Time ON and Time OFF.

OFF TIME

- LED lights when OFF Time is used to control Pump OFF function.
- Value is entered in HH:MM.
- Displays in HH:MM (hours and minutes) when > 1 hour.
- Times pump rest between cycles.
- Counts down from set time to zero.

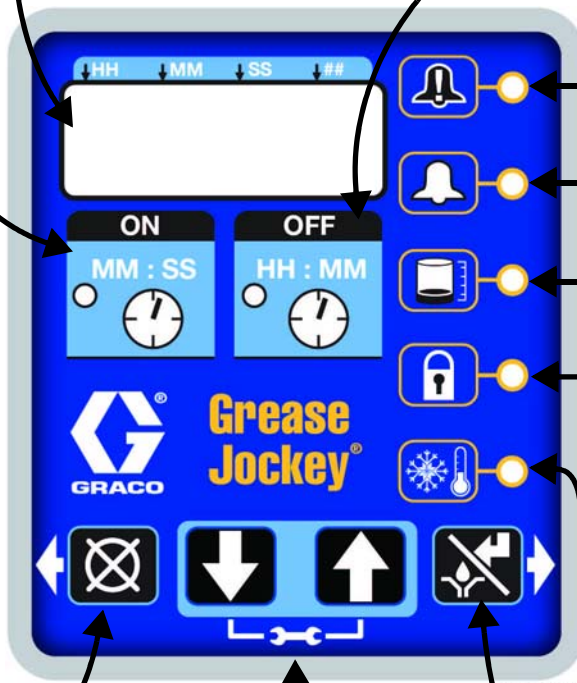

ALARM ICONS

LED next to icon lights when a fault / warning event occurs during a run cycle. See page 36 for a complete description of these alarm scenarios.

PIN ICON

- LED next to icon lights indicating PIN is required to enter setup.
- In SETUP MODE LED lights when setting up the PIN.

COLD DELAY

LED next to icon lights indicating when Cold Delay function is enabled.

LEFT DIRECTION ARROW / RESET

- In SETUP MODES, moves cursor in display one field to the left.
- In RUN MODE: single press clears warning.
- In RUN MODE: Pressing for 1 second ends run cycle if there are no warnings.
- In ALARM MODE: pressing and holding for 3 seconds clears fault / warning and switches cycle to OFF MODE.

UP and DOWN ARROW

- Hold both the UP and DOWN ARROW buttons down together for 3 seconds to enter SETUP MODE.
- In SETUP MODE, increases or decreases number values shown in display.

RIGHT DIRECTION ARROW / MANUAL RUN / ENTER

- In SETUP MODE, saves entry, moves cursor in display one field to the right or to the next setup step.
- In RUN MODE starts a manual run cycle.

FIG. 26

Quick Setup Guide - DMS and Illuminated Remote Run Models

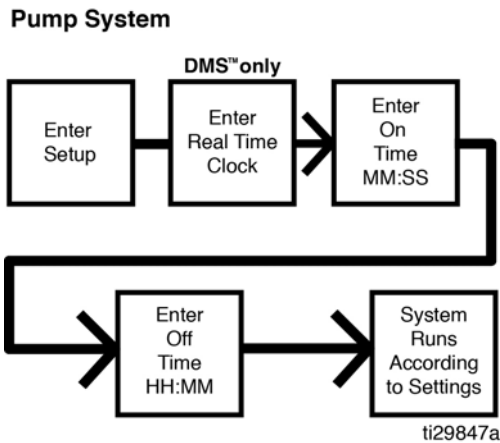

FIG. 27

Pump Software

When the pump is powered, “d7” displays for a short period of time. If it does not display, contact Graco Customer Service.



By default, units with controllers are set to operate in a timed mode with 7 minutes of ON time and 2:53 hours of OFF time. The unit should be powered up in OFF mode, counting down from the 2:53 hours. If the unit powers up in ON mode and has not been primed, hold the reset button located on the control panel (example shown on the right) for 1 second to move to the OFF mode.



NOTE:

- A blinking number on the display indicates the pump is in SETUP MODE.
- In RUN MODE numbers on the display do not blink.
- After 60 seconds of no activity, the device returns to RUN MODE in the OFF Time cycle and the OFF Time restarts counting down the total programmed amount of time. It does **not** resume the countdown from the point where the cycle was interrupted when you entered SETUP MODE.

Entering Setup Mode

Press both the UP and DOWN ARROW buttons together for 3 seconds to enter the SETUP MODE.



NOTE: If the lock LED is lit after entering Setup Mode and four 0000's are displayed, the unit has a PIN Code lock out enabled. See the following section: Entering a PIN Code to Access Setup Mode.

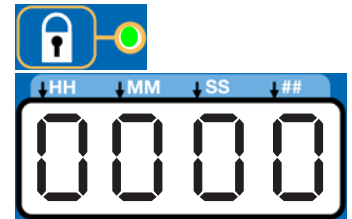

Entering a PIN Code to Access Setup Mode

The controller does not require a user to provide a PIN code to access the programming features of the unit. However, Graco understands that some users may want to protect the programming settings and therefore, an option for adding PIN Code authorization is available. The instructions for setting up PIN Code Authorization are provided in the Advanced Programming section of this manual. See page 32.

To enter the PIN Code:

1. Press both the UP and DOWN ARROW buttons for 3 seconds.



2. The LED next to the LOCK ICON on the display lights and the 4 zeros appear on the display indicating the system requires a PIN Code entry to run the in SETUP MODE.



3. The cursor is automatically positioned to enter the first character of the PIN Code. Use the UP and DOWN ARROW buttons to move up and down through the numbers 0-9 until the first number in the PIN code is displayed in the field.



4. Press the ENTER button to set the number. The cursor automatically moves to the next number field.



5. Repeat steps 3 and 4 for each PIN Code prompt field.

Pump

If the PIN Code you entered is correct, the first editable character on the display will flash.

NOTE: A blinking field on the display indicates the pump is in SETUP MODE. In RUN MODE numbers on the display will not blink.

Setting the Real Time Clock - DMS and Illuminated Remote Run Button Models

NOTE: Set the real time clock prior to plugging the USB flash drive into the pump.

Enter the Year:

- The year displays. The first programmable character, the decade, blinks indicating the device is ready to program the decade digit of the year.
- The LED under the # sign lights while setting the year.

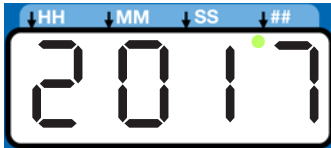

1. Use the UP and DOWN arrow buttons to move up and down through the number 0-9 until the number for the current decade is displayed in the field.
2. Press the ENTER button to set the decade number. The cursor automatically moves to the next field, the year number.
3. Use the UP and DOWN arrow buttons to move up and down through the number 0-9 until the number for the current year is displayed in the field.
4. Press the ENTER button to set the year number.



The 3-character month displays indicating the is now ready to program the month.

Enter the Month:



1. Set the 3 character month by using the UP and DOWN ARROW buttons to move up and down through the list of months until the current month is displayed in the field.
2. Press the ENTER button to set the month.



The 2-digit date displays indicating the is now ready to program the date.

Enter the 2-digit Date:

The first programmable character of the 2-digit date blinks indicating the device is ready to program the first digit of the date.

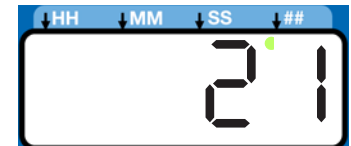

The LED under the # sign lights while setting the date.

1. Use the UP and DOWN ARROW buttons to move up and down through the numbers 0-3 until the first digit of the date is displayed in the field.
2. Press the ENTER button to accept the selection. The cursor automatically moves to the second digit of the date.
3. Use the UP and DOWN ARROW buttons to move up and down through the numbers 0-9 until the second digit of the date is displayed in the field.
4. Press the ENTER button to set the date.





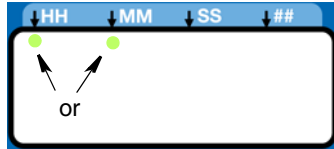

The time displays indicating the is now ready to program the time.

Enter the Time:

- The time displays in 24-Hour format. i.e., 2:45 PM displays as 14:45.
- The clock is set in Hours and Minutes (HH:MM).
- The LED under the HH lights when setting hours and the LED under the MM lights when setting minutes.
- The first programmable number of the HH (hour) field blinks, indicating the device is ready to program the first digit of the hour.
- When programming a time of less than 12 hours, you must program a leading zero in the first number field and press the ENTER button to save the zero.



- Use the UP and DOWN ARROW buttons to move up and down through the numbers 0-2 until the desired number appears in the first hour (HH) field.
 
- Press the ENTER button to set the number.
 
- Use the UP and DOWN ARROW buttons to move up and down through the numbers 0-9 until the desired number for the second HH number field appears.
- Press the ENTER button to set the number.
 
- The next number field to the right blinks and the LED under the MM lights indicating the is ready to program the minutes fields.
- Repeat steps 1-4 to set the minutes (MM) fields.
- After pressing the ENTER button to set the time, the programmed Time information is saved.
 

ON Time

- The LED next to the clock in the ON field lights, indicating you are setting the ON Time parameters.



- ON Time is set in Minutes and Seconds (MM:SS).

- An LED flashes under either MM when programming minutes **OR** SS when programming seconds.

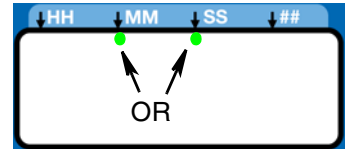

- In SETUP MODE, the number displayed in the first field, on the left side of display blinks, indicating the device is ready to program the ON Time minutes.

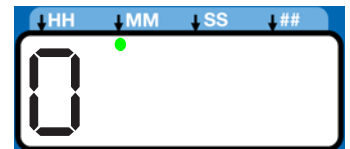

- The total amount of ON Time cannot be 0 or exceed 30 minutes. If a value of 0 or a value greater than 30 minutes is entered, the RED alarm LED lights and the value must be updated.



Pump

Programming ON Time

NOTE: When programming a time of less than 10 minutes you **must** program a leading zero in the first number field and press the ENTER button to save the zero selection.

1. To set the ON Time use the UP or DOWN ARROW button to scroll through numerals 0 to 9 until the desired number appears in the first MM (minutes) field.



2. Press the ENTER button to lock in the selection. The next MM number field to the right flashes indicating it is ready for programming.



3. Use the UP or DOWN ARROW button to scroll through numerals 0 to 9 until the desired number appears in the second MM number field.



4. Press the ENTER button to lock in the selection.



The next number field to the right flashes and the LED lights under SS; indicating it is ready to program the seconds fields.

5. Repeat steps 1 - 4 to set the SS (seconds) fields.
6. After pressing the ENTER button to set the last SS field, all the programmed ON Time information is saved.



The device automatically switches to the OFF Time SETUP MODE.

PUMP OFF / REST Setup

After setting the parameter for ON time, the OFF or pump rest cycle must be set up for a specific set amount of time (similar to Time Mode).

OFF Time

- The LED next to the clock in the OFF field lights, indicating you are setting the OFF Time parameters.
- OFF Time is set in Hours and Minutes (HH: MM).
- An LED flashes under either HH when programming hours **OR** MM when programming minutes.
- In SETUP MODE the number displayed in the first field, on the left side of display blinks, indicating the device is ready to program the OFF Time hours.

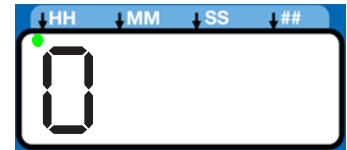
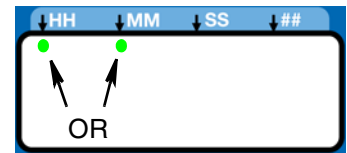

- The total amount of OFF Time must be at least twice as long as the programmed ON Time. If a value less than twice the ON Time is entered, the RED alarm LED lights and the value must be updated. If this time does not meet the application needs, contact Graco Customer Support.



Programming OFF Time

NOTE: When programming a time of **less than 10 hours** you **must** program a leading zero in the first number field and press the ENTER button to save the zero selection.

1. To set the OFF Time use the UP or DOWN ARROW button to scroll through numerals 0 to 9 until the desired number appears in the first HH (hour) field.



2. Press the ENTER button to lock in the selection. The next HH number field to



the right flashes indicating it is ready for programming.

- Use the UP or DOWN ARROW button to scroll through numerals 0 to 9 until the desired number appears in the second HH number field.



- Press the ENTER button to lock in the selection.



The next number field to the right flashes and the LED lights under MM; indicating it is ready to program the minutes fields.

- Repeat steps 1 - 4 to set the next MM (minutes) fields.

- After pressing the ENTER button to set the last MM field, the OFF Time information is saved and the pump automatically switches to the RUN MODE.



DMS™ Models

Downloading Data

- Remove the USB cover from the USB port.
- Plug a USB flash drive into the USB port.

NOTE: The pump stops pumping as soon as the USB flash drive is plugged into it.

- The system automatically begins downloading data to the USB drive.

- “data” is displayed while the system is downloading files.

data

- When download is finished, “done” is displayed.

done

- The pump restarts cycle in the OFF mode.
- Remove the USB flash drive. Replace the USB cover and hand tighten the cover securely over USB port.

Storing Pump Program Settings to the Flash Drive

The pump program settings file is named:

GRACO/Config/config.bin. This file cannot be modified. Modification of the file or file name may cause it to be unusable.

- Plug the USB flash drive into the USB port.

NOTE: The pump stops pumping as soon as the USB flash drive is plugged into it.

- The system automatically begins downloading data to the USB drive.

- “data” is displayed while the system is downloading files.

data

- When download is finished, “done” is displayed.

done

- The pump restarts cycle in the OFF mode.

- After the download is complete, press and hold the UP and DOWN ARROW button for 3 seconds to store the current setup to the USB flash drive.



- “data” is displayed while the unit is downloading and storing the configuration on the USB drive.

data

- When configuration is stored, “done” is displayed.

done

- The pump restarts cycle in the OFF mode.

- Remove the USB flash drive.

Uploading Pump Program Settings to the Pump

- Plug the USB flash drive into the USB port.

NOTE:

- The USB flash drive must contain file GRACO/Config/config.bin.
- The pump stops pumping as soon as the USB flash drive is plugged into it.

Pump

2. The system automatically begins downloading data to the USB drive.

3. "data" is displayed while the system is downloading files.

data

4. When download is finished, "done" is displayed.

done

5. The pump restarts cycle in the OFF mode.

6. After the download is complete, press and hold the RESET button and UP ARROW button for 3 seconds to upload the setup stored in the USB flash drive.



7. "data" is displayed while the unit is uploading the configuration data.

data

8. When upload is finished, "done" is displayed.

done

9. The pump resumes.

10. Remove the USB flash drive.

11. After the USB flash drive is removed, press and hold the UP and DOWN ARROW buttons for 3 seconds to enter the SETUP MODE (see Entering Setup Mode, page 21).



12. In SETUP MODE, set the YEAR, MONTH, DATE and TIME (see Setting the Real Time Clock, page 22).

13. After pressing the ENTER button to set the TIME, press the RESET button to exit the SETUP MODE.



Viewing the UNIT DMS ID Number

1. In RUN mode, press and hold the DOWN ARROW button.



2. The Unit DMS ID number displays. The unit continues to normal operation while the DMS ID is displayed.

3. Release the DOWN ARROW button after viewing the DMS ID number.

Operation / Data Log

During operation the pump stores information as Log and Summary Files.

Logs contain the following information:

- Log Name
- DMS ID Number
- Current Software Graco Part No.
- Current Software Version
- Date and Time of Upload

System Event Log

The System Event Log lists the date and time of the last 800 common system events such as pump cycles, manual run and setting changes. The most recent event is listed first.

The log file is stored in a folder structure created by the pump DMS ID and download date. If multiple downloads are done on the same date, the existing files will be written over.

The folder structure is as follows:

GRACO/{DMS_id}/{download date - YYYYm-mDD}/EVENTLOG.CSV

Example: GRACO/00613/20160911/EVENTLOG.CSV.

Sample System Event Log

Example Event Log: The pump cycle of a typical lubrication system is shown below.

System Event Log

DMS ID Number: 00613

Software Part No.: 17J936

Software Version: 0703

09/29/2016 14:1400

| Date | Time | Description |
|-----------|----------|----------------------------|
| 9/29/2016 | 14:13:02 | Pump Run Off |
| 9/29/2016 | 14:13:02 | Program Variable Change |
| 9/29/2016 | 14:12:39 | Pump Run On |
| 9/29/2016 | 14:12:34 | Local Manual Run Initiated |

Common System Events are listed below.

| | |
|-----------------------------|---|
| Pump Run On | The pump entered an on cycle and is operating and dispensing material. |
| Pump Run Off | The pump entered an off cycle and is not dispensing. |
| Pump Run Canceled | A pump on cycle was canceled by pressing the cancel button on the front panel and holding it for 3 seconds. |
| Program Variable Change | The setup mode was entered. |
| Local Manual Run Initiated | The manual run button was pressed, initiating a pump on cycle. |
| Remote Manual Run Initiated | The remote manual run button was pressed initiating a pump on cycle. |
| Successful Pin Code Entry | The pin code was successfully entered and the user has entered setup mode. |
| Cold Delay | The pump entered a cold delay |
| Firmware Update Completed | The firmware was updated successfully. |

Pump

Error Log

The Error Log lists Set Time and Clear Time for the last 400 faults and warnings. The most recent event is listed first.

The log file is stored as:

GRACO/{DMS_id}/{download date - YYYYm-mDD}/ERRORLOG.CSV

Example: GRACO/00613/20160911/ERRORLOG.CSV.

Sample Error Log

Error Log
 DMS ID Number: 00613
 Software Part No.:17J936
 Software Version:0703
 12/31/2016 23:04:00

| Date | Time | Description |
|------------|----------|------------------------|
| 12/31/2015 | 23:03:54 | Low Level Cleared |
| 12/31/2015 | 23:03:42 | Low Level Fault |
| 12/31/2015 | 23:03:32 | Low Level Warning |
| 12/31/2015 | 23:03:22 | Over Current |
| 12/31/2015 | 23:03:19 | Over Current Shut Down |

Common Error Log entries are listed below.

| | |
|---------------------------|--|
| Software Fault | An internal software error occurred. Contact Graco Customer Service. |
| Low Level Warning | The unit entered a low level warning mode and is running low on material. The pump continues to dispense material for the duration of the low level alarm time specified by the unit. |
| Low Level Fault | The alarm time in low level warning has elapsed. The unit will not pump until the reservoir is filled and the fault is cleared. |
| Motor Overcurrent Warning | The unit is out of expected motor current range. Check the system to determine that it is functioning correctly (i.e., no blocked lines). Continued operation at excessive motor currents will cause degradation in pump life. |

| | |
|---------------------------|--|
| High Temperature Warning | Internal temperature of the unit is above the designated operating temperature. Check the unit and system to determine that it is functioning correctly. Operating outside of the specified temperature range may cause reduced performance and possible unit failure. |
| Motor Overcurrent Fault | The unit is out of expected motor current range. Check the system to determine that it is functioning correctly (i.e., no blocked lines). Continued operation at excessive motor currents will cause degradation in pump life. |
| Low Temperature Warning | Internal temperature of the unit is below the designated operating temperature. Check the unit and system to determine that it is functioning correctly. Operating outside of the specified temperature may cause reduced performance and possible unit failure. |
| Low Power Fault Pump On | The power source does not have enough power to power the pump when it turns on. Replace power source. |
| Low Power Warning Cleared | The voltage of the power source dropped below and acceptable threshold. The warning was cleared either by user intervention, or by self-correction. |
| Low Power Fault Cleared | The voltage of the power source dropped below an acceptable threshold for longer than 15 minutes and the pump faulted out. The fault was cleared by the user. |
| USB Unable to Mount | The USB flash drive that was installed was unable to connect and communicate with the pump. |
| USB Unsupported Device | The USB flash drive is unsupported. Use a different flash drive. |

| | |
|-----------------------|---|
| USB File Not Found | The pump program setting file was not found or created correctly. Restore the setting file to the flash drive. |
| USB Folder Navigation | The pump program setting file was not found or created correctly. Restore the setting file to the flash drive. |
| USB Invalid File | The pump program settings file was not found or created correctly. Restore the setting file to the flash drive. |
| Failed Pin Code Entry | A failed attempt was made to enter the pin code password. |

Functional Summary

The Functional Summary contains two types of data.

- The first report type, labeled **User** (under the Type heading in the first column of the Sample Functional Summary), only provides data compiled since the last time the Functional Summary was reset through present day (see A6 - Clearing the Functional and Technical User Summary, page 33).

This is very similar to the resettable trip odometer in your car.

- The second report type, labeled **Factory** (under the Type heading in the first column of the Sample Functional Summary), covers the cumulative life of the pump from the first day it was put into service through present day.

This is very similar to an odometer in your car.

The log file is stored as:

GRACO/pump_{DMS_id}/{download date - YYYYm-mDD}/FUNCSUM.CSV

Example: GRACO/pump_00025/20100911/FUNCSUM.CSV

Sample Functional Summary

| Functional Summary | | | | | | | | | | | | | | |
|---|------------|-------------|----------|------------|------------------|-------------------|------------------|--------------------|----------------|------------------|--------------|-------------|-------------------|----------------|
| DMS ID Number:00613 (Hold Down Arrow On Pump to View) | | | | | | | | | | | | | | |
| Software Part No.:17J936 | | | | | | | | | | | | | | |
| Software Version:0703 | | | | | | | | | | | | | | |
| 9/13/2016 11:15:35 | | | | | | | | | | | | | | |
| Type | Start Date | Lube Cycles | Pump Run | Powered On | Local Manual Run | Remote Manual Run | Average Run Time | Average Duty Cycle | Max Duty Cycle | Low Level Faults | Other Faults | Fault Hours | Low Level Warning | Other Warnings |
| User | 9/13/2016 | 29 | 0 hrs | 119 hrs | 25 | 2 | 0:01:30 | 0.62% | 0.62% | 4 | 1 | 112 hrs | 11 | 0 |
| Factory | 9/13/2016 | 29 | 0 hrs | 119 hrs | 25 | 2 | 0:01:30 | 0.62% | 0.62% | 4 | 1 | 112 hrs | 11 | 0 |

Common Functional Summary Data entries are listed below.

| | |
|--------------------------|---|
| Number of Cycles | The number of lubrication cycles the unit has started. |
| Total Run Hours | Total amount of hours the pump has been in the ON mode of the ON/OFF cycle. |
| Total Powered On Hours | Total number of hours that the unit has been powered on. |
| Local Manual Run | The number of times the manual run button was pressed. |
| Remote Manual Run | The number of times the remote manual run button was pressed. |
| Average Run Time | The average amount of time per lubrication cycle that the pump has been running (MM:SS). |
| Average Duty Cycle | The average percentage of time the unit has been pumping while it has been powered on. |
| Max Duty Cycle | The highest percentage of time for one lubrication cycle that the unit has been pumping while it has been powered on. |
| Total Low Level Faults | Total number of low level faults. |
| Total Other Faults | Faults other than low level or sensor feedback. |
| Total Fault Hours | Number of hours the system has been powered on in fault mode. |
| Total Low Level Warnings | Number of low level warning conditions. |
| Total Other Warnings | All other warnings, including temperature and motor current. |

Technical Summary

The Technical Summary contains two types of data.

- The first report only provides data compiled since the Pump Summary was reset to present day (see A6 - Clearing the Functional and Technical User Summary).

This is very similar to the resettable trip odometer in your car.

- The second is a report that covers the cumulative life of the pump from the first day it was put into service to present day.

This is very similar to an odometer in your car.

The log file is stored as:

GRACO/{DMS_id}/{download date - YYYYm-mDD}/TECHSUM.CSV

Example: GRACO/00025/20100911/TECHSUM.CSV

Common Technical Summary Data entries are listed below.

| | |
|----------------------------------|---|
| Average Input Board Voltage (DC) | The average input voltage measured by the internal circuit board. |
| Peak Input Board Voltage (DC) | The peak input voltage measured by the internal circuit board. |
| Average Motor Current | The average motor current measured by the unit. |
| Peak Motor Current | The peak motor current measured by the unit. |
| Average Internal Temperature | The average internal temperature seen by the unit. |
| Peak Internal Temperature | The peak internal temperature seen by the unit. |
| Low Internal Temperature | The lowest internal temperature seen by the unit. |

Pump

Sample Technical Summary

| | | | | | | | | |
|---|------------|-----------------------|--------------------|-----------------------|--------------------|-----------------------|--------------------|-------------------|
| Functional Summary | | | | | | | | |
| DMS ID Number:00613 (Hold Down Arrow On Pump to View) | | | | | | | | |
| Software Part No.: 17J936 | | | | | | | | |
| Software Version:0703 | | | | | | | | |
| 9/13/2016 11:15:35 | | | | | | | | |
| | | | | | | | | |
| Latest Values | | | | | | | | |
| Temp | Voltage | | | | | | | |
| 25C | 11.846 | | | | | | | |
| | | | | | | | | |
| Type | Start Date | Average Board Voltage | Peak Board Voltage | Average Motor Current | Peak Motor Current | Average Internal Temp | Peak Internal Temp | Low Internal Temp |
| User | 9/13/2016 | 11.842 | 11.908 | 2.426 | 2.945 | 29C | 31C | 21C |
| Factory | 9/13/2016 | 11.842 | 11.908 | 2.426 | 2.945 | 29C | 31C | 21C |

Advanced Programming

There are 3 Advanced Programming options. The following Table Identifies each option and when it is used.

| Advanced Option | Model | Setting | Format/ Description | Why Use This? |
|-----------------|---|---|---|---|
| A1 | All Models | Lockout Code (Optional) | Secures setup modes with PIN | Prevents unauthorized users to adjusting settings. |
| A6 | DMS Models | Functional and Technical User Summary Reset | Clears the Functional and Technical User Summaries | Allows user to track lube events from a specific point (reset), i.e. a month to month evaluation. |
| A10 | Basic Models with Firmware 6.03 and later. DMS models with Firmware 7.07 and later | Low Level Reset Upon Power On | Clears low level fault upon power on. Pump will turn on for 5 revolutions to check if low level is still present. | Allows self-clearing of low level fault. |

Entering a PIN Code for the First Time

A1 - Setting Up PIN Code

A PIN Code can be programmed into the pump to protect the settings from inadvertently being changed by unauthorized users.

1. Press the UP ARROW button for 10 seconds.



The LED next to the LOCK ICON on the display lights, indicating you have entered the PIN Mode.





2. The word OFF appears in the display. Press the UP or DOWN ARROW button to change this to ON.



3. Press the ENTER button to enter the PIN Code.





- The cursor automatically is positioned to entered the first character of the PIN Code. Use the UP and DOWN ARROW buttons to move up and down through the numbers 0-9 until the first number in the PIN code is displayed in the field. 
- Press the ENTER button to set the number. The cursor automatically moves to the next number field. 
- Repeat steps 4 and 5 for each PIN Code prompt field.
- Press the ENTER button to save the PIN Code and exit Advanced Setup. 

Entering Advanced Setup

Press the UP ARROW button for 10 seconds.







If the pump was previously set up to require a PIN Code, the LED next to the LOCK ICON lights, indicating a PIN Code is required.

- The cursor is automatically positioned to enter the first character of the PIN Code. Use the UP and DOWN ARROW buttons to move up and down through the numbers 0-9 until the first number in the PIN code is displayed in the field. 
- Press the ENTER button to set the number. The cursor automatically moves to the next number field. 
- Repeat steps 1 and 2 for each PIN Code prompt field.





If the PIN Code you entered is correct, the first editable character on the display will flash.



Selecting Advanced Setup Options

- Press the UP or DOWN ARROW button to move up or down between Advanced Options. 
- Press the ENTER button to set the selection. 
- When the correct number displays, press the ENTER button to set the number. 
- Repeat 2 - 3 to set the remaining fields.
- Press the ENTER button to exit Advanced Programming. 

A6 - Clearing the Functional and Technical User Summary (DMS™ Models only)

The Pump Summary shows run details since the last time the summary was cleared.

- Press the UP or DOWN ARROW button to move through Advanced Options until Advanced Option A6 is displayed. 
- Press the ENTER button. 
- "Data" displays. 
- Press the RESET button. "Reset" displays. The summary data is cleared. 

- Press the RESET or ENTER button to exit.  

Pump

A10 - Low Level Reset Upon Power On. (Models with Firmware 5.04 and later. DMS Models with Firmware 7.07 and later.)

This function changes the behavior of the low level upon pump power on. When A10 is on, a low level fault clears when the pump power is cycled. The pump will revolve 5 revolutions, checking to see if the low level condition is still present. If not, it will self clear and continue. If a low level condition exists during the 5 revolutions, it will go into a low level fault.

Low Level ON LED illuminates (FIG. 28).



FIG. 28

Time Control

After setup is complete, the pump automatically begins to run the OFF Time sequence (FIG. 29).

- The pump runs the programmed OFF sequence.

(Notice the OFF Time LED on the display lights and the OFF Time counts down on the display.)

- The example shown in FIG. 29 shows an OFF Time of 1 hour and 32 minutes before the lubrication cycle begins.



FIG. 29

- The default OFF is displayed. The alarm output will toggle once a second.

OFF

- Press the UP or DOWN ARROW button to move through Advanced Options until Advanced Option A6 is displayed.



- Press the ENTER button.



- When the OFF Time count reaches zero, the pump turns the pump on and it runs for the programmed ON Time cycle (FIG. 30).

(Notice the ON Time LED is now illuminated on the display.)

- The example shown in FIG. 30 shows an ON Time of 6 minutes before the lubrication cycle ends.



FIG. 30

- When the ON Time count reaches zero, the pump shuts off again and the system again runs OFF Time cycle and the OFF Time LED is now again illuminated (FIG. 29).

This sequence repeats itself until the device is reprogrammed or an alarm occurs.

- If power to the pump is lost during a lubrication cycle, when power is restored the pump will resume the cycle with the same amount of time remaining in the cycle as when the power was lost.

Cold Delay

In DMS models, when the pump powers on when the temperature is below 14°F (-10°C), there is a 15 minute cold delay before the pump resumes running the program.

- When power to the unit cycles OFF then ON.
- Temperature is below 14°F (-10°C).
- Unit immediately begins the Cold Delay count down and then the pump resumes.
- The LED next to the clock in the OFF field is illuminated (FIG. 31).
- The Cold Delay LED lights (FIG. 31).
- The display shows time remaining until the pump resumes. The example shown in FIG. 31 shows 8 minutes and 14 seconds left until the pump resumes.



FIG. 31

Manual Run Cycle



To run an extra (non-programmed) lubrication cycle, push the Manual Start button.

Pump

Alarms



Any time a Fault / Warning occurs, a combination of LED's will illuminate to notify you there is a problem and help identify the kind of Fault / Warning has occurred.



- Faults and Warnings will not automatically clear.
- To clear an fault, press and hold the RESET button on the display button pad for 3 seconds.
- To clear a warning press and immediately release the RESET button.



Fault / Warning Scenarios

The following pages describe the most likely fault / warnings you could receive.

| Alarm Type | What it Looks Like | What it Indicates | Solution |
|--------------------------|---|---|--|
| Low Level Warning |  <p style="text-align: right; font-size: small;">ti31629a</p> | <p>Level of lubricant in reservoir is low and additional lubricant needs to be added.</p> <p>Unit continues to operate as normal for a limited period of time until a low level alarm is triggered.</p> | <p>Add lubricant to reservoir.</p> <p>After lubricant is added, press the RESET button to clear the warning.</p>  |

| | | | |
|-------------------------------|---|--|--|
| <p>Low Level Fault</p> |  <p style="text-align: right; font-size: small;">ti31629a</p> | <p>Level of lubricant in reservoir is low and additional lubricant needs to be added.</p> <p>Unit stops pumping and displays amount of accumulated time since the alarm was triggered.</p> | <p>Add lubricant to reservoir.</p> <p>After lubricant is added press and hold the RESET button to clear fault.</p>  |
| <p>System Fault</p> |  <p style="text-align: right; font-size: small;">ti31629a</p> | <p>An internal fault has occurred.</p> | <p>Contact Graco Customer Service.</p> |

Pump

Motor Current Warning



The measured motor current is above the recommended operating maximum value. Continued use at excessive motor currents could reduce life or cause permanent damage.

Pump tries running cycle 90 times before shutting down. See Pump Over-current Protection, page 15.

Examine system to make sure it is operating correctly. A blocked line could create excessive motor current

Examine pump to ensure that it is rotating properly.

If necessary, contact Graco Customer Service.

Motor Current Fault



The measured motor current was above the recommended operating maximum value 90 times. Continued use at excessive motor currents could reduce life or cause permanent damage.

Examine system to make sure it is operating correctly. A blocked line could create excessive motor current

Examine pump to ensure that it is rotating properly.

If necessary, contact Graco Customer Service.

Temperature Warning



ti31629a

The internal temperature of the unit is out of its recommended operating range.

Use of the unit outside of the recommended temperature range could cause degraded system performance and possible damage.

Ensure the unit is used in the correct operating environment for the specific temperature: -13° F to 158° F (-25° C to 70° C).

If necessary contact Graco Customer Service.

USB Error

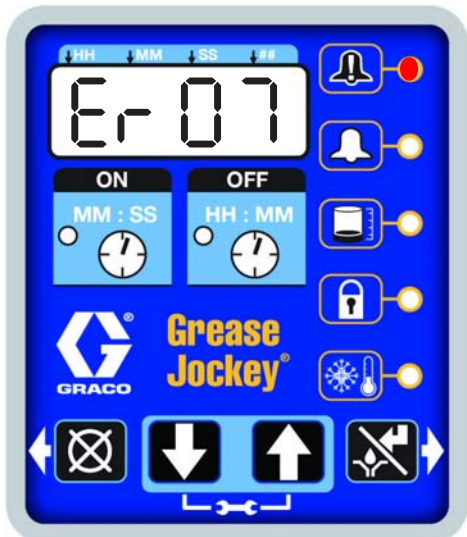



ti31629a

An error occurred during a DMS operation.

Read the Troubleshooting section of this manual (page 61) for error numbers and fault descriptions.

Pump

Fault/Warning Scenarios for Firmware Versions 5.06 and Later for Non-DMS Models and 7.09 and later for DMS Models

| Alarm Type | What it Looks Like | What it Indicates | Solution |
|-------------------|---|--|---|
| Low Power Warning |  <p>The control panel displays 'Er:Po' on the LCD. The top row shows 'HH', 'MM', 'SS', and '#'. Below the LCD are 'ON' and 'OFF' buttons with 'MM:SS' and 'HH:MM' displays. The 'Grease Jockey' logo is prominent. The bottom row contains a 'RESET' button (a square with a circle and an 'X'), a 'DOWN' arrow, an 'UP' arrow, and a 'STOP' button. The 'RESET' button is highlighted with a yellow glow.</p> <p>ti31629a</p> | <p>If there is a voltage drop at the power source during operation, the pump will go into a low power warning condition.</p> <p>The unit will continue to operate for a total of 15 minutes before going into a Low Power Fault.</p> <p>Also if the pump power cycles on power up for a minimum of 3 times, the pump will display a low power warning.</p> <p>If the warning condition clears itself, the warning is cleared and the unit continues operation.</p> | <p>Check voltage and available current output at the power source of the pump.</p> |
| Low Power Fault |  <p>The control panel displays 'Er:Po' on the LCD. The top row shows 'HH', 'MM', 'SS', and '#'. Below the LCD are 'ON' and 'OFF' buttons with 'MM:SS' and 'HH:MM' displays. The 'Grease Jockey' logo is prominent. The bottom row contains a 'RESET' button (a square with a circle and an 'X'), a 'DOWN' arrow, an 'UP' arrow, and a 'STOP' button. The 'RESET' button is highlighted with a red glow.</p> <p>ti31629a</p> | <p>There is a low voltage condition at the power source.</p> | <p>Check voltage and available current output at the power source of the pump.</p> <p>Press and hold the RESET button to clear fault.</p>  |

Testing Installation

NOTE: Complete instructions for programming the Electric Grease Jockey pump begin on page 59.

1. Power up pump and enter Setup Mode by pressing both the UP and DOWN ARROW buttons together for 3 seconds.



2. Button will flash green.
3. Press Reset button exit test.



Manual Run Cycle

To run additional Run Time, push the button.

Manifold

Manifold

There are two manifold sizes.

- 6 port manifold - used in lubrication systems with 6 or less lubrication points (FIG. 32 and FIG. 34).
- 12 port manifold - used in lubrication systems with 7 to 12 lubrication points (FIG. 33 and FIG. 34).

Parts: 6 port models

| Ref | Part No | Description | Qty |
|-----|---------|--|-----|
| 101 | | INJECTOR (see Injector Parts, page 42) | |
| 119 | | MANIFOLD, 6 port | 1 |
| 121 | | STEM, manifold | 1 |
| 122 | 25C988 | NUT | 1 |
| 123 | | WASHER | 1 |
| 124 | | O-RING | 1 |
| 126 | 24Z808 | PLUG with O-Ring, manifold | |

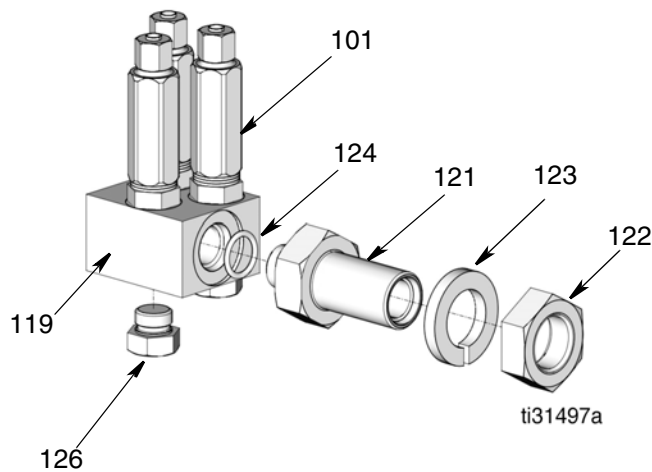

FIG. 32

Parts: 12 port models

| Ref | Part No | Description | Qty |
|-----|---------|--|-----|
| 101 | | INJECTOR (see Injector Parts, page 42) | |
| 120 | | MANIFOLD, 12 port | 1 |
| 121 | | STEM, manifold | 1 |
| 122 | 25C989 | NUT | 1 |
| 123 | | WASHER | 1 |
| 124 | | O-RING | 1 |
| 125 | 129752 | PLUG, cap, hex head | 2 |
| 126 | 24Z808 | PLUG with O-Ring, manifold | |

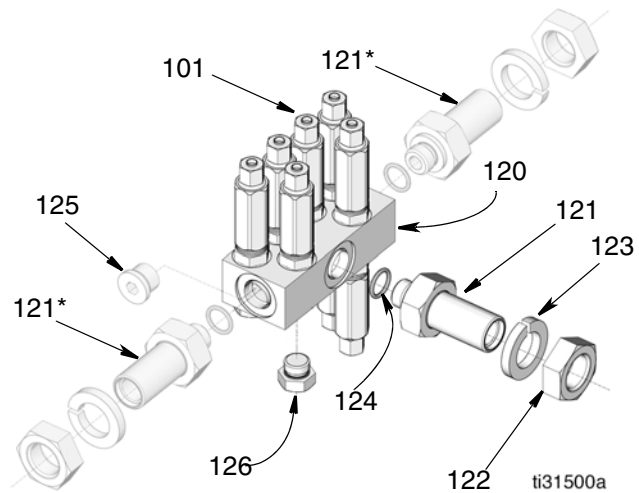

FIG. 33

*In FIG. 33 the Manifold Stem (121) is shown installed in the bottom port. It can also be installed in the side ports.

Manifold Dimensions

6 Point Manifold Dimensions

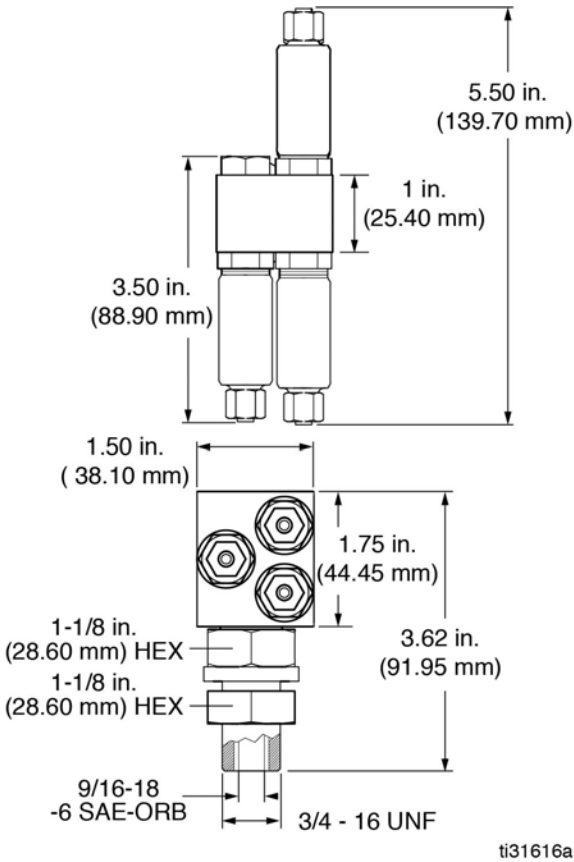

FIG. 34

12 Point Manifold Dimensions

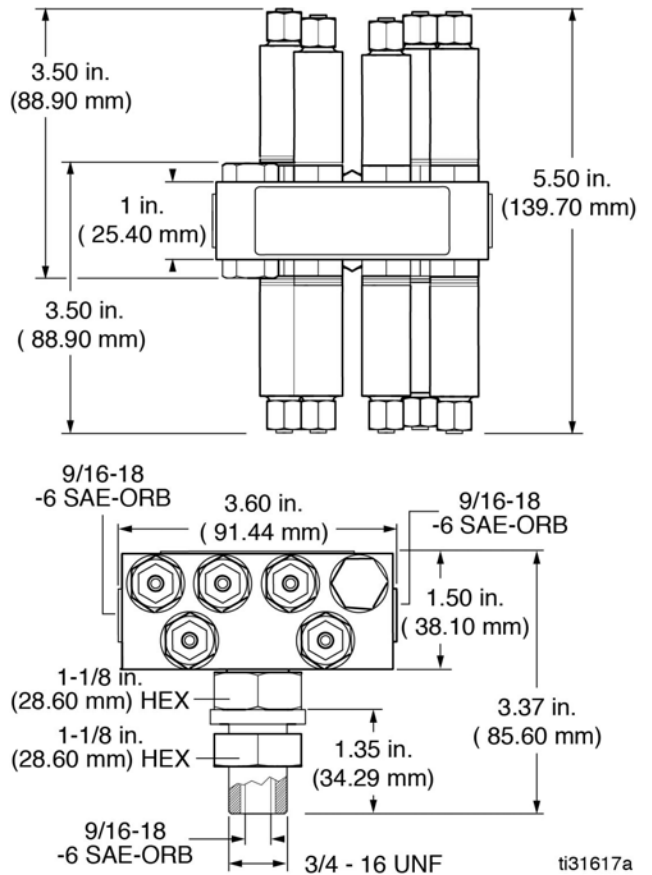

FIG. 35

Injector Manifold Assembly

Injector outputs can be combined for a common bearing point with a large grease requirement but the output for a single injector cannot be split into multiple bearing points.

1. Install the manifold stem (121) and o-ring (124) in the inlet port of the injector manifold (119 or 120) (FIG. 32 and FIG. 33, page 42).

NOTE: The inlet port on the 12 point manifold (120) can be installed in the side or top inlet port.

2. Use plugs (126), to block any ports not used in the injector manifold (FIG. 32 and FIG. 33, page 42). Be sure o-ring is installed on the plug. If additional lube points are needed these plugs can be removed and replaced with appropriate sized injectors and lube lines.

Injectors Parts

| Ref | Part No | Description | Qty |
|-----|---------|--|-----|
| 101 | | SEAL, gasket | 1 |
| 102 | | BODY, injector | 1 |
| 103 | | CUP, retaining | 1 |
| 104 | 556586 | O-RING, 5-058 | 1 |
| 105 | 556660 | NUT, sleeve assembly, 3/16 tube | 1 |
| 110 | 557898 | SPACER, output, model 24Z682; injector size #0 | 0 |
| | | SPACER, output, model 24Z683; injector size #1 | 1 |
| | | SPACER, output, model 24Z684; injector size #2 | 2 |
| | | SPACER, output, model 24Z685; injector size #3 | 3 |
| | | SPACER, output, model 24Z686; injector size #4 | 4 |
| | | SPACER, output, model 24Z681; injector size #8 | 4 |
| 112 | | SPRING, compression | 1 |
| 114 | | BODY, valve | 1 |
| 117 | | O-RING | 1 |

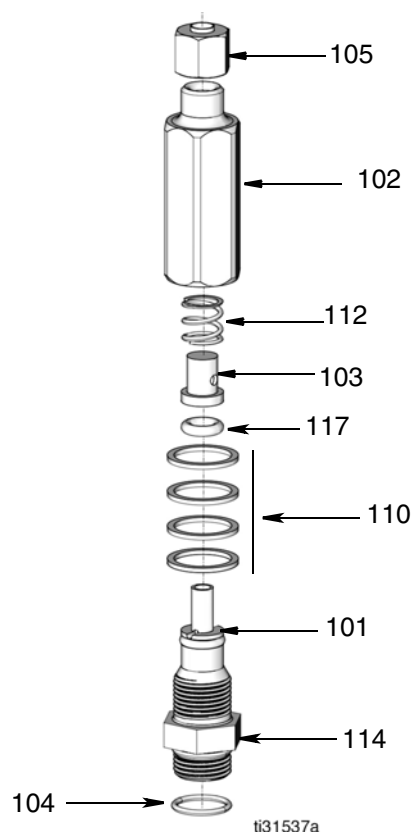

FIG. 36

Injector Dimensions

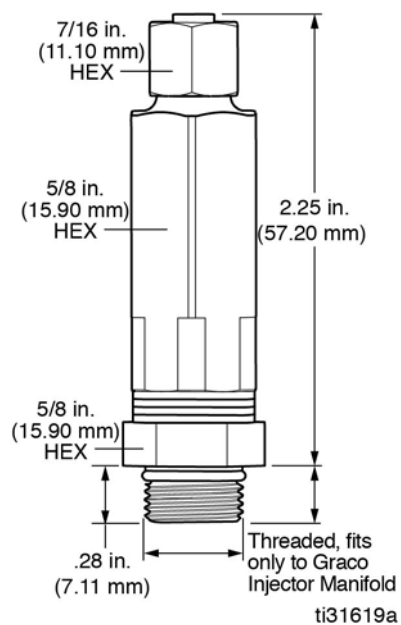

FIG. 37

Adjusting Grease Output Volume

Grease injectors are used to provide precise lubrication to each grease point in the system. If an injector is not producing the correct amount of lubricant for a specific location on the vehicle or if a replacement injector of correct size is not available, output spacer washers (110) can be installed to adjust the injector's output volume (FIG. 36, page 44).

Use the Injector Identification and Usage Table to determine which size injector is appropriate for the grease location.

| Injector Identification and Usage | | | | |
|-----------------------------------|---------------|-------------------|----------------------------|--|
| Part No. | Injector Size | Number of Washers | Output (in. ³) | Recommendations for Specific Lubrication Points |
| 24Z682 | 0 | 0 | 0.002 | Brake Shafts, transmissions, cross shafts, "S" cams |
| 24Z683 | 1 | 1 | 0.005 | Slack adjusters, 5th wheel pivot, and miscellaneous points |
| 24Z684 | 2 | 2 | 0.009 | Drag link, tie rod ends, power steering linkage |
| 24Z685 | 3 | 3 | 0.012 | King pins, spring pins, spring shackles |
| 24Z686 | 4 | 4 | 0.015 | Miscellaneous points |
| 24Z681 | 8* | 4 | 0.026 | 5th Wheel plate |

**Size 8 high output injectors cannot be changed.*

To change output volume:

1. If the injector is installed in the manifold:
 - a. **Relieve pressure**, page 11.
 - b. Remove the feed line. Use a 5/8" deep well socket to remove injector (101) from manifold (119/120) (FIG. 38).

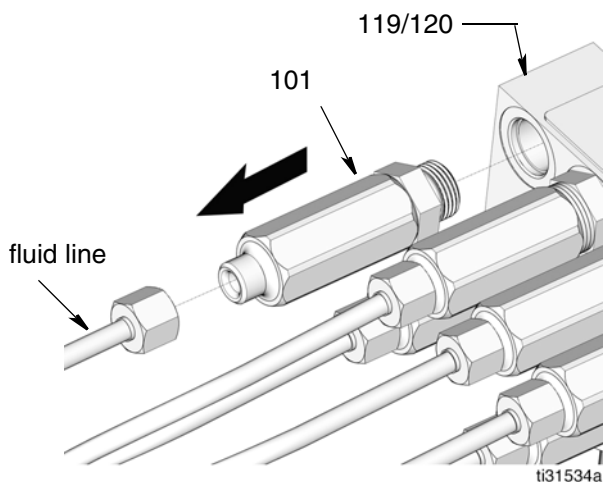

FIG. 38

For all injector adjustments:

2. Place injector (101) in a vise with outlet end (tube connector) facing up.

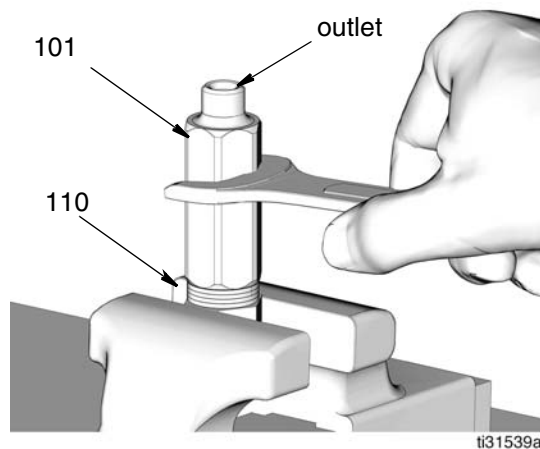

FIG. 39

3. Use a 5/8 inch wrench to loosen and separate the injector body (102) from the valve assembly (114). Be careful not to misplace or damage the spring (112), retainer cap (103) and o-ring (117) (FIG. 36, page 44).

Injectors

4. Add or remove output spacers (110) (FIG. 39, page 45) from the injector valve assembly.

NOTE:

- Add spacers (110) to increase output volume.
 - Remove spacers (110) to decrease output volume.
5. Reassemble injector valve assembly. Be sure all parts removed during disassembly are reinstalled in the correct order as shown in FIG. 36 (page 44). Use a 5/8" wrench to tighten using only enough force to seat output spacers firmly (110). Torque to 7.8 ft-lb (10.6 N•m).
 6. Install injector (101) onto manifold (119/120). Slide a deep well socket over the injector and aligned with the hex nut flats (114) (FIG. 36, page 44). Torque to 7.8 ft-lb (10.6 N•m).

2. Slide the manifold stem (121) through the hole (be sure the injectors are facing the lubrication points) (FIG. 40).
3. Slide washer (123) over the stem and screw nut (122) onto the stem (FIG. 40). Torque nut to 22 ft-lbs (29.83 N•m).

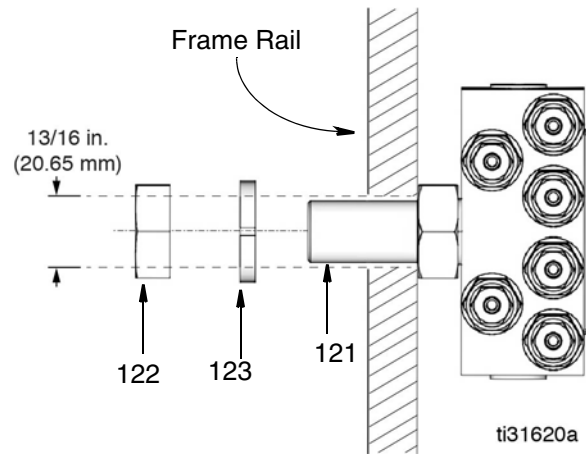
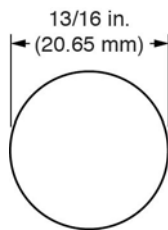

FIG. 40

Manifold Installation

- Mount all injector manifolds on the vehicle frame rail or a cross member close to the points they will be lubricating.
- Install injectors in locations that allow easy and safe servicing access.
- Install injectors in areas that minimize accidental injector damage by moving equipment.
- The unused ports in the manifolds should have plugs in them. If additional lube points are needed these plugs can be removed and replaced with appropriate sized injectors and lines.
- Group injectors to minimize feed line length.

1. Drill a 13/16 inch (0.812 mm) mounting hole through the frame rail or cross member.



Modules

NOTE: All installations may not include all points listed. The illustrations and instructions shown in the Modules section of this manual are provided for reference only. They may not be an exact representation of your truck or equipment. Lubrication points and locations are unique to each vehicle and installation will vary from vehicle to vehicle.

Front Left Module (FIG. 41)

| Point No. | Description | Injector Size | Tube Color | Bundle | Recommended Lube Point Fitting P/N |
|-----------|----------------|---------------|------------|-----------------|------------------------------------|
| 1 | KING PIN UPPER | 3 | Orange | 3-Tube | 556638 Elbow |
| 2 | TIE ROD | 2 | Black | | 15K740 Elbow and 556644 Connector |
| 3 | KING PIN LOWER | 3 | Blue | | 556638 Elbow |
| 4 | DRAG LINK | 2 | Orange | 2-Tube Unmarked | 15K740 Elbow and 556644 Connector |
| 5 | DRAG LINK | 2 | Black | | 15K740 Elbow and 556644 Connector |
| 6 | SPRING PIN | 3 | Black | Single | 556638 Elbow |
| 7 | PLUG | | | | |
| 8 | PLUG | | | | |
| 9 | SLACK ADJUSTER | 1 | Orange | 2-Tube #2 | 556638 Elbow |
| 10 | "S" CAM | 0 | Black | | 556638 Elbow |
| 11 | SPRING SHACKLE | 3 | Black | 2-Tube #1 | 556638 Elbow |
| 12 | SPRING SHACKLE | 3 | Orange | | 556638 Elbow |

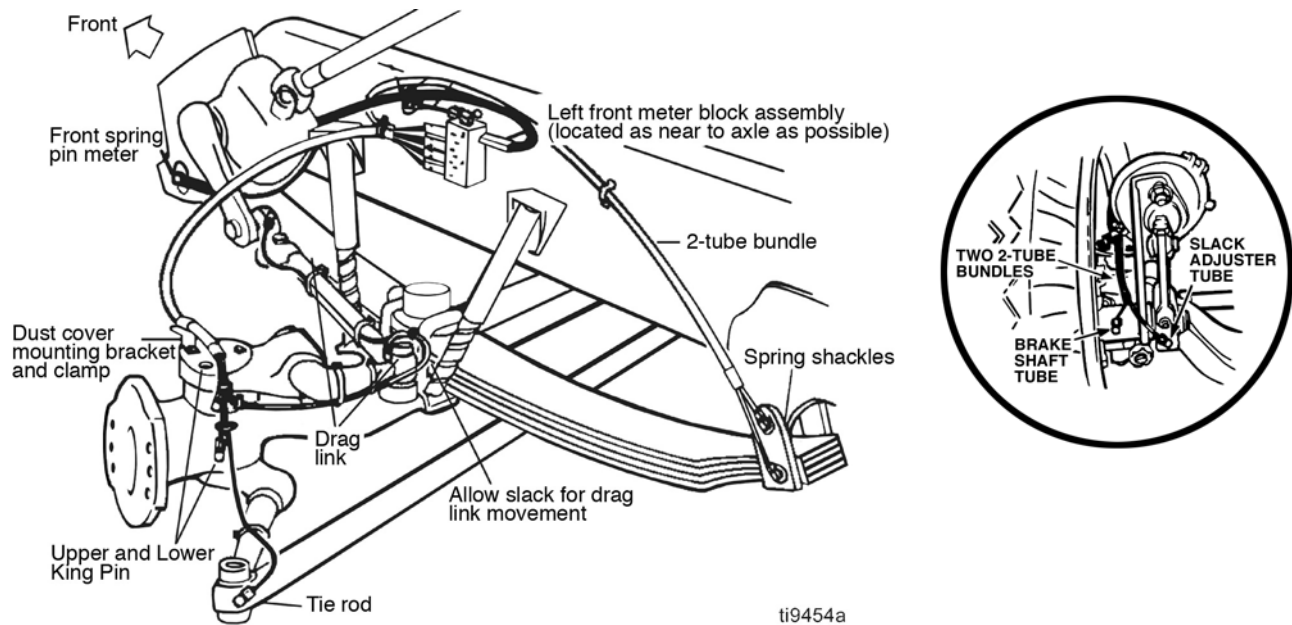

FIG. 41

Modules

Installation Instructions

1. Tie wrap the 3-tube bundle, 2-tube bundle and (2-tube #2, if present) marked bundle together as a group. These will follow the air brake line over the wheel area.
2. Use double-strap ties (Part No. 25C980) to attach tube to air brake line. Strap should be snug but not overtightened.
3. Anchor the first tie at frame fitting and the last tie of this bundle at the fitting on brake can. This will prevent strain on air hose.
4. Connect upper king pin first.
5. When routing lines to lower king pin and tie rod connection, make sure there is clearance away from the wheel.
6. Tie the tie rod line (black) to lower king pin fitting after the connection is made. Route the line up and over tie rod arm to loop over rear of tie rod end. This will reduce the chance of the line getting snagged by road debris.
7. Run spring hanger lube lines along side of frame attaching every 12-15 inches. After attaching first line to the upper fitting, secure the other lube line to that fitting then connect into the lower spring hanger. This assures that the lube line will travel with the hanger.
8. Route the lube line for the spring pin (black, single) so that it will be supported every 12-15 inches of travel.
9. The inlet for the module is through the stud. Use an elbow, Part No. 129755 or tee, Part No. 129759, depending on the routing of the main line. Alternate ports are on each end of the module.
10. **Optional:** Ports 7 & 8 on the modules are used for additional lube points. i.e., rear spring or clutch linkage.

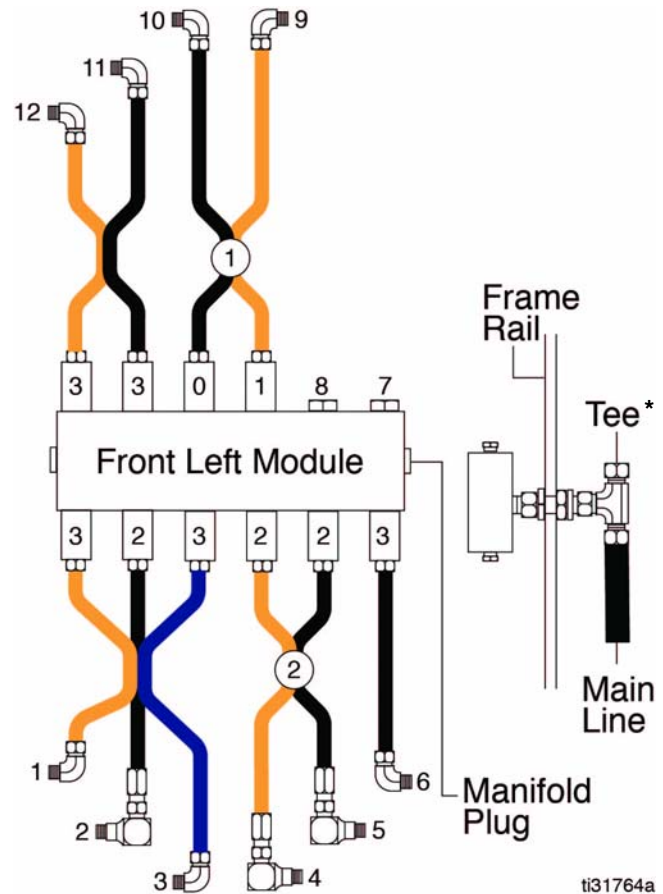

FIG. 42: *Tee 129759 shown. Can also use elbow 129755

Front Right Module (FIG. 43)

| Point No. | Description | Injector Size | Tube Color | Bundle | Recommended Lube Point Fitting P/N |
|-----------|-------------------|---------------|------------|-----------------|--------------------------------------|
| 1 | SPRING SHACKLE | 3 | Orange | 2-Tube #1 | 556638 Elbow |
| 2 | SPRING SHACKLE | 3 | Black | | 556638 Elbow |
| 3 | PLUG | | | | |
| 4 | PLUG | | | | |
| 5 | CLUTCH C/SHAFT LH | 0 | Black | 2-Tube Unmarked | 15K783 St Elbow and 556644 Connector |
| 6 | CLUTCH C/SHAFT RH | 0 | Orange | | 556638 Elbow |
| 7 | SPRING PIN | 3 | Black | Single | 556638 Elbow |
| 8 | SLACK ADJUSTER | 1 | Orange | 2-Tube #2 | 556638 Elbow |
| 9 | "S" CAM | 0 | Black | | 556638 Elbow |
| 10 | KING PIN LOWER | 3 | Blue | 3-Tube | 556638 Elbow |
| 11 | TIE ROD | 2 | Black | | 15K740 Elbow and 556644 Connector |
| 12 | KING PIN UPPER | 3 | Orange | | 556638 Elbow |

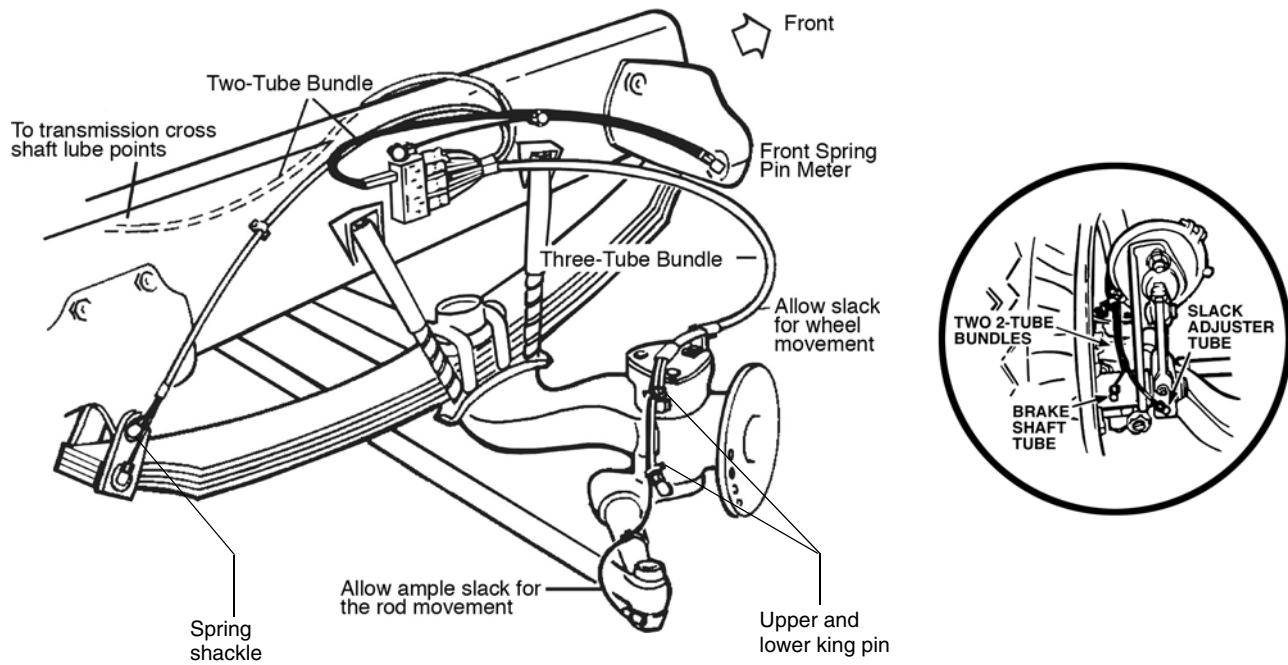

FIG. 43

Modules

Installation Instructions

1. Tie wrap the 3-tube bundle and 2-tube #2 marked bundle together as a group. These will follow the air brake line over the wheel area.

NOTE: Skip Step 1 if there is not a 2-tube #2 tube bundle required for your installation.

2. Use double-strap ties (Part No. 25C980) to attach tube to air brake line. Strap should be snug but not overtightened.
3. Anchor the first tie at frame fitting and the last tie of this bundle at the fitting on brake can. This will prevent strain on air hose.
4. Connect upper king pin first.
5. When routing lines to lower king pin and tie rod connection, make sure there is clearance away from the wheel.
6. The tie rod line (black) will be tied to lower king pin fitting after the connection is made. Route the line up and over tie rod arm to loop over rear of tie rod end. This will reduce the chance of the line getting snagged by road debris.
7. Run clutch lines under or through frame rail. Allow enough slack in line for drive train movement. The left cross shaft lube point may be easier to access by removing floor panel around shift base.
8. Run spring hanger lube lines along side of frame attaching every 12-15 inches. After attaching the first line to the upper fitting, secure the other lube line to that fitting. Then connect to the lower spring hanger. This assures that the line will travel with the hanger.
9. The lube line for the spring pin is black and single. Route the line so it will be supported every 12-15 inches of travel.
10. The inlet for the module is through the stud. Use an elbow, Part No. 556639 or tee, Part No. 556636, depending on the routing of the main line. Alternate ports are on each end of the module.
11. **Optional:** Ports 3 or 4 on the module are used for additional lube points. i.e., rear spring, assisted steering, throw out bearing.

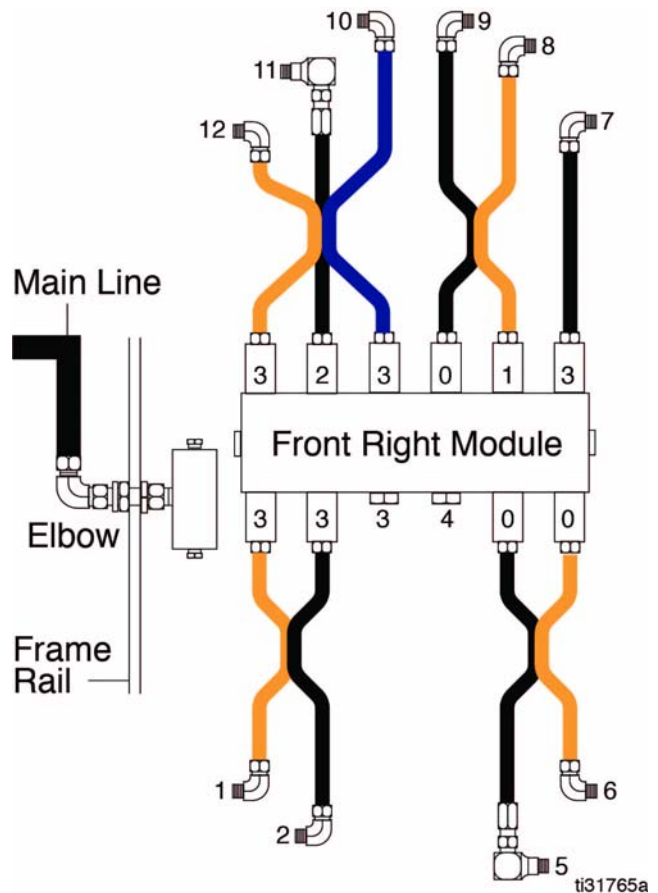

FIG. 44

Tandem Axle Module (FIG. 45)

| Point No. | Description | Injector Size | Tube Color | Bundle | Recommended Lube Point Fitting P/N |
|-----------|----------------|---------------|------------|-----------------|------------------------------------|
| 1 | PLUG | | | | |
| 2 | PLUG | | | | |
| 3 | "S" CAM | 0 | Black | 2-Tube Unmarked | 556638 Elbow |
| 4 | SLACK ADJUSTER | 1 | Orange | Unmarked | |
| 5 | "S" CAM | 0 | Black | 2-Tube Unmarked | |
| 6 | SLACK ADJUSTER | 1 | Orange | Unmarked | |
| 7 | SLACK ADJUSTER | 1 | Orange | 2-Tube Unmarked | |
| 8 | "S" CAM | 0 | Black | Unmarked | |
| 9 | SLACK ADJUSTER | 1 | Orange | 2-Tube Unmarked | |
| 10 | "S" CAM | 0 | Black | Unmarked | |
| 11 | PLUG | | | | |
| 12 | PLUG | | | | |

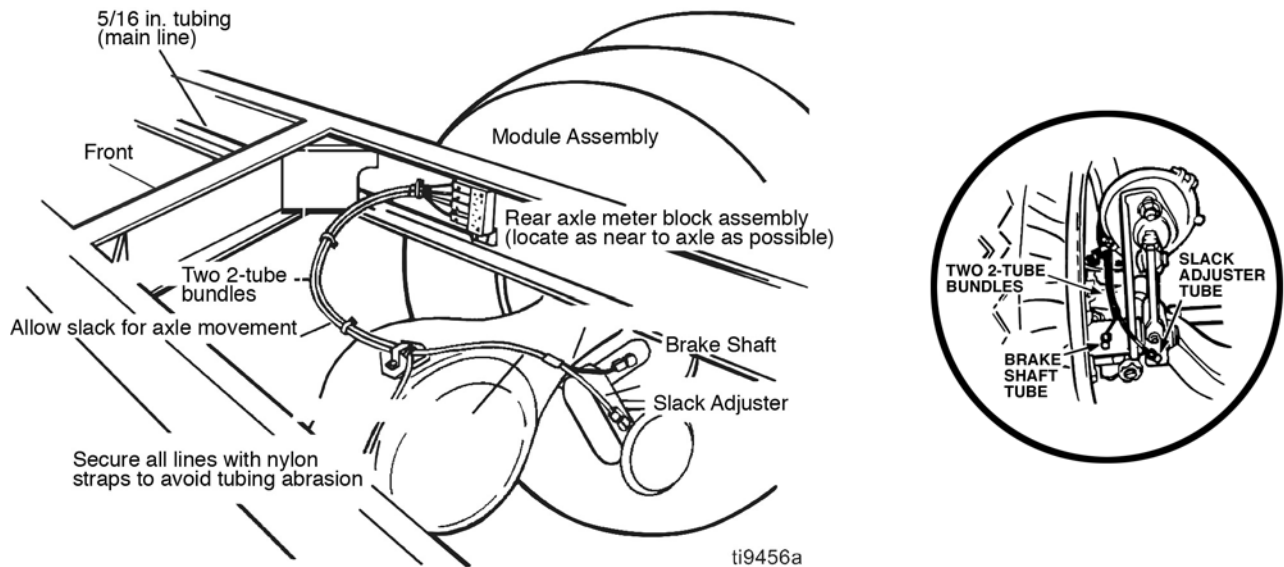

FIG. 45

Modules

Installation Instructions

1. Run each twin line to the brake slack adjuster and "S" cam following the air hoses from the control valve to the brake cams. This will allow for enough slack in the lines for axle movement.
2. Use double-strap ties (Part No. 25C980) to attach tube to air brake line. Strap should be snug but not overtightened.
3. Make sure the orange lines going to the slack adjusters have enough of a loop to allow movement of the actuator.
4. The main line connection is through an elbow, Part No. 556639 at one end. There may be a plug in the other end, another elbow or a straight fitting to allow grease to the next module.

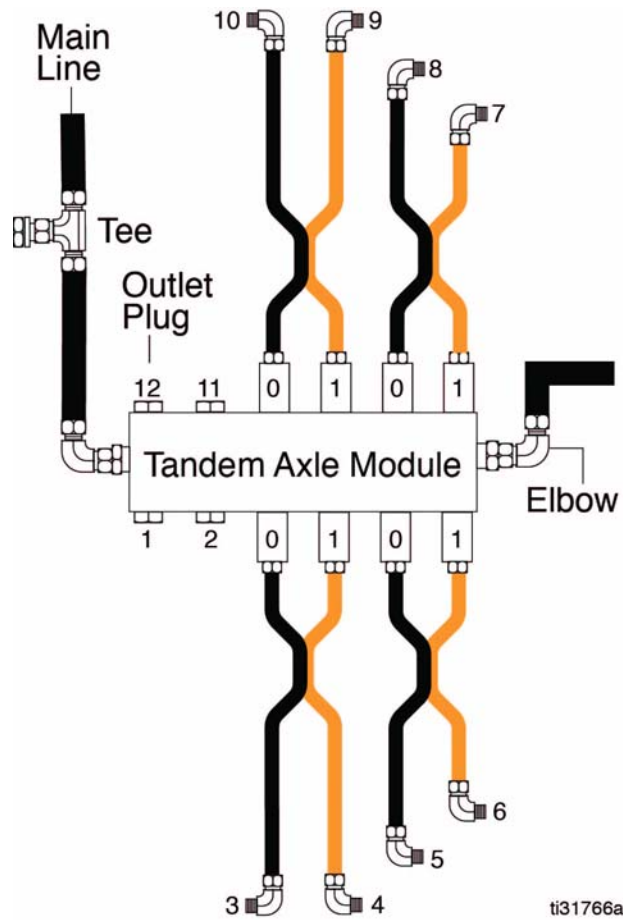

FIG. 46

5th Wheel Module (FIG. 47)

| Point No. | Description | Injector Size | Tube Color | Bundle | Recommended Fitting P/N |
|-----------|-------------------|---------------|------------|--------|-------------------------------------|
| 1 | FIFTH WHEEL PLATE | 8 | Orange | 3-Tube | 556644 Connector or 556638 Elbow |
| 2 | FIFTH WHEEL PIVOT | 1 | Black | | |
| 3 | FIFTH WHEEL PLATE | 8 | Blue | | |
| 4 | FIFTH WHEEL PLATE | 8 | Blue | 3-Tube | |
| 5 | FIFTH WHEEL PIVOT | 1 | Black | | |
| 6 | FIFTH WHEEL PLATE | 8 | Orange | | |

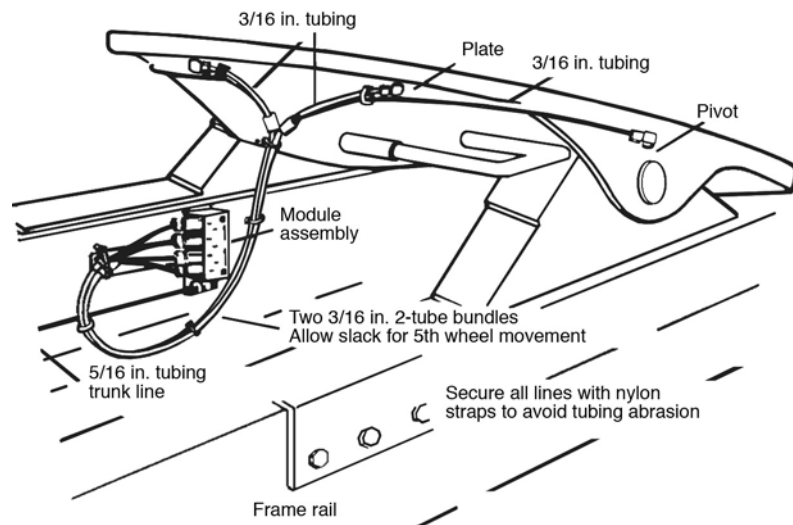

FIG. 47

Installation Instructions

1. Run orange lines and blue lines to the plate and the black lines to the pivot points. If there are more than 2 ports on the pivots, only 2 require auto lube.
2. Make sure the lines do not rub on the 5th wheel or its mounting components; the tubing can be pinched or wear through.

HINT: Wrap tubes with corrugated sheathing (user supplied) to protect the tube from rubbing.

3. The main line connection is through an elbow, Part No. 556640, at one end. There may be a plug in the other end, another elbow or a straight fitting to allow grease to the next module.

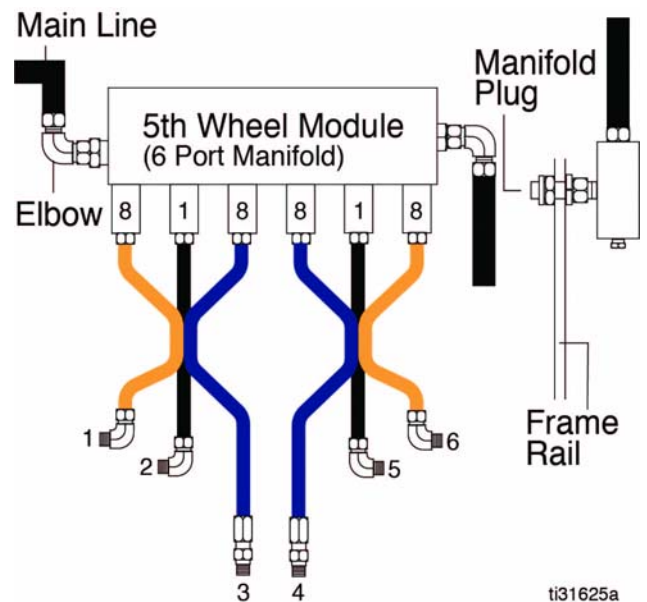

FIG. 48

Feed Line Tubes and Fittings

Feed Line Tubes and Fittings

Feed Line Tubes (H)

Feed line tubes (H) come pre-filled with grease. The following tube bundles may be included with the system. Other tube lengths are available from Graco. Contact your local Graco distributor or Graco Customer Support for assistance.

| Part No. | Bundle 10 feet (3.04 meters) | Bundle 15 feet (4.57 meters) | Color |
|----------|---------------------------------------|---------------------------------------|---------------------|
| 564086 | 1 tube | | Black |
| 563984 | 2 tubes | | Black, Orange |
| 563994 | 3 tubes | | Black, Orange, Blue |
| 563786 | | 1 tube | Black |
| 563788 | | 2 tubes | Black, Orange |
| 563783 | | 3 tubes | Black, Orange, Blue |

Feed Line Installation

NOTICE

- When installing the fluid lines avoid routing them close to a heat source such as an exhaust manifold, muffler, turbocharger, etc. Exposure to heat will damage the fluid lines.
- Non-approved nylon or air brake tubing should not be used. Only use the supplied fluid lines. Non-approved nylon or air brake tubing may not be designed for exposure to heat or excessive abrasion which can result in erosion, snagging or cutting of the tubing.

Always use approved 3/16 in. (4.76 mm) OD tubing. The 3/16 in. (4.76 mm) tubing comes in three configurations.

- Single tubes: black.
 - 2 tube bundles: black with a black and orange tube inside sheath.
 - 3 tube bundle: black, blue and orange tube inside a sheath.
- The orange tube is connected to the highest output injector.
- The blue tube is connected to a lesser or equal output injector.

- The black tube is connected to the lowest or equal output injector of the bundle group.

General Installation Instructions

NOTE: For specific installation instructions for each Module, see Left Front, Right Front, Rear and 5th Wheel Modules instructions beginning on page 47.

1. Measure approximate lengths of fluid line tubes (H), leaving extra length for trimming at the lube points.

NOTE: Allow ample slack for tube movement and ease of installation

2. Align fluid line with fitting.
3. Use a tubing cutter to cut the tube.
4. Insert the end of the fluid line tube into the injector ferrule.

NOTE: A self aligned ferrule is supplied with all 3/16 in. (4.76 mm) fittings. It is not necessary to remove the nut and ferrule to seat the tube into the fitting.

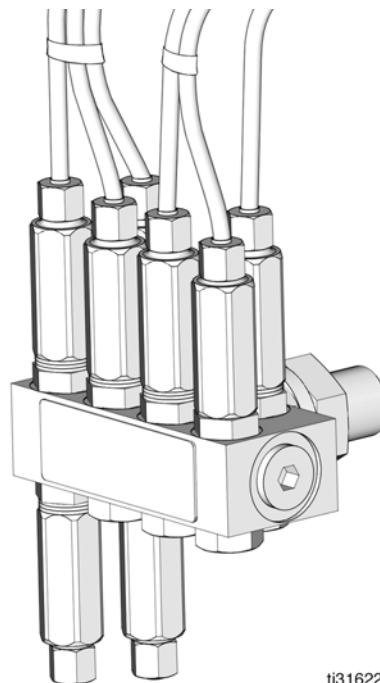

ti31622a

FIG. 49

Feed Line Tubes and Fittings

5. Make sure the tube is well seated into each fitting.

Hand tighten the tube nut onto the injector and tighten 1 full turn beyond hand tight. **DO NOT OVERTIGHTEN.**

NOTE: Tube nuts can be loosened and re-tightened a maximum of 8 times after the initial tightening. When re-tightening, only tighten 1/8 turn beyond hand tight.

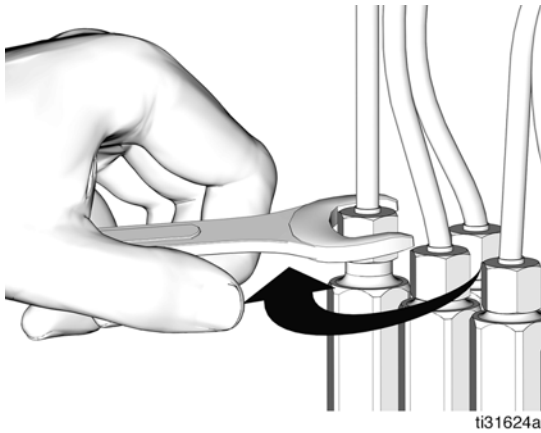

FIG. 50

Feed Line Fittings

Straight Connector - Part No. 556644



FIG. 51

Elbow Connector - Part No. 556638



FIG. 52

Street Elbow - Part No. 15K740



FIG. 53

Street Elbow - Part No. 15K783



FIG. 54

Main Line Hose

Main Line Hose

Temperature

Do not exceed the fluid and / or ambient temperature specifications of the hose. The approved temperature range for the hose is -56°F to 302°F (-49°C to 150°C).

Routing

NOTICE

- When installing the fluid lines avoid routing them close to a heat source such as an exhaust manifold, muffler, turbocharger, etc. Exposure to heat will damage the fluid lines.
- Route hoses to minimize exposure to hazards. Do not expose the hose to excessive abrasion which can result in erosion, snagging or cutting of the hose cover.
- Non-approved air brake hoses should not be used. Only use the supplied fluid lines. Non-approved air brake hoses may not be designed for exposure to heat or excessive abrasion which can result in erosion, snagging or cutting of the hose cover.
- Do not install in a location where the hose could be kinked, crushed or flattened.
- Do not create a bend radius smaller / tighter than 4 inches (101 mm).

Route hoses to ensure the relative motion of the equipment bends the hose. Do not allow the hose to twist.

Pressure Rating

2250 psi (15.5 MPa, 155.1 bar).

End Fitting

37-degree JIC, 9/16-180 UNF swivel.

Determining Main Line Hose Lengths

Electric Grease Jockey hoses are available in three lengths. One end is crimped in the factory the other end comes with a reusable fitting.

| Part No. | Length |
|----------|-----------------------|
| 17S968 | 6 feet (1.82 meters) |
| 17S969 | 12 feet (3.65 meters) |
| 17S970 | 18 feet (5.48 meters) |

After determining the final length of hose needed for the installation, install the reusable swivel fitting Part No. 131200 (included with the hose) to the bare end of the hose (see FIG. 55). Follow the Main Hose Assembly instructions provided in the next section of this manual (page 57).

To determine the overall length of hose needed for each fluid line:

1. Measure the distance between the pump and the injectors.
2. Add an additional 2% to the hose length to accommodate for change in length due to pressurizing the hose. The hose length shrinks when the hose is pressurized.

Example: A 100 in. (2.54 m.) hose will shrink to 98 in. (2.49 m) when pressurized.

3. Add 1.43 inches (36.30 mm) to the total hose length to accommodate the depth of the socket after it is installed on the end of the hose (FIG. 55).

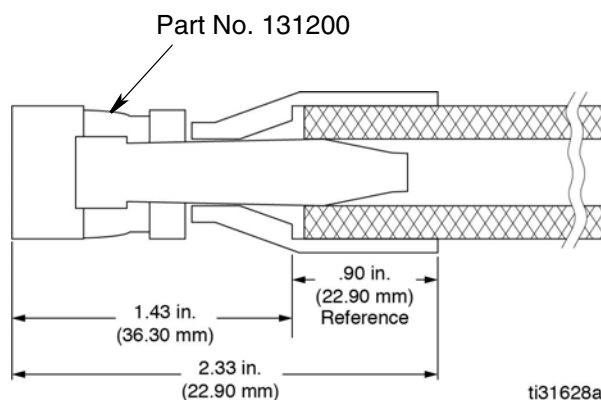

FIG. 55

Main Line Hose Assembly



SKIN INJECTION HAZARD

A hose that has been crushed or damaged in the vise may leak. High pressure fluid leaks will pierce skin. This may look like just a cut, but it is a serious injury that can result in amputation. Get immediate surgical treatment.

To reduce the risk of skin injection when testing or using the hose assembly:

- Inspect each hose assembly for cuts or damage.
- Verify that the hose assembly has not been crushed or damaged in the vise.
- Do not use a damaged hose assembly.

1. Secure end of hose in a vise (FIG. 56).

NOTE: Do not over tighten the vise and crush the hose. Vise should be just tight enough to hold the hose securely in place.

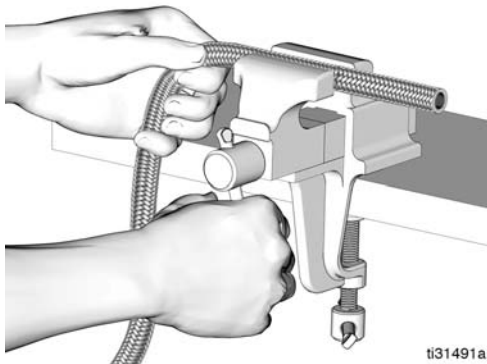

FIG. 56

2. Cut the hose square with a fine-tooth hacksaw or cut-off wheel (FIG. 57).

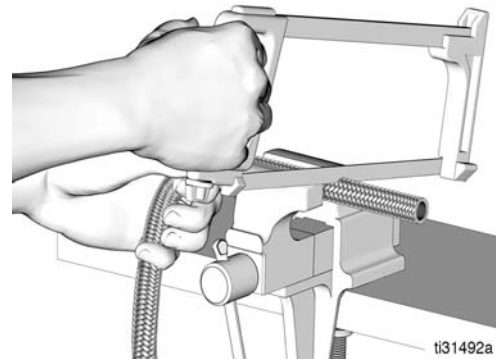

FIG. 57

3. Remove hose (b) from vise. Shake or lightly tap the cut end of it to remove debris and small hose pieces that resulted when cutting the hose.
4. Slide socket (a) over cut end of hose (b). Hand tighten socket to hose by turning socket counter-clockwise into hose (FIG. 58).

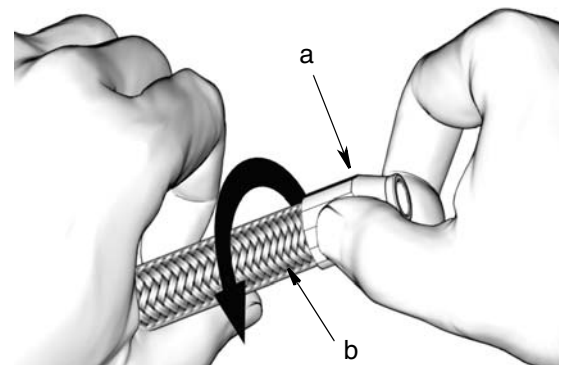

FIG. 58

5. Use a wrench to finish tightening socket (a) until it bottoms out. Then back off 1/4 turn to 1/2 turn (FIG. 59).

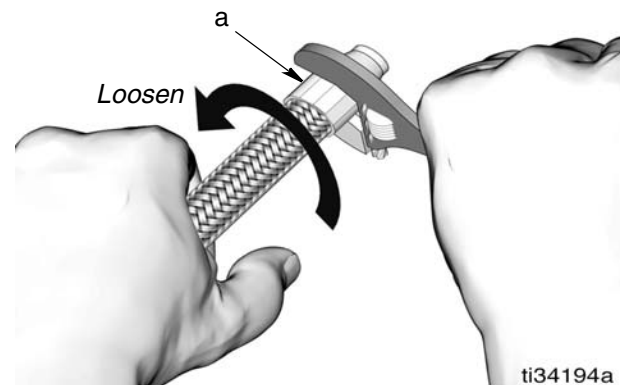

FIG. 59

Main Line Hose

6. Secure socket (a) in vise. Lubricate nipple (c) and threads liberally with grease.

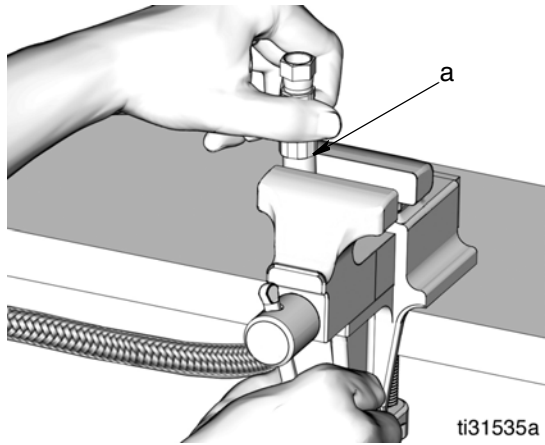

FIG. 60

7. Lightly push nipple (c) into socket (a). Screw nipple clockwise into socket and hose (FIG. 61).

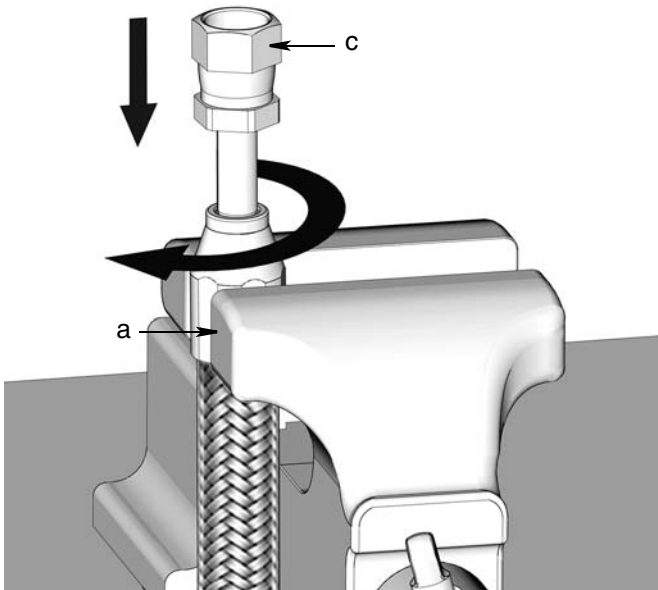

FIG. 61

8. Leave 1/32 to 1/16 inch (0.79 to 15.87 mm) clearance between socket (a) and hex (d) (FIG. 62).

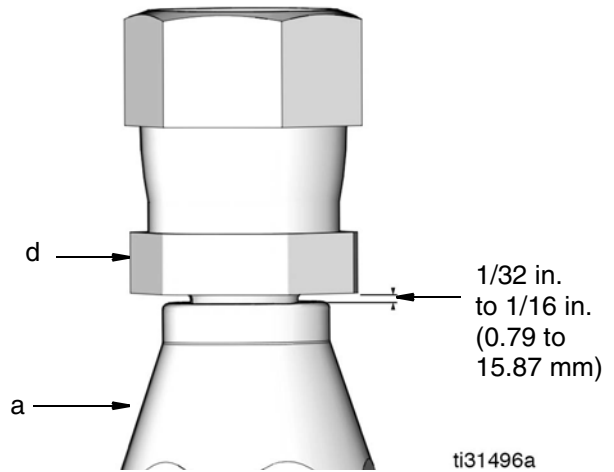

FIG. 62

Main Line Fittings

Straight Connector - Part No. 129763

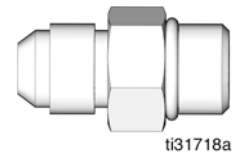

FIG. 63

Elbow Connector - Part No. 129755

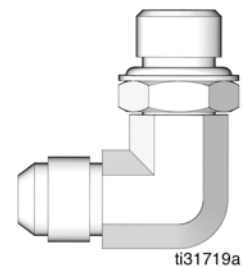

FIG. 64

Tee Fitting- Part No. 129759

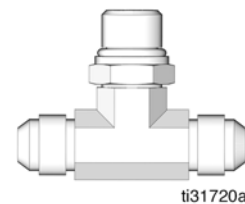







FIG. 65

System Starting and Operation

| | | | | |
|---|---|---|---|---|
|  |  |  |  |  |
| AUTOMATIC SYSTEM ACTIVATION HAZARD | | | | |
| <p>The system is equipped with an automatic timer that activates the pump lubrication system when power is connected or when exiting the programming function. Unexpected activation of the system could result in serious injury, including skin injection and amputation.</p> | | | | |
| <p>Before you install or remove the lubrication system components from the system, disconnect the battery and isolate all power supplies and relieve all pressure.</p> | | | | |

System Starting

After installing the pump, main line, feed line and modules, the system is ready to start.

Filling the Main Line



An automatic lubrication system must be free of air in order to generate enough pressure to discharge grease from the injectors. The main feed line must be filled with grease.

1. Remove a plug or injector from the top of each manifold assembly. Place a rag below the injector to capture excess grease.
2. Start the pump.
3. Watch for grease to come out of the manifold from the open outlet port (See Step 1). Allow grease to flow out of the port for up to one minute to be sure the grease is free of air and flowing freely.

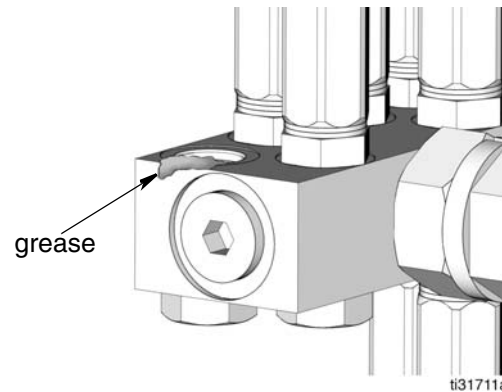

FIG. 66

4. Stop the pump.
5. Reinstall injector in outlet port. Torque to 7.8 ft.-lbs (10.6 N•m).
6. The system is now ready.

Operation

The following steps describe a typical lubrication cycle.

1. The pump starts.
 2. The paddle stirs the grease in the reservoir.
 3. The vent valve closes. Pressure builds in the system to approximately 1900 psi (13.1 MPa, 131 bar) dispensing grease to all injectors in the system and providing lubrication to all lubrication points on the vehicle.
- NOTE:** The controller is factory set to seven minutes ON time. This will provide the pump with ample time to reach the maximum pressure; approximately 1900 psi (13.1 MPa, 131 bar).
4. If there is any additional ON time (i.e., time remaining after building to approximately 1900 psi (13.1 MPa, 131 bar) the relief valve opens, relieving pressure in the system back to the reservoir.
 5. After the pump stops pumping grease. The vent valve opens, allowing grease and pressure in the fluid lines to flow back into the pump reservoir. The injectors reset.
 6. The pump rests (OFF time) for 2 hours and 53 minutes.

System Starting and Operation

NOTE: This the factory set OFF time.

7. The cycle then repeats.

NOTE: See Programming the Pump, page 21 for instructions to increase or decrease cycle time.

Typical Cycle

The illustration shown in FIG. 67 shows a typical pump cycle.

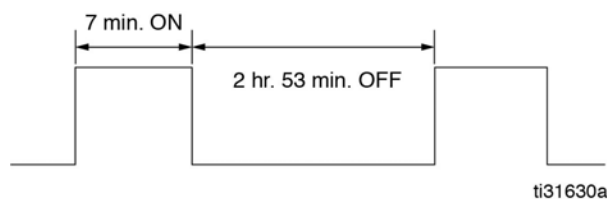

FIG. 67

Troubleshooting



| Problem | Cause | Solution |
|---|--|---|
| Too much grease at all lube points | Lube cycle too frequent | Increase pump OFF/rest time. |
| Too much grease at one lube point | Injector is leaking | Remove and replace injector |
| Not enough grease at all lube points | Lube cycle is too infrequent | Decrease pump OFF /rest time. |
| No sign of fresh grease at all points | No grease, pump low level | Fill pump. |
| | Blown fuse or break in wiring circuit. Pump not working. | Check for electrical short circuit or broken wire, and repair. |
| | Main line broken | Check and replace Main Line Hose. |
| | Worn pump element and/or vent valve. | Using a 2500 psi (17.24 MPa, 172.4 bar) pressure gauge, check for pressure. The pump pressure should build to approximately 1900 psi (13.1 MPa, 131 bar). If it does not reach approximately 1900 psi (13.1 MPa, 131 bar) replace pump element and/or vent valve. |
| No sign of fresh grease at some lube points | Main line broken | Check and replace main line hose. |
| | Air lock in main line | Purge air from main line; page 59. |
| No sign of fresh grease at one lube point | Feed line damaged | Replace feed line. |
| | Injector inoperative | Replace injector. |
| | Lube point fitting has broken off | Remove broken fitting and replace |
| Main line damaged | Trapped and broken, rubbed through | Replace (re-route and/or protect the line to prevent the damage from happening again). Purge with grease to expel air before connecting new main line into system. |
| Feed line damaged | Hose is kinked, pinched, broken or punctured | Replace (re-route and/or protect the line to prevent the damage from happening again). |
| | Feed line has detached out of fitting | Refit line to the fitting using a new compression nut. |
| | Broken or damaged feed line fitting | Remove broken fitting and replace. |
| Unit does not power on | Incorrect/loose wiring | Refer to Installation instructions, page 5. |
| | Tripped external fuse due to internal component failure | Replace pump. |
| Pump runs continuously | Pump is not wired correctly | Check wiring. See Pump Wiring, page 14. Check for short circuit. |
| Can't set desired ON/OFF times | Maximum duty cycle is 33% (2 minutes OFF for each minute ON) | Adhere to allowable duty cycle. |

Troubleshooting

| Problem | Cause | Solution |
|---|---|---|
| Unit is not operating based on the time that was programmed | Time entered was misinterpreted as MM:SS instead of HH:MM (or visa versa) | Verify the unit was programmed as intended. See Programming the Pump, page 20. Note the dot designation for hours, minutes, seconds on the top row of the display. |
| Lubricant leaks past seal located on the bottom of the reservoir | Reservoir retaining tabs are cracked or broken | Replace reservoir. |
| | Reservoir is being pressurized during filling | Ensure vent hole is not plugged. |
| | Reservoir is being pressurized during filling due to rapid filling or overfilling reservoir | Ensure vent hole is not plugged. Fill reservoir slowly. Do not overfill reservoir and main line hose. |
| Pump stirring paddle is not rotating and pump is not pumping during ON cycle, but controller lights and functions | Failed motor | Replace pump. |
| Pump takes several minutes before it begins pumping | Pumping non-cold weather lubricant in cold weather | Adjust lube cycle time to accommodate the difference in pump run time. or Replace lubricant in pump, main line hose and fluid lines with pumpable lubricant, rated for environmental conditions and application. |
| USB Error 00 | Flash drive was removed during operation | Keep the flash drive plugged in until the unit has completed the operation. |
| USB Error 07 | Flash drive unable to mount (initialize) | <ul style="list-style-type: none"> Unplug the flash drive and re-install. Cycle power and re-install the flash drive. Retry using a different flash drive. If any of the above do not rectify the error, contact Graco Customer Service. |
| USB Error 11 | Pump program setting file not found | Verify that the pump program setting folder structure and file are stored correctly on the flash drive. See Storing Pump Program Settings to the Flash Drive, page 25 for instructions. |
| USB Error 12 | Pump program settings directory not found. | Verify that the pump program setting folder structure and file are stored correctly on the flash drive. See Storing Pump Program Settings to the Flash Drive, page 25 for instructions. |

| Problem | Cause | Solution |
|----------------------|---|--|
| USB Error 13 | Bad pump program settings file | The pump programs settings file is corrupt. Restore file to the flash drive. See Storing Pump Program Settings to the Flash Drive, page 25 for instructions. |
| | Setting file is from different firmware version | Program pump manually or recreate settings file from a pump that has the same firmware version. See Storing Pump Program Settings to the Flash Drive, page 25. |
| All other USB errors | | <p>The following operations can be attempted if another error occurs using the USB.</p> <ul style="list-style-type: none">• Unplug the flash drive and re-install.• Cycle power and re-install the flash drive.• Retry using a different flash drive. <p>If any of the above do not rectify the error, contact Graco Customer Service.</p> |

Maintenance

Maintenance

| Frequency | Component | Required Maintenance |
|---------------------|-------------------------|--|
| Daily and at refill | Refill Fitting | Keep refill fitting clean by covering it with dust cap (26) when not in use. Clean refill fitting using a clean dry cloth. Dirt and/or debris can damage pump and/or lubrication system. |
| Weekly | Pump Unit and Reservoir | Keep pump unit and reservoir clean using a clean dry cloth. |
| | Display | Keep display clean using a clean dry cloth. |
| Monthly | External Wiring Harness | Verify external harnesses are secure. |
| | Lube Points | Open feed line tube and check for fresh grease. |
| | Pump | Check for operation and grease level in reservoir. |

Changing Greases

Always verify compatibility before mixing two greases together.

Technical Specifications

| Grease Jockey Automatic Lubrication System | | |
|---|---|---|
| | US | Metric |
| Maximum fluid working pressure | 2000 psi | 13.79 MPa, 137.9bar |
| Fluid | Grease NLGI 000 - #2 | |
| Grease Jockey Pump | | |
| Pump Output Pressure | 2000 psi | 13.79 MPa, 137.9bar |
| Power | | |
| 12 VDC | 9 - 16 VDC; 7 A current, 84 W, inrush/locked rotor 12 A | |
| 24 VDC | 18 - 32 VDC; 4A current, 96 W, inrush/locked rotor 6 A | |
| Vent Valve | | |
| Vent Valve Type | Normally open (vents pressure back to reservoir during pump OFF/rest time) | |
| Power | | |
| 12 VDC | 1.6 A current, 19 W | |
| 24 VDC | 0.8 A current, 19 W | |
| Pump Elements | 1 | |
| Pump Output | 0.6 in. ³ / minute per outlet | 9.8 cm ³ / minute per outlet |
| Pump Outlet | 9/16-18, -6 SAE ORB | |
| Reservoir Size | 2 Liters | |
| IP Rating | IP69K | |
| Weight (Dry - includes power cord and plug) | 13.3 lbs | 6.03 kg |
| Wetted Parts | nylon 6/6 (PA), amorphous polyamide, zinc plated steel, carbon steel, alloy steel, stainless steel, nitrile rubber (buna-N), bronze, nickel plated alnico, chemically lubricated acetal, aluminum, PTFE | |
| Sound Data | <60 dB | |
| Main Fluid Line Hose | | |
| Maximum Hose Pressure | 2250 psi | 15.5 MPa, 155.1 bar |
| Ambient and Fluid Temperature | -56°F to 302°F | -49°C to 150°C |
| Minimum Bend Radius | 4 inches | 10.1 cm |
| Hose Fitting | 37° female JIC-6 swivel (9/16-18 UNF Threaded) | |
| Hose ID | 5/16 inch | |
| Wetted Parts | AQP elastomer tube, polyester inner braid, single wire braid reinforcement, blue polyester braid cover | |
| Weight - hose alone without fittings | 0.23 lbs / foot | 0.27 kg / meter |

Technical Specifications

| Grease Jockey Automatic Lubrication System | | |
|---|--|-----------------------|
| | US | Metric |
| Injectors | | |
| Maximum Operating Pressure | 2000 psi | 13.79 MPa, 137.9bar |
| Minimum Operating Pressure | 450 psi | 3.2 MPa, 31.5 bar |
| Reset Pressure | 250 psi | 1.72 MPa, 17.24 bar |
| Output Volume per Cycle | | |
| Size 0 injector | 0.002 cu. in. | 0.033 cm ³ |
| Size 1 injector | 0.005 cu. in. | 0.082 cm ³ |
| Size 2 injector | 0.009 cu. in. | 0.15 cm ³ |
| Size 3 injector | 0.012 cu. in. | 0.19 cm ³ |
| Size 4 injector | 0.015 cu. in. | 0.25 cm ³ |
| Size 8 injector | 0.026 cu. in. | 0.43 cm ³ |
| Wetted Parts | aluminum, nitrile rubber (buna-N0, brass, carbon steel, alloy steel) | |
| Feed Line Tubing | | |
| Outside Diameter | 3/16 inch | |
| Maximum Operating Pressure | 800 psi | 5.5 MPa, 55 bar |

Graco Standard Warranty

Graco warrants all equipment referenced in this document which is manufactured by Graco and bearing its name to be free from defects in material and workmanship on the date of sale to the original purchaser for use. With the exception of any special, extended, or limited warranty published by Graco, Graco will, for a period of twelve months from the date of sale, repair or replace any part of the equipment determined by Graco to be defective. This warranty applies only when the equipment is installed, operated and maintained in accordance with Graco's written recommendations.

This warranty does not cover, and Graco shall not be liable for general wear and tear, or any malfunction, damage or wear caused by faulty installation, misapplication, abrasion, corrosion, inadequate or improper maintenance, negligence, accident, tampering, or substitution of non-Graco component parts. Nor shall Graco be liable for malfunction, damage or wear caused by the incompatibility of Graco equipment with structures, accessories, equipment or materials not supplied by Graco, or the improper design, manufacture, installation, operation or maintenance of structures, accessories, equipment or materials not supplied by Graco.

This warranty is conditioned upon the prepaid return of the equipment claimed to be defective to an authorized Graco distributor for verification of the claimed defect. If the claimed defect is verified, Graco will repair or replace free of charge any defective parts. The equipment will be returned to the original purchaser transportation prepaid. If inspection of the equipment does not disclose any defect in material or workmanship, repairs will be made at a reasonable charge, which charges may include the costs of parts, labor, and transportation.

THIS WARRANTY IS EXCLUSIVE, AND IS IN LIEU OF ANY OTHER WARRANTIES, EXPRESS OR IMPLIED, INCLUDING BUT NOT LIMITED TO WARRANTY OF MERCHANTABILITY OR WARRANTY OF FITNESS FOR A PARTICULAR PURPOSE.

Graco's sole obligation and buyer's sole remedy for any breach of warranty shall be as set forth above. The buyer agrees that no other remedy (including, but not limited to, incidental or consequential damages for lost profits, lost sales, injury to person or property, or any other incidental or consequential loss) shall be available. Any action for breach of warranty must be brought within two (2) years of the date of sale.

GRACO MAKES NO WARRANTY, AND DISCLAIMS ALL IMPLIED WARRANTIES OF MERCHANTABILITY AND FITNESS FOR A PARTICULAR PURPOSE, IN CONNECTION WITH ACCESSORIES, EQUIPMENT, MATERIALS OR COMPONENTS SOLD BUT NOT MANUFACTURED BY GRACO. These items sold, but not manufactured by Graco (such as electric motors, switches, hose, etc.), are subject to the warranty, if any, of their manufacturer. Graco will provide purchaser with reasonable assistance in making any claim for breach of these warranties.

In no event will Graco be liable for indirect, incidental, special or consequential damages resulting from Graco supplying equipment hereunder, or the furnishing, performance, or use of any products or other goods sold hereto, whether due to a breach of contract, breach of warranty, the negligence of Graco, or otherwise.

FOR GRACO CANADA CUSTOMERS

The Parties acknowledge that they have required that the present document, as well as all documents, notices and legal proceedings entered into, given or instituted pursuant hereto or relating directly or indirectly hereto, be drawn up in English. Les parties reconnaissent avoir convenu que la rédaction du présente document sera en Anglais, ainsi que tous documents, avis et procédures judiciaires exécutés, donnés ou intentés, à la suite de ou en rapport, directement ou indirectement, avec les procédures concernées.

Graco Information

For the latest information about Graco products, visit www.graco.com.

For patent information, see www.graco.com/patents.

TO PLACE AN ORDER, contact your Graco distributor or call to identify the nearest distributor.

Phone: 612-623-6928 or Toll Free: 1-800-533-9655, Fax: 612-378-3590

All written and visual data contained in this document reflects the latest product information available at the time of publication. Graco reserves the right to make changes at any time without notice.

Original instructions. This manual contains English. MM 3A5082

Graco Headquarters: Minneapolis

International Offices: Belgium, China, Japan, Korea

GRACO INC. AND SUBSIDIARIES • P.O. BOX 1441 • MINNEAPOLIS MN 55440-1441 • USA
Copyright 2017, Graco Inc. All Graco manufacturing locations are registered to ISO 9001.

www.graco.com
revised, October 2018