

Fluid Automation F4 Series

335029C

EN

For metering, mixing, and dispensing multiple component silicone materials.
For professional use only.

Not approved for use in explosive atmospheres or hazardous locations.

For models:

F4-5

F4-55

F4-55-5

Refer to the Fluid Automation F4 Series Setup-Operation manual 335028 for maximum working pressure and model information.



Important Safety Instructions

Read all warnings and instructions in the Fluid Automation F4 Series Setup-Operation manual 335028. Save all instructions.

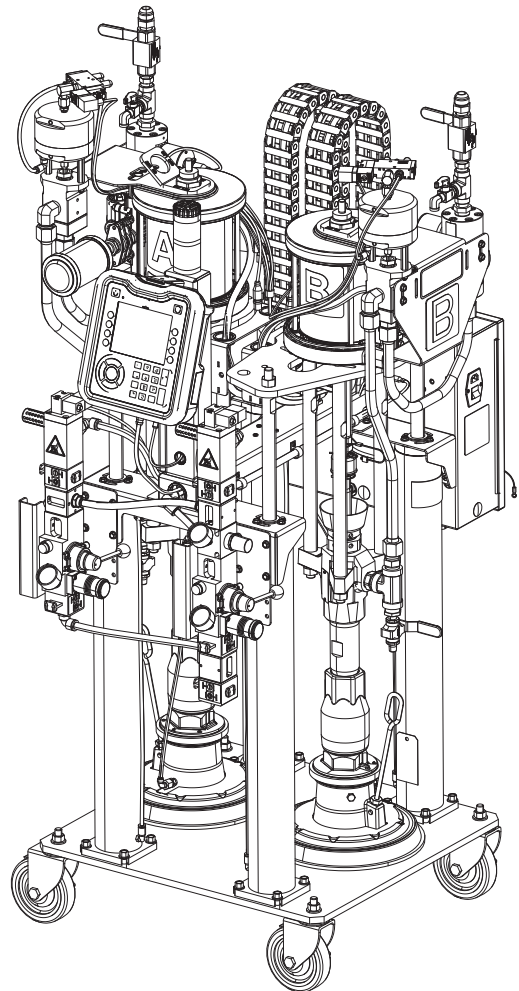

Contents

Contents	2
Related Manuals	3
F4-5 Base Model	4
F4-5 System - 24X160	4
F4-5 Base/Ram - 24X281	8
F4-5 Ram Air Cylinder - 24W784	10
Air-Line Bracket Assembly - 25A073	12
F4-5 Platen - 25A206	14
F4-55 Base Models	16
F4-55 System - 24X167 and 24X169	16
F4-55 Platen - 25A230	21
F4-55-5 System - 24X166 and 24X168	22
F4-55 and 55-5 Base/Ram - 24X185	24
F4-55 and 55-5 Ram Air Cylinder - 24X175 ...	26
F4-55 and 55-5 Air Line Bracket Assembly - 25A069	28
Common Parts	30
Main Integrated Air Control - 24X187	30
Secondary Integrated Air Control - 24X286 ...	32
A and B Pump Assemblies	34
Electronic Enclosure (Control Module) - 24X186	37
Hoses	41
Graco Standard Warranty	42
Graco Information	42

Related Manuals

Manuals are available at www.graco.com. Component manuals below are in English:

System Manuals	
335028	Fluid Automation F4 Series Instructions - Setup-Operation
3A3103	Fluid Automation F4 Series Instructions - Kits-Accessories
Ram Manuals	
3A0233	Air-Powered Ram Instructions - Parts
Pump Manuals	
312375	Check-Mate® Displacement Pumps Instructions - Parts
Air Motor Manuals	
3A1211	SaniForce® Air Motors Instructions - Parts
Flow Meter Manuals	
308778	Volumetric Fluid Flow Meter Instructions - Parts
309834	Helical Gear Fluid Flow Meters Instructions - Parts
Air Controls	
312374	Air Controls Instructions - Parts
Reference Manuals	
3A1244	Graco Control Architecture™ Module Programming
Valve Manuals	
313342	Dosing Valve Instructions - Parts

F4-5 Base Model

F4-5 System - 24X160

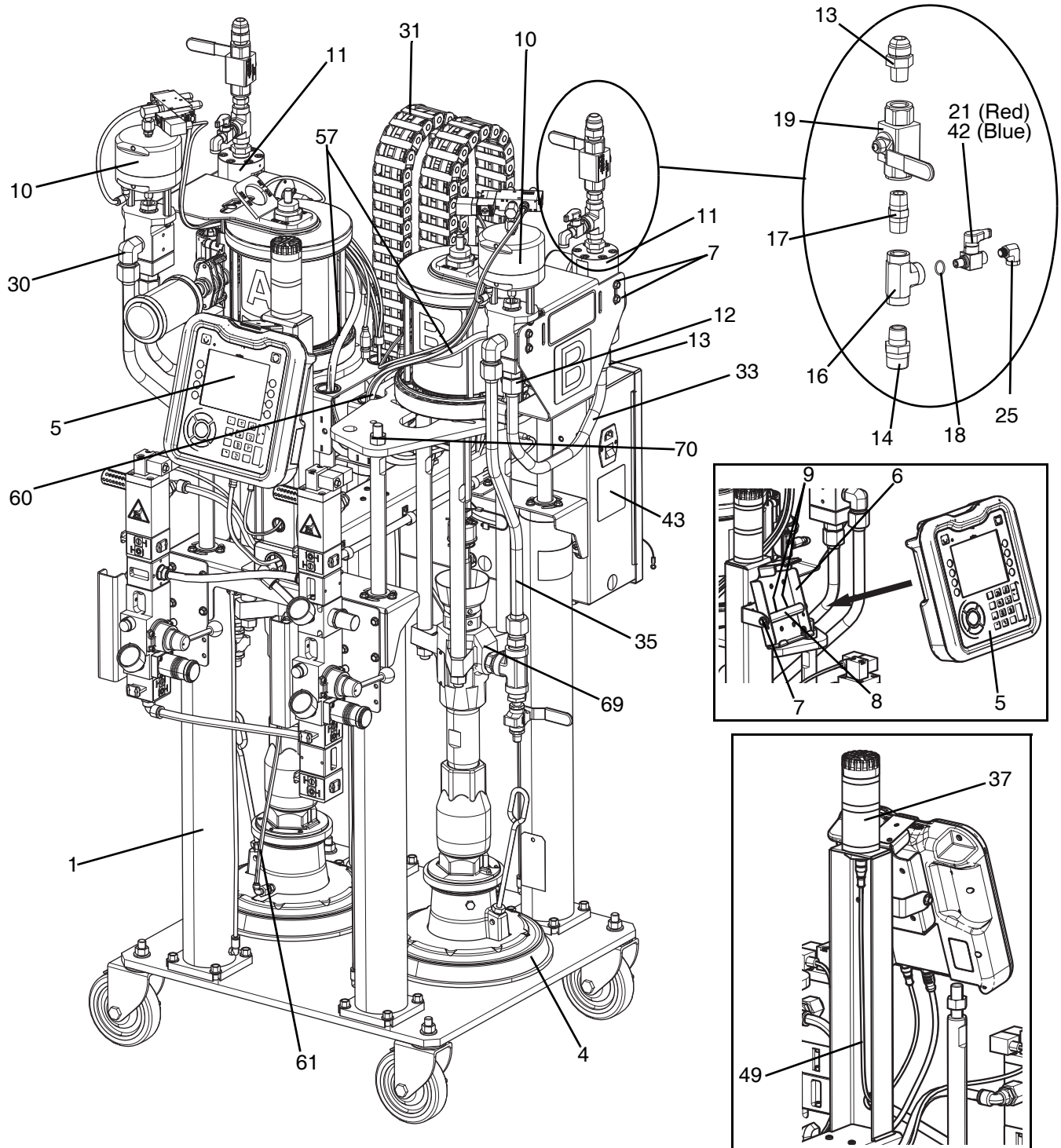

FIG. 1: F4-5 Model Front View

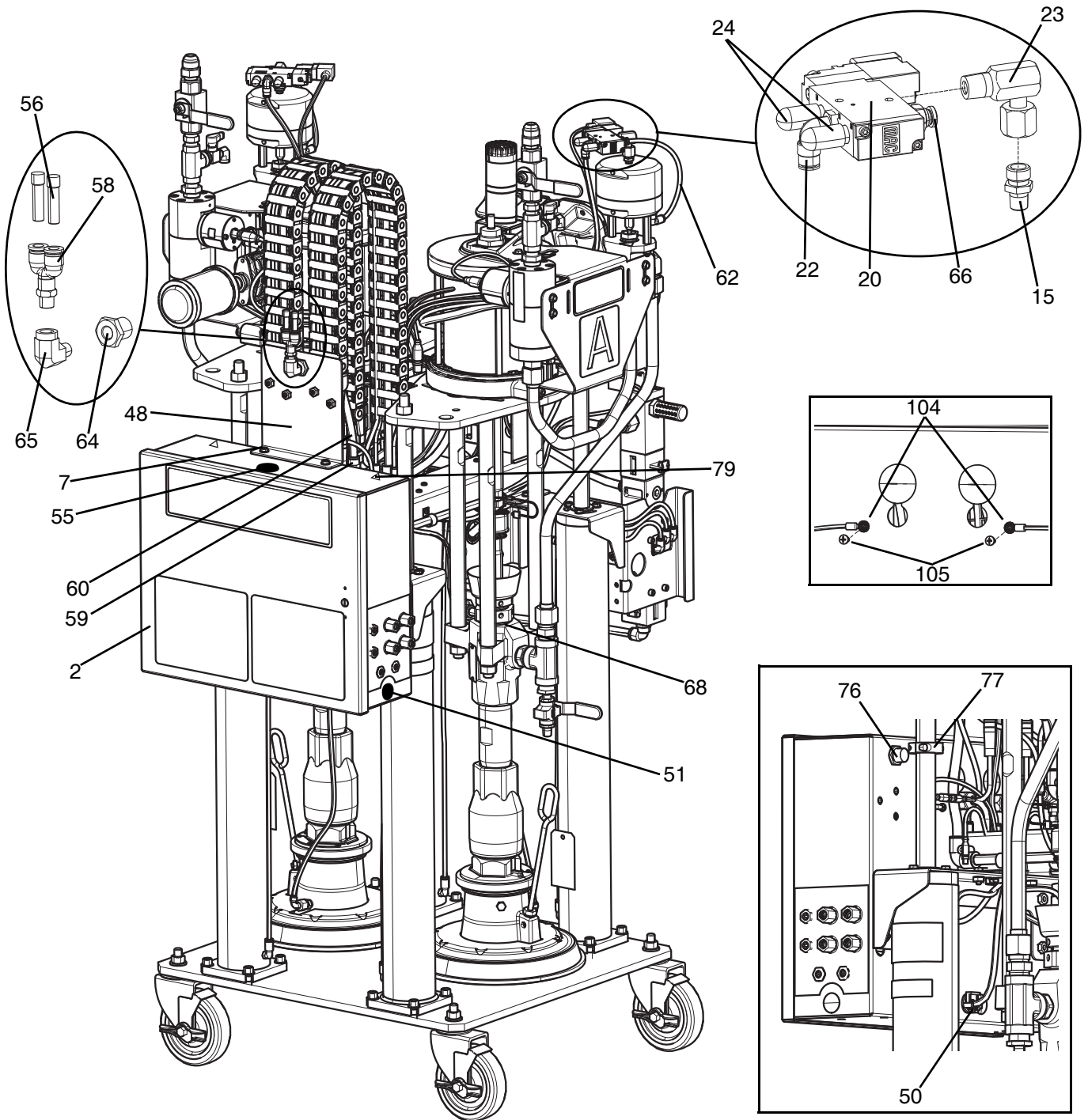

FIG. 2: F4-5 Model Rear View

Ref	Part	Description	Quantity
1	---	RAM, dual, 5 gal	1
2	---	MODULE, controls	1
4	25A206	KIT, plate, 20 l, single wiper, ptfе	2
5	25A171❖	KIT, adm, lsr f4	1
6	255235	BRACKET, mounting, assembly	1
7	114182	SCREW, mach, hex flange	18
8	17A532	BAR, bracket, dm	1
9	120885	SCREW	2
10	24W994★	VALVE, assy, ratio control, ss	2
11	246652	METER, heli gear, hi resolution	2
12	15M863	FITTING, connector, male	2
13	94/1027/98	ADAPTER, jic 12 x 1/2 npt, mm, ss, 3k, 316	4
14	16R883	FITTING, nipple, reducing, 3/4 x 1/2	2
15	191872	FITTING, adapter	2
16	128309	FITTING, tee, 1/2 npt, fxfxf, ss	2
17	114373	FITTING, nipple, 1/2 npt, sst hex	2
18	128055	FITTING, bushing, 1/2 npt x 1/8 npt, ss	2
19	262739	VALVE, 1/2 in. ball	2
20	127356	VALVE, power, 5/2, 24 vdc	2
21	256459	KIT, a side valve	1
22	121022	FITTING, elbow, male, 1/4 npt	2
23	155541	FITTING, swivel, 90 degree	2
24	512909	MUFFLER, polyethylene	4
25	128054	FITTING, elbow, st, 90, 1/8 npt, ss	2
30	94/1035/98	ADAPTER, elbow, 90, jic 12 x 1/2 npt, mm	2
31	24X638	GUIDE, cable, hose	2
33	17D355	TUBE, valve, xm, flow meter	2
35	17D354	TUBE, valve, xm, outlet	2
37	127187	LIGHT, tower, 30 mm, red/grn/alarm	1
40	17C706*	SOFTWARE, gca, lsr	1
42	256460	KIT, b side valve	1
43	---	BLANK, label, kit, 3x3	1
48	24X522	BRACKET, white	1
49	128308	CABLE, gca, m12 x m12, 4-pin x 4-pin	1
50	124005	BUSHING, strain relief	1
51	123812	PLUG, hole, .875 in.	3
55	128213	PLUG, hole, 1.250 in.	1
56	124419	PLUG, tube, push, 3/8 in.	2
57	25A036	CABLE, gca, sig, assy, pump	2
58	128052	FITTING, wye, 1/4 npt x 3/8 tube	1
59	122848	FITTING, air	2
60	61/2908-BK/11	TUBE, 0.320 id x 0.500 od, pu, 95 dur,	5.5

61	61/2904-RD/11	TUBE, 0.160 id x 0.250 od, pu, 95 dur,	6.7
62	61/2904-BK/11	HOSE, .160 id x .250 od, pu, 95 dur	6.7
64	94/0508/96	FITTING, bulkhead, 1/4 npt, f, brs	1
65	94/0506/96	FITTING, elbow, str, 1/4 npt, 90, brs	1
66	94/0701/96	CONNECTOR, 1/4 tube x 1/4 npt, m, brs	2
68	25A092	PUMP, assembly, 40:1, a side	1
69	25A093	PUMP, assembly, 40:1, b side	1
70	100127	NUT, mscr, hex	4
71	128648*	GUARD, spiral, 1/2 in, pe	1
73	121055*	CORD SET, us, mx, pr, ca, tw, 115 v, 10 a	1
76	128435	SWITCH, prox, m18, 10-30 vdc, no	2
77	127141	COLLAR, clamp, 1 in. id, 2 piece	2
79	15H108▲	LABEL, warning, pinch point	2
100	128441*	CABLE, gca, m12, 8-pin, m, 4m, pigtail	1
101	128197*◆	CABLE, gca, m12, 5-pin, fxm8, 4-pin, m	1
102	127949*◆	HARNESS, splitter, m12	1
103	125750*◆	CORD SET, euro/male, din/female, rev	2
104	102063	WASHER, lock, ext	4
105	195874	SCREW, mach, phil pan hd	2
108	15V551*	SHIELD, membrane, adm	1

--- Not available for individual sale.

* Not shown.

▲ Replacement Danger and Warning labels, tags, and cards are available at no cost.

❖ Includes 17C706 token.

◆ Parts are available in kit 25A106.

★ See Dosing Valve Instructions - Parts manual 313342 for parts/repair.

F4-5 Base/Ram - 24X281

- ⚠ Apply blue thread sealant to screws and torque to 30-35 ft-lb (41-47 N•m).
- 2. Apply pipe sealant to all non-swivel NPT threads, if needed.
- ⚠ Apply blue thread sealant and torque to 8-9 ft-lb (11-12 N•m).
- ⚠ Apply blue thread sealant.

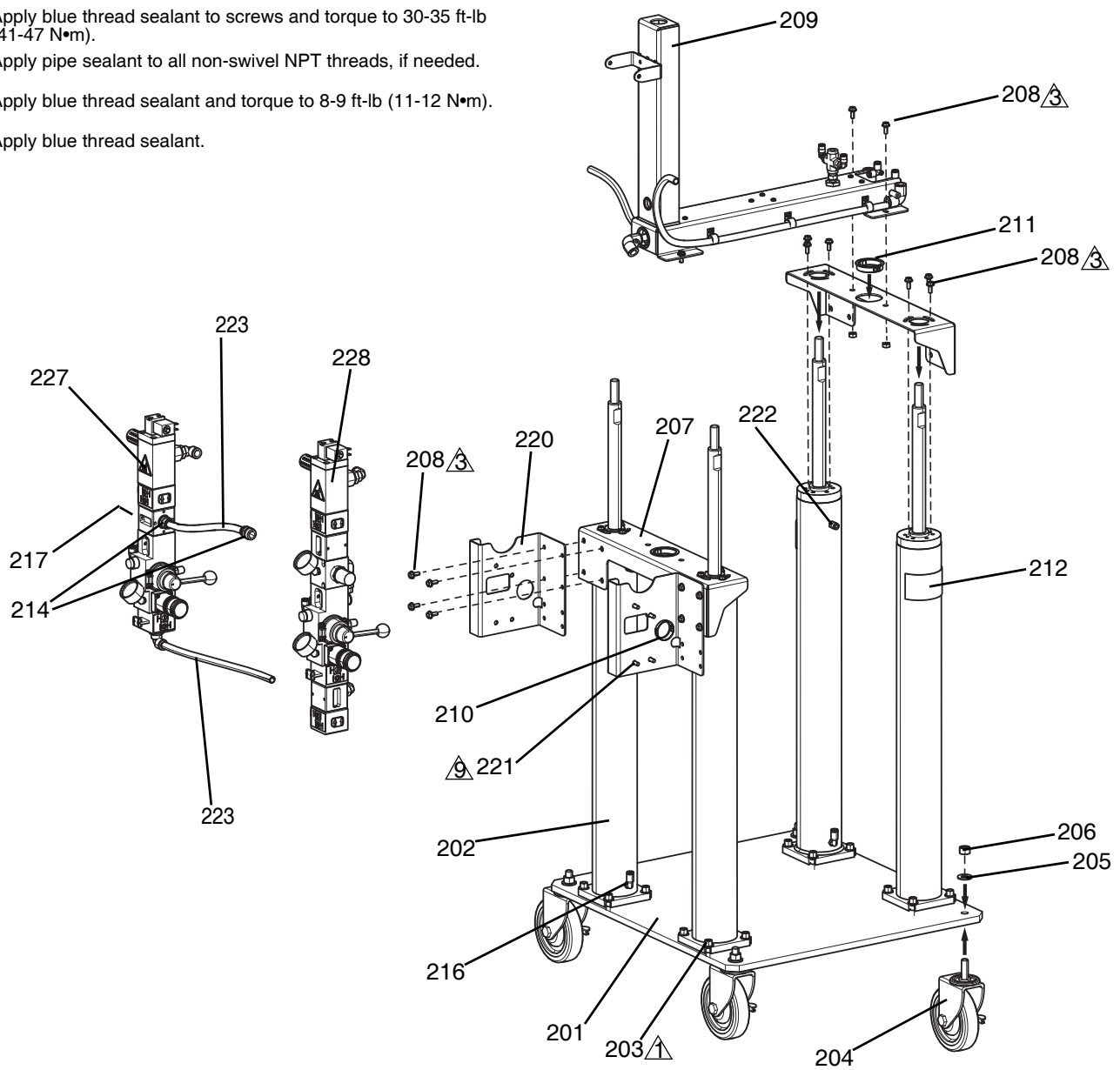
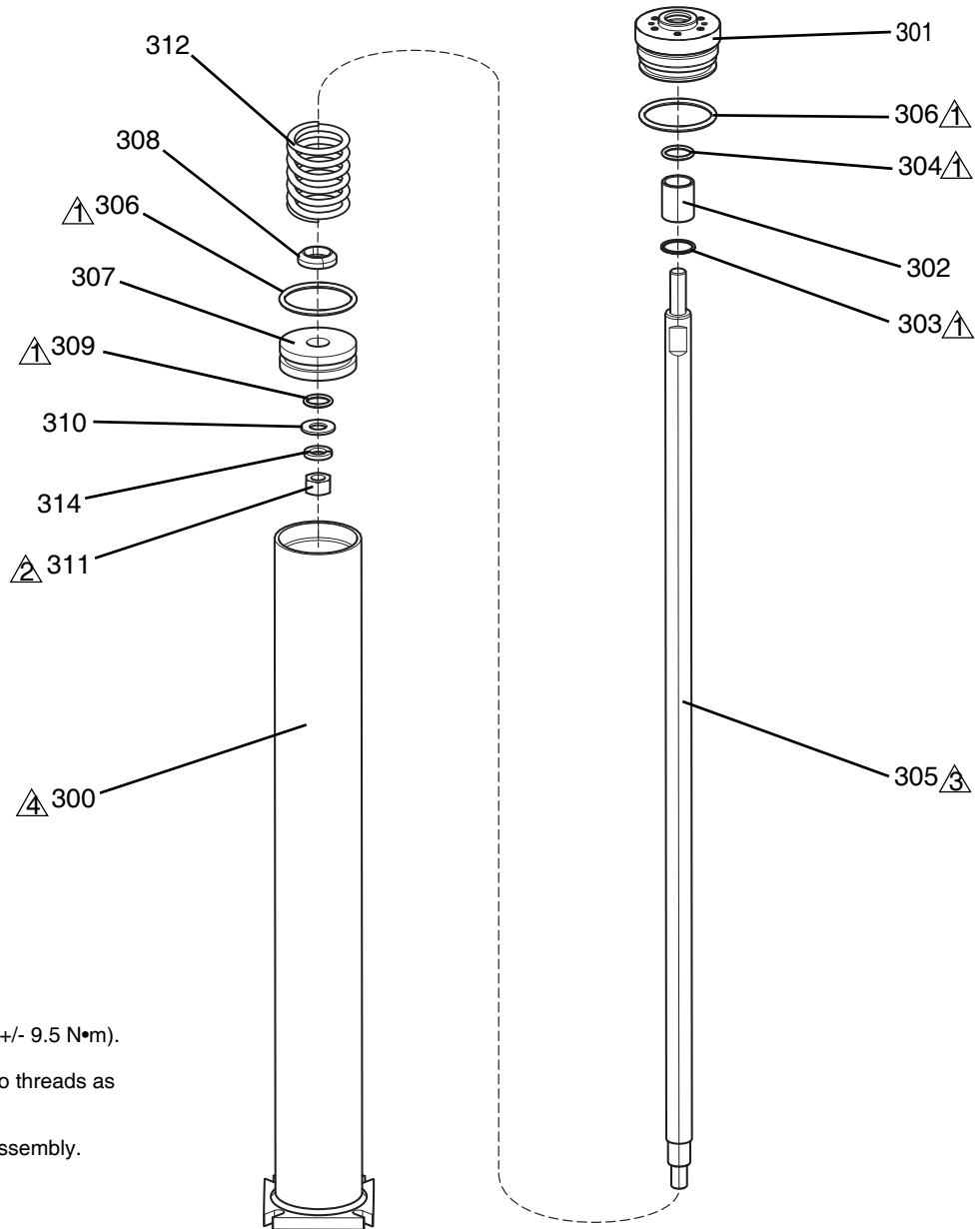

FIG. 3: F4-5 Base - Ram, Dual

Ref	Part	Description	Quantity
201	24W795	PLATE, base, ram,3.0", 5 gal, white	1
202	24W784	RAM, assy, air cylinder, 3.0 id	4
203	127048	SCREW, mach, hex, flange, m10 x 1.5 x 2	16
204	16M465	CASTER, locking	4
205	113962	WASHER, hardened, sae	4
206	100321	NUT	4
207	24W793	BRACKET, tiebar, ram, white	2
208	114182	SCREW, mach, hex flange	24
209	25A073	BRACKET, assembly, 5 gal	1
210	123589	BUSHING, wire protector, snap-in	1
211	124128	BUSHING, wire protector, snap-in	2
212	15J074▲	LABEL, safety, crush & pinch	2
214	114111	FITTING, connector, male	2
216	597151	FITTING, elbow	4
217	100361	PLUG, pipe	1
220	24W796	BRACKET, air tree, ram	2
221	121112	SCREW, cap, socket head	8
222	115671	FITTING, connector, male	4
223	61/2908-BK/11	TUBE, 0.320 id x 0.500 od, pu, 95 dur	2.5
227	24X286	CONTROL, air, 1/2", manifold	1
228	24X187	CONTROL, air, 1/2", reg, manifold	1

▲ Replacement Danger and Warning labels, tags, and cards are available at no cost.

F4-5 Ram Air Cylinder - 24W784



- ⚠️ 1 Apply lubricant to o-rings.
- ⚠️ 2 Torque to 30 +/- 7 ft-lb (41 +/- 9.5 N•m).
- ⚠️ 3 Apply blue thread sealant to threads as needed.
- ⚠️ 4 Lightly oil cylinder before assembly.

FIG. 4: F4-5 Ram Air Cylinder

Ref	Part	Description	Quantity
300	24W786	TUBE, ram, assy, 3.0 id, white	1
301	16V079	CAP, bearing, air cylinder	1
302	16V080❖	BEARING, air cylinder	1
303	127022❖	RING, retaining, spiral	1
304	160516❖	PACKING, o-ring, 214	1
305	17C803	ROD, piston, ram	1
306	160258❖	PACKING, o-ring, buna-n	2
307	183943	PISTON,	1
308	16V081	GUIDE, spring	1
309	156401❖	PACKING, o-ring	1
310	111841	WASHER, plain 5/8	1
311	100127	NUT, mscr, hex	1
312	160138	SPRING, compression	1
314	100128	WASHER, lock	1
315	16M106 ❖*	LUBRICANT, o-rings	1

❖ *Parts are available in kit 25A197.*

* *Not shown.*

Air-Line Bracket Assembly - 25A073

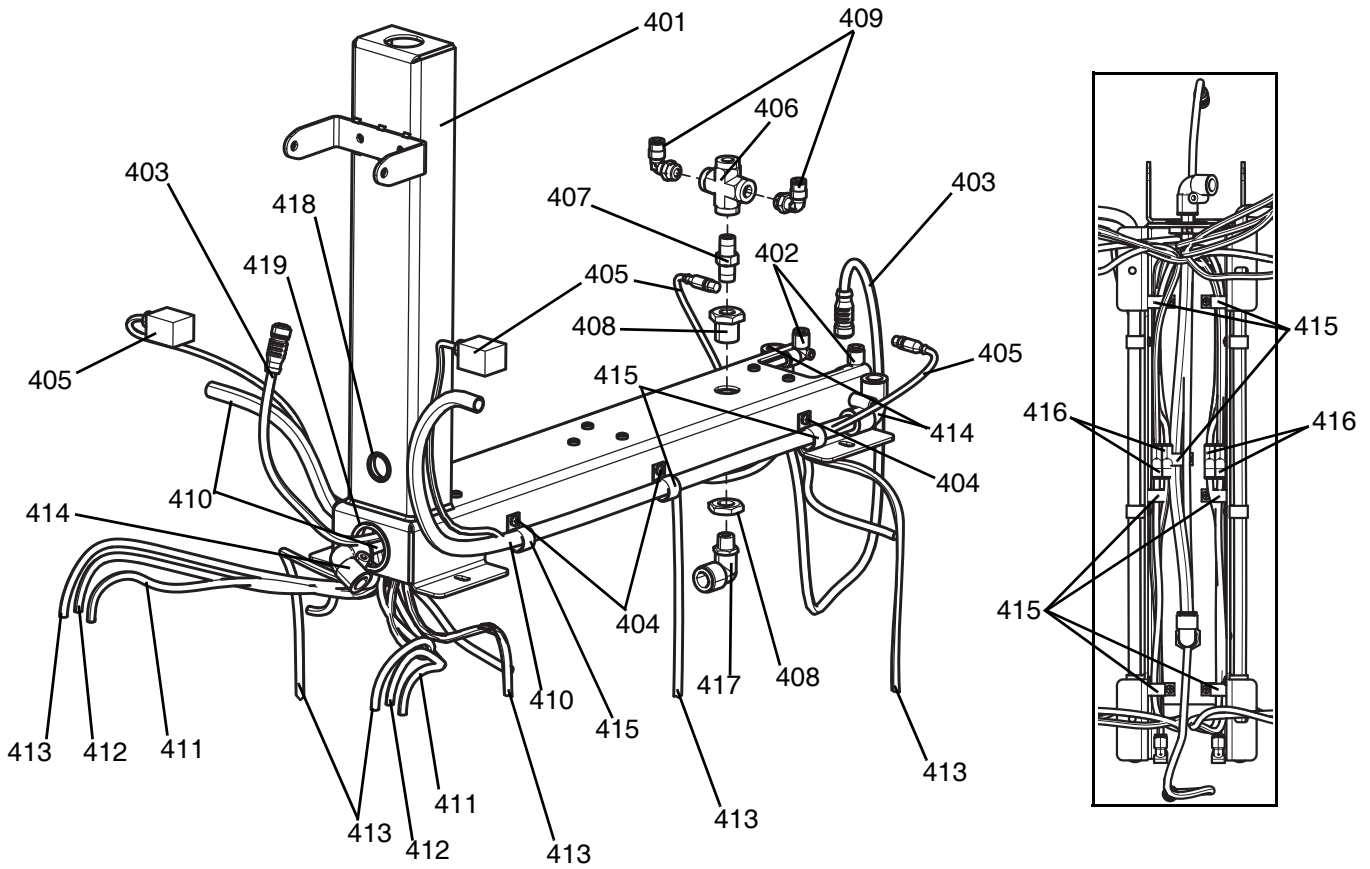

4. Apply pipe sealant as needed.

FIG. 5: Air-Line Bracket

Ref	Part	Description	Quantity
401	---	BRACKET, support, ram, 3.0", 5 gal, wht	1
402	C20354	FITTING, elbow, union, qd	2
403	121002	CABLE, can, female / female 1.5m	1
404	96/0651/99	FASTENER, bhcs, 10-32 x 0.38, ms, e	13
405	15Y047	CABLE, m8-din i	2
406	94/0502/96	FITTING, cross, 1/4 npt, f, brs	1
407	94/0507/96	FITTING, nipple, hex, 1/4 npt, brs	1
408	94/0508/96	FITTING, bulkhead, 1/4 npt, f, brs	1
409	121022	FITTING, elbow, male, 1/4 npt	2
410	61/2908-BK/11	TUBE, 0.320 id x 0.500 od, pu, 95 dur,	6.5
411	61/2904-BU/11	TUBE, 0.160 id x 0.250 od, pu, 95 dur,	10
412	61/2904-RD/11	TUBE, 0.160 id x 0.250 od, pu, 95 dur,	6.5
413	61/2904-BK/11	HOSE, .160 id x .250 od, pu, 95 dur	15.9 ft.
414	128262	FITTING, elbow ,90, 1/2" tube, fxf	3
415	84/0153/89	CLAMP, wire, harness, 5/8, nyl	13
416	115287	FITTING, y tube	4
417	121459	FITTING, elbow, 90, 1/2" tube x 1/4 nptm	1
418	124232	BUSHING, wire protector, .875 dia	1
419	123589	BUSHING, wire protector, snap-in	1

--- Not available for individual sale.

F4-5 Platen - 25A206

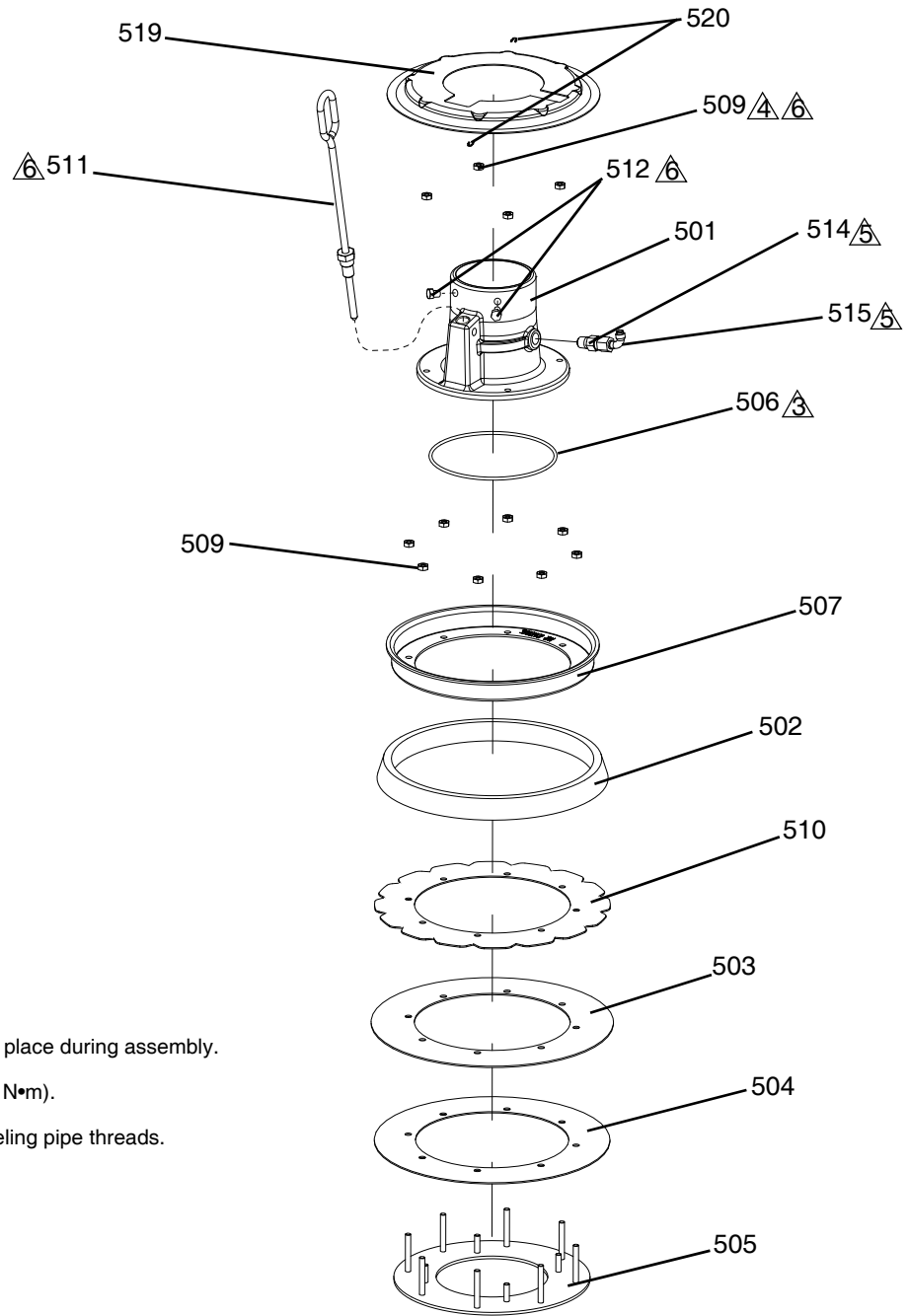

- △3 Apply lubricant to hold ring in place during assembly.
- △4 Torque to 45 +/- in-lb (5 +/- .6 N•m).
- △5 Apply sealant to all non-swiveling pipe threads.
- △6 Add lubricant to threads.

FIG. 6: F4-5 Platen

Ref	Part	Description	Quantity
501	---	BASE, platen, sst, 20-60 l	1
502	276049❖	SPACER	1
503	25A208❖	WIPER, main, nbr, fda approved	1
504	257681❖	WIPER, pe support	1
505	---❖	PLATE, bottom, platen	1
506	121829	O-RING, packing -162	1
507	---❖	CLAMP, 20 liter, retaining	1
509	109478❖	NUT, lock, hex, sst	12
510	257689	WIPER, support	1
511	257697	HANDLE, bleed, sst, assy	1
512	112894	SCREW, cap, hex hd	2
514	501867	VALVE, check 1/4 npt, ss	1
515	C20350	FITTING, elbow 90 deg	1
519	15W184❖	COVER, 20 l, shroud	1
520	16U740❖	PIN, hairpin, cotter	2

-- Not available for individual sale.

❖ Parts are available in kit 25A207.

F4-55 Base Models

F4-55 System - 24X167 and 24X169

NOTE: F4-55 models are offered with or without casters installed. Part 24X167 includes casters. Part number 24X169 does not include casters. There is an optional caster kit (part no. 24X218) available for attaching casters to 24X169. See the Fluid Automation F4 Series Kits-Accessories manual 3A3103 for information about the caster kit.

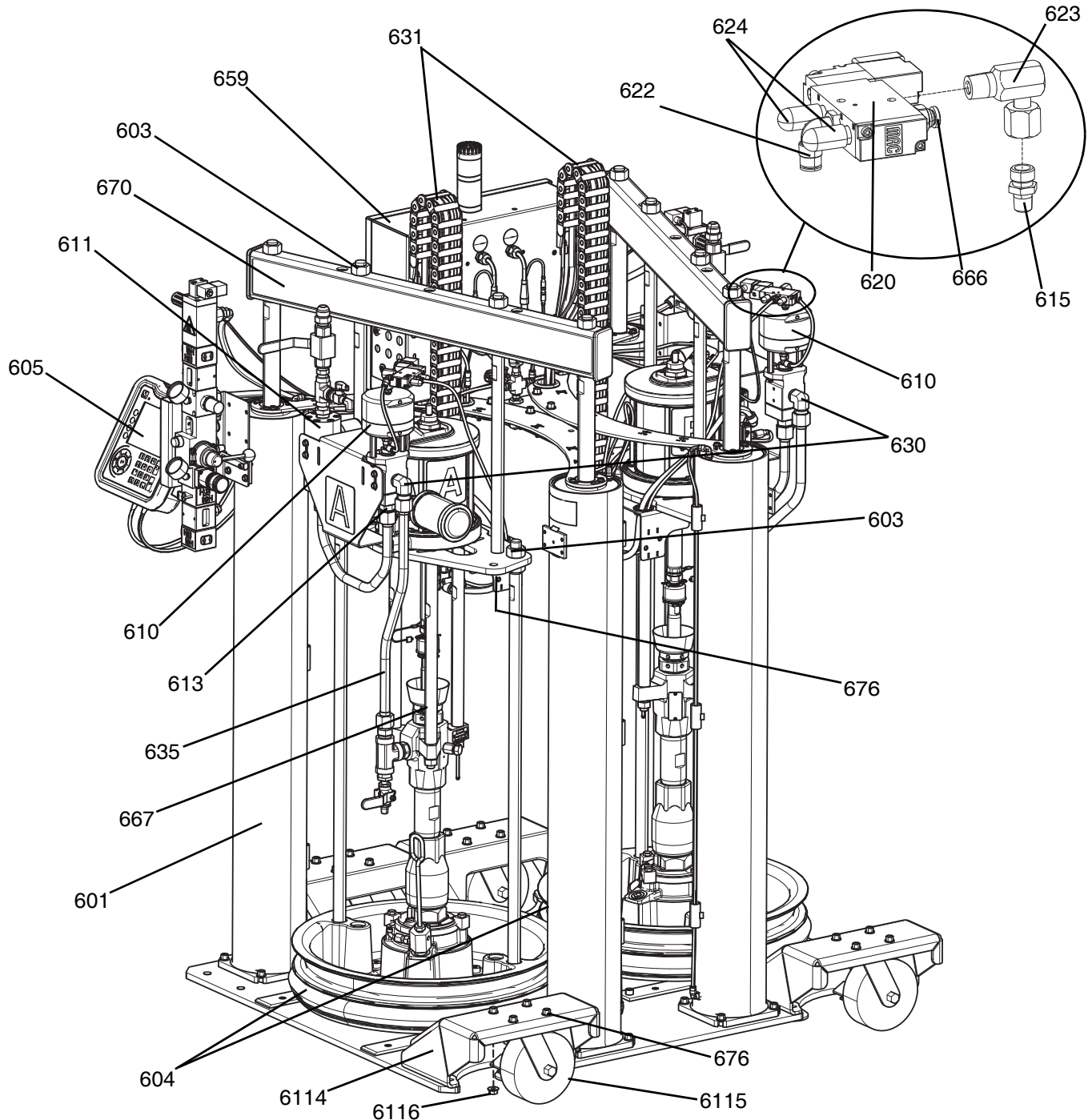

FIG. 7: F4-55 Model, 24X167 with Casters - View 1

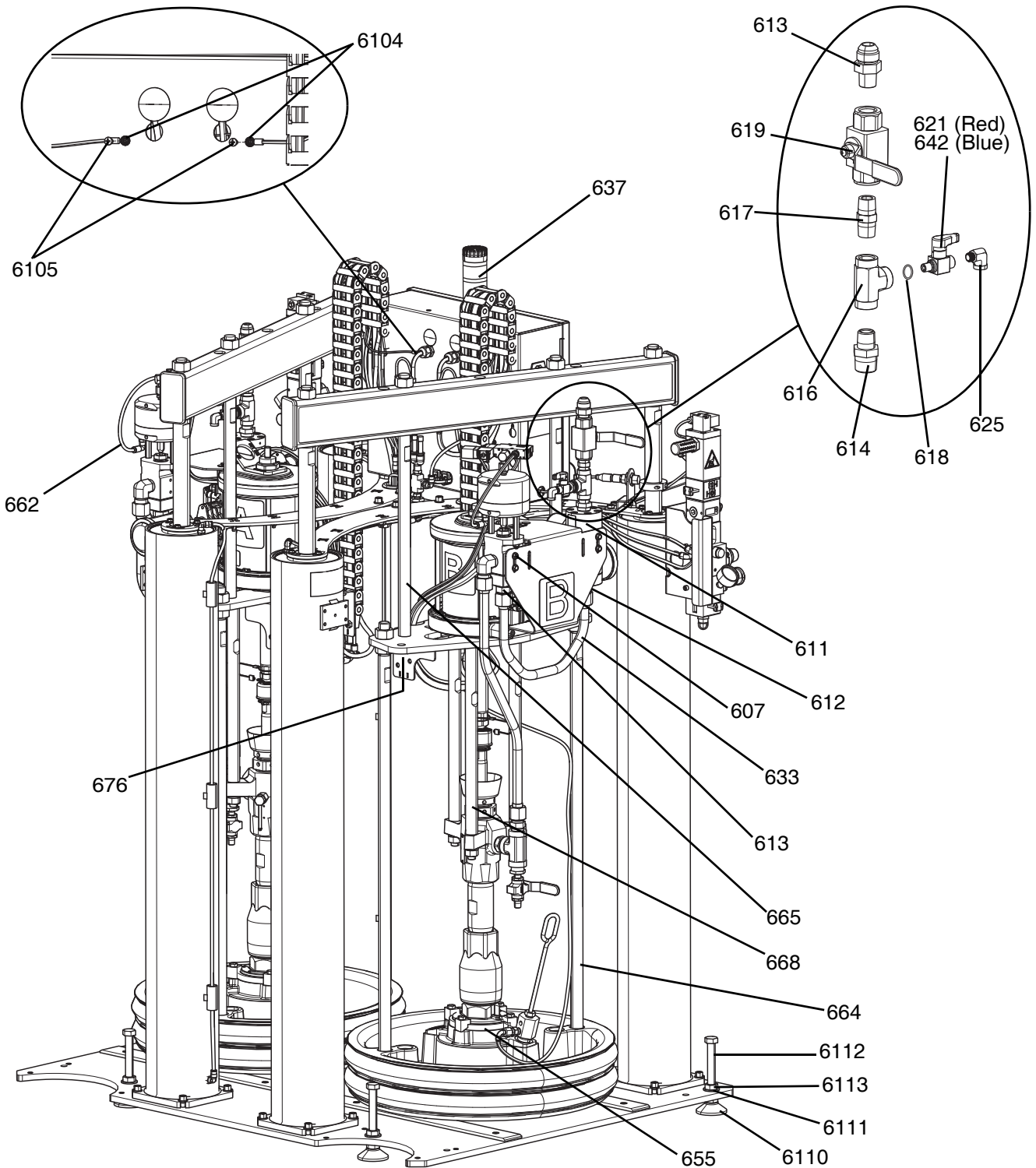

FIG. 8: F4-55 Model, 24X169 without Casters - View 2

NOTE: Part 24X169 has levelers instead of casters. Part 24X167 does not have levelers.

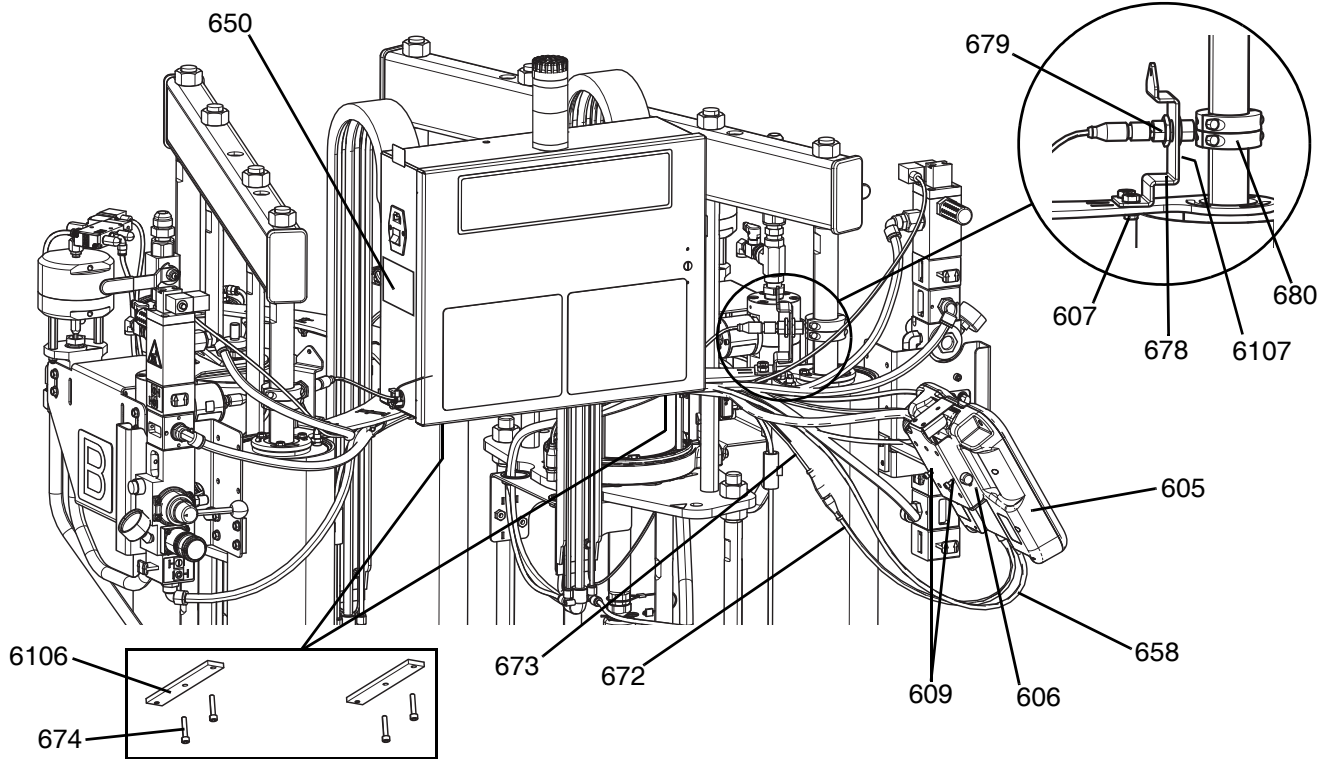

FIG. 9: F4-55 Model - View 3

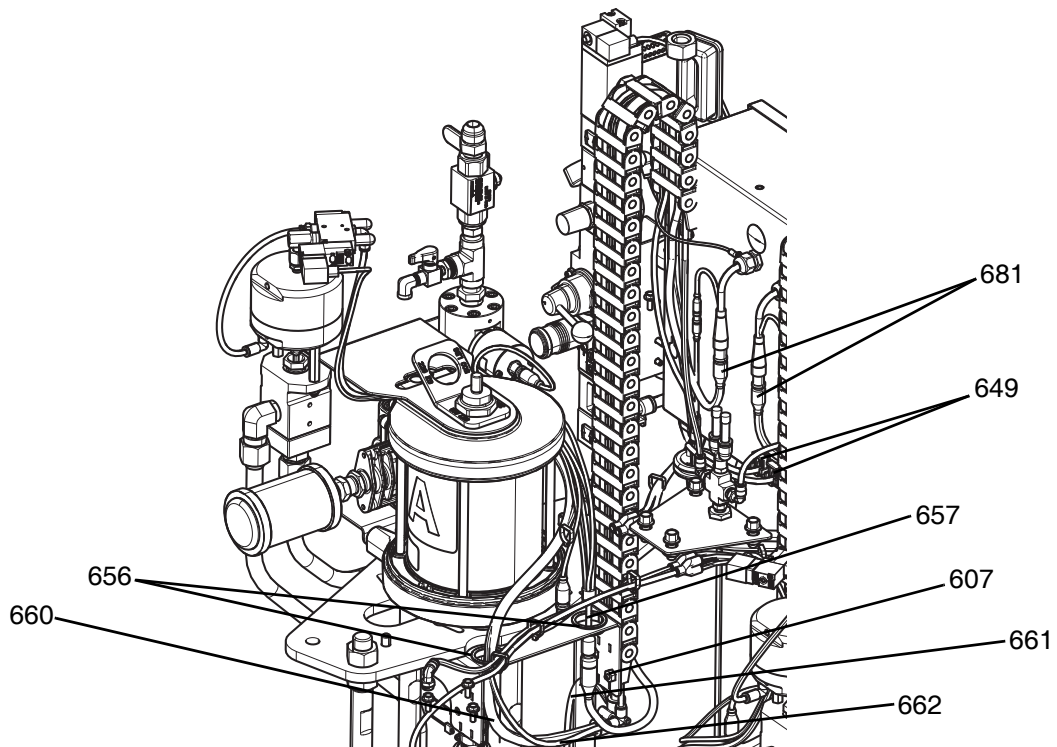

FIG. 10: F4-55 Model - View 4

NOTE: This parts list also applies to Model F4-55-5. See page 22.

Ref	Part	Description	Quantity
601	---	RAM, dual, 55 gal	1
603	101535	NUT, full hex	12
604	25A230	PLATE, wiper, 55 g, neo, no sulphur	2
605	25A171❖	KIT, adm lsr f4	1
606	255235	BRACKET, mounting, assembly	1
607	114182	SCREW, mach, hex flange	20
609	120885	SCREW	2
610	24W994	VALVE, assy, ratio control, ss	2
611	246652	METER, heli gear, hi resolution	2
612	15M863	FITTING, connector, male	2
613	94/1027/98	ADAPTER, jic 12 x 1/2 npt, mm, ss, 3k, 316	4
614	16R883	FITTING, nipple, reducing, 3/4 x 1/2	2
615	191872	FITTING, adapter	2
616	128309	FITTING, tee, 1/2 npt	2
617	114373	FITTING, nipple, 1/2 npt, sst hex	2
618	128055	FITTING, bushing, 1/2 npt x 1/8 npt, ss	2
619	262739	VALVE, 1/2 in. ball	2
620	127356	VALVE, power, 5/2, 24 vdc	2
621	256459	KIT, a side valve	1
622	121022	FITTING, elbow, male, 1/4 npt	2
623	155541	FITTING, swivel, 90 degree	2
624	512909	MUFFLER, polyethylene	4
625	128054	FITTING, elbow, st, 90, 1/8 npt, ss	2
630	94/1035/98	ADAPTER, elbow, 90, jic 12 x 1/2 npt, mm	2
631	24X638	GUIDE, cable, hose	2
633	17D355	TUBE, valve, xm, flow meter	2
635	17D354	TUBE, valve, xm, outlet	2
637	127187	LIGHT, tower, 30 mm, red/grn/alarm	1
642	256460	KIT, b side valve	1
649	124005	BUSHING, strain relief	3
650	---	BLANK, label, kit, 3 x 3	1
655	255392	KIT, mounting, cm lower	2
656	123679	BUSHING, wire protector, 1 3/8 od	4
657	25A036	CABLE, gca, sig, assy, pump	2
658	121002	CABLE, can, female / female 1.5 m	1
659	---	MODULE, controls	1
660	61/2908-BK/11	TUBE, 0.320 id x 0.500 od, pu, 95 dur	6
661	61/2904-RD/11	TUBE, 0.160 id x 0.250 od, pu, 95 dur	8
662	61/2904-BK/11	HOSE, .160 id x .250 od, pu, 95 dur	5
664	17E141	ROD, tie, platen, lower, 55	4
665	17E142	ROD, tie, platen, upper, 55/5	4
666	94/0701/96	CONNECTOR, 1/4 tube x 1/4 npt, m, brs	2

F4-55 Base Models

667	25A092	PUMP, assembly, 40:1, a side	1
668	25A093	PUMP, assembly, 40:1, b side	1
670	17D088	LABEL, identification	2
671	124662*	GUARD, spiral, 1/2 in., pe	1
672	128308	CABLE, gca, m 12 x m 12, 4-pin x 4-pin	1
673	123673	HARNESS	1
674	126797	SCREW, socket head, m6 x 25 mm	4
676	127048✓	SCREW, mach, hex, flange, m10 x 1.5 x 2	4
	127048✘	SCREW, mach, hex, flange, m10 x 1.5 x 2	36
678	24X601	BRACKET, sensor, assy, white	2
679	128435	SWITCH, prox, m18, 10-30 vdc, no	2
680	127140	COLLAR, clamp, 1-3/8 id, 2-piece	2
681	15Y047	CABLE, m8-din i	2
682	121055*	CORD SET, us, mx, pr, ca, tw, 115 v, 10 a	1
683	17C706*	SOFTWARE, gca, lsr	1
6100	128441*◆	CABLE, GCA, m12, 8-pin, m, 4m, pigtail	1
6101	128197*◆	CABLE, GCA, m12, 5-pin, fxm8, 4-pin, m	1
6102	127949*◆	HARNESS, splitter, m12	1
6103	125750*◆	CORD SET, euro/male, din/female, rev	2
6104	102063	WASHER, lock, ext	4
6105	195874	SCREW, mach, phil pan hd	2
6106	25A159	BRACKET, support	2
6107	15H108▲	LABEL, warning pinch point	4
6110	126848✓	LEVELER, foot, 5/8-11, 2.5 in. dia 6 L	5
6111	111841✓	WASHER, plain, 5/8	5
6112	126849✓	BOLT, tap, hex, 5/8-11 x 5 in., A307, CS	5
6113	100127✓	NUT, mscr, hex	5
6114	24X217✘	BRACKET, caster, white	4
6115	121495✘	CASTER, swivel, w/brake, 800 lbs	4
6116	127076✘	NUT, hex, flange, serrated, m 10	16

--- Not available for individual sale.

* Not shown.

❖ Includes 17C706 software token.

◆ Parts are available in kit 25A106.

▲ Replacement Danger and Warning labels, tags, and cards are available at no cost.

✓ Parts are for 24X168 (F4-55-5) and 24X169 (F4-55) with levelers only.

✘ Parts are for 24X166 (F4-55-5) and 24X167 (F4-55) with casters only.

F4-55 Platen - 25A230

2. Use thread tape on all non-swivel pipe threads.

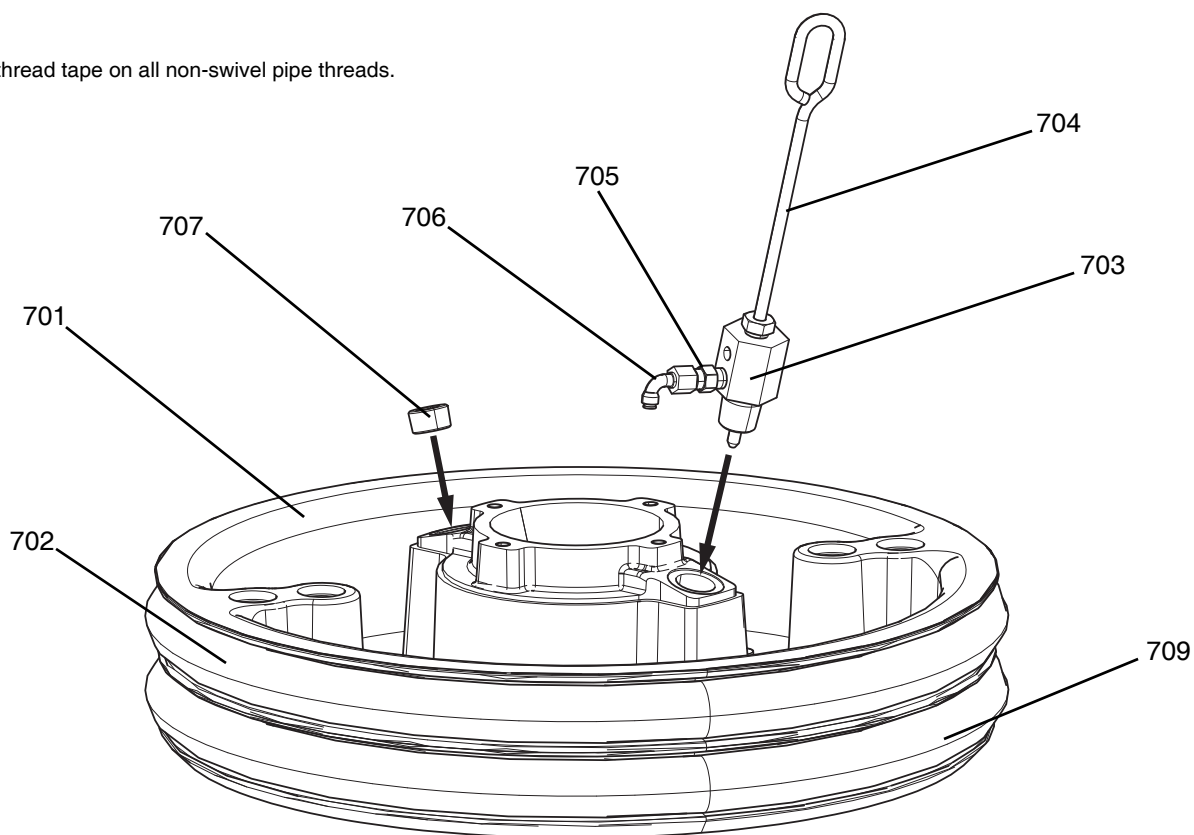

FIG. 11: F4-55 Platen

Ref	Part	Description	Quantity
701	15Y351	PLATE, ram, 55 gal, low volume, htd	1
702	---❖	SEAL, drum wiper 55 gal neoprene	1
703	16W974	ADAPTER, bleed stick, sst	1
704	257697	HANDLE, bleed, sst, assy	1
705	501867	VALVE, check	1
706	C20350	FITTING, elbow 90 deg	1
707	111384	PLUG, pipe	1
709	---❖	SEAL, drum wiper 55 gallon, neo	1

--- Not available for individual sale.

❖ Parts are available in kit 25A116.

F4-55-5 System - 24X166 and 24X168

NOTE: F4-55-5 models are offered with or without casters installed. Part 24X166 includes casters. Part number 24X168 does not include casters, but has levelers instead. There is an optional caster kit (part no. 24X218) available for attaching casters to 24X168. See the Fluid Automation F4 Series Kits-Accessories manual 3A3103 for information about the caster kit.

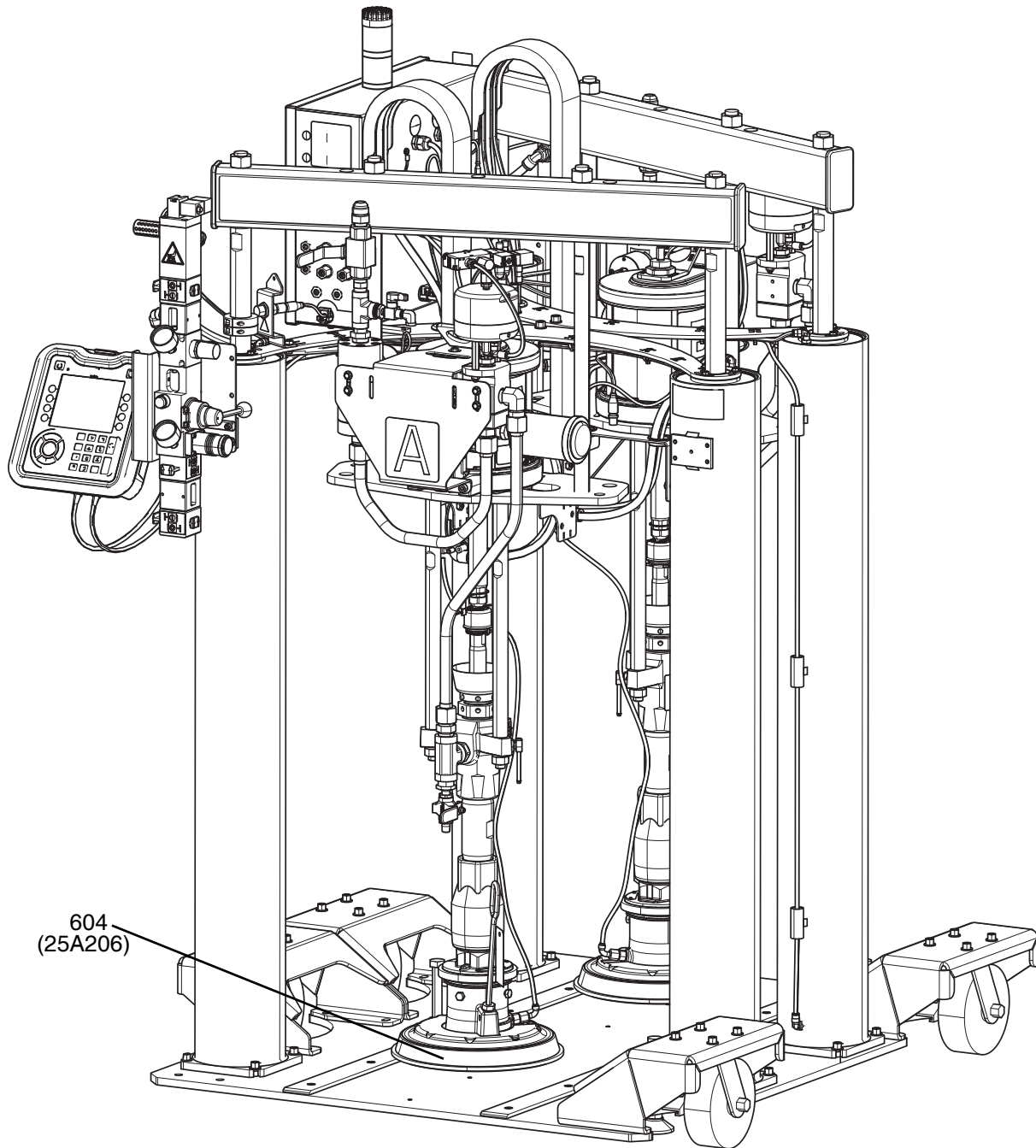

Fig. 12: F4-55-5 Model, 24X166 with Casters

F4-55-5 Model

Refer to the F4-55 parts list on page 19 and Figures 7-10 to identify the F4-55-5 parts. There are only three differences in the parts list between the F4-55 and the F4-55-5.

On the F4-55-5:

- The platen (Ref. 604 on the F4-55 parts list) is part no. 25A206 on the F4-55-5. See page 14 for a description of the parts for this 5 gallon platen.
- Part no. 255392 (Ref. 655) is not required for the 5 gallon model and is not included on the F4-55-5.
- Part no. 17E141 (Ref. 664) is not required for the 5 gallon model and is not included on the F4-55-5.

F4-55 and 55-5 Base/Ram - 24X185

1. Apply sealant to all non-swivel npt threads if the fitting does not already have a sealant applied.

 Apply adhesive and torque fasteners in this order.

 Torque to 30-35 ft-lb (41-47 N•m).

 Torque to 8-9 ft-lb (11-12 N•m).

 Torque to 30-35 ft-lb (41-47 N•m)

 Torque to 0-35 ft-lb (41-47 N•m)

 Apply adhesive and torque to 30-35 ft-lb (41-47 N•m).

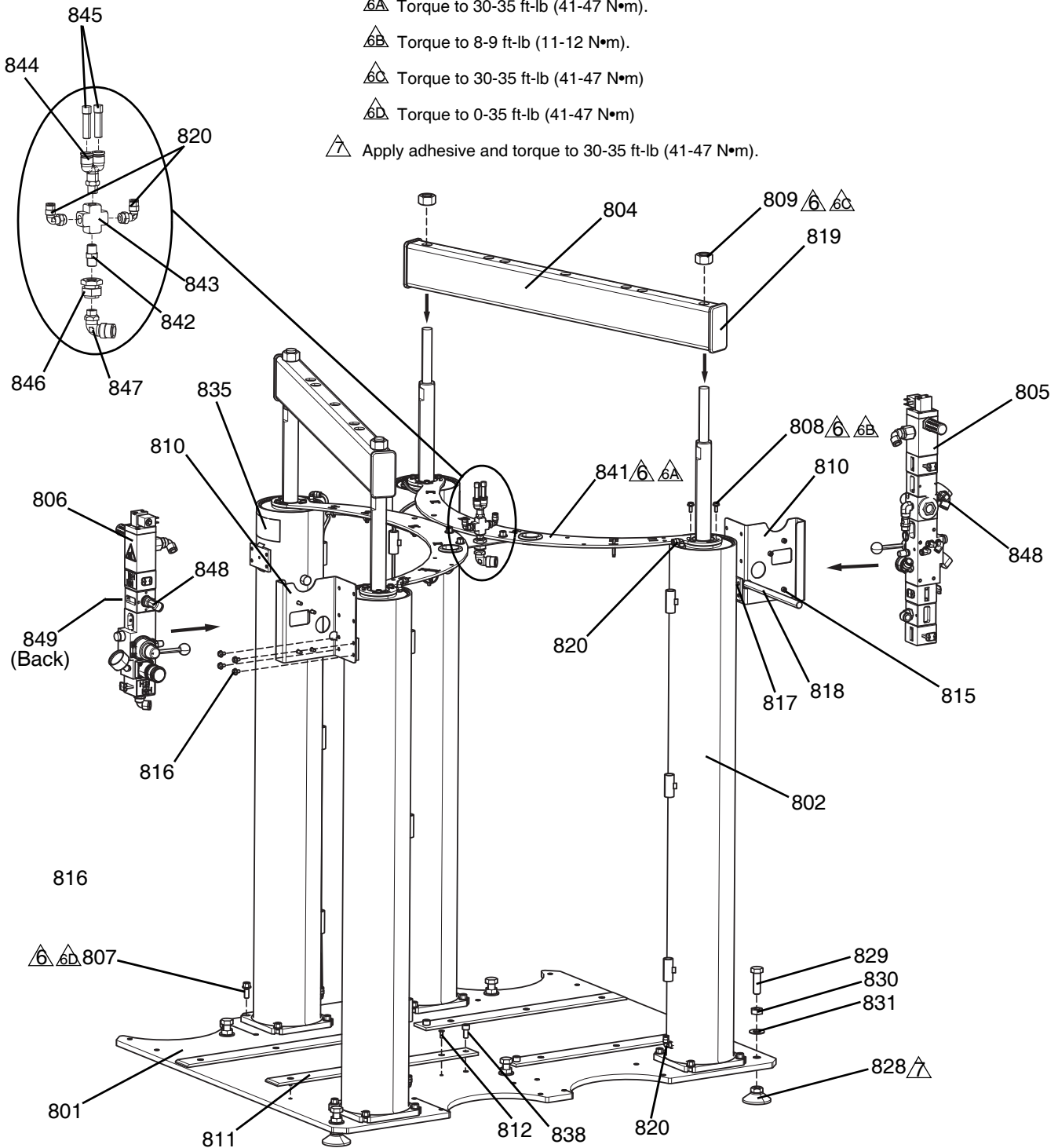
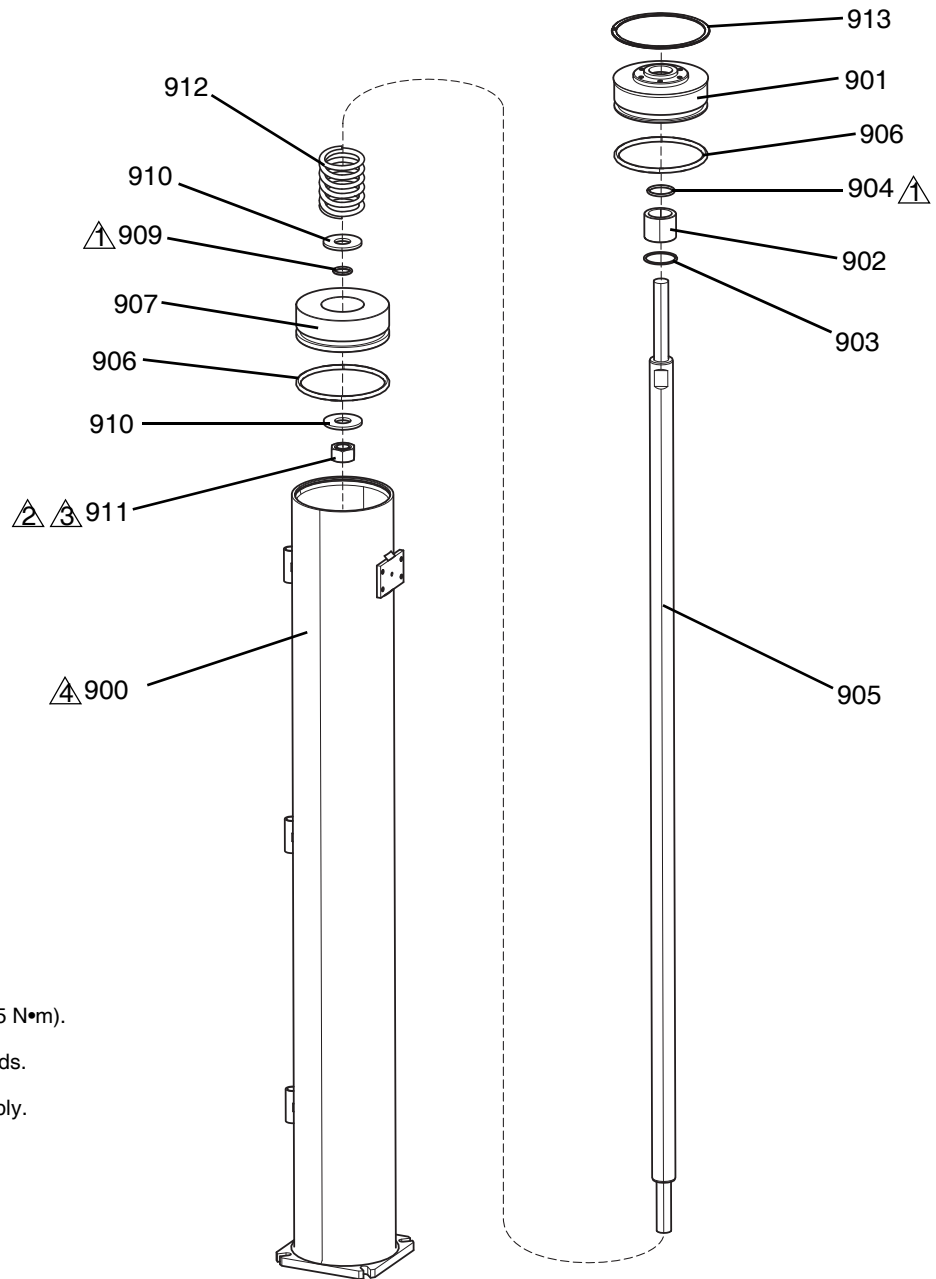

FIG. 13: F4-55 Base - Ram, Dual

Ref	Part	Description	Quantity
801	24X178	BASE, plate, ram, dual 55 gal, white	1
802	24X176	RAM, assy, air cylinder, 5.5 id	4
804	24X188	BEAM, tie, ram, white	2
805	24X187	CONTROL, air, 1/2", reg, manifold	1
806	24X286	CONTROL, air, 1/2", manifold	1
807	127048	SCREW, mach, hex, flange, m10 x 1.5 x 2	16
808	114182	SCREW, mach, hex flange	12
809	101535	NUT, full hex	4
810	24W796	BRACKET, air tree, ram	2
811	16V208	GUIDE, drum, umhw	4
812	127036	SCREW, mach, flatd, socket, m6 x 16	12
815	121112	SCREW, cap, socket head	8
816	127047	SCREW, mach, hex, flange, m6 x1 x 10 mm	6
817	126797	SCREW, socket head, m6 x 25 mm	2
818	16V527	BAR, bracket, ram, dm	1
819	189559	CAP, end	4
820	121022	FITTING, elbow, male, 1/4 npt	10
828	126848	LEVELER, foot, 5/8-11, 2.5" dia, 6k	5
829	126849	BOLT, tap, hex, 5/8-11 x 5", a307, cs	5
830	100127	NUT, mscr, hex	5
831	111841	WASHER, plain 5/8	5
835	15J074▲	LABEL, safety, crush & pinch	2
838	127037	SCREW, cap, socket head, m10 x 20	4
841	25A069	BRACKET, assembly, air lines, 55 gal	1
842	123257	FITTING, nipple, hex, 1/4npt, brs	1
843	113264	CROSS, pipe	1
844	128052	FITTING, wye, 1/4 npt x 3/8 tube	1
845	124419	PLUG, tube, push, 3/8"	2
846	94/0508/96	FITTING, bulkhead, 1/4 npt, f, brs	1
847	121459	FITTING, elbow, 90, 1/2 in. tube x 1/4 nptm	1
848	15V204	FITTING, elbow, 1/2 npt x 1/2 tube	2
849	100361	PLUG, pipe	1

▲ Replacement Danger and Warning labels, tags, and cards are available at no cost.

F4-55 and 55-5 Ram Air Cylinder - 24X175



- ① Apply lubricant to o-rings.
- ② Torque to 30 +/- 7 ft-lb (41 +/- 9.5 N•m).
- ③ Apply blue thread locker to threads.
- ④ Lightly oil cylinder before assembly.

FIG. 14: F4-55 Ram Air Cylinder

Ref	Part	Description	Quantity
900	24X174	RAM,TUBE,ASSY,5.5 ID,WHITE	1
901	17C775	CAP,AIR CYLINDER,5.5 ID	1
902	---❖	BEARING,RAM END CAP	1
903	15F453❖	RETAINER,RETAINING RING 1.88 BORE	1
904	---❖	PACKING,O-RING	1
905	167651	ROD,PISTON RAM	1
906	---❖	O-RING	2
907	17C774	PISTON,AIR CYLINDER,5.5 ID	1
909	---❖	PACKING,O-RING	1
910	128057	WASHER,FLAT,7/8,USS,CS,ZINC PLT	2
911	101535	NUT,FULL HEX	1
912	160138	SPRING,COMPRESSION	1
913	128041	RING,RETAINING,ID,5.625	1
914	16M106*	LUBRICANT	1

--- *Not available for individual sale.*

❖ *Parts are available in kit 25A198.*

* *Not shown.*

F4-55 and 55-5 Air Line Bracket Assembly - 25A069

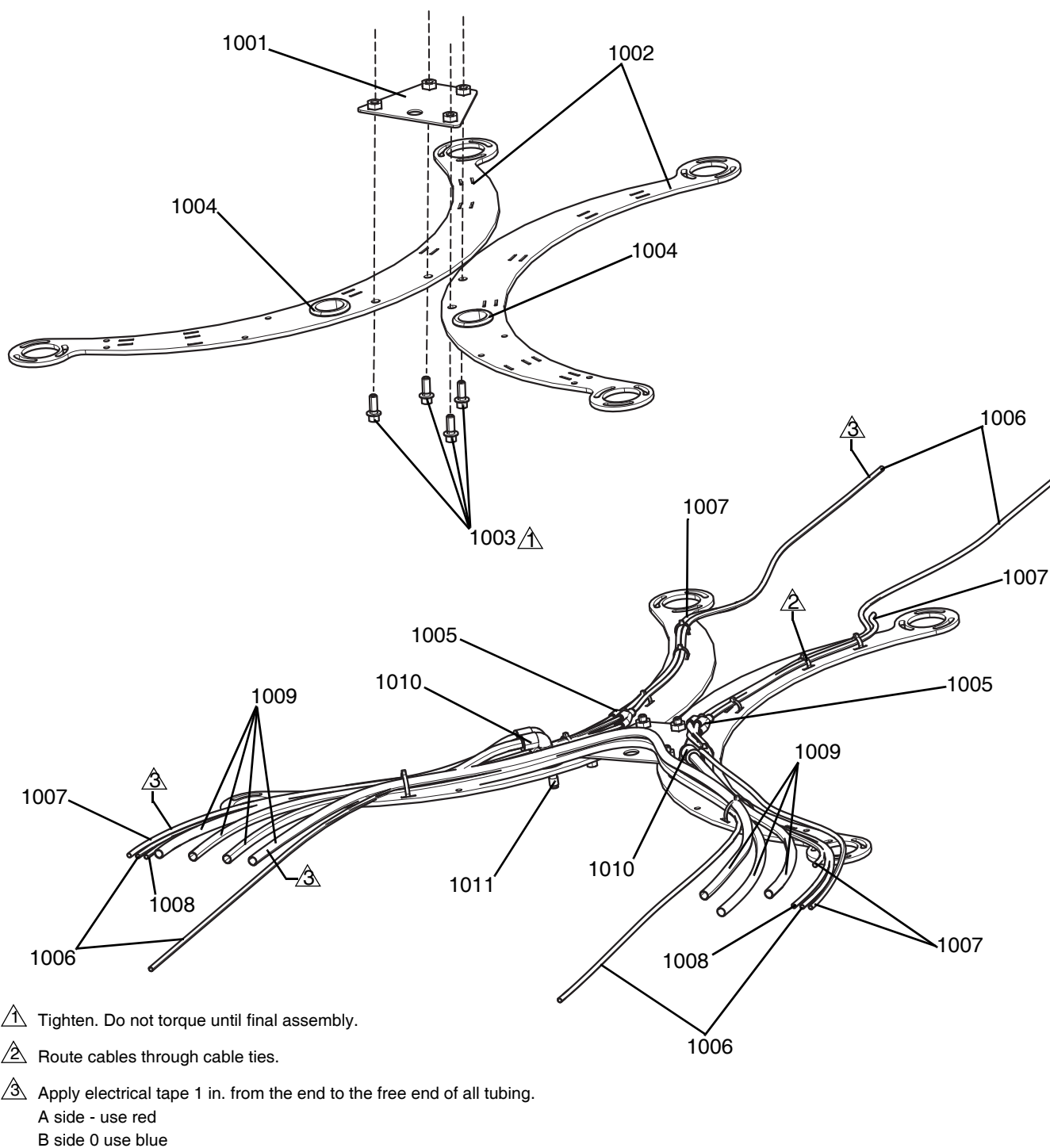
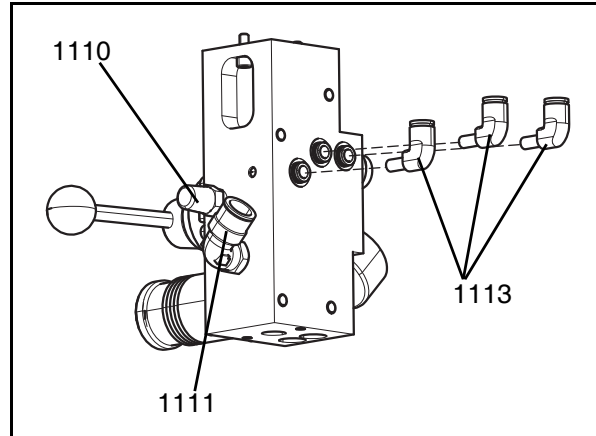
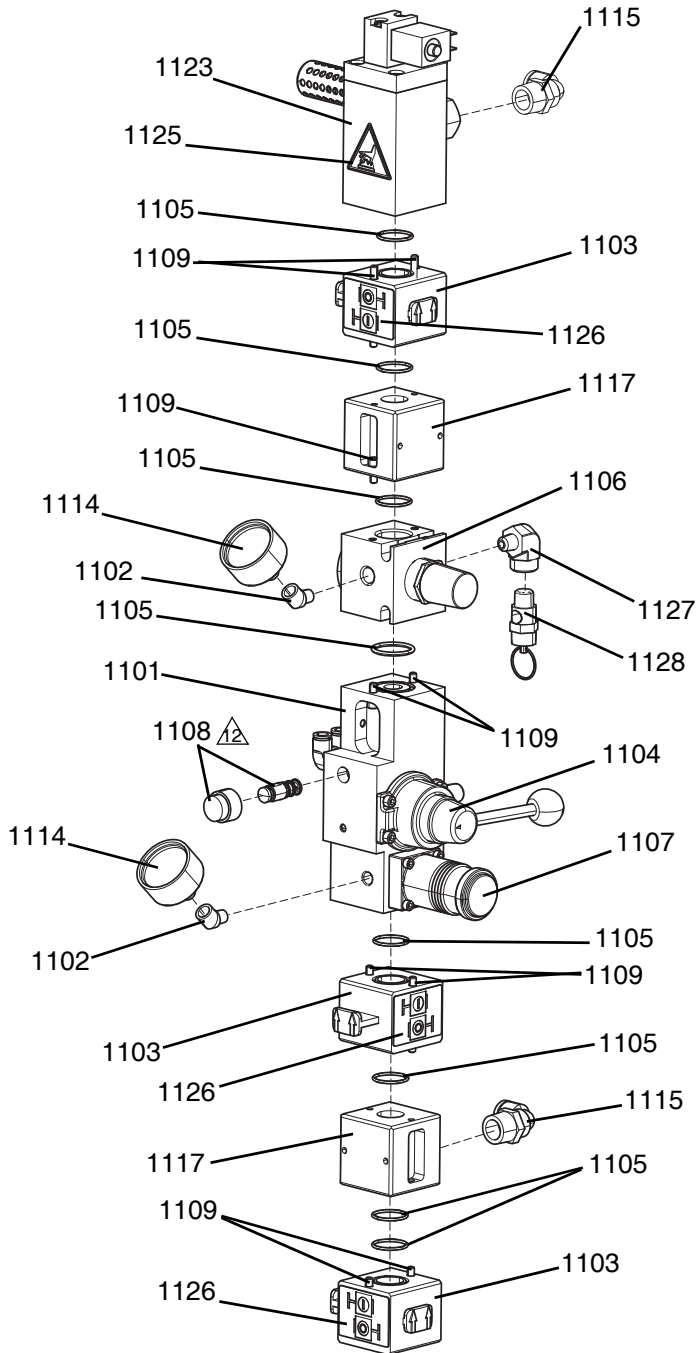

FIG. 15: Air Line Bracket Assembly

Ref	Part	Description	Quantity
1001	24X196	PLATE, joining, assy, white	1
1002	24X177	SUPPORT, ram, large, white	2
1003	127048	SCREW, mach, hex, flange, m 10 x 1.5 x 2	4
1004	128214	GROMMET, rubber, 1.5 id, 1.75 od, .25 tk	2
1005	115287	FITTING, y tube	4
1006	61/2904-BK/11	HOSE, .160 id x .250 od, pu, 95 dur	27.4 ft
1007	61/2904-BU/11	TUBE, 0.160 id x 0.250 od, pu, 95 dur,	13.1 ft
1008	61/2904-RD/11	TUBE, 0.160 id x 0.250 od, pu, 95 dur,	2.2 ft
1009	61/2908-BK/11	TUBE, 0.320 id x 0.500 od, pu, 95 dur,	18.6 ft
1010	128262	FITTING, elbow, 90, 1/2 in. tube, fxf	2
1011	123789	COUPLER, 1/4 in. od tubing	2

Common Parts

Main Integrated Air Control - 24X187



5. Apply sealant to all threaded fasteners.
 6. Apply sealant to all assembled pipe threads.
 7. Apply lubricant to all o-rings.
-  Apply sealant to the threads of the control valve handle and the threads of the valve.

FIG. 16: Main Integrated Air Control

Ref	Part	Description	Quantity
1101	---	MANIFOLD, ram, air, 1/2	1
1102	113630	ELBOW, street 45 degree 1/8 npt	2
1103	121793	VALVE, shut-off, modular, 1/2 npt	3
1104	121107	VALVE, control	1
1105	102620	PACKING, o-ring	8
1106	257614	REGULATOR, modular, 1/2 npt	1
1107	121106	REGULATOR, manifold mounting	1
1108	121109	VALVE, blow-off	1
1109	120039	FASTENER, shcs, 10-32 x .5	16
1110	517449	MUFFLER, sintered, 1/4 npt	1
1111	114128	FITTING, elbow, male, swivel	1
1113	113318	FITTING, elbow, plug in	3
1114	113911	GAUGE, pressure, air	2
1115	15V204	FITTING, elbow, 1/2 npt x 1/2 tube	2
1117	17D478	BLOCK, supply, air, 1/2 in.	2
1123	121948	SOLENOID, air motor, small	1
1125	189285▲	LABEL, caution	1
1126	15V954	LABEL, valve, shutoff, air control	2
1127	121150	FITTING, elbow, 1/4 fnpt x 1/8 mnpt	1
1128	116643	VALVE, safety, relief, air	1

--- Not available for individual sale.

▲ Replacement Danger and Warning labels, tags, and cards are available at no cost.

Refer to Air Controls Instructions - Parts manual 312374 for more information.

Secondary Integrated Air Control - 24X286

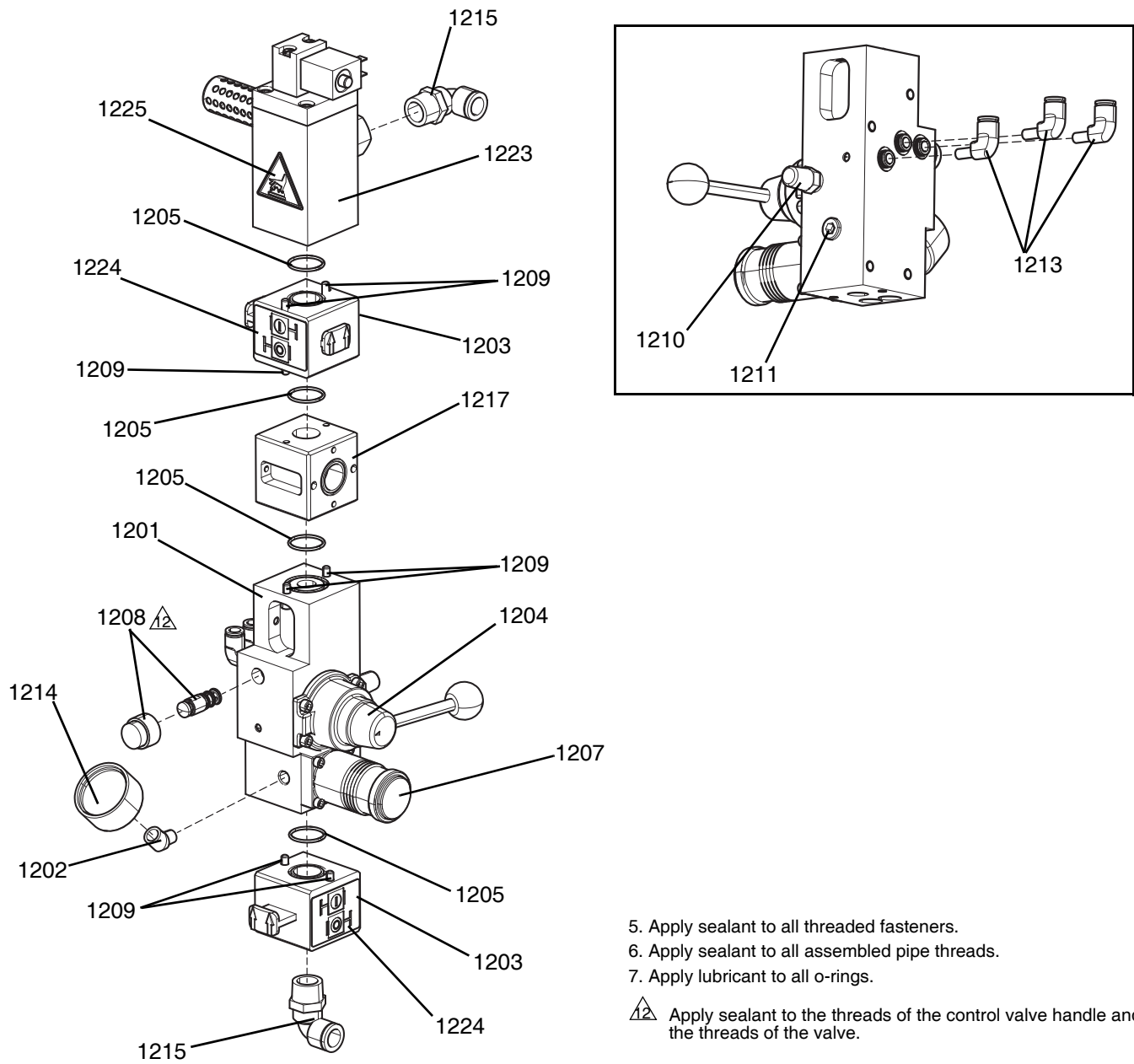

FIG. 17: Secondary Integrated Air Control

Ref	Part	Description	Quantity
1201	---	MANIFOLD, ram, air, 1/2	1
1202	113630	ELBOW, street 45 degree 1/8 npt	1
1203	121793	VALVE, shut-off, modular, 1/2 npt	2
1204	121107	VALVE, control	1
1205	102620	PACKING, o-ring	3
1207	121106	REGULATOR, manifold mounting	1
1208	121109	VALVE, blow-off	1
1209	120039	FASTENER, shcs, 10-32 x .5	10
1210	517449	MUFFLER, sintered, 1/4 npt	1
1211	100721	PLUG, pipe	1
1213	113318	FITTING, elbow, plug in	3
1214	113911	GAUGE, pressure, air	1
1215	15V204	FITTING, elbow, 1/2 npt x 1/2 tube	2
1217	17D478	BLOCK, supply, air, 1/2 in.	1
1223	121948	SOLENOID, air motor, small	1
1224	15V954	LABEL, valve, shutoff, air control	1
1225	189285▲	LABEL, caution	1

--- Not available for individual sale.

▲ Replacement Danger and Warning labels, tags, and cards are available at no cost.

Refer to Air Controls Instructions - Parts manual 312374 for more information.

A and B Pump Assemblies

NOTE: The A pump and B pump use the same parts. The following drawings are of the A pump except where required to show the B pump. The call-outs represent the part locations for both pumps. The pump assembly kit 25A158 is included here and the appropriate call-outs are shown on the kit.

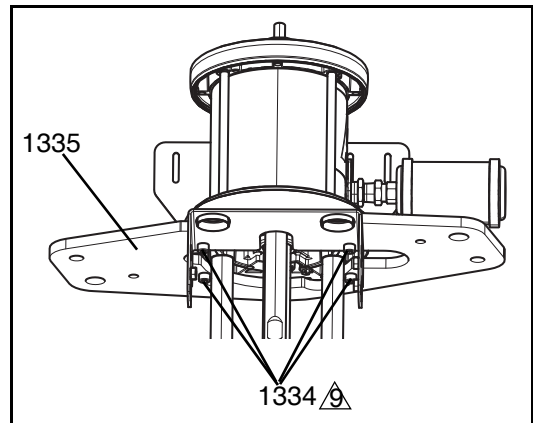
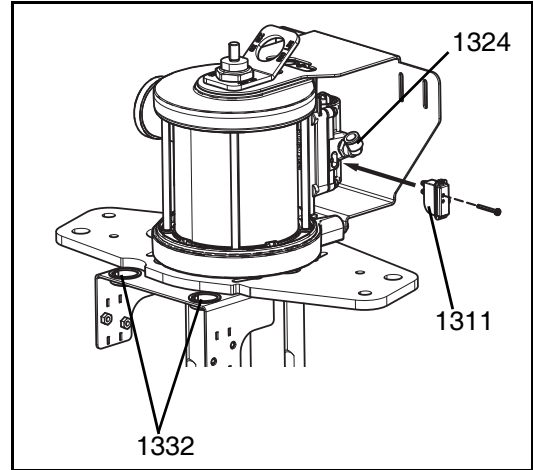
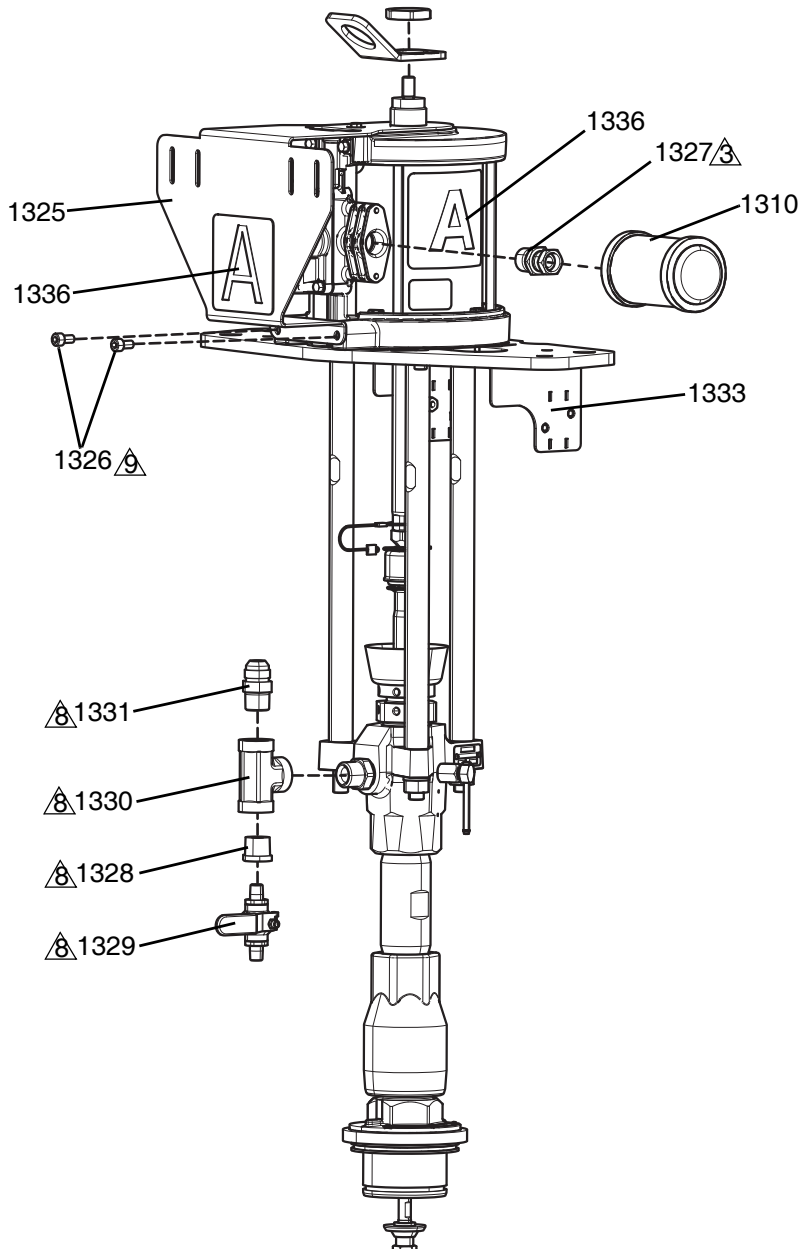



-  Apply sealant.
-  Apply sealant tape
-  Apply blue thread sealant.

FIG. 18: A and B Pump Assembly

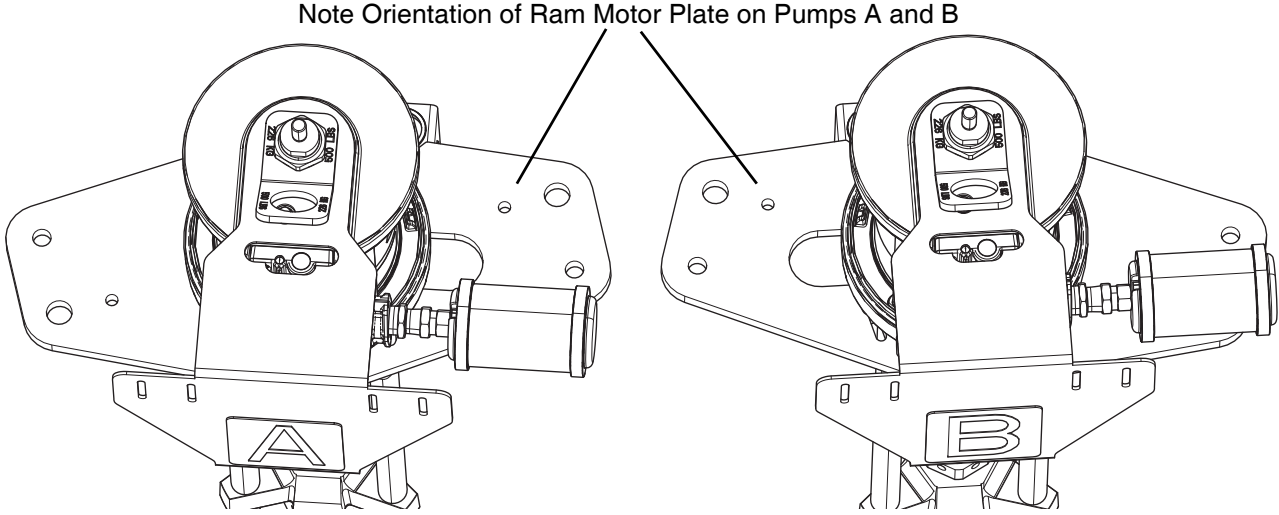

FIG. 19: A and B Pump Plate Alignment

Pump Assembly Kit - 25A158

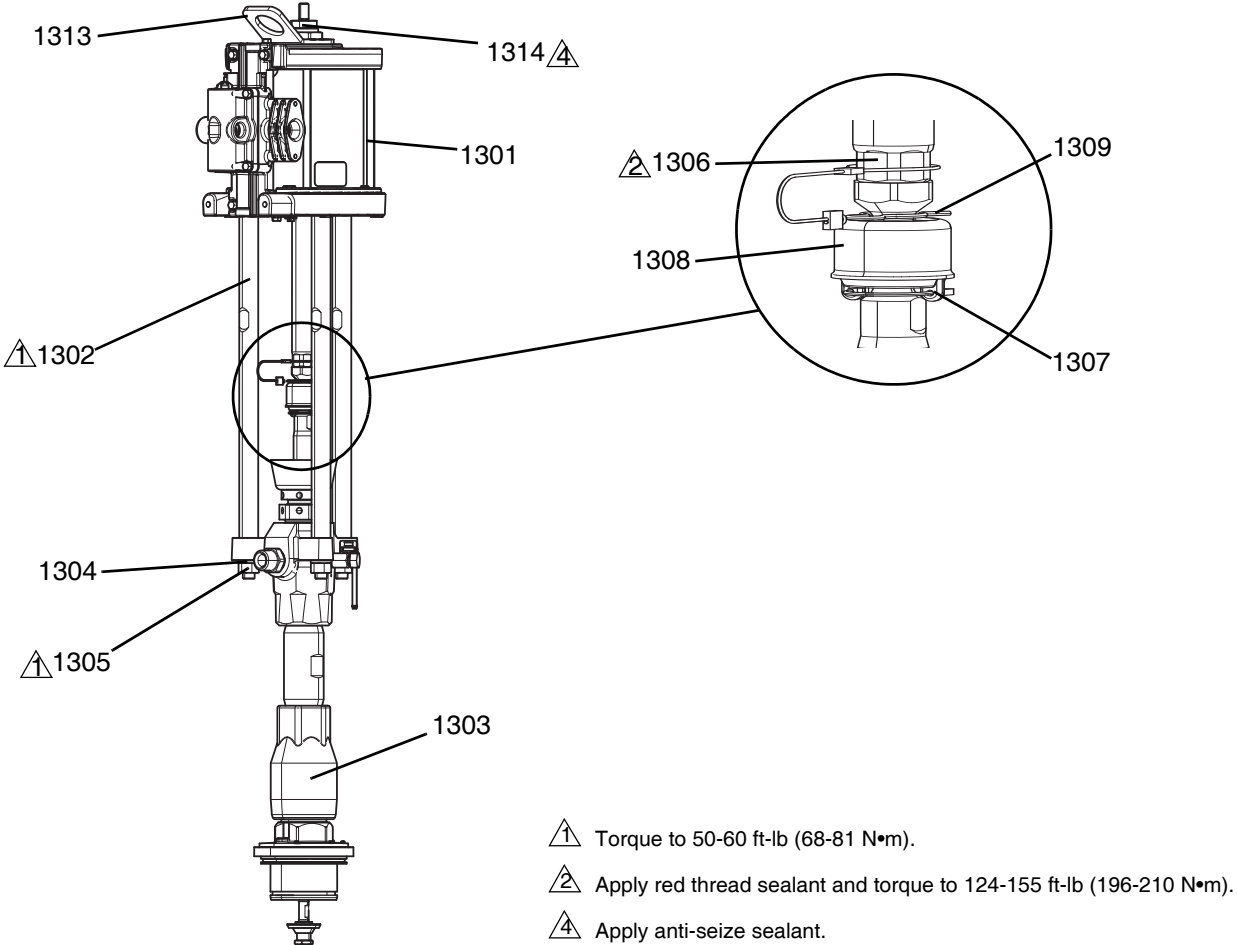

FIG. 20: Pump Assembly Kit

Common Parts

Ref	Part	Description	Quantity
1301	24W754❖	MOTOR, air, 6.0 in, 4.75 strk, blue	1
1302	257360❖	ROD, tie, nxt to cm lower	3
1303	L100SS❖†	LOWER, ss100, severe duty, sst	1
1304	108098❖	WASHER, lock, spring	3
1305	106166❖	NUT, mach, hex	3
1306	15H392❖	ROD, adapter xtreme	1
1307	244819❖	COUPLING, assembly, 145-290 xtreme	1
1308	197340❖	COVER, coupler	1
1309	244820❖	CLIP, hairpin (w/ lanyard)	1
1310	117237	MUFFLER	1
1311	24X441◆	SWITCH, reed, assy	1
1313	15J993❖	RING, lift, plate	1
1314	188784❖	NUT, jam, hex	1
1321	112887*	TOOL, wrench, spanner	1
1324	15V204	FITTING, elbow, 1/2 npt x 1/2 tube	1
1325	24X146	BRACKET, valve, xm, flow meter, paint	1
1326	115264	SCREW, cap, socket head	2
1327	121282	FITTING, swivel, straight, 1/2 f x 3/4 m	1
1328	15M861	FITTING, reducer, pipe, 3/4 x 1/4 sst	1
1329	239018	VALVE, ball, sst	1
1330	113833	TEE, pipe, female	1
1331	15M863	FITTING, connector, male	1
1332	123589	BUSHING, wire protector, snap-in	2
1333	24X241	BRACKET, cable carrier, assy, white	1
1334	109114	SCREW, cap, sch	4
1335	24W794	PLATE, motor, ram, 3.0", 5 gal, white	1
1336	15G476	LABEL, a-b identification	0.5

* Not shown.

† Refer to specific component manual for more details.

❖ Parts are available in kit 25A158.

◆ Parts are available in kit 24X441.

Electronic Enclosure (Control Module) - 24X186

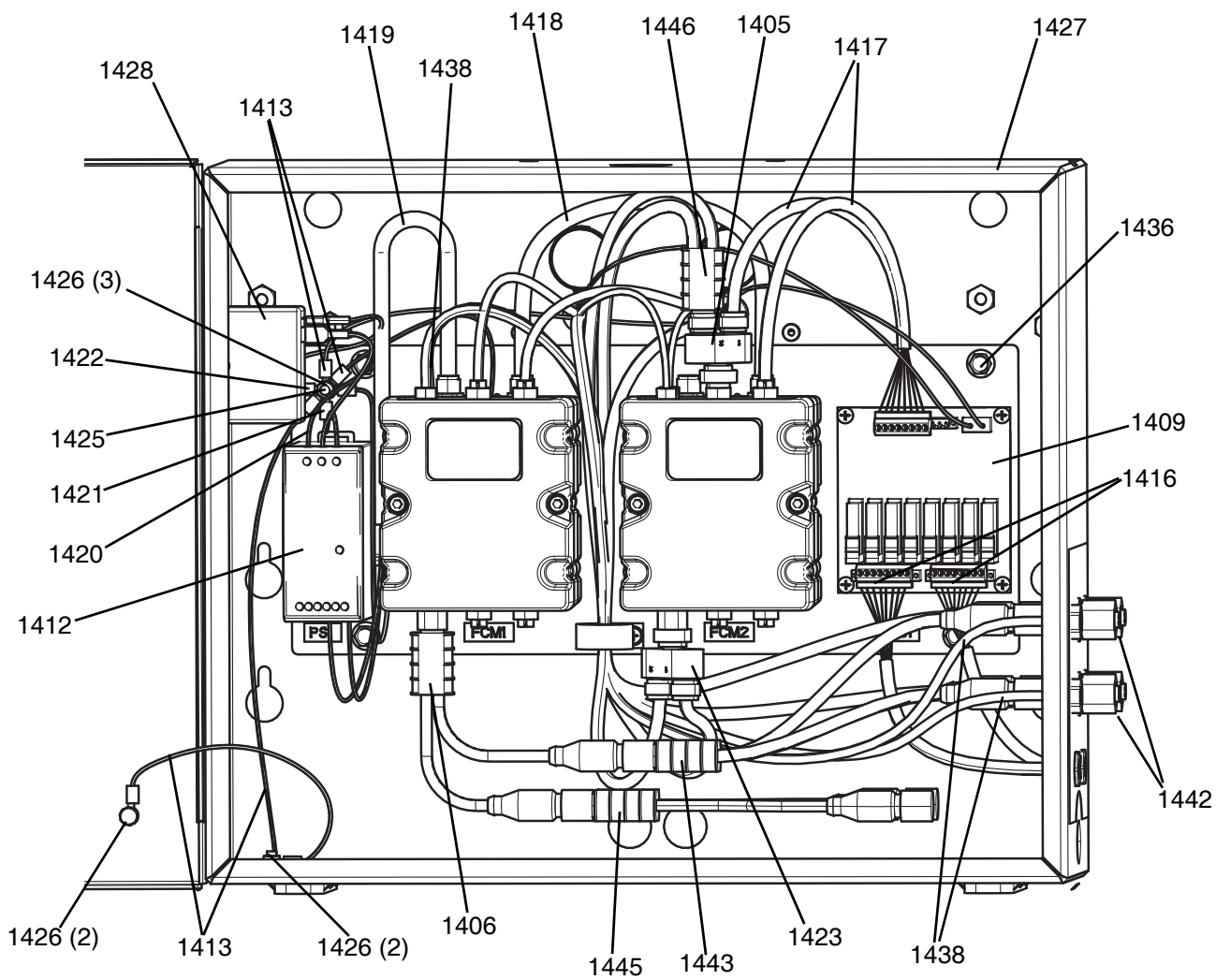

FIG. 21: Electronic Enclosure - Interior

Figure 15 shows parts for the electronic enclosure's control panel and fluid control modules (FCMs)

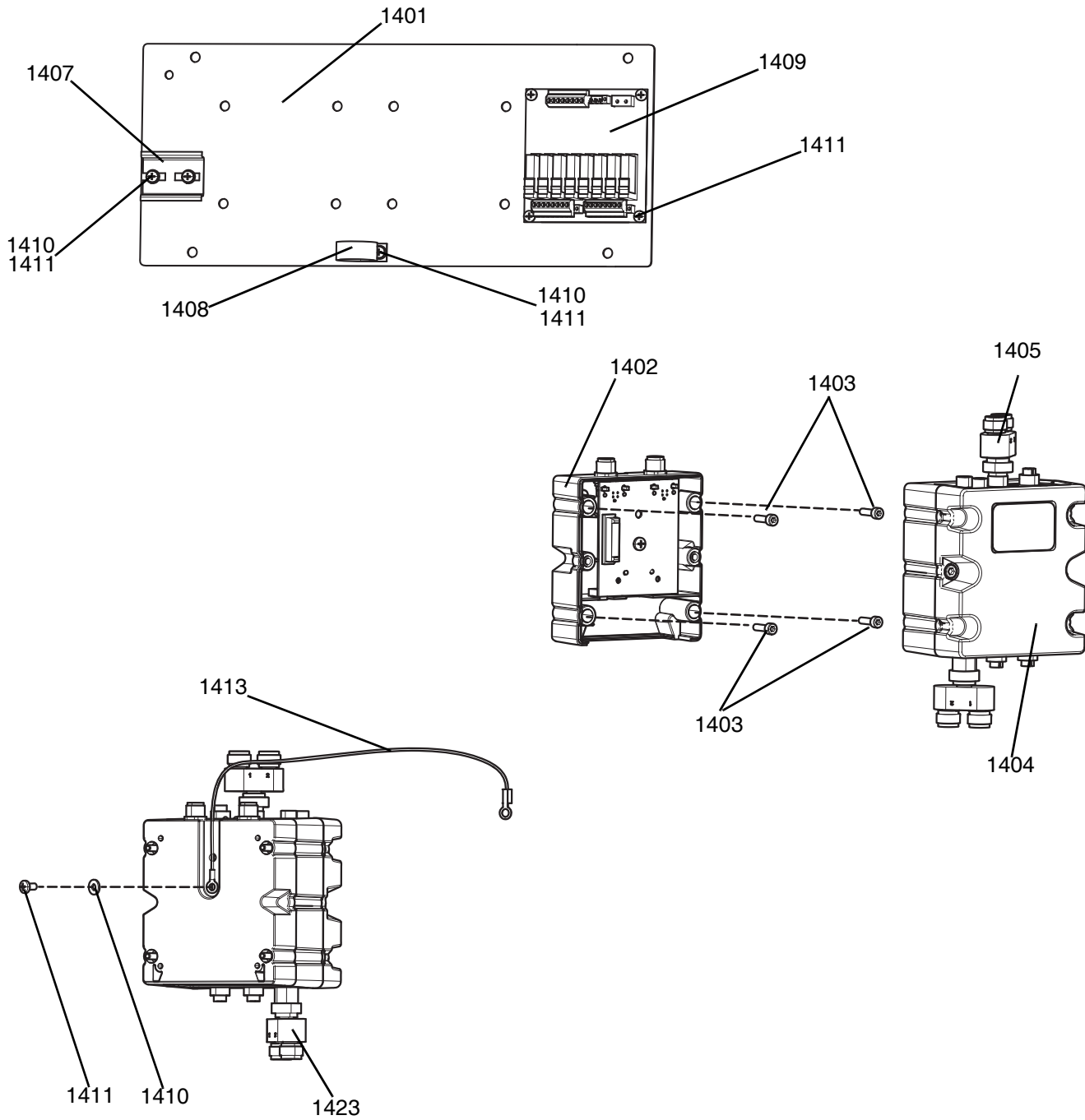

FIG. 22: Electronic Enclosure - Interior Components

Figure 16 shows exterior views of the electronic enclosure including the front, the side with cable connections, and the rear and side with power switch and connection.

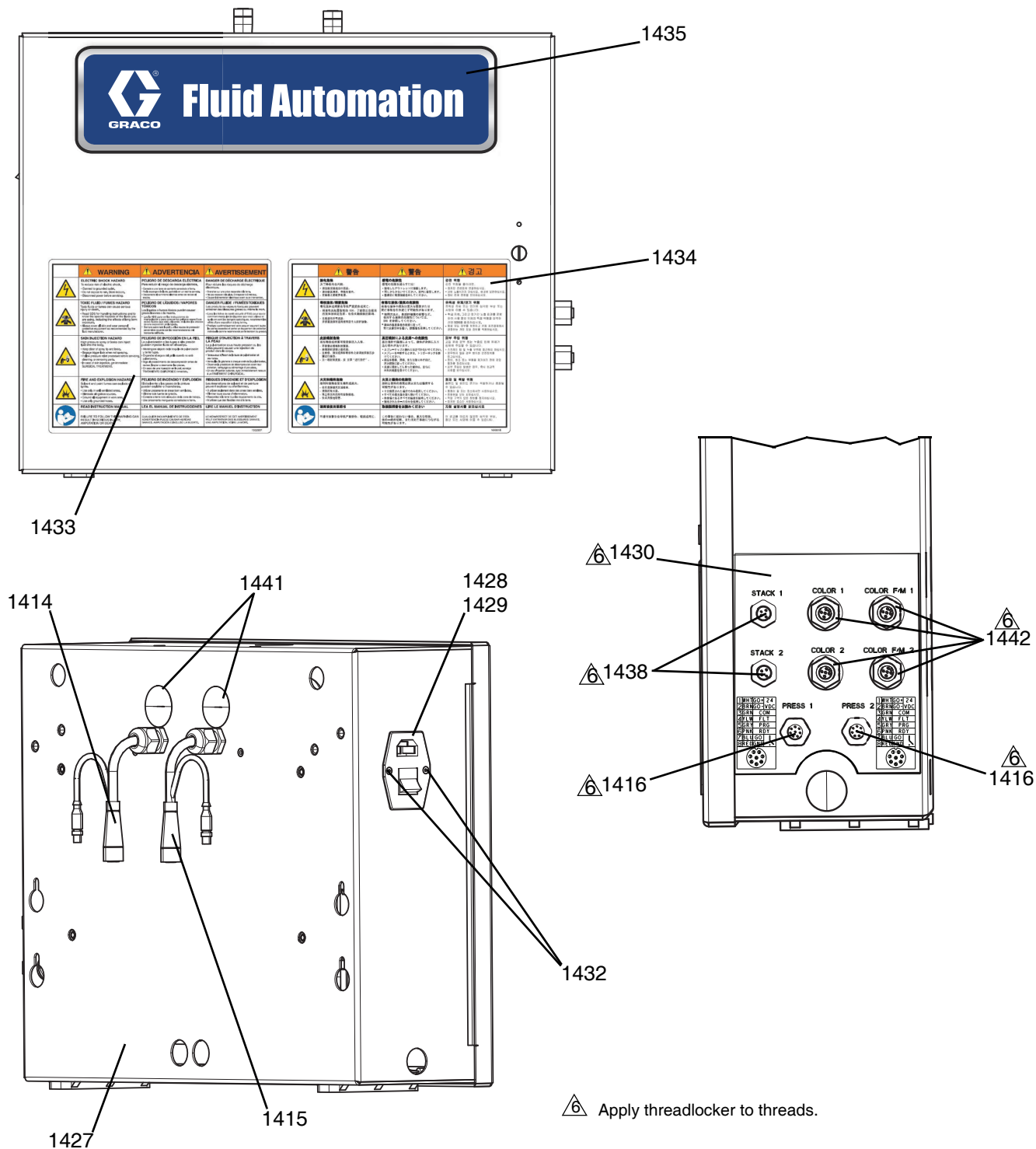

FIG. 23: Electronic Enclosure - Exterior

Common Parts

Ref	Part	Description	Quantity
1401	---	PANEL, electrical, control	1
1402	289697	MODULE, gca, cube, base	2
1403	---	SCREW, cap, socket head	8
1404	289696	MODULE, gca, cube, fcm	2
1405	126520	CONNECTOR, splitter, m 12, 5 p	1
1406	---	CABLE, gca, splitter, m 12 x m 12(2)	1
1407	---	RAIL, din, cut	1
1408	---	STRAP, wire, 1"	1
1409	---❖	MODULE, gca, lsr relay	1
1410	---	WASHER, plain	5
1411	---	SCREW, mach, phil pan hd	9
1412	126453	POWER SUPPLY, 24v	1
1413	---	WIRE, grounding, door	4
1414	---	CABLE, gca, sig, assy, red side	1
1415	---	CABLE, gca, sig, assy, blue side	1
1416	---	CABLE, gca, bulkhead, m 12	2
1417	---	CABLE, gca,	1
1418	---	CABLE, can, female / female 0.5 m	1
1419	17E221	CABLE, gca, can, m 12, 5 p, f	1
1420	---	HARNESS, sing, 16 ga, blk, 7", f/fs	2
1421	---	HARNESS , sing, 16 ga, grn/ylw, 7", r/fs	1
1422	---	HARNESS, sing, 16 ga, grn/ylw, 8", f/r	1
1423	---	CONNECTOR, splitter, m 12, 8 p	1
1425	121013	SCREW, shcs, sst, m 5 x 25 mm	1
1426	120993	NUT, hex, m 5, with tooth washer	7
1427	---	ENCLOSURE, controls, white	1
1428	120910	SOCKET, electrical, w/emi filter	1
1429	114835	FUSE, 4.0 amp, 250 v, time lag	1
1430	---	LABEL,	1
1432	120916	SCREW	2
1433	15G280▲	LABEL, safety, warning, multiple	1
1434	16X831▲	LABEL, safety	1
1435	---	LABEL, identification	1
1436	---	SCREW, mach, hex, flange, m 6 x 1 x 10 mm	4
1438	---	CABLE, gca, m 8, 4 pin, f x m 8, 4 pin, m	2
1441	---	PLUG, hole, 1.250"	2
1442	---	CONNECTOR, thru, m 12, m x f	4
1443	---	CABLE, gca, splitter, m 12, 8 pin, m	1
1445	---	CABLE, gca, splitter, m 12, 8pin, m	1
1446	---	HARNESS, splitter, m 12	1
1447	---*	LABEL, etl, ul 508 a (not shown)	1

--- Not available for individual sale.

* Not shown.

▲ Replacement Danger and Warning labels, tags, and cards are available at no cost.

❖ Replacement relays are available in kit 128452.

Hoses

Part No.	Description	Length in. (cm)	Hose Connection	Material Component
24R213	Hose, Assy, 1/2 x 120, SS	120 (305)	JIC-8	A
24R214	Hose, Assy, 1/2 x 156, SS	156 (396)	JIC-8	
24R215	Hose, Assy, 1/2 x 197, SS	197 (500)	JIC-8	
24R216	Hose, Assy, 3/4 x 120, SS	120 (305)	JIC-12	
24R217	Hose, Assy, 3/4 x 156, SS	156 (396)	JIC-12	
24R218	Hose, Assy, 3/4 x 197, SS	197 (500)	JIC-12	
16U732	Hose, Assy, 1/2 x 120, SS	120 (305)	JIC-8	B
16U733	Hose, Assy, 1/2 x 156, SS	156 (396)	JIC-8	
16U734	Hose, Assy, 1/2 x 197, SS	197 (500)	JIC-8	
16U736	Hose, Assy, 3/4 x 120, SS	120 (305)	JIC-12	
16U737	Hose, Assy, 3/4 x 156, SS	156 (396)	JIC-12	
16U738	Hose, Assy, 3/4 x 197, SS	197 (500)	JIC-12	
16U721	Hose, Assy, 3/8 x 72, SS	72 (183)	JIC-6	Color Hoses
16U447	Hose, Assy, 3/8 x 120, SS	120 (305)	JIC-6	
16U448	Hose, Assy, 3/8 x 138, SS	138 (351)	JIC-6	
16U449	Hose, Assy, 3/8 x 156, SS	156 (396)	JIC-6	
16U450	Hose, Assy, 3/8 x 197, SS	197 (500)	JIC-6	
16V116	Hose, Assy, 3/8 x 236, SS	236 (599)	JIC-6	
16V117	Hose, Assy, 3/8 x 275, SS	275 (699)	JIC-6	

Graco Standard Warranty

Graco warrants all equipment referenced in this document which is manufactured by Graco and bearing its name to be free from defects in material and workmanship on the date of sale to the original purchaser for use. With the exception of any special, extended, or limited warranty published by Graco, Graco will, for a period of twelve months from the date of sale, repair or replace any part of the equipment determined by Graco to be defective. This warranty applies only when the equipment is installed, operated and maintained in accordance with Graco's written recommendations.

This warranty does not cover, and Graco shall not be liable for general wear and tear, or any malfunction, damage or wear caused by faulty installation, misapplication, abrasion, corrosion, inadequate or improper maintenance, negligence, accident, tampering, or substitution of non-Graco component parts. Nor shall Graco be liable for malfunction, damage or wear caused by the incompatibility of Graco equipment with structures, accessories, equipment or materials not supplied by Graco, or the improper design, manufacture, installation, operation or maintenance of structures, accessories, equipment or materials not supplied by Graco.

This warranty is conditioned upon the prepaid return of the equipment claimed to be defective to an authorized Graco distributor for verification of the claimed defect. If the claimed defect is verified, Graco will repair or replace free of charge any defective parts. The equipment will be returned to the original purchaser transportation prepaid. If inspection of the equipment does not disclose any defect in material or workmanship, repairs will be made at a reasonable charge, which charges may include the costs of parts, labor, and transportation.

THIS WARRANTY IS EXCLUSIVE, AND IS IN LIEU OF ANY OTHER WARRANTIES, EXPRESS OR IMPLIED, INCLUDING BUT NOT LIMITED TO WARRANTY OF MERCHANTABILITY OR WARRANTY OF FITNESS FOR A PARTICULAR PURPOSE.

Graco's sole obligation and buyer's sole remedy for any breach of warranty shall be as set forth above. The buyer agrees that no other remedy (including, but not limited to, incidental or consequential damages for lost profits, lost sales, injury to person or property, or any other incidental or consequential loss) shall be available. Any action for breach of warranty must be brought within two (2) years of the date of sale.

GRACO MAKES NO WARRANTY, AND DISCLAIMS ALL IMPLIED WARRANTIES OF MERCHANTABILITY AND FITNESS FOR A PARTICULAR PURPOSE, IN CONNECTION WITH ACCESSORIES, EQUIPMENT, MATERIALS OR COMPONENTS SOLD BUT NOT MANUFACTURED BY GRACO. These items sold, but not manufactured by Graco (such as electric motors, switches, hose, etc.), are subject to the warranty, if any, of their manufacturer. Graco will provide purchaser with reasonable assistance in making any claim for breach of these warranties.

In no event will Graco be liable for indirect, incidental, special or consequential damages resulting from Graco supplying equipment hereunder, or the furnishing, performance, or use of any products or other goods sold hereto, whether due to a breach of contract, breach of warranty, the negligence of Graco, or otherwise.

FOR GRACO CANADA CUSTOMERS

The Parties acknowledge that they have required that the present document, as well as all documents, notices and legal proceedings entered into, given or instituted pursuant hereto or relating directly or indirectly hereto, be drawn up in English. Les parties reconnaissent avoir convenu que la rédaction du présente document sera en Anglais, ainsi que tous documents, avis et procédures judiciaires exécutés, donnés ou intentés, à la suite de ou en rapport, directement ou indirectement, avec les procédures concernées.

Graco Information

Sealant and Adhesive Dispensing Equipment

For the latest information about Graco products, visit www.graco.com.

For patent information, see www.graco.com/patents.

TO PLACE AN ORDER, contact your Graco distributor, go to www.graco.com and select "Where to Buy" in the top blue bar, or call to find the nearest distributor.

If calling from the US: 800-746-1334

If calling from outside the US: 0-1-330-966-3000

All written and visual data contained in this document reflects the latest product information available at the time of publication. Graco reserves the right to make changes at any time without notice.

Original instructions. This manual contains English. MM 335029

Graco Headquarters: Minneapolis

International Offices: Belgium, China, Japan, Korea

GRACO INC. AND SUBSIDIARIES • P.O. BOX 1441 • MINNEAPOLIS MN 55440-1441 • USA

Copyright 2016, Graco Inc. All Graco manufacturing locations are registered to ISO 9001.

www.graco.com

Revision C, January 2017