

Instructions and Parts



ProBell® Air Controllers

3A3954C
EN

For manual or electronic air control of a ProBell rotary applicator as part of a paint coating system. For professional use only.
Not approved for use in explosive atmospheres or hazardous locations.



Important Safety Instructions

Read all warnings and instructions in this manual and in your ProBell® Rotary Applicator manual. **Save these instructions.**

100 psi (0.7 MPa, 7.0 bar) Maximum Air Inlet Pressure

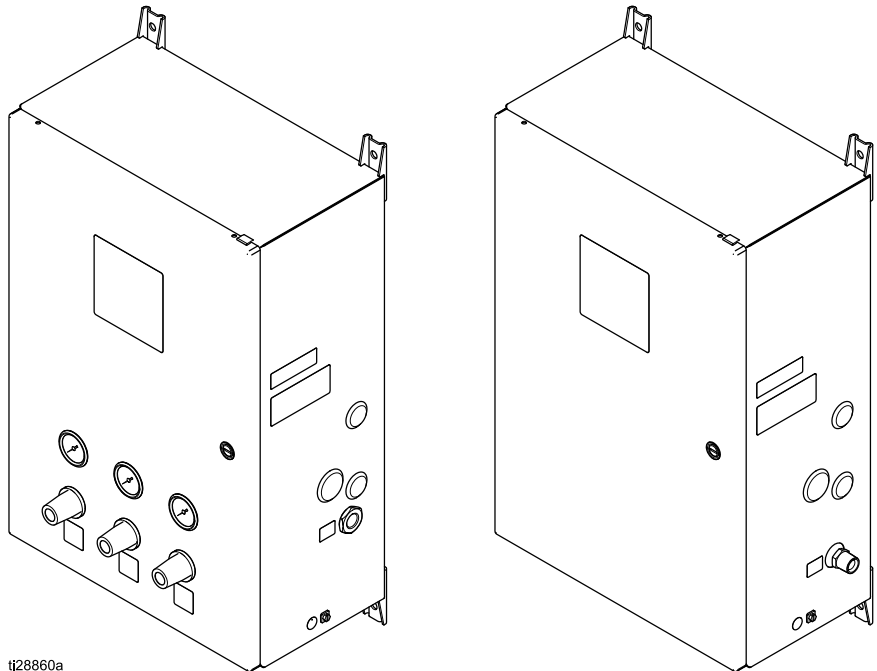

t28860a

PROVEN QUALITY. LEADING TECHNOLOGY.

Contents

Models.....	2	Repair.....	22
Related Manuals	2	Prepare for Service	24
Warnings	3	Replace the Control Module.....	24
ProBell System Information	5	Replace the Trigger or Auxiliary Solenoid	
System Connections and Features	6	Valve	27
Component Identification.....	7	Replace the Voltage to Pressure (V2P)	
Installation.....	9	Regulator	28
Mount the Controller.....	9	Replace a Shaping Air Solenoid Valve	29
Ground the Controller.....	11	Replace the Pressure Switch	30
Controller Connections.....	12	Replace a Pressure Gauge.....	30
Connect Air Lines.....	14	Replace a Pressure Regulator	31
Connect Communication Cables	14	Replace the Bearing Air Filter	31
Connect Power	16	Parts.....	32
Set Air Control Identity	16	Electronic Air Controller (Model	
Wiring the Paint Trigger Input	16	24Z222)	32
Wiring the Optional Interlock Input.....	17	Manual Air Controller (Model 24Z221)	35
Troubleshooting.....	18	Kits and Accessories.....	39
		Technical Specifications.....	41

Models







Model	Description	Certification
24Z221	Manual Air Controller	
24Z222	Electronic Air Controller	





Related Manuals

Manual No.	Description
334452	ProBell® Rotary Applicator, Instructions/Parts
334626	ProBell® Rotary Applicator, Hollow Wrist, Instructions/Parts
3A3657	ProBell® Electrostatic Controller
3A3953	ProBell® Speed Controller
3A3955	ProBell® System Logic Controller
3A4384	ProBell® System CGM Installation Kit
3A4232	ProBell® Cart Systems
3A4346	ProBell® Hose Bundle
3A4738	ProBell® Relective Speed Detection Kit
3A4799A	ProBell® Air Filters Kit

Warnings

The following warnings are for the setup, use, grounding, maintenance, and repair of this equipment. The exclamation point symbol alerts you to a general warning and the hazard symbols refer to procedure-specific risks. When these symbols appear in the body of this manual or on warning labels, refer back to these Warnings. Product-specific hazard symbols and warnings not covered in this section may appear throughout the body of this manual where applicable.

 <h2 style="margin: 0;">WARNING</h2>	
   	<p>FIRE AND EXPLOSION HAZARD</p> <p>Flammable fumes, such as solvent and paint fumes, in the work area can ignite or explode. Paint or solvent flowing through the system can cause static sparking. To help prevent fire or explosion:</p> <ul style="list-style-type: none"> • Electrostatic equipment must be used only by trained, qualified personnel who understand the requirements of this manual. • Ground all equipment, personnel, object being sprayed, and conductive objects in or close to the spray location. Resistance must not exceed 1 megohm. See Grounding instructions. • Do not use pail liners unless they are conductive and grounded. • Always use the required arc detection settings and maintain a safe distance of at least 6 inches (152 mm) between the applicator and the workpiece. • Stop operation immediately if static sparking or repeated arc detection errors occur. Do not use equipment until you identify and correct the problem. • Check applicator resistance and electrical grounding daily. • Use and clean equipment only in a well ventilated location. • Always turn off and discharge the electrostatics when flushing, cleaning or servicing equipment. • Eliminate all ignition sources; such as pilot lights, cigarettes, portable electric lamps, and plastic drop cloths (potential static arc). • Do not plug or unplug power cords or turn lights on or off when flammable fumes are present. • Keep the spray area clean at all times. Use non-sparking tools to clean residue from the booth and hangers. • Keep a working fire extinguisher in the work location. • Interlock the gun air and fluid supply to prevent operation unless ventilation air flow is above the minimum required value. • Interlock the Electrostatic Controller and fluid supply with the booth ventilation system to disable operation if the air flow falls below minimum values. Follow your local codes.
 	<p>ELECTRIC SHOCK HAZARD</p> <p>This equipment must be grounded. Improper grounding, setup, or usage of the system can cause electric shock.</p> <ul style="list-style-type: none"> • Turn off and disconnect power at main switch before disconnecting any cables and before servicing or installing equipment. • Connect only to grounded power source. • All electrical wiring must be done by a qualified electrician and comply with all local codes and regulations.

 <h1 style="margin: 0;">WARNING</h1>	
 	<p>EQUIPMENT MISUSE HAZARD</p> <p>Misuse can cause death or serious injury.</p> <ul style="list-style-type: none"> • Do not operate the unit when fatigued or under the influence of drugs or alcohol. • Do not exceed the maximum working pressure or temperature rating of the lowest rated system component. See Technical Specifications in all equipment manuals. • Use fluids and solvents that are compatible with equipment wetted parts. See Technical Specifications in all equipment manuals. Read fluid and solvent manufacturer's warnings. For complete information about your material, request the Safety Data Sheet (SDS) from distributor or retailer. • Turn off all equipment and follow the Pressure Relief Procedure when equipment is not in use. • Check equipment daily. Repair or replace worn or damaged parts immediately with genuine manufacturer's replacement parts only. • Do not alter or modify equipment. Alterations or modifications may void agency approvals and create safety hazards. • Make sure all equipment is rated and approved for the environment in which you are using it. • Use equipment only for its intended purpose. Call your distributor for information. • Route hoses and cables away from traffic areas, sharp edges, moving parts, and hot surfaces. • Do not kink or over bend hoses or use hoses to pull equipment. • Keep children and animals away from work location. • Comply with all applicable safety regulations.
	<p>PERSONAL PROTECTIVE EQUIPMENT</p> <p>Wear appropriate protective equipment when in the work location to help prevent serious injury, including eye injury, hearing loss, inhalation of toxic fumes, and burns. This protective equipment includes but is not limited to:</p> <ul style="list-style-type: none"> • Protective eyewear, and hearing protection. • Respirators, protective clothing, and gloves as recommended by the fluid and solvent manufacturer.

ProBell System Information

The ProBell Air Controller is an optional component in the ProBell Rotary Applicator system. The Electronic Air Controller sends air activation signals for the paint, dump, and solvent (cup wash) valves. It also electronically controls the inner and outer shaping air pressures. The Manual Air Controller controls all air in the system. Manual air regulators are used to set the turbine and shaping air pressures.



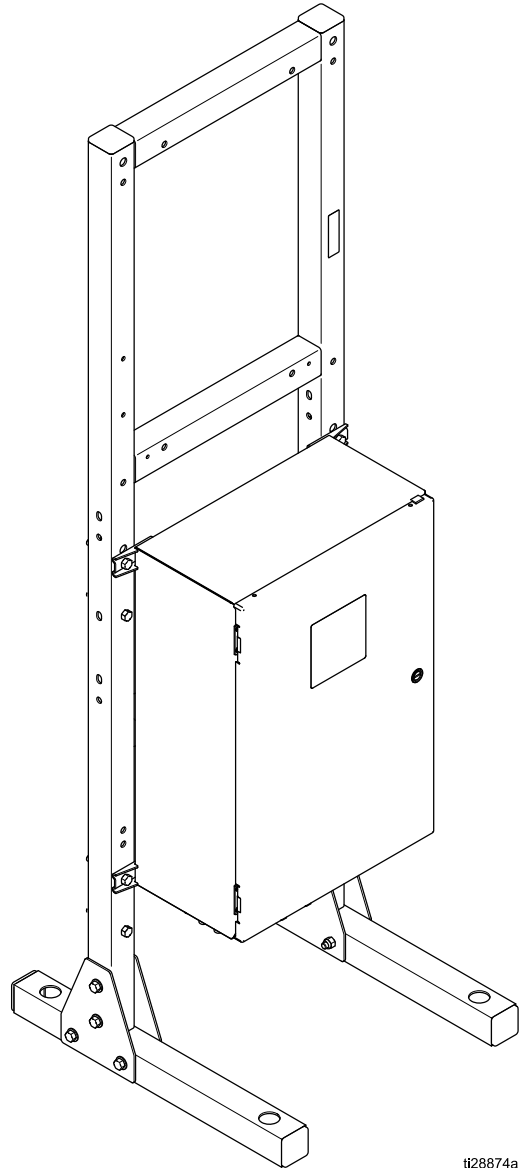





- This manual covers information specific to the Air Controllers. It includes information on installation, troubleshooting, repair, and parts.
- See the ProBell Rotary Applicator manual (334452 or 334626) for all system information, including installation and connection of the whole system, required interlocks, system grounding, required electrical tests, and operation procedures.
- See the System Logic Controller Manual (3A3955) for details on how to set up parameters for the Air Controller.



t28874a

Figure 1 ProBell Electronic Air Controller, shown on Cart (sold separately)

System Connections and Features

Air Line	Port Label	Speed Controller Connections	Electronic Air Controller Connections	Manual Air Controller Connections
B (Bearing Air)		√*		√*
BK (Braking Air)		√		
BR (Bearing Air Return)		√*		√*
DT (Dump Valve Trigger)			√	√
PT (Paint Valve Trigger)			√	√
SI (Shaping Air Inner)			√	√
SO (Shaping Air Outer)			√	√
ST (Solvent Trigger)			√	√
TA (Turbine Air)		√*		√*
Auxiliary Triggers (for system flexibility)	1, 2, 3,		√	√

* In systems with a speed controller, bearing air, bearing air return, and turbine air must be used from the speed controller, not the manual air controller.

Component Identification

Electronic Air Controller

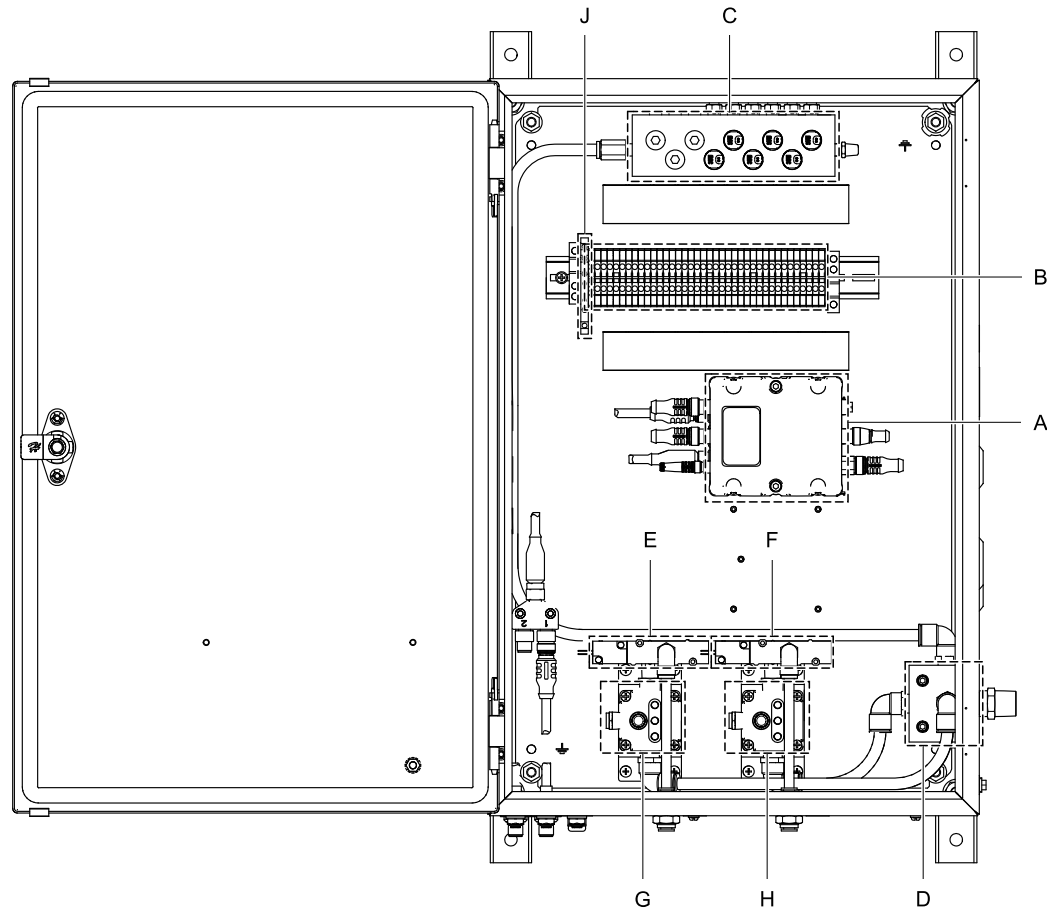

028915a

Ref.	Component	Description
A	Control Module	Manages the operation of all air controller components
B	Terminal Blocks	Provides electrical wire connections
C	Solenoid Valves	Sends air activation signals for paint, dump, and solvent valves; auxiliary signals available for system flexibility
D	Air Manifold	Directs incoming air to the controller components

Ref.	Component	Description
E	Inner Shaping Air Solenoid Valve	Shuts off the flow of the inner shaping air
F	Outer Shaping Air Solenoid Valve	Shuts off the flow of the outer shaping air
G	Voltage to Pressure Regulator	Converts voltage to pressure for the inner shaping air
H	Voltage to Pressure Regulator	Converts voltage to pressure for the outer shaping air
J	Optocoupler	Isolates input to the trigger paint valve from the PLC

Manual Air Controller

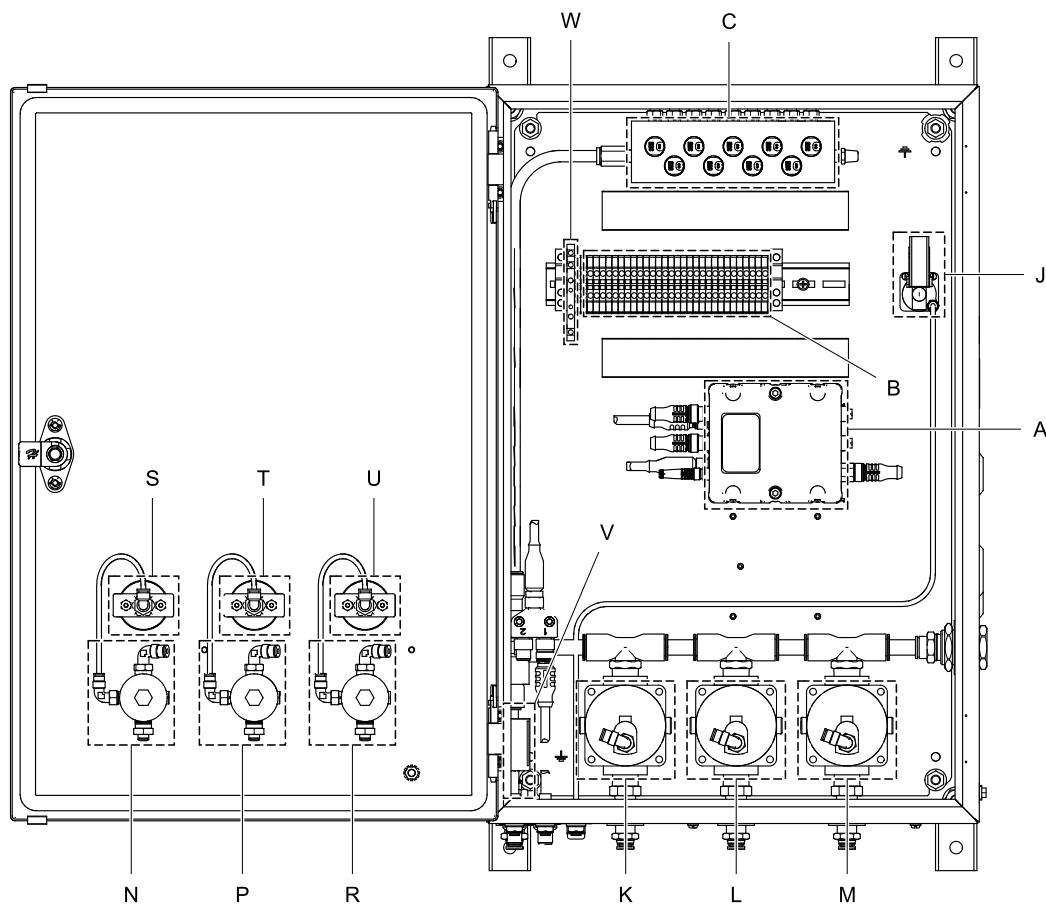

ti28914a

Ref.	Component	Description
A	Control Module	Manages the operation of all air controller components
B	Terminal Blocks	Provides electrical wire connections
C	Solenoid Valves	Sends air activation signals for paint, dump, and solvent valves; auxiliary signals available for system flexibility
J	Pressure Switch	Verifies that the bearing air is at least 70 psi
K	High-Flow Remote	Piloted regulator for turbine air
L	High-Flow Remote	Piloted regulator for inner shaping air
M	High-Flow Remote	Piloted regulator for outer shaping air

Ref.	Component	Description
N	Outer Shaping Air Regulator	Air pressure signal to regulator M
P	Inner Shaping Air Regulator	Air pressure signal to regulator L
R	Turbine Air Regulator	Air pressure signal to regulator K
S	Outer Shaping Air Gauge	
T	Inner Shaping Air Gauge	
U	Turbine Air Gauge	
V	Air Filter	Supplementary coalescing air filter that protects the bearing from any particles that get through the main air filtering system
W	Optocoupler	Isolates input to the trigger paint valve from the PLC

Installation

Mount the Controller

				
To reduce the risk of fire or explosion, do not install equipment approved only for a non-hazardous location in a hazardous location.				

NOTE: Install the air controller in a non-hazardous location only.

The air controller can be mounted on the control box stand or on a wall. The box comes with four mounting brackets installed in a vertical orientation. Remove and turn the brackets if a horizontal orientation works better for your installation.

Wall Mounting

The pre-installed mounting brackets can be used to mount the controller on any flat wall. Mount the air controller in the non-hazardous area, as close to the applicator as possible, to minimize pressure loss in the air lines.

1. Determine the mounting location. Ensure that the wall is strong enough to support the weight of the mounting bracket and the controller. See [Technical Specifications, page 41](#).
2. See the dimensions or use the box as a template to mark the mounting hole locations.
3. Drill holes and use four screws to attach the controller to the wall.

Electronic Air Controller

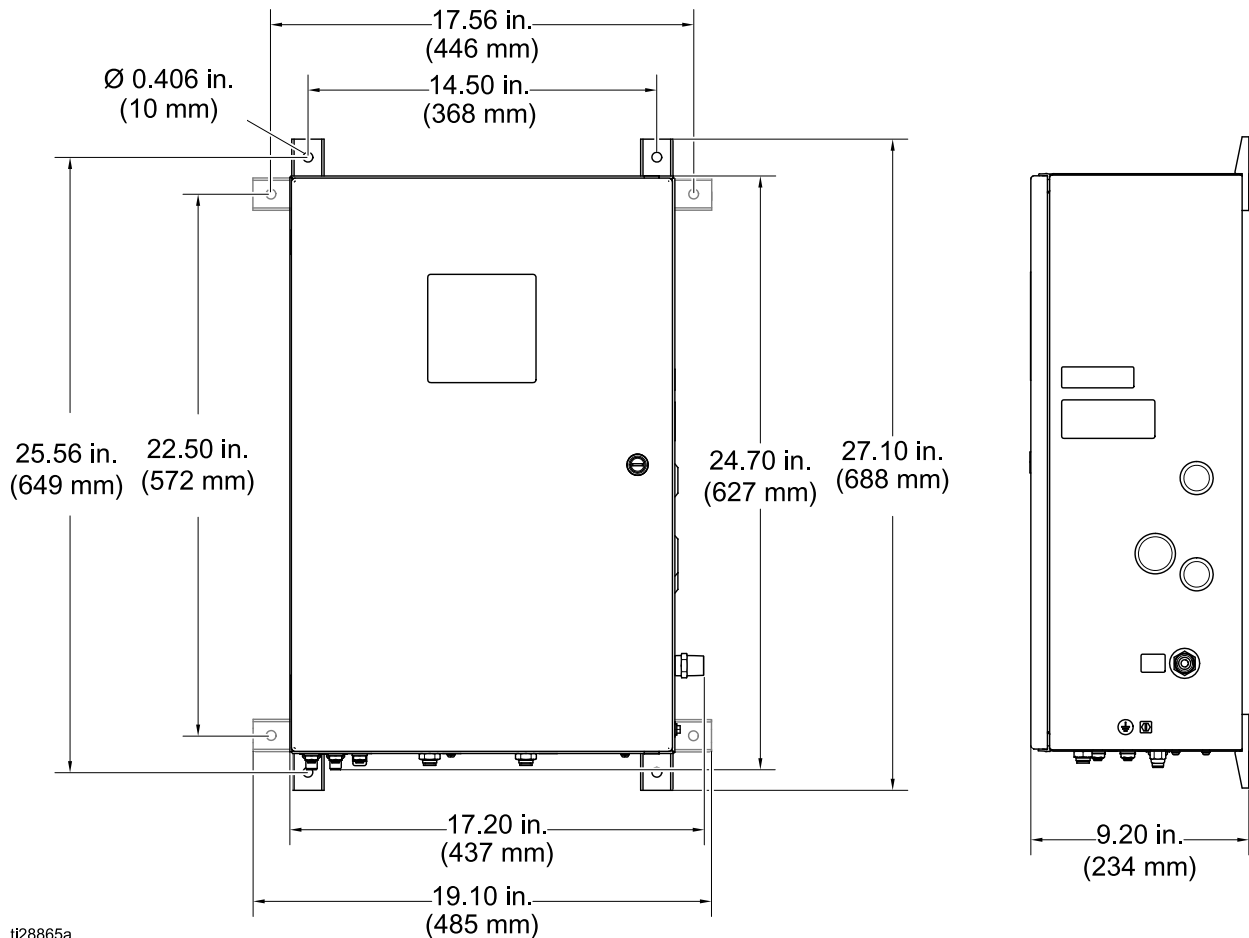

Manual Air Controller

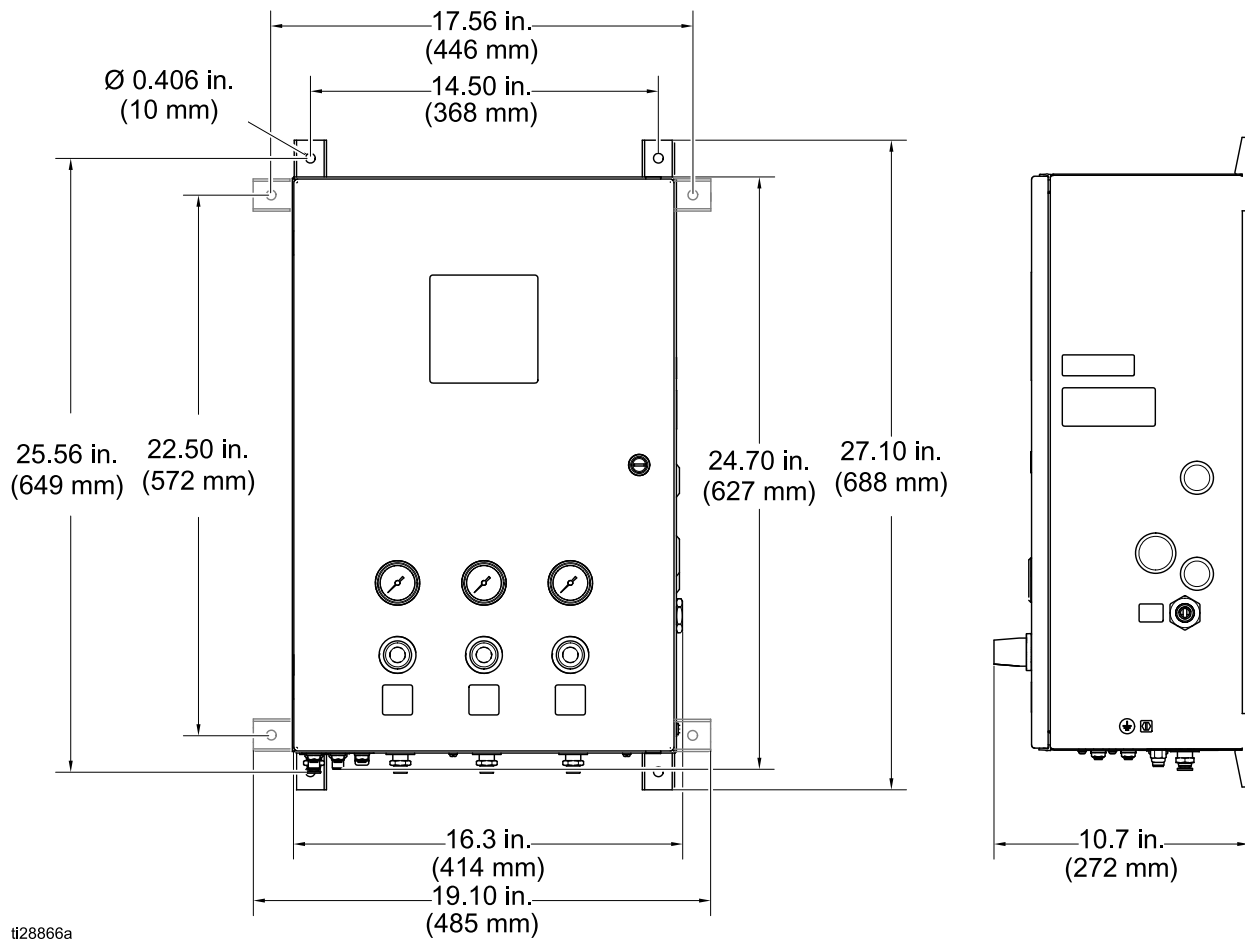

ti28866a





Cart Mounting

For some ordering options, the air controller is mounted on the cart at the factory. If the cart was ordered separately, follow these steps:

1. Remove the four mounting brackets. Turn them so they are oriented horizontally. Reattach them to the air controller box.

2. Use four screws (provided with the cart) to mount the air controller box on the cart in the location shown in Figure 1. See [ProBell System Information, page 5](#).

Ground the Controller

				
<p>The equipment must be grounded to reduce the risk of static sparking and electric shock. Electric or static sparking can cause fumes to ignite or explode. Improper grounding can cause electric shock. Grounding provides an escape wire for the electric current.</p>				

For full system grounding instructions and requirements, see the ProBell Rotary Applicator manual (334452 or 334626). Use the provided ground wire and clamp to ground the air controller to a true earth ground.

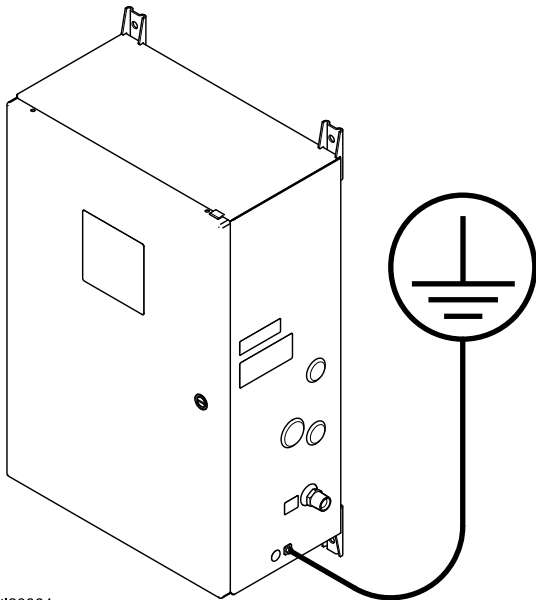

ti28864a

Figure 2 Electronic Air Controller Grounding Location

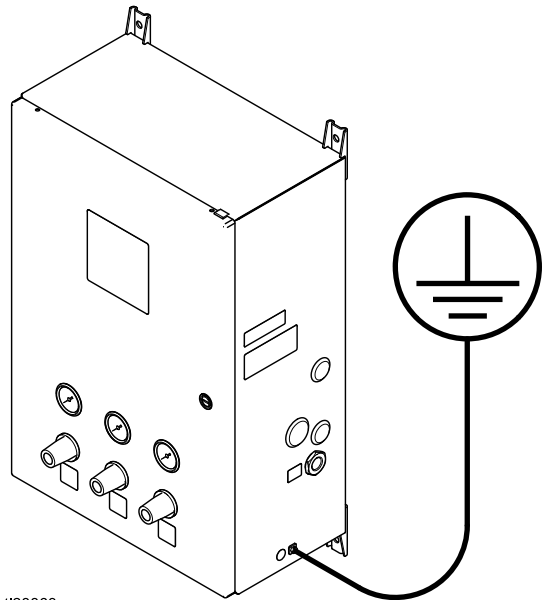

ti28863a

Figure 3 Manual Air Controller Grounding Location

Controller Connections

Overview

Air control in your ProBell system will use one of the following setups:

- All air control is provided by the Graco Manual Air Controller.
- Air controls are split between the Graco Electronic Air Controller and the Graco Speed Controller. Be sure that your system includes a power supply (sold separately) to be mounted on either controller.

- Your system uses a combination of Graco controllers and your existing devices. Air control will then require a combination of the connections shown in the figures and use of the auxiliary triggers. Be sure that your system includes a power supply (sold separately). See [ProBell System Information, page 5](#) for all system connection information.

Manual Air Controller

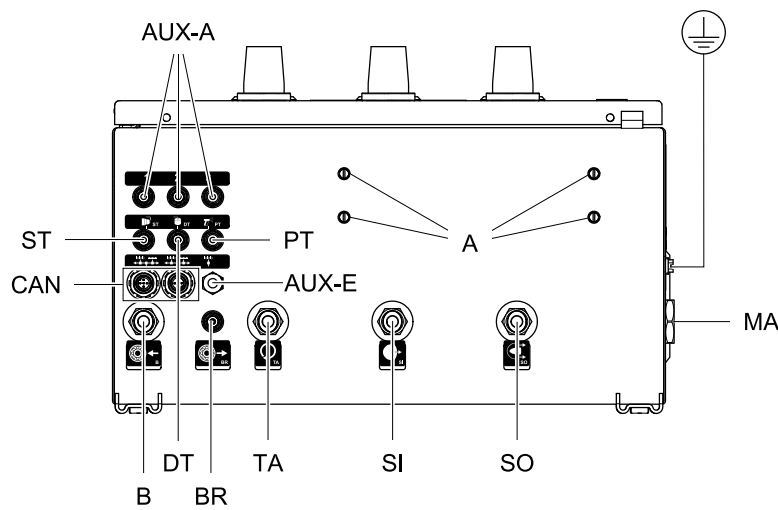





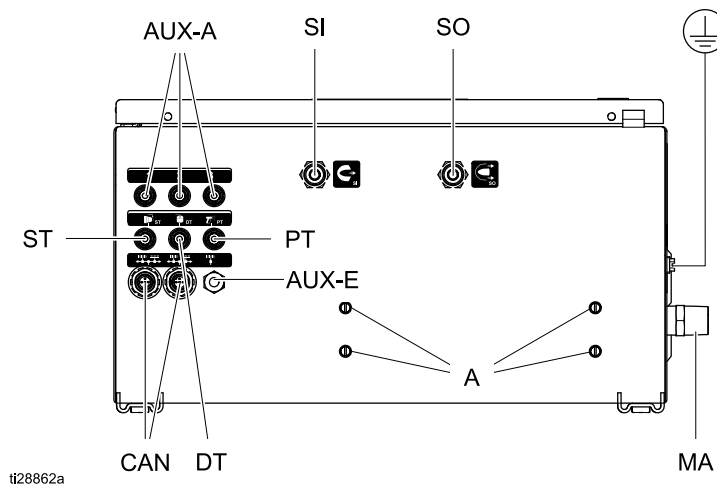



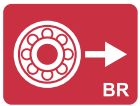
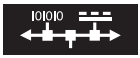

ti28861a

Electronic Air Control

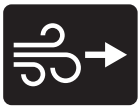

ti28862a

Table 1 Key for Cable Connections, Electrical or Manual Air Controller

Ref.	Port Label	Label Color	Description
A			Mounting Holes for Power Supply.
AUX-A	Ports 1-3	Black	Auxiliary Air Ports — Use 4 mm (5/32 in) tubing.
AUX-E		Black	Auxiliary port for optional optocoupler wiring.
B		Red	Bearing Air — Use 8 mm (5/16 in) OD tube.
BR		Red	Bearing Air Return – Use 4 mm (5/32 in) tubing.
CAN		Black	Graco CAN/Power (24VDC)
DT		White	Dump Valve Trigger – Use 4 mm (5/32 in) tubing.
MA		Black	Main Air Port — 1/2 in. npt
PT		Green	Paint Valve Trigger – Use 4 mm (5/32 in) tubing.
SI		Gray	Shaping Air Inner — Use 8 mm (5/16 in.) tubing.
SO		Blue	Shaping Air Outer — Use 8 mm (5/16 in.) tubing.
ST		Black	Solvent Trigger (Cup Wash) – Use 4 mm (5/32 in) tubing.
TA		Brown	Turbine Air — Use 8 mm (5/16 in.) tubing with 1 mm (0.04 in) wall to minimize pressure drop.

Connect Air Lines

Graco Air Controllers are labeled with the same reference letters as the applicator, for easier matching.

NOTICE

Use filtered air to prevent contamination of the paint finish and to prevent damage to the air bearing. Air that is not adequately filtered can clog bearing air passages and cause bearing failure. The ProBell Rotary Applicator Manual contains detailed filtering specifications.

NOTE: For the turbine air (TA), bearing air (B), shaping air inner (SI) and shaping air outer (SO) lines, use 8 mm (5/16 in) OD tube with 1 mm (0.04 in) wall. For the bearing air return (BR) and the three triggers (DT, PT, and ST), use 4 mm (5/32 in) tube.

NOTICE

Take great care to connect the air lines to the correct ports. Incorrect air line connections will damage the applicator.

1. Connect all nine required air lines to the applicator first. See your applicator manual for instructions.
2. **Air Activation Signal Lines (DT, PT, ST):** Connect the lines that provide air activation signals for the dump valve (DT), the paint valve (PT) and the solvent valve (ST).
3. **Shaping Air Lines (SI, SO):** Connect the lines that provide the shaping air inner (SI) and the shaping air outer (SO).
4. **Turbine Air (TA), Bearing Air (B), and Bearing Air Return (BR):**
 - **Electronic Air Controller:** Connect these air line to the Graco speed controller (if present) or to another air control device in your system.
 - **Manual Air Controller:** Connect these air lines to the ports with the matching labels.
5. Connect the main air supply line into the main air fitting (MA, Ref. 7) on the side of the box.

NOTE: Once the air is applied, it will flow freely out Port B. The controller has no option to turn this air off. (Manual Controller only)

Connect Communication Cables

The air controllers (Manual or Electronic) communicate to the rest of the system over Graco CAN cables. Each component and the power supply must be on the Graco CAN network. The best connection pattern depends on whether the Air Controller is electronic or manual.

1. Connect a Graco CAN cable from Electrostatic Controller (CC) to the System Logic Controller (DD).
2. If the power supply is attached to the Air Controller, install the termination resistor (201) on the splitter inside the box. **NOTE:** If the Air Controller was purchased as part of a system, the termination resistor will be installed at the factory. If not, the resistor comes with the power supply.
3. **Manual Air Controller:**
 - a. Connect a Graco CAN cable from the power supply (AA) to the right (inside) port on the Air Controller (BB).
 - b. Connect a Graco CAN cable from the other port on the Air Controller (BB) to the Electrostatic Controller (CC).

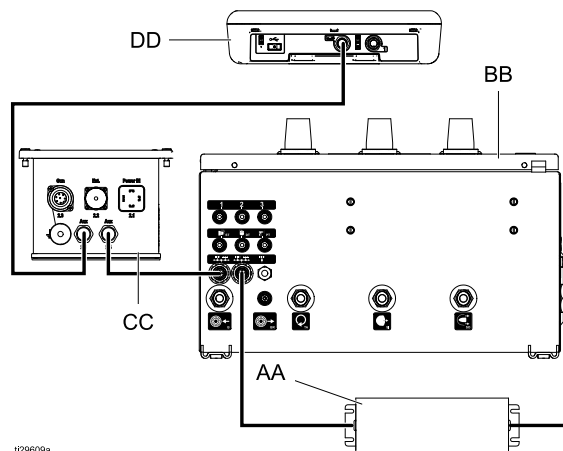

4. **Electronic Air Controller (with Speed Controller):**
 - a. Connect a Graco CAN cable from the power supply (AA) to the lower/rear port on the Speed Controller (EE)
 - b. Connect a Graco CAN cable from the Speed Controller (EE) to the Air Controller (BB).
 - c. Connect a Graco CAN cable from the Air Controller (BB) to the Electrostatic Controller (CC).

One Gun Wiring

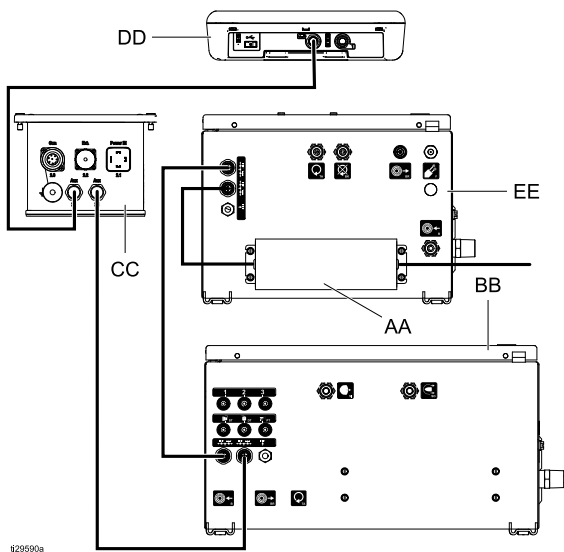

Two Gun Wiring

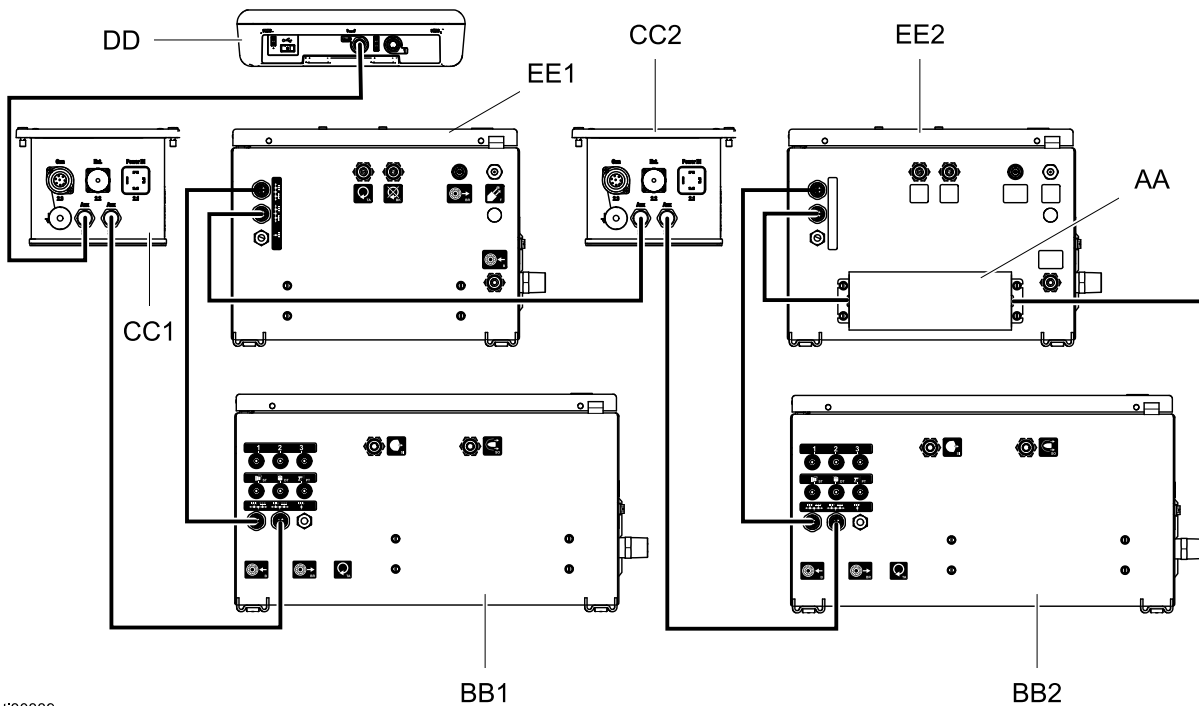

Other configurations (not shown) are possible. Follow these rules when building the CAN network.

- Connect controllers in series.
- A termination resistor must be installed on the power supply port.
- Remove any other termination resistors from the system.
- Set IDs on all boxes.

Connect Power

One power supply is required in the Graco CAN network, typically mounted on the bottom of the Speed Controller, or the Manual Air Controller.

1. Connect a power cord to the power supply connector. A cord suitable for use in North America is provided with the power supply. See [Technical Specifications, page 41](#). The power supply is sold separately from the air controllers, but included in system purchases.
2. Connect the other end of the cord to AC power. See [Technical Specifications, page 41](#), for more information.

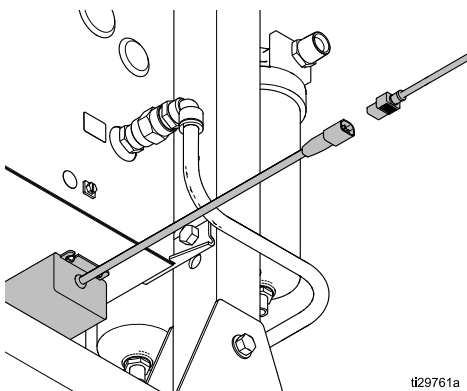

Set Air Control Identity

The air controller comes preset from the factory to control one applicator. In two-applicator systems, the identity of the control module must be set in order to communicate with the system properly.

1. Remove plug (24) to access control module rotary switch by pushing from the inside of the box with a screwdriver.
2. Using a screwdriver, set the control module rotary switch to "1" for the air controller that controls the second applicator.

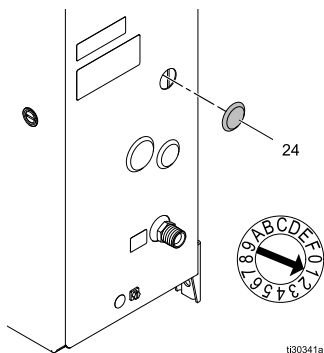

3. Replace the plug.
4. Restart the system by removing and reapplying power.

Wiring the Paint Trigger Input

The Paint Trigger Input provides a means to signal the System Logic Controller to activate the paint trigger solenoid. This normally open (maintained) contact provides a signal to the system to indicate whether or not to trigger spray device or spray device is triggered (Input Only). If the input is OPEN the system deactivates paint trigger solenoid. The input must be maintained CLOSED to activate paint trigger solenoid.

NOTE: The Paint Trigger discrete input must be enabled on the System Logic Controller. If it is set to 'Local' or 'Network', the discrete input is ignored and the spray device trigger signal is handled via the network communications, or manually. See System Logic Controller manual 3A3955.

The Paint Trigger Input uses an optocoupler to protect the Graco ProBell air control box from outside voltages.

- Optocoupler ports 13+ and 14 are wired to the control module.
- Optocoupler ports A1+ and A2- are wired to the external device or PLC.

Apply the 24 VDC signal to A1+ and GND to A2-. Only one A2- port needs to be connected to GND, as the two ports labeled A2- are connected internally.

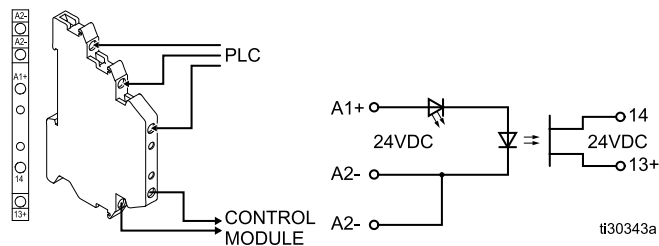

A1+ (relative to A2-)	Function
24 VDC	Paint Trigger Active
Less than 13.5 VDC	Paint Trigger Inactive

Wiring the Optional Interlock Input

The Optional Interlock Input provides a means to signal the System Logic Controller to stop the ProBell system. This normally open contact turns the applicator off when activated. If the ProBell air controller reads the input as CLOSED it interrupts system operation and puts the gun into Gun Off mode. If the input is read as OPEN, the system operates normally.

The optional interlock optocoupler does not come pre-installed and must be purchased and installed separately. Install kit 24Z226 to use the Optional Interlock Input.

For each ProBell Air Controller, the Interlock Input is on different terminal blocks. Remove the wires in the existing terminal blocks and install in the Optocoupler ports as shown below.

	Terminal Block	
	Manual Air Controller	Electronic Air Controller
Optocoupler Port 14	9	8
Optocoupler Port 13+	10	9

NOTICE

To prevent damage to equipment, do not use these terminal blocks without an optocoupler present.

The Optional Interlock Input uses an optocoupler to protect the Graco ProBell air control box from outside voltages.

- Optocoupler ports 13+ and 14 are wired to the control module.
- Optocoupler ports A1+ and A2- are wired to the external device or PLC.

Apply the 24 VDC signal to A1+ and GND to A2-. Only one A2- port needs to be connected to GND, as the two ports labeled A2- are connected internally.

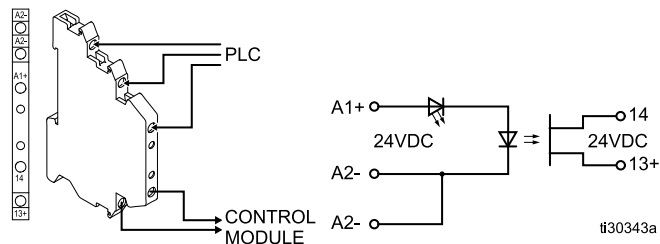

A1+ (relative to A2-)	Function
24 VDC	Interlock Activated (system stop)
Less than 13.5 VDC	Interlock Inactive (system run)

Troubleshooting

Table 2 Control Module LED Diagnostics

Module Status LED Signal	Diagnosis	Solution
Green on	The system is powered up.	— — —
Yellow	Internal communication is in progress.	— — —
Red solid	Hardware failure	Replace the module.
Red flashing fast	The system is uploading software.	— — —
Red flashing slow	Token error	Remove the token and upload the software token again.

Table 3 Communication Errors

Code	Event Type	Name	Description	Solution
CAP1 or CAP2	Alarm	Communication Error Air Control	The System Logic Controller has lost communication with the air controller.	<ul style="list-style-type: none"> • Verify Graco CAN connection on bottom of the Air Controller. • Check status LEDs on the control module. • Cycle power.
CA00	Alarm	Communication Error Logic Controller	System Logic Controller communication has been lost.	Verify Graco CAN connection on the System Logic Controller
CDP1 or CDD2	Alarm	Duplicate Air Controller	The System Logic Controller identifies two or more air controllers set to the same gun.	<ul style="list-style-type: none"> • The air controller has the same CAN ID as another module. • Adjust the selector switch on the Control Module. See Set Air Control Identity, page 16 for instructions.
WSC1 or WSC2	Alarm	Incorrect Air Control Configuration	The air control identifies a V2P feedback signal on a Manual Air Controller.	<ul style="list-style-type: none"> • Verify that the air control type is correct. See the Gun Screen 2 section of the ProBell System Logic Controller manual 3A3955. • Replace the control module if needed.

Table 4 Electronic Shaping Air Errors

Code	Event Type	Name	Description	Solution
P111 or P112	Alarm	Pressure Low, Air 1 (Inner)	Actual air pressure 1 is lower than the alarm limit for longer than the alarm time (as set on Gun Screen 2).	Verify shaping air 1 (inner) hose is not cut or split.
P121 or P122	Alarm	Pressure Low, Air 2 (Outer)	Actual air pressure 2 is lower than the alarm limit for longer than the alarm time (as set on Gun Screen 2).	Verify shaping air 2 (outer) hose is not cut or split.
P211 or P212	Deviation	Pressure Low, Air 1 (Inner)	Actual air pressure 1 is lower than the deviation limit for longer than the deviation time (as set on Gun Screen 2).	Verify shaping air 1 (inner) hose is not cut or split.
P221 or P222	Deviation	Pressure Low, Air 2 (Outer)	Actual air pressure 2 is lower than the deviation limit for longer than the deviation time (as set on Gun Screen 2).	Verify shaping air 2 (outer) hose is not cut or split.
P311 or P312	Deviation	Pressure High, Air 1 (Inner)	Actual air pressure 1 is higher than the deviation limit for longer than the deviation time (as set on Gun Screen 2).	<ul style="list-style-type: none"> • Calibrate the voltage to pressure regulator. See the System Logic Controller manual. • Verify air tubing is connected properly. • Verify cable connection between voltage to pressure (V2P) regulator and connector 6 on the control module. Retry calibration. • Replace the V2P regulator.
P321 or P322	Deviation	Pressure High, Air 2 (Outer)	Actual air pressure 2 is higher than the deviation limit for longer than the deviation time (as set on Gun Screen 2).	
P411 or P412	Alarm	Pressure High, Air 1 (Inner)	Actual air pressure 1 is higher than the alarm limit for longer than the alarm time (as set on Gun Screen 2).	
P421 or P422	Alarm	Pressure High, Air 2 (Outer)	Actual air pressure 2 is higher than the alarm limit for longer than the alarm time (as set on Gun Screen 2).	
P511 or P512	Alarm	Calibration Error, Inner Shaping Air	The returned value of the inner shaping air calibration is out of range.	<ul style="list-style-type: none"> • Relieve inlet air pressure. Retry calibration. See System Logic Controller manual.
P521 or P522	Alarm	Calibration Error, Outer Shaping Air	The returned value of the outer shaping air calibration is out of range.	<ul style="list-style-type: none"> • Verify cable connection between voltage to pressure (V2P) regulator and connector 6 on the control module. Retry calibration. • Replace cable 17K902. • Replace voltage to pressure regulator

Code	Event Type	Name	Description	Solution
P611 or P612	Alarm	Sensor Disconnected, Inner Shaping Air	The returned value of the pressure sensor for inner shaping air is zero	<ul style="list-style-type: none"> • Replace cable 17K902. • Replace voltage to pressure regulator
P6Y1 or P6Y2	Alarm	Sensor Disconnected, Outer Shaping Air.	The returned value of the pressure sensor for outer shaping air is zero.	

Table 5 Solenoid Errors

Code	Event Type	Name	Description	Remedy
WJ31 or WJ32	Alarm	Paint Solenoid Removed	System does not detect the Paint Trigger solenoid.	Electronic: Verify wiring on terminals 1 and 3. Manual: Verify wiring on terminals 1 and 2.
WJ41 or WJ42	Alarm	Dump Solenoid Removed	System does not detect the Dump Trigger solenoid.	Electronic: Verify wiring on terminals 4 and 5. Manual: Verify wiring on terminals 5 and 6.
WJ51 or WJ52	Alarm	Cup Wash Solenoid Removed	System does not detect the Cup Wash solenoid.	Electronic: Verify wiring on terminals 6 and 7. Manual: Verify wiring on terminals 7 and 8.
WJ61 or WJ62	Alarm	Inner Shaping Air Solenoid Removed	System does not detect the Shaping Air 1 (inner) solenoid.	Electronic: Verify wiring on terminals 13 and 14. Manual: Verify wiring on terminals 17 and 18.
WJ71 or WJ72	Alarm	Outer Shaping Air Solenoid Removed	System does not detect the Shaping Air 2 (outer) solenoid.	Electronic: Verify wiring on terminals 20 and 21. Manual: Verify wiring on terminals 20 and 21.
WJ81 or WJ82	Alarm	Turbine Air Solenoid Removed	System does not detect the Turbine Air solenoid, Manual Air Controller.	Manual: Verify wiring on terminals 3 and 4 in the Manual Air Controller.
WJ91 or WJ92	Alarm	Auxiliary 1 Solenoid Removed	System does not detect the Auxiliary 1 solenoid.	Electronic: Verify wiring on terminals 27 and 28. Manual: Verify wiring on terminals 23 and 24.
WJA1 or WJa2	Alarm	Auxiliary 2 Solenoid Removed	System does not detect the Auxiliary 2 solenoid.	Electronic: Verify wiring on terminals 29 and 30. Manual: Verify wiring on terminals 25 and 26.
WJB1 or WJB2	Alarm	Auxiliary 3 Solenoid Removed	System does not detect the Auxiliary 3 solenoid.	Electronic: Verify wiring on terminals 31 and 32. Manual: Verify wiring on terminals 27 and 28.

Table 6 Bearing Air Pressure Errors (Manual Air Controller Only)

Code	Event Type	Name	Description	Solution
P9P1 or P9P2	Alarm	Air Control Pressure Low	Air Controller no longer detects bearing air. (Manual air controller only.)	Verify that inlet air pressure and flow are sufficient.

Table 7 Maintenance Advisories

Code	Event Type	Name	Description	Remedy
MD11	Advisory	Maintenance Valve Paint Gun 1	Gun 1 paint valve is due for maintenance.	<ul style="list-style-type: none"> • Perform required maintenance • Clear advisory and clear valve count on corresponding Maintenance Screen
MD12	Advisory	Maintenance Valve Paint Gun 2	Gun 2 paint valve is due for maintenance.	
MD21	Advisory	Maintenance Valve Dump Gun 1	Gun 1 dump valve is due for maintenance.	
MD22	Advisory	Maintenance Valve Dump Gun 2	Gun 2 dump valve is due for maintenance.	
MD31	Advisory	Maintenance Valve Cup Wash Gun 1	Gun 1 cup wash valve is due for maintenance.	
MD32	Advisory	Maintenance Valve Cup Wash Gun 2	Gun 1 cup wash valve is due for maintenance.	
MD41	Advisory	Maintenance Valve Air 1 Gun 1	Gun 1 Air 1 valve is due for maintenance.	
MD42	Advisory	Maintenance Valve Air 1 Gun 2	Gun 2 Air 1 valve is due for maintenance.	
MD51	Advisory	Maintenance Valve Air 2 Gun 1	Gun 1 Air 2 valve is due for maintenance.	
MD52	Advisory	Maintenance Valve Air 2 Gun 2	Gun 2 Air 2 valve is due for maintenance.	
MD61	Advisory	Maintenance Valve Auxiliary 1 Gun 1	Gun 1 Auxiliary 1 valve is due for maintenance.	
MD62	Advisory	Maintenance Valve Auxiliary 1 Gun 2	Gun 2 Auxiliary 1 valve is due for maintenance.	
MD71	Advisory	Maintenance Valve Auxiliary 2 Gun 1	Gun 1 Auxiliary 2 valve is due for maintenance.	
MD72	Advisory	Maintenance Valve Auxiliary 2 Gun 2	Gun 2 Auxiliary 2 valve is due for maintenance.	
MD81	Advisory	Maintenance Valve Auxiliary 3 Gun 1	Gun 1 Auxiliary 3 valve is due for maintenance.	
MD82	Advisory	Maintenance Valve Auxiliary 3 Gun 2	Gun 2 Auxiliary 3 valve is due for maintenance.	
MD91	Advisory	Maintenance Valve Turbine Gun 1	Gun 1 Turbine valve is due for maintenance	
MD92	Advisory	Maintenance Valve Turbine Gun 2	Gun 2 Turbine valve is due for maintenance	
MMUX	Advisory	Maintenance USB Logs Full	USB maintenance logs are full.	

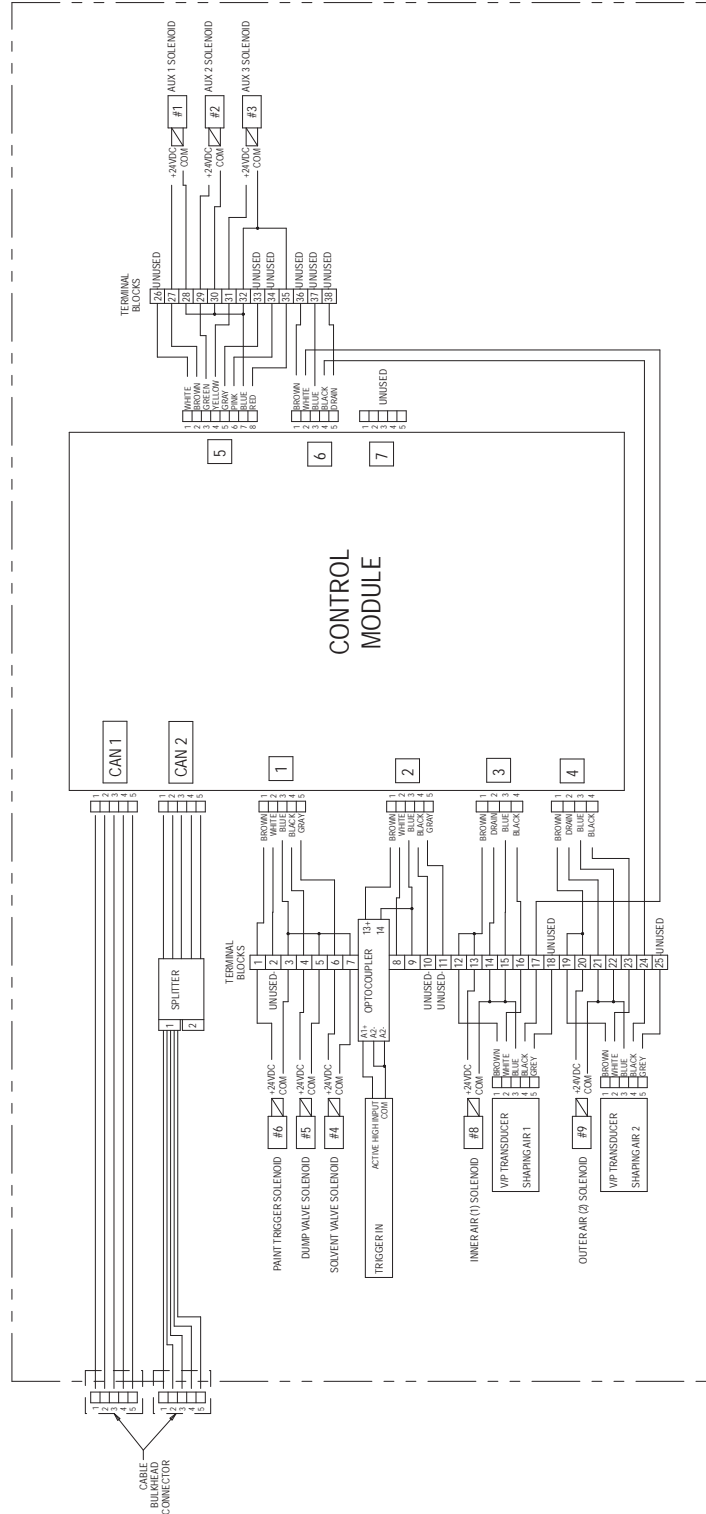
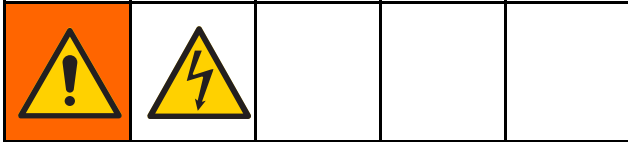

Figure 5 Electronic Air Controller

Prepare for Service



- To avoid electric shock, remove power from the system before servicing.
- All electrical wiring must be done by a qualified electrician and comply with all local codes and regulations.
- Do not substitute or modify system components.
- Read [Warnings, page 3](#).

NOTICE

To avoid equipment damage, the bearing air must be on while the turbine is spinning and must not be turned off until the cup comes to a complete stop.

1. Verify that the cup is not rotating.
2. Close the air shutoff valve on the air controller air supply line.
3. Unplug the power supply.

Replace the Control Module

Follow these instructions to replace the control module (Refs. 2 and 6). Order Kit 25C423, which includes the module and the necessary software token.

1. Follow directions at [Prepare for Service, page 24](#).
2. Label each cable with the number of the connection port. Disconnect all cables from both the base module (2) and the cube module (6).
3. Remove the module door (5).
4. Loosen the fasteners (6a) and remove the control module (6).
5. Remove fasteners (3 and 4), then remove the base (2).
6. Install the new base (2). Tighten fasteners (3 and 4).
7. Install the new control module (6). Tighten the fasteners (6a).
8. Reinstall the module door (5).
9. Refer to the labels to reconnect each cable. If you did not use labels, remove the wire duct cover. Refer to the schematic and the following table for connection information.
10. Load the correct software onto the control module, using the token.

NOTICE

The module will not work if the software is not installed. See directions in the System Logic Controller manual (3A3955) for loading the software.

Table 8 Replace Control Module, Electronic Air Controller

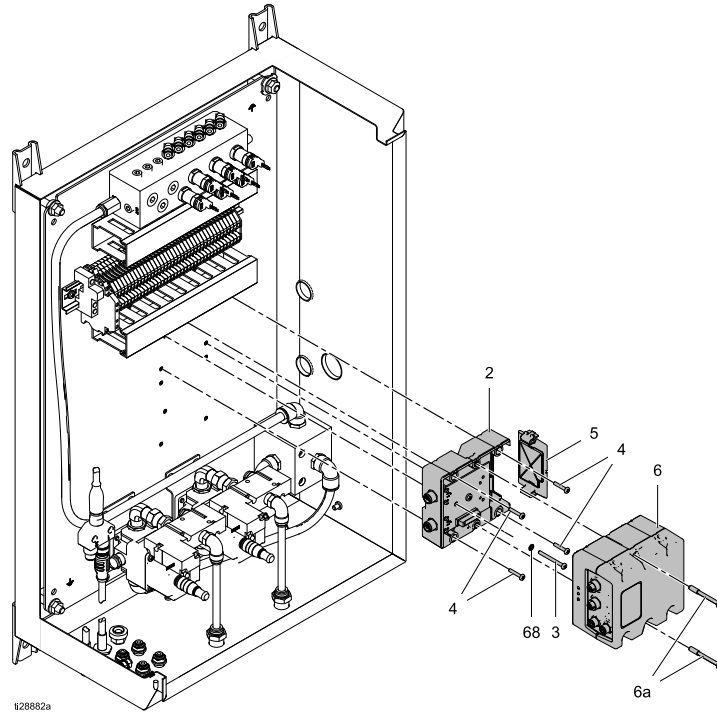
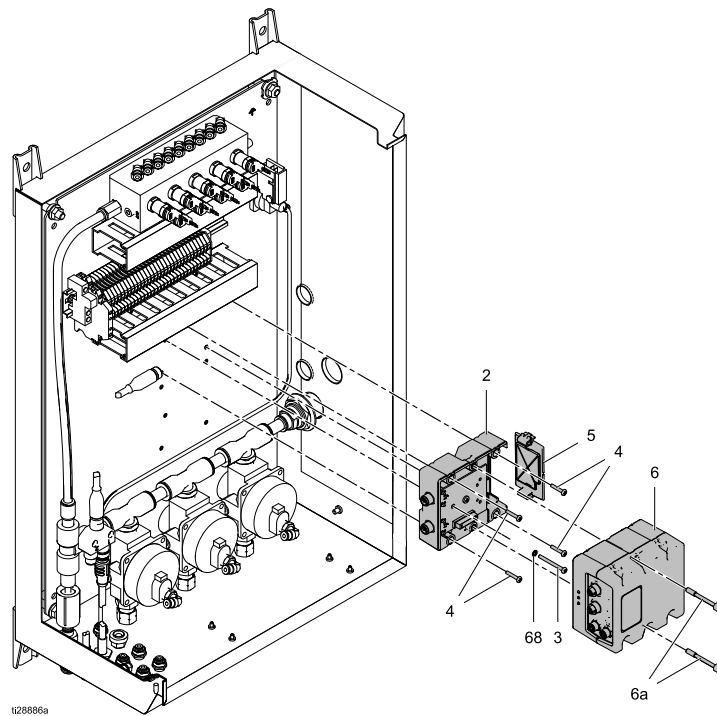
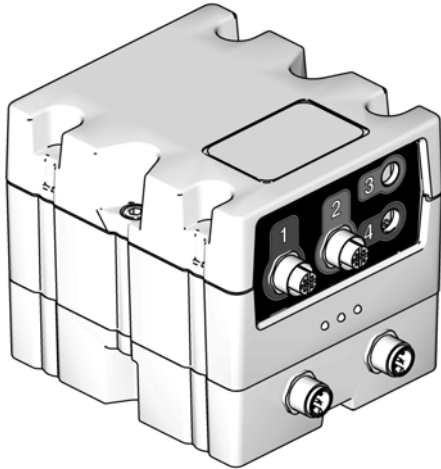

Table 9 Replace Control Module, Manual Air Controller



Front Side



Back Side

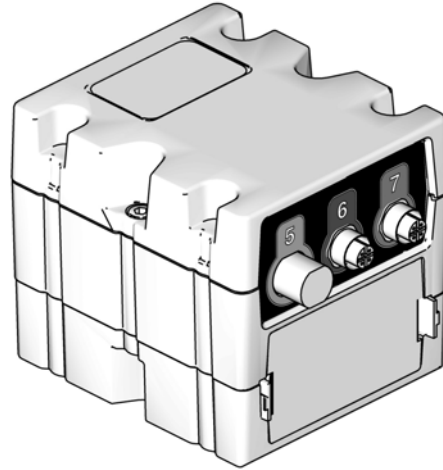

Table 10 Electronic Air Controller

Module Connection	Purpose	System Connection
1	Paint Trigger Solenoid	Terminal Blocks 1 and 3
	Dump Trigger Solenoid	Terminal Blocks 4 and 5
	Solvent Trigger Solenoid	Terminal Blocks 6 and 7
2	Trigger In	Optocoupler
3	Shaping Air Inner Solenoid and V2P Regulator	Terminal Blocks 12–17
4	Shaping Air Outer Solenoid and V2P Regulator	Terminal Blocks 19–24
5	Auxiliary Solenoids	Terminal Blocks 27–32, 35
6	V2P Regulator Pressure Feedback	None
7		Unused

Table 11 Manual Air Controller

Module Connection	Purpose	System Connection
1	Turbine Air Solenoid	Terminal Blocks 1 and 2
	Paint Trigger Solenoid	Terminal Blocks 3 and 4
	Dump Trigger Solenoid	Terminal Blocks 5 and 6
	Solvent Trigger Solenoid	Terminal Blocks 7 and 8
2	Trigger In	Optocoupler
	Pressure Switch	Terminal Blocks 11–13
3	Shaping Air Inner Solenoid	Terminal Blocks 14–15
4	Shaping Air Outer Solenoid	Terminal Blocks 18–19
5	Auxiliary Solenoids	Terminal Blocks 23–27, 28, and 31
6		Unused
7		Unused

Replace the Trigger or Auxiliary Solenoid Valve

1. Follow directions at [Prepare for Service, page 24](#).
2. Disconnect the electrical wires. See the following table:
3. Remove the solenoid (34).
4. Install a new solenoid (34). Connect the line power and the COM wire to the two terminal blocks listed. It doesn't matter which wire goes to which terminal. See table.
5. Test the new solenoid using maintenance screens on the System Logic Controller. See manual 3A3955, System Logic Controller, for more information.

Table 12 Wire Connections, Solenoids 4–7

Solenoid	Terminal Blocks	
	Electronic Controls	Manual Controls
4 — Solvent	6 and 7	7 and 8
5 — Dump	4 and 5	5 and 6
6 — Paint	1 and 3	1 and 2
7 — Turbine	N/A	3 and 4

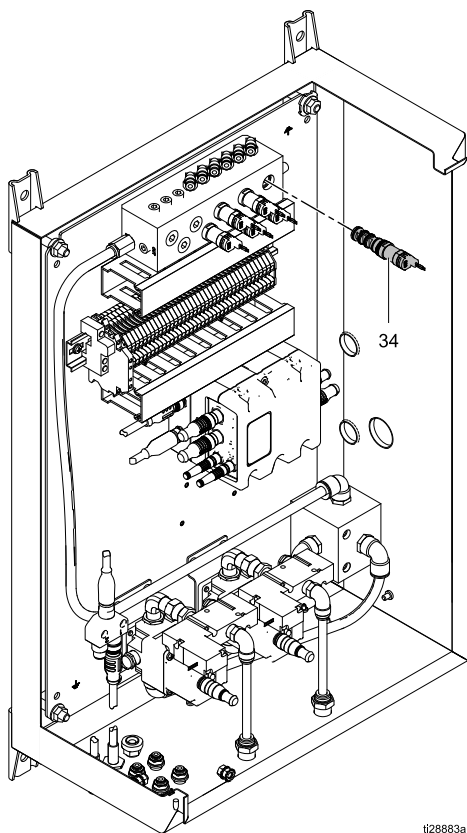

ti28883a

Electronic Air Controller

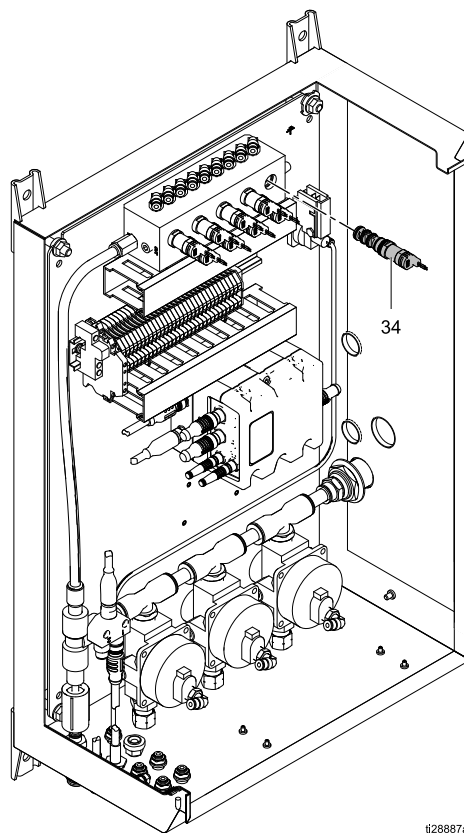

ti28887a

Manual Air Controller

Replace the Voltage to Pressure (V2P) Regulator

NOTE: This part is not used on Manual Air Controllers.

Follow these directions to replace the voltage to pressure regulator (41).

1. Follow directions at [Prepare for Service, page 24](#).
2. Remove the turbine air solenoid. See [Replace the Trigger or Auxiliary Solenoid Valve, page 27](#).
3. Disconnect the cable (44) and tube (50).
4. Remove screws (35) to remove the regulator assembly, including the bracket (40).
5. Remove screws (40a) to disconnect the regulator from the bracket.
6. Remove the elbows (10, 12), the muffler (61) and the reducer bushing (69).
7. Apply thread sealant to the threads on the elbows (10, 12) and the reducer bushing (69). Tighten them into the new regulator (41), along with the muffler (61).

8. Use screws (40a) to attach the new regulator (41) to the bracket.
9. Use screws (35) to attach the assembly to the controller box.
10. Reconnect the cable (44) and tube (50).
11. Reinstall the turbine air solenoid. See [Replace the Trigger or Auxiliary Solenoid Valve, page 27](#). Also see the calibration procedure on the System Logic Controller manual, 3A3955, in Initial *Setup/Calibration Screen*.

NOTE: For better accuracy, perform a “zero clear” as detailed in the instruction manual that is included with the V2P regulator. The unit should be powered on with no air applied.

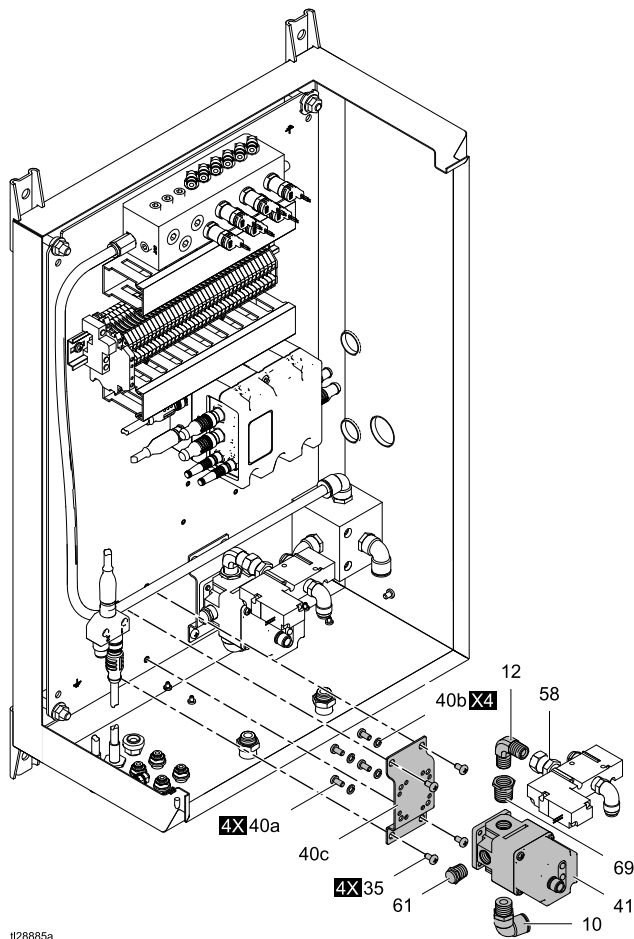

Replace a Shaping Air Solenoid Valve

NOTE: This part is not used on Manual Air Controllers.

Follow these directions to replace either the inner shaping air (SI) solenoid (57) or the outer shaping air (SO) solenoid (57).

1. See [Prepare for Service, page 24](#).
2. Disconnect the air tubing (49).
3. Disconnect the electrical wires. See the table for more information.

Table 13 Wire Connections, Solenoids 8 and 9

Solenoid	Terminal Blocks	
	Electronic Air Controller	Manual Air Controller
Inner Shaping Air	13 and 14	14 and 15
Outer Shaping Air	20 and 21	18 and 19

4. Loosen the swivel on the fitting (58). Remove the solenoid assembly.
5. Remove the fittings (58, 59) and muffler (61) from the solenoid (57).
6. Apply thread sealant to the threads on the fittings (58, 59). Tighten them into the new solenoid, along with the muffler (61).
7. Install the solenoid assembly and tighten the swivel on fitting (58).
8. Reconnect the wires. Connect the line power and the COM wire to the two terminal blocks listed. It doesn't matter which wire goes to which terminal. See the table.
9. Reconnect the air tubing (49).
10. Test the new solenoid using maintenance screens on the system logic controller. See manual 3A3955, System Logic Controller, for more information.

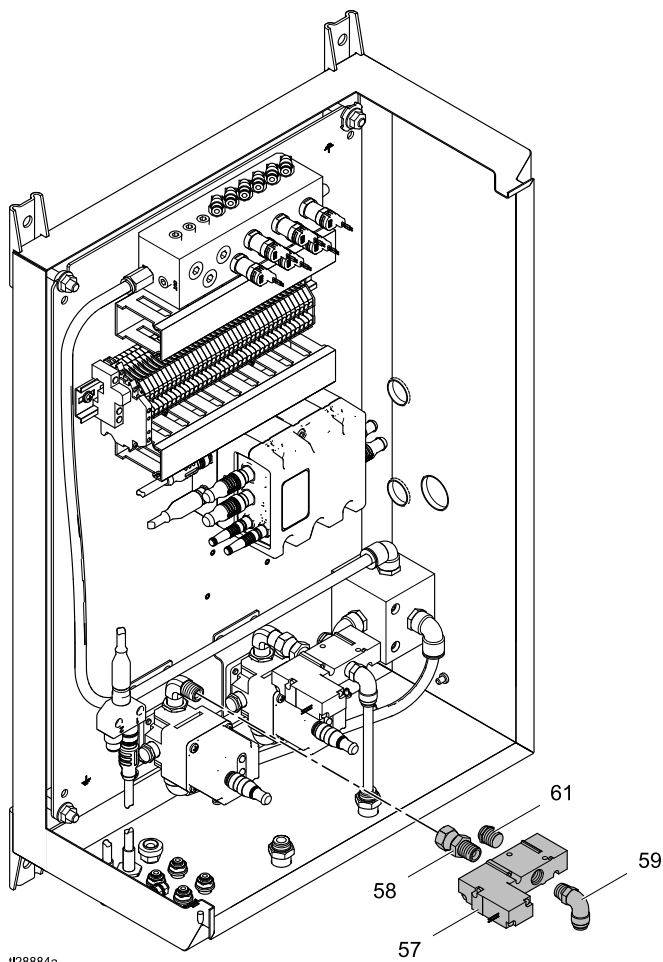

Replace the Pressure Switch

NOTE: This part is not used on Electronic Air Controllers.

Follow these directions to replace the pressure switch (101, Kit 26A292).

1. Follow directions at [Prepare for Service, page 24](#).
2. Disconnect the air tubing (26).
3. Disconnect the wires (110) from the pressure switch (101).
4. Remove two screws (96), then remove the pressure switch assembly.
5. Use screws (96) to attach the pressure switch assembly to the box.
6. Reconnect the wires (110).

Pressure Switch Wire	Terminal Block
COM	11
NO	12
NC	13

7. Reconnect the air tubing (26).

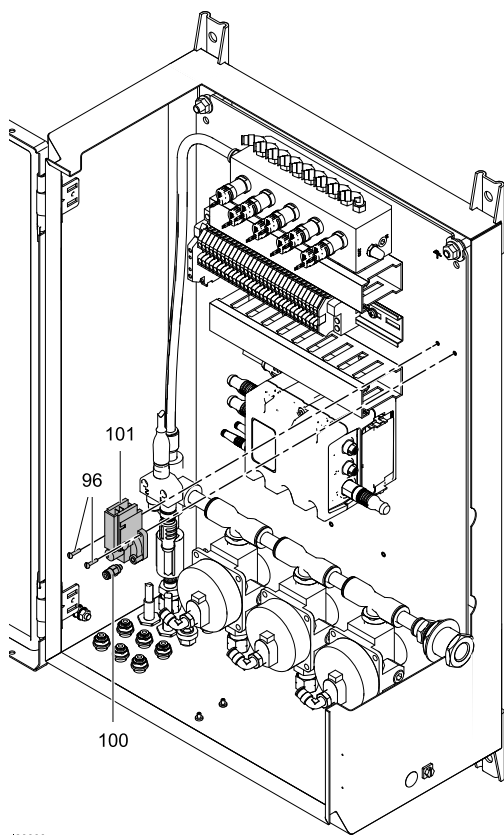

i28888a

Replace a Pressure Gauge

NOTE: This part is not used on Electronic Air Controllers.

Follow these directions to replace the pressure gauge (104)

1. Follow directions at [Prepare for Service, page 24](#).
2. Remove the air tubing (26).
3. Loosen the swivel on elbow (107).
4. Remove the nuts (104a and 40b) the bracket (104c) and the pressure gauge (104).
5. Install a new pressure gauge (104). Slide the bracket (104c) onto the gauge and secure with nuts (104a and 104b).
6. Tighten the swivel on the elbow (107).
7. Reconnect the air tubing (26).

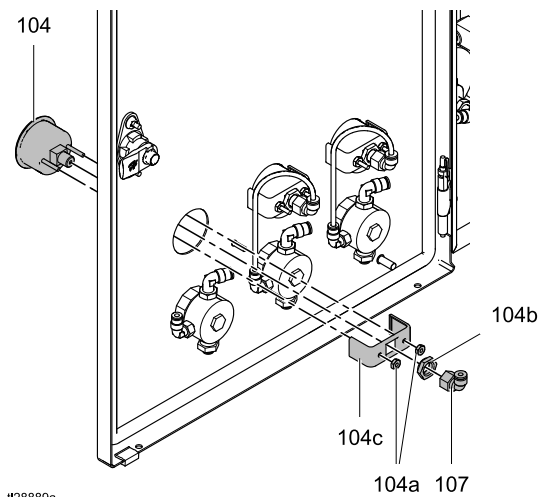

i28889a

Replace a Pressure Regulator

NOTE: This part is not used on Electronic Air Controllers.

Follow these directions to replace the pressure regulator (106).

1. Follow directions at [Prepare for Service, page 24](#).
2. Remove the air tubing (26).
3. Loosen the regulator nut (105) on the front of the box.
4. Remove the regulator assembly.
5. Remove the elbows (33, 99, and 107), pipe plug (39), and the connector (108).
6. Apply thread sealant to the threads on the elbows (33, 99, and 107) and the connector (108). Tighten them into the new regulator (106). Install the pipe plug (39).
7. Install the new regulator assembly and tighten the regulator nut (105).
8. Reconnect the air tubing (26).

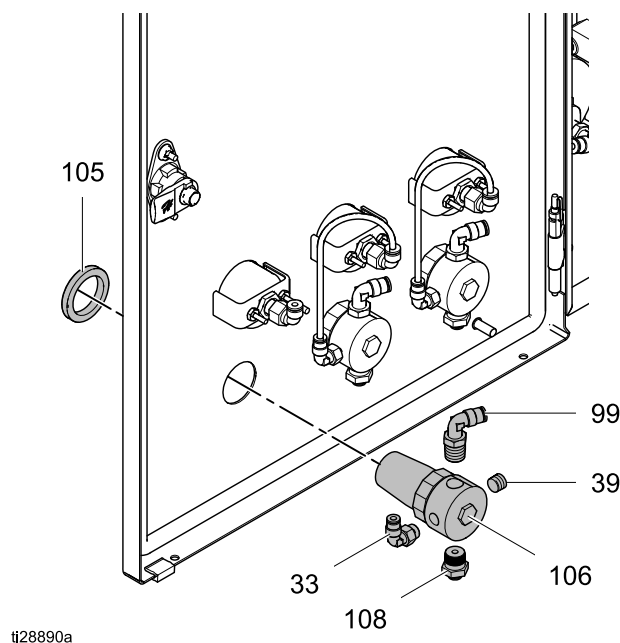

Replace the Bearing Air Filter

NOTE: This part is not used on Electronic Air Controllers.

Follow these directions to replace the bearing air filter (79).

1. Follow directions at [Prepare for Service, page 24](#).
2. Pull fitting (109) off of tee (103).
3. Leave tee and fitting (80) together and pull the assembly off of the filter (79).
4. Remove the filter (79) from fitting (81).

Note the flow direction arrow on the filter. The flow should go from the air manifold block to the bulkhead on the enclosure.
5. Install the new filter (79) on fitting (81).
6. Reattach the push-to-connect fitting (80) and the tee (103).
7. Reconnect fitting (109).

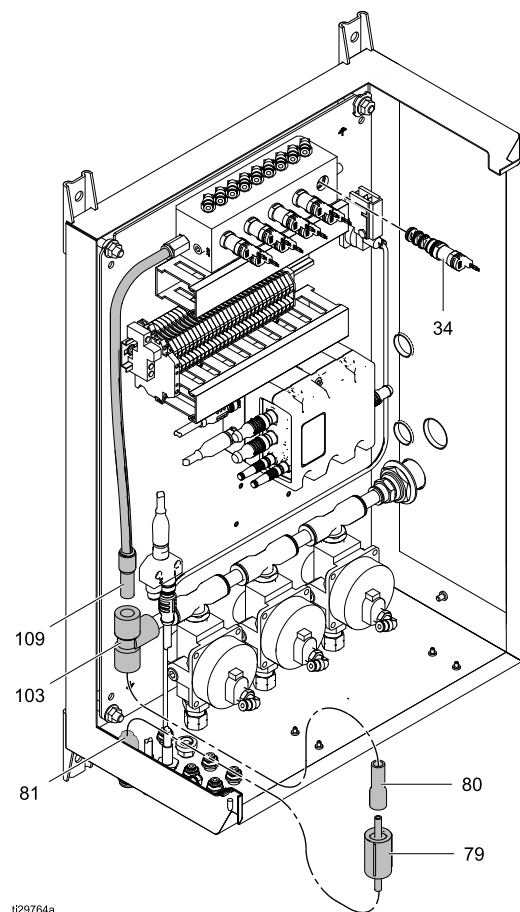

Parts

Electronic Air Controller (Model 24Z222)

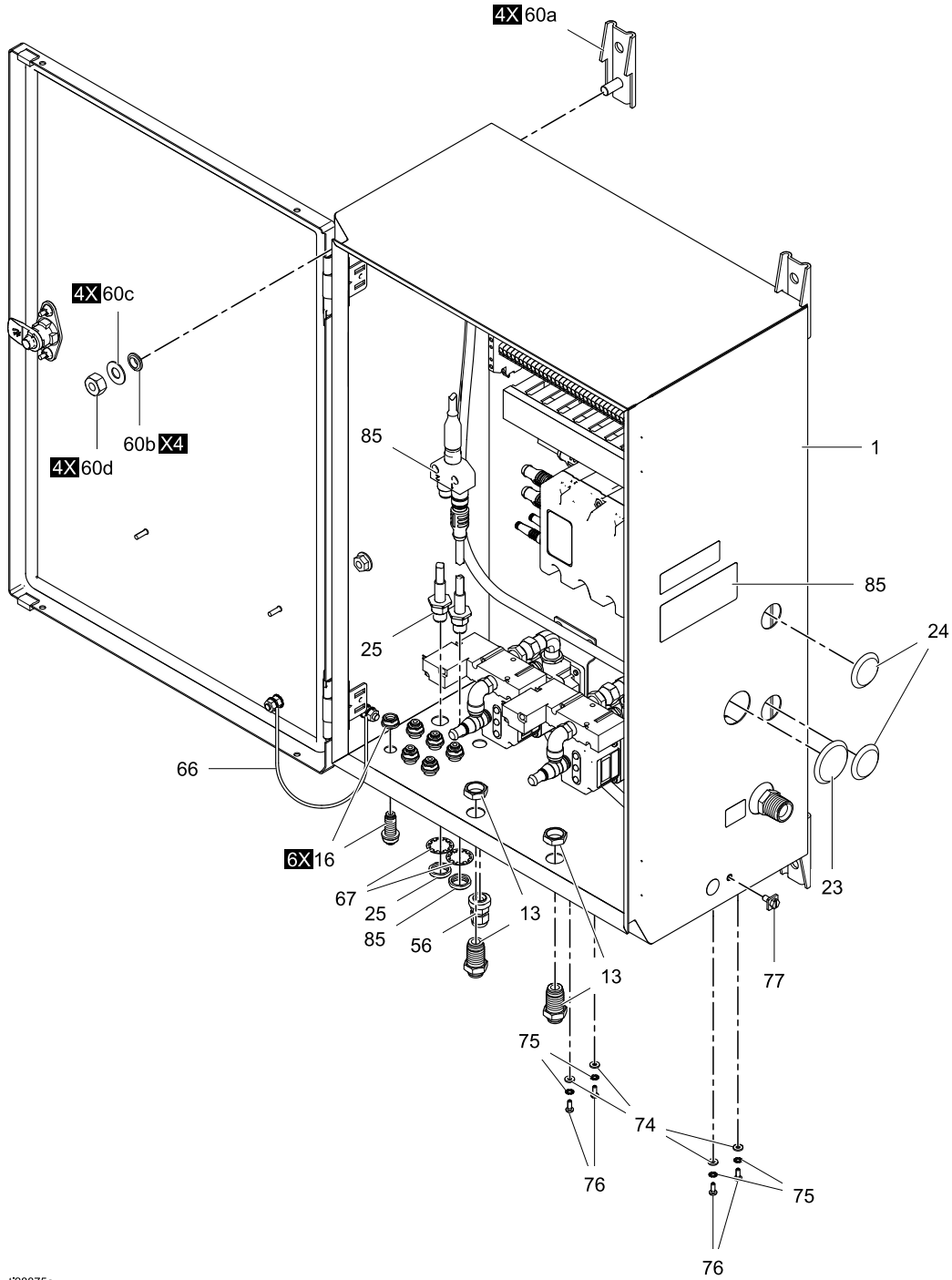

ti28875a

Electronic Air Controller (Model 24Z222)

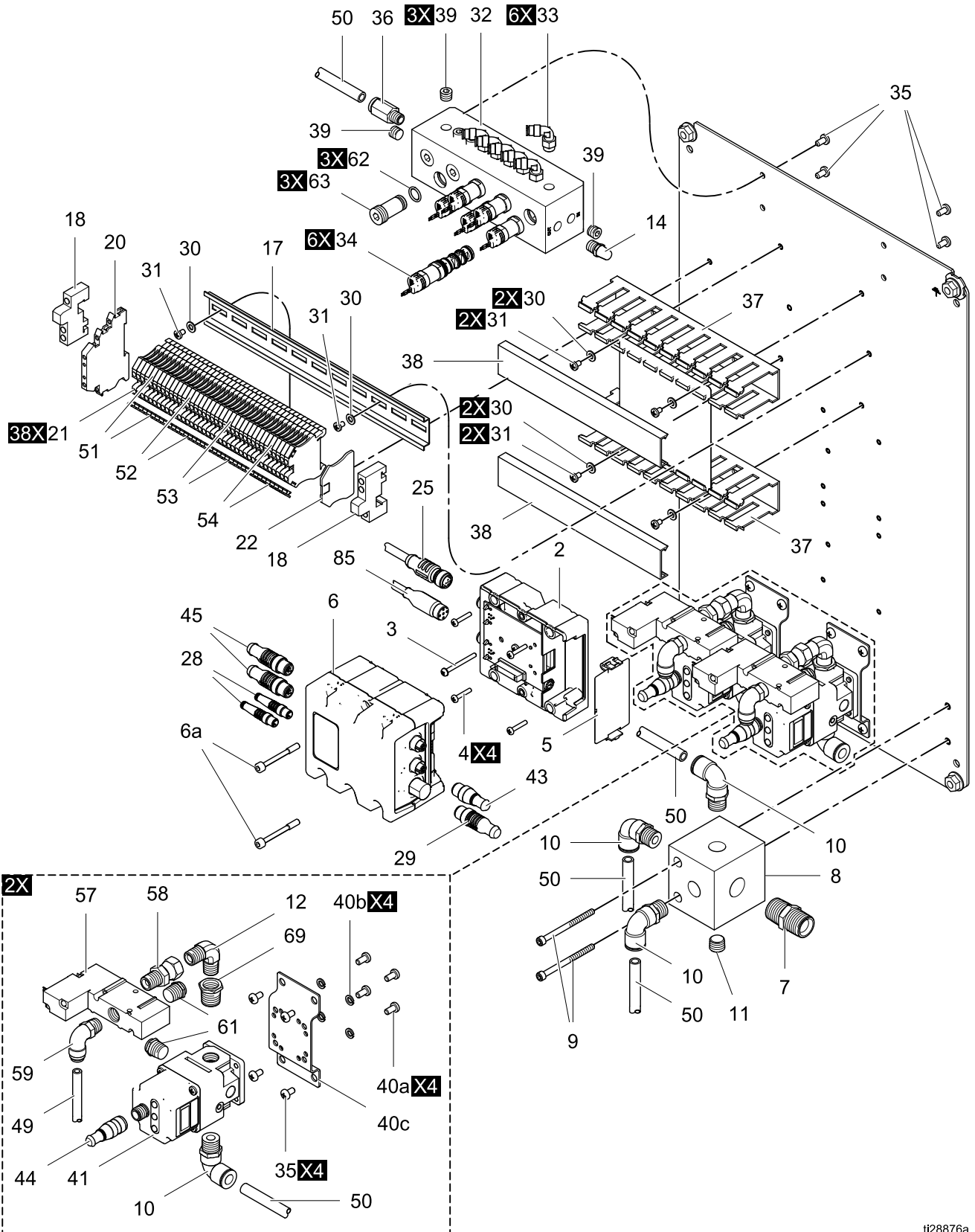

ti28876a

Parts

Ref	Part	Description	Qty
1	---	ENCLOSURE	1
2	289697	MODULE, base	1
3	---	SCREW, machine, pan head, 6-32 x 1 1/2 in.	1
4	---	SCREW, machine, pan head, 6-32 x 0.75 in.	4
5	277674	DOOR, cube	1
6	289696	MODULE, cube	1
7	158491	NIPPLE, 1/2-14 npt	1
8	---	MANIFOLD, air speed	1
9	514930	SCREW, cap, socket head, #10-32 x 2.5 in.	2
10	16F151	ELBOW, swivel, 3/8 T x 3/8 npt	5
11	100721	PLUG, pipe	1
12	110249	ELBOW, 90 degree, 1/4-18 npt	2
13	---	UNION, 5/16 Tube, bulkhead	2
14	C06061	MUFFLER, sintered, 1/8 dia	1
16	121818	UNION, 5/32 Tube	6
17	---	RAIL, mounting	1
18	112446	BLOCK, clamp end	2
20	24Z246	BLOCK, terminal, optocoupler	1
21	120491	BLOCK, terminal	38
22	120490	COVER, end	1
23	---	PLUG, button, 1 5/16 in.	1
24	---	PLUG, 1 in., round, plastic	2
25	---	CABLE, M12-5P	1
26	598095	TUBE, 5/32 OD	20 ft.
28	---	CABLE, M8-4P, 0.3 m	2
29	---	CABLE, M12-8P, 0.5 m	1
30	110874	WASHER, flat	6
31	112144	SCREW, machine, pan head, #8-32 x 0.25 in.	6
32	24T563	MANIFOLD, solenoid	1
33	114151	ELBOW, male, swivel, 5/32 T x 1/8 nptf	6
34	16P316	VALVE, solenoid	6
35	103833	SCREW, machine, cross recessed, pan head, #10-32 x 0.375 in.	12
36	108982	CONNECTOR, tube	1
37	---	DUCT, wire	1

Ref	Part	Description	Qty
38	---	COVER, wire duct	1
39	100139	PLUG, pipe	5
40	17D921	BRACKET, regulator	2
41	17G386	REGULATOR, electro/pneumatic, 3/8 npt	2
43	---	CABLE, M12-5P, 0.5 m	1
44	---	CABLE, M12-5P, 1.0 m	2
45	---	CABLE, M12-5P, 0.3 m	2
49	054776	TUBE, 5/16 OD	2 ft.
50	054134	TUBE, 3/8 OD	4 ft.
51	---	MARKER, terminal block, 1-10	2
52	---	MARKER, terminal block, 11-20	2
53	---	MARKER, terminal block, 21-30	2
54	---	MARKER, terminal block, 31-40	2
56	111987	CONNECTOR, strain relief	1
57	116463	VALVE, solenoid, 3-way	2
58	156823	UNION, swivel	2
59	115948	ELBOW, 1/4 npt x 5/16T	2
60	---	BRACKET, mounting, enclosure	1
61	112173	MUFFLER	4
62	---	O-RING, 13mm, light blue, included with Ref. 63	3
63	24T565	PLUG, manifold, includes o-ring (ref. 62)	3
66	---	WIRE, ground	1
67	101390	WASHER, lock	2
68	100272	WASHER, lock, #6	1
69	C19675	BUSHING, reducer	2
70	---	LABEL, port locations	1
74	151395	WASHER, flat	4
75	103181	WASHER, lock, ext.	4
76	100518	SCREW, machine, pan head, #6-32 x 0.375 in.	4
77	116343	SCREW, ground	1
78	172953	LABEL, grounding location	1
84▲	17K394	LABEL, warning	1
85	17E418	CABLE, splitter	1

▲ Replacement Danger and Warning labels, tags, and cards are available at no cost.

Manual Air Controller (Model 24Z221)

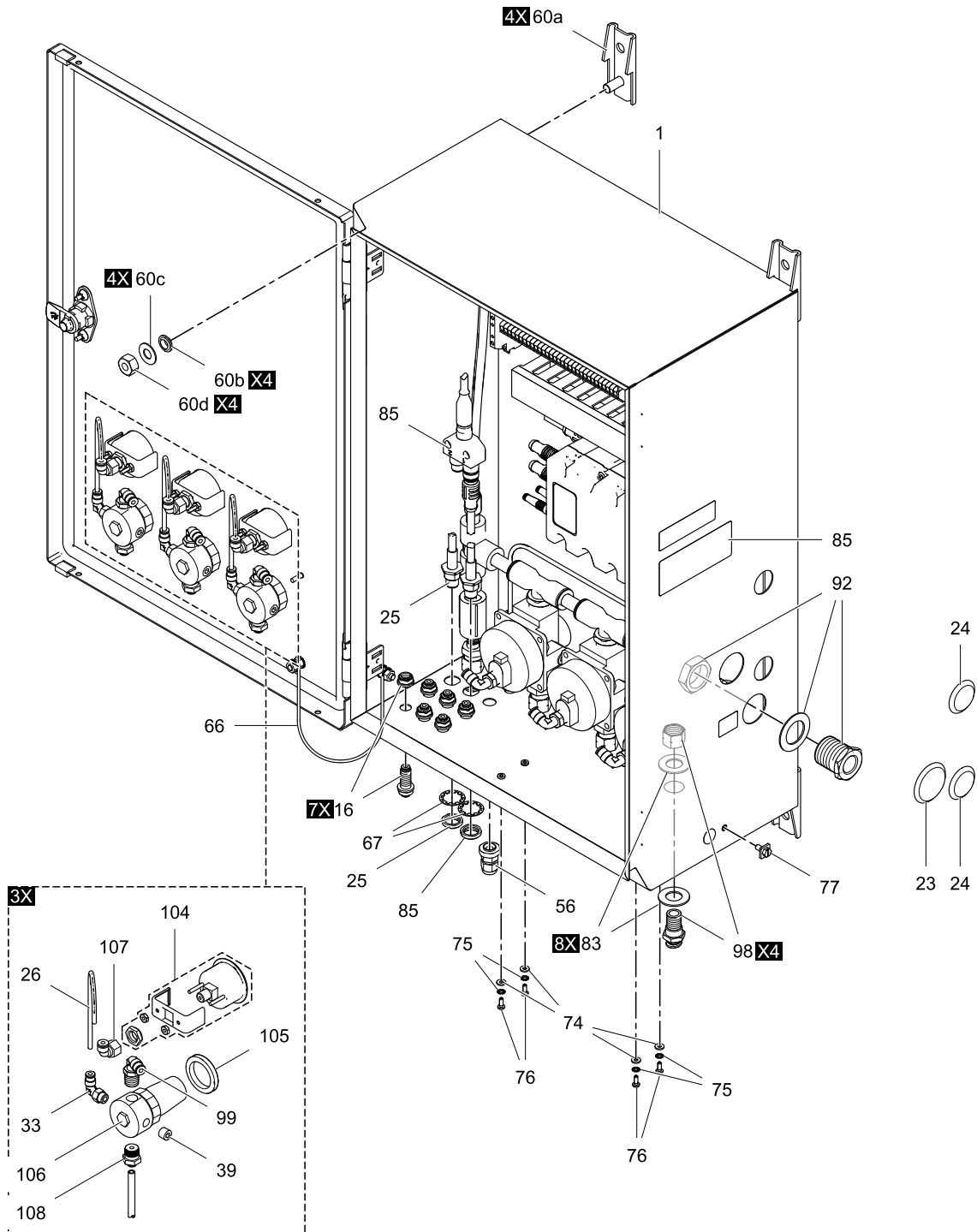

t28880a

Parts

Manual Air Controller (Model 24Z221)

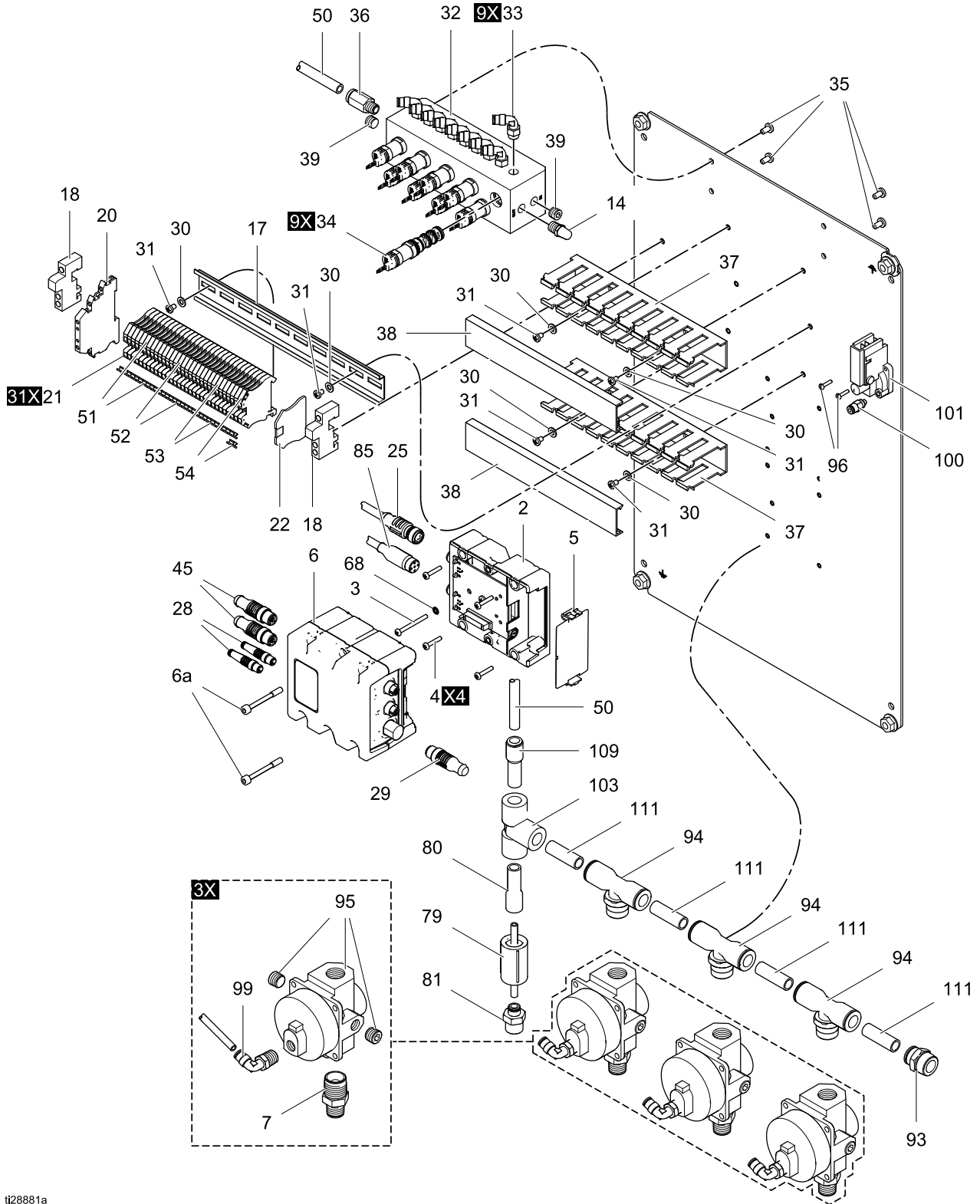

ti28881a

Ref	Part	Description	Qty
1	----	ENCLOSURE	1
2	289697	MODULE, base	1
3	----	SCREW, machine, pan head, 6-32 x 1 1/2 in.	1
4	----	SCREW, machine, pan head, 6-32 x 0.75 in.	4
5	277674	DOOR, cube	1
6	289696	MODULE, cube	1
7	159239	NIPPLE, pipe, 3/8-18 npt x 1/2-14 npt	3
14	C06061	MUFFLER, sintered, 1/8 dia	1
16	121818	UNION, 5/32 T	7
17	----	RAIL, mounting	1
18	112446	BLOCK, clamp end	2
20	24Z226	BLOCK, terminal, optocoupler	1
21	120491	BLOCK, terminal	31
22	120490	COVER, end	1
23	----	PLUG, button, 1 5/16	1
24	----	PLUG, 1 in., round, plastic	2
25	----	CABLE, M12-5P	2
26	598095	TUBE, 5/32 OD	28 ft.
28	----	CABLE, M8-4P, 0.3 m	2
29	----	CABLE, M12-8P, 0.5 m	1
30	110874	WASHER, flat	6
31	112144	SCREW, machine, pan head, #8-32 x 0.25 in.	6
32	24T563	MANIFOLD, solenoid	1
33	114151	ELBOW, male, swivel, 5/32 T x 1/8 nptf	12
34	16P316	VALVE, solenoid	9
35	103833	SCREW, machine, cross recessed, pan head, #10-32 x 0.375 in.	4
36	108982	CONNECTOR, 3/8 Tube, 90 degree,	1
37	----	DUCT, wire	1
38	----	COVER, wire duct	1
39	100139	PLUG, pipe	5
45	----	CABLE, M12-5P	2
50	054134	TUBE, 3/8 OD	1.5 ft.
51	----	MARKER, terminal block, 1-10	2
52	----	MARKER, terminal block, 11-20	2
53	----	MARKER, terminal block, 21-30	2

Ref	Part	Description	Qty
54	----	MARKER, terminal block, 31-40	2
56	111987	CONNECTOR, strain relief	1
60	----	BRACKET, mounting, enclosure	1
66	----	WIRE, ground	1
67	101390	WASHER, lock	2
68	100272	WASHER, lock, #6	1
70	----	LABEL, port locations	1
74	151395	WASHER, flat	4
75	103181	WASHER, lock, ext.	4
76	100518	SCREW, machine, pan head, #6-32 x 0.375 in.	4
77	116343	SCREW, ground	1
78	172953	LABEL, grounding location	1
79	17M754	FILTER, coalescing, miniature	1
80	17A244	FITTING, push to connect, 1/2 to 1/4 reducing	1
81	128798	FITTING, push to connect, 1/4 Tube x 3/8 npt(m)	1
83	154636	WASHER, flat	4
84▲	17K394	LABEL, warning	1
85	17E418	CABLE, splitter	1
92	512905	FITTING, brass	1
93	111411	CONNECTOR, 1/2T	1
94	----	TEE, 1/2-14 npt x 1/2 T OD	3
95	120435	REGULATOR, remote piloted	3
96	100171	SCREW, pan head, #4-40 x 0.5 in.	2
98	----	CONNECTOR, push-in, 5/16 T, 3/8 nptf	4
99	114469	ELBOW, swivel, 1/4 nptf	6
100	----	CONNECTOR, male, 10-32 UNF x 5/32 T	1
101	26A292	SWITCH, pressure, 70 psi, includes screws (Ref. 96) and connector (Ref. 100)	1
102	----	CONNECTOR, spade	3
103	513226	TEE, 1/2 in.	1
104	P00569	GAUGE, pressure, air	3
105	115244	NUT, regulator	3
106	110318	REGULATOR, air, 1/4 in. npt	3
107	15T498	ELBOW, 90 degree, swivel, 5/32T x 1/8 npt	3
108	15D916	CONNECTOR, 5/32 to 1/4 npt	3

Parts

Ref	Part	Description	Qty
109	— — —	FITTING, straight, 1/2 x 3/8 Tube	1
111	061513	TUBE, 1/2 OD	2 ft.

▲ Replacement Danger and Warning labels, tags, and cards are available at no cost.

Kits and Accessories

Power Supply Kit 24Z224

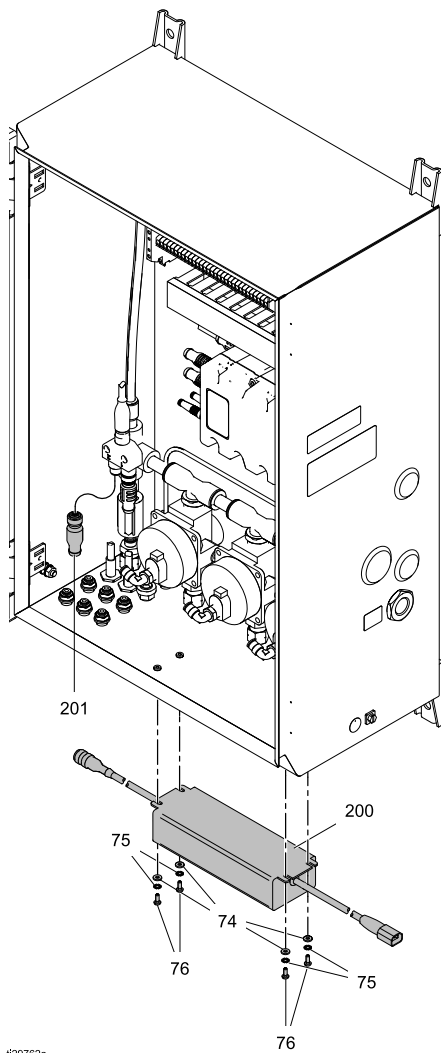

ti29762a

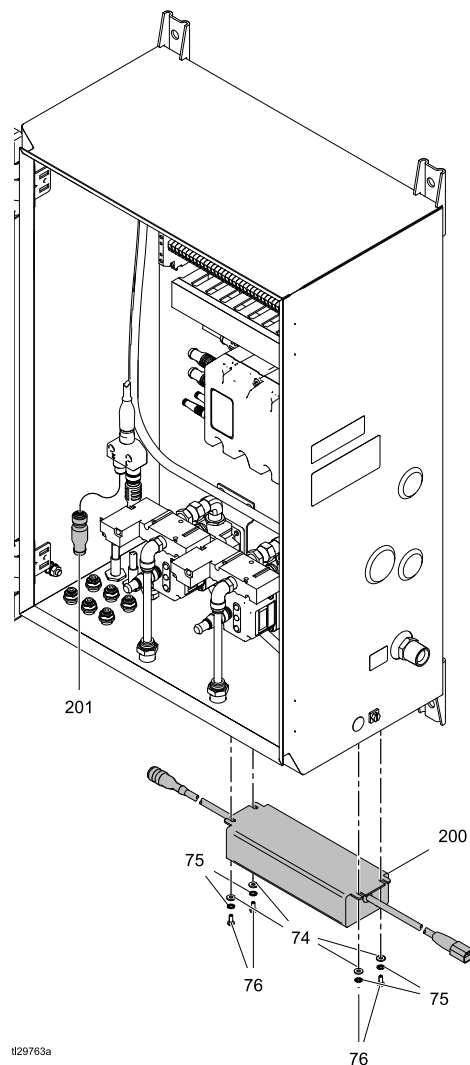

ti29763a

Ref.	Part	Description	Qty.
74	100518	WASHER, flat	4
75	103181	WASHER, lock	4
76	141395	SCREW, machine, pan head, #6-32 x 0.375 in.	4
201	120999	RESISTOR, termination	1
200	---	POWER SUPPLY	1
---	245202	CORDSET, USA, 10 ft. (3 m) 13A, 120V; not shown	1

System Logic Controller Kit 24Z223

Part	Description	Qty.
— — —	MODULE, System Logic Controller	1
17M465	TOKEN, software upgrade	1

Graco CAN Cables

Part	Length
130193	0.5 m (1.6 ft.)
121001	1 m (3.3 ft.)
121002	1.5 m (4.9 ft.)
121003	3 m (9.8 ft.)

Communication Gateway Kits

Part	Description
CGMDN0	DeviceNet
CGMEP0	EhterNet IP
24W462	Modbus TCP
CGMPN0	PROFINET

ProBell Gateway Installation Kit 24Z574

Part	Description	Qty
— — —	TOKEN, programming	1
130193	CABLE, CAN, 0.5 m	1
121901	SUPPRESSOR	2
— — —	SCREW, machine, 6–32 x 1–1/2	1
100272	WASHER, lock, #6	1
— — —	SCREW, #6–32 x 0.75 in.	4
— — —	GROMMET, bulkhead, cable entry	1

Optocoupler Kit 24Z246

Part	Description	Qty
— — —	Block, terminal, optocoupler	1

ProBell Token Programming Kit 17M465

System Logic Controller Screen Protector 15V511

Technical Specifications

ProBell Air Controller		
	US	Metric
Maximum air working pressure	100 psi	0.69 MPa, 7.0 bar
Turbine speed, maximum operating	60,000 rpm	
Bearing air, minimum required	70 psi	0.5 MPa, 5.0 bar
Air Connection	1/2" npt	
Maximum Operating Voltage	24 VDC, 2.5A	
Operating Temperature Range	32° to 122° F	0° to 50° C
Power connection for part 24Z224	Straight IEC 320-C13 male connector and a North American NEMA 5-15P ISP male plug are provided.	
External Power Requirements for part 24Z224	100-240 VAC, 50/60 Hz, 2A maximum draw, 15 amp circuit breaker recommended	
Storage Temperature Range	-22° to 140° F	-30° to 60° C
Weight	47.5 lb.	21.5 kg.

Graco Standard Warranty

Graco warrants all equipment referenced in this document which is manufactured by Graco and bearing its name to be free from defects in material and workmanship on the date of sale to the original purchaser for use. With the exception of any special, extended, or limited warranty published by Graco, Graco will, for a period of twelve months from the date of sale, repair or replace any part of the equipment determined by Graco to be defective. This warranty applies only when the equipment is installed, operated and maintained in accordance with Graco's written recommendations.

This warranty does not cover, and Graco shall not be liable for general wear and tear, or any malfunction, damage or wear caused by faulty installation, misapplication, abrasion, corrosion, inadequate or improper maintenance, negligence, accident, tampering, or substitution of non-Graco component parts. Nor shall Graco be liable for malfunction, damage or wear caused by the incompatibility of Graco equipment with structures, accessories, equipment or materials not supplied by Graco, or the improper design, manufacture, installation, operation or maintenance of structures, accessories, equipment or materials not supplied by Graco.

This warranty is conditioned upon the prepaid return of the equipment claimed to be defective to an authorized Graco distributor for verification of the claimed defect. If the claimed defect is verified, Graco will repair or replace free of charge any defective parts. The equipment will be returned to the original purchaser transportation prepaid. If inspection of the equipment does not disclose any defect in material or workmanship, repairs will be made at a reasonable charge, which charges may include the costs of parts, labor, and transportation.

THIS WARRANTY IS EXCLUSIVE, AND IS IN LIEU OF ANY OTHER WARRANTIES, EXPRESS OR IMPLIED, INCLUDING BUT NOT LIMITED TO WARRANTY OF MERCHANTABILITY OR WARRANTY OF FITNESS FOR A PARTICULAR PURPOSE.

Graco's sole obligation and buyer's sole remedy for any breach of warranty shall be as set forth above. The buyer agrees that no other remedy (including, but not limited to, incidental or consequential damages for lost profits, lost sales, injury to person or property, or any other incidental or consequential loss) shall be available. Any action for breach of warranty must be brought within two (2) years of the date of sale.

GRACO MAKES NO WARRANTY, AND DISCLAIMS ALL IMPLIED WARRANTIES OF MERCHANTABILITY AND FITNESS FOR A PARTICULAR PURPOSE, IN CONNECTION WITH ACCESSORIES, EQUIPMENT, MATERIALS OR COMPONENTS SOLD BUT NOT MANUFACTURED BY GRACO. These items sold, but not manufactured by Graco (such as electric motors, switches, hose, etc.), are subject to the warranty, if any, of their manufacturer. Graco will provide purchaser with reasonable assistance in making any claim for breach of these warranties.

In no event will Graco be liable for indirect, incidental, special or consequential damages resulting from Graco supplying equipment hereunder, or the furnishing, performance, or use of any products or other goods sold hereto, whether due to a breach of contract, breach of warranty, the negligence of Graco, or otherwise.

FOR GRACO CANADA CUSTOMERS

The Parties acknowledge that they have required that the present document, as well as all documents, notices and legal proceedings entered into, given or instituted pursuant hereto or relating directly or indirectly hereto, be drawn up in English. Les parties reconnaissent avoir convenu que la rédaction du présente document sera en Anglais, ainsi que tous documents, avis et procédures judiciaires exécutés, donnés ou intentés, à la suite de ou en rapport, directement ou indirectement, avec les procédures concernées.

Graco Information

For the latest information about Graco products, visit www.graco.com. For patent information, see www.graco.com/patents.

To place an order, contact your Graco Distributor or call to identify the nearest distributor.
Phone: 612-623-6921 or **Toll Free:** 1-800-328-0211 **Fax:** 612-378-3505

All written and visual data contained in this document reflects the latest product information available at the time of publication.
Graco reserves the right to make changes at any time without notice.
Original Instructions. This manual contains English, MM 3A3657

Graco Headquarters: Minneapolis
International Offices: Belgium, China, Japan, Korea

GRACO INC. AND SUBSIDIARIES • P.O. BOX 1441 • MINNEAPOLIS, MN 55440-1441 • USA

Copyright 2016, Graco Inc. All Graco manufacturing locations are registered to ISO 9001.

www.graco.com
Revision C, September 2017