



## Husky™ 1050e Electric Diaphragm Pump

334189G  
EN

1-Inch pumps with electric drive for fluid transfer applications. For professional use only.



### Important Safety Instructions

Read all warnings and instructions in this manual and in your Husky 1050e Operation manual. **Save these instructions.**

*For maximum operating pressures, see the Performance Charts on pages 51–54 in the Operation manual.  
See pages 6–7 for model information, including approvals.*

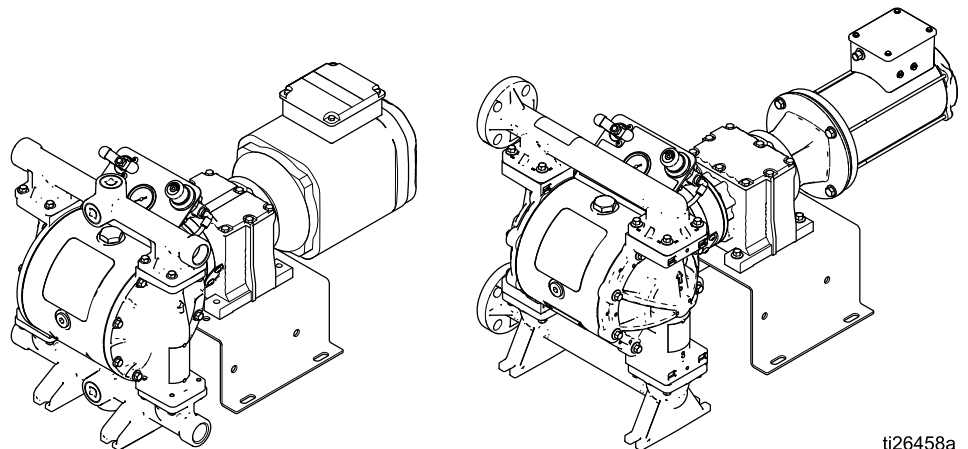

ti26458a

# Contents

Related Manuals .....	2	Center Section Repair .....	17
Warnings .....	3	Disconnect the Motor and Gearbox .....	22
Configuration Number Matrix .....	6	Replace the Compressor .....	23
Ordering Information .....	8	Torque Instructions .....	24
Overview .....	9	Parts .....	26
Troubleshooting .....	10	Cart .....	37
Repair .....	12	Kits and Accessories .....	40
Pressure Relief Procedure .....	12	Technical Data .....	41
Check Valve Repair .....	12	Graco Standard Warranty .....	46
Diaphragm Repair .....	14		







## Related Manuals







Manual Number	Title
334188	Husky 1050E Electric Double Diaphragm Pump, Operation

# Warnings

The following warnings are for the setup, use, grounding, maintenance, and repair of this equipment. The exclamation point symbol alerts you to a general warning and the hazard symbols refer to procedure-specific risks. When these symbols appear in the body of this manual or on warning labels, refer back to these Warnings. Product-specific hazard symbols and warnings not covered in this section may appear throughout the body of this manual where applicable.

 <h1 style="margin: 0;">WARNING</h1>	
	<p><b>ELECTRIC SHOCK HAZARD</b></p> <p>This equipment must be grounded. Improper grounding, setup, or usage of the system can cause electric shock.</p> <ul style="list-style-type: none"> <li>• Turn off and remove power before disconnecting any cables and before servicing or installing equipment. For cart-mounted models, unplug the power cord. For all other units, disconnect power at the main switch.</li> <li>• Connect only to grounded power source.</li> <li>• All electrical wiring must be done by a qualified electrician and comply with all local codes and regulations.</li> <li>• Wait five minutes for capacitor discharge before opening equipment.</li> <li>• For cart-mounted models, use only 3-wire extension cords.</li> <li>• For cart-mounted models, ensure ground prongs are intact on any power and extension cords.</li> <li>• For cart-mounted models, do not expose to rain. Store indoors.</li> </ul>
	<p><b>FIRE AND EXPLOSION HAZARD</b></p> <p>Flammable fumes, such as solvent and paint fumes, in <b>work area</b> can ignite or explode. Paint or solvent flowing through the equipment can cause static sparking. To help prevent fire and explosion:</p> <ul style="list-style-type: none"> <li>• Use equipment only in well ventilated area.</li> <li>• Eliminate all ignition sources; such as pilot lights, cigarettes, portable electric lamps, and plastic drop cloths (potential static arc).</li> <li>• Ground all equipment in the work area. See <b>Grounding</b> instructions.</li> <li>• Keep work area free of debris, including solvent, rags and gasoline.</li> <li>• Do not plug or unplug power cords, or turn power or light switches on or off when flammable fumes are present.</li> <li>• Use only grounded hoses.</li> <li>• <b>Stop operation immediately</b> if static sparking occurs or you feel a shock. Do not use equipment until you identify and correct the problem.</li> <li>• Keep a working fire extinguisher in the work area.</li> </ul> <p>Static charge may build up on plastic parts during cleaning and could discharge and ignite flammable vapors. To help prevent fire and explosion:</p> <ul style="list-style-type: none"> <li>• Clean plastic parts only in well ventilated area.</li> <li>• Do not clean with a dry cloth.</li> <li>• Do not operate electrostatic guns in equipment work area.</li> </ul>

 <h1 style="margin: 0;">WARNING</h1>	
 	<p><b>PRESSURIZED EQUIPMENT HAZARD</b></p> <p>Fluid from the equipment, leaks, or ruptured components can splash in the eyes or on skin and cause serious injury.</p> <ul style="list-style-type: none"> <li>Follow the <b>Pressure Relief Procedure</b> when you stop spraying/dispensing and before cleaning, checking, or servicing equipment.</li> <li>Tighten all fluid connections before operating the equipment.</li> <li>Check hoses, tubes, and couplings daily. Replace worn or damaged parts immediately.</li> </ul>
 	<p><b>EQUIPMENT MISUSE HAZARD</b></p> <p>Misuse can cause death or serious injury.</p> <ul style="list-style-type: none"> <li>Do not operate the unit when fatigued or under the influence of drugs or alcohol.</li> <li>Do not exceed the maximum working pressure or temperature rating of the lowest rated system component. See <b>Technical Data</b> in all equipment manuals.</li> <li>Use fluids and solvents that are compatible with equipment wetted parts. See <b>Technical Data</b> in all equipment manuals. Read fluid and solvent manufacturer's warnings. For complete information about your material, request Safety Data Sheet (SDS) from distributor or retailer.</li> <li>Turn off all equipment and follow the <b>Pressure Relief Procedure</b> when equipment is not in use.</li> <li>Check equipment daily. Repair or replace worn or damaged parts immediately with genuine manufacturer's replacement parts only.</li> <li>Do not alter or modify equipment. Alterations or modifications may void agency approvals and create safety hazards.</li> <li>Make sure all equipment is rated and approved for the environment in which you are using it.</li> <li>Use equipment only for its intended purpose. Call your distributor for information.</li> <li>Route hoses and cables away from traffic areas, sharp edges, moving parts, and hot surfaces.</li> <li>Do not kink or over bend hoses or use hoses to pull equipment.</li> <li>Keep children and animals away from work area.</li> <li>Comply with all applicable safety regulations.</li> </ul>
	<p><b>PRESSURIZED ALUMINUM PARTS HAZARD</b></p> <p>Use of fluids that are incompatible with aluminum in pressurized equipment can cause serious chemical reaction and equipment rupture. Failure to follow this warning can result in death, serious injury, or property damage.</p> <ul style="list-style-type: none"> <li>Do not use 1,1,1-trichloroethane, methylene chloride, other halogenated hydrocarbon solvents or fluids containing such solvents.</li> <li>Do not use chlorine bleach.</li> <li>Many other fluids may contain chemicals that can react with aluminum. Contact your material supplier for compatibility.</li> </ul>

 <h1 style="margin: 0;">WARNING</h1>	
	<p><b>THERMAL EXPANSION HAZARD</b></p> <p>Fluids subjected to heat in confined spaces, including hoses, can create a rapid rise in pressure due to the thermal expansion. Over-pressurization can result in equipment rupture and serious injury.</p> <ul style="list-style-type: none"> <li>• Open a valve to relieve the fluid expansion during heating.</li> <li>• Replace hoses proactively at regular intervals based on your operating conditions.</li> </ul>
	<p><b>PLASTIC PARTS CLEANING SOLVENT HAZARD</b></p> <p>Many solvents can degrade plastic parts and cause them to fail, which could cause serious injury or property damage.</p> <ul style="list-style-type: none"> <li>• Use only compatible water-based solvents to clean plastic structural or pressure-containing parts.</li> <li>• See <b>Technical Data</b> in this and all other equipment instruction manuals. Read fluid and solvent manufacturer's Safety Data Sheet (SDS) and recommendations.</li> </ul>
	<p><b>TOXIC FLUID OR FUMES HAZARD</b></p> <p>Toxic fluids or fumes can cause serious injury or death if splashed in the eyes or on skin, inhaled, or swallowed.</p> <ul style="list-style-type: none"> <li>• Read Safety Data Sheet (SDS) to know the specific hazards of the fluids you are using.</li> <li>• Store hazardous fluid in approved containers, and dispose of it according to applicable guidelines.</li> </ul>
	<p><b>BURN HAZARD</b></p> <p>Equipment surfaces and fluid that's heated can become very hot during operation. To avoid severe burns:</p> <ul style="list-style-type: none"> <li>• Do not touch hot fluid or equipment.</li> </ul>
	<p><b>PERSONAL PROTECTIVE EQUIPMENT</b></p> <p>Wear appropriate protective equipment when in the work area to help prevent serious injury, including eye injury, hearing loss, inhalation of toxic fumes, and burns. This protective equipment includes but is not limited to:</p> <ul style="list-style-type: none"> <li>• Protective eyewear, and hearing protection.</li> <li>• Respirators, protective clothing, and gloves as recommended by the fluid and solvent manufacturer.</li> </ul>

# Configuration Number Matrix

Check the identification plate (ID) for the Configuration Number of your pump. Use the following matrix to define the components of your pump.

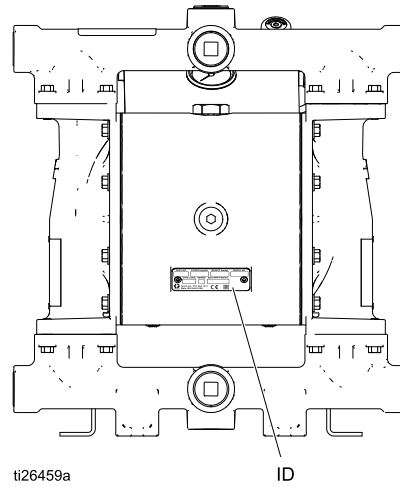





Sample Configuration Number: **1050A-E,A04AA1SSBNBNPT**

<b>1050</b>	<b>A</b>	<b>E</b>	<b>A</b>	<b>04A</b>	<b>A1</b>	<b>SS</b>	<b>BN</b>	<b>BN</b>	<b>PT</b>
Pump Model	Wetted Section Material	Drive	Center Section Material	Gear Box and Motor	Fluid Covers and Manifolds	Seats	Balls	Diaphragms	Manifold O-Rings

Pump	Wetted Section Material		Drive Type		Center Section Material		Motor and Gearbox	
	<b>1050</b>	<b>A</b>	Aluminum	<b>E</b>	Electric	<b>A</b>	Aluminum	<b>04A</b>
	<b>C</b>	Conductive Polypropylene			<b>S</b>	Stainless Steel	<b>04B</b>	Brushless DC Motor
	<b>F</b>	PVDF					<b>04C</b>	AC Induction Motor, ATEX◆
	<b>H</b>	Hastelloy					<b>04D</b>	Explosionproof AC Induction Motor ★
	<b>P</b>	Polypropylene					<b>04E</b>	NEMA 56 C Gearbox †
	<b>S</b>	Stainless Steel					<b>04F</b>	IEC 90 B5 Flange Gearbox †
							<b>05A</b>	Standard AC Induction Motor with Compressor (120V)
							<b>05B</b>	Brushless DC Motor with Compressor (120V)
							<b>06A</b>	Standard AC Induction Motor with Compressor (240V)
							<b>06B</b>	Brushless DC Motor with Compressor (240V)

Configuration Number Matrix

Fluid Covers and Manifolds		Seat Material		Ball Material		Diaphragm Material		Manifold O-Rings	
<b>A1</b>	Aluminum, npt	<b>AC</b>	Acetal	<b>AC</b>	Acetal	<b>BN</b>	Buna-N	--	Models with BN, FK, or TP seats do not use o-rings
<b>A2</b>	Aluminum, bsp	<b>AL</b>	Aluminum	<b>BN</b>	Buna-N	<b>CO</b>	Polychloroprene Overmold		
<b>C1</b>	Conductive polypropylene, center flange	<b>BN</b>	Buna-N	<b>CR</b>	Polychloroprene Standard	<b>FK</b>	FKM Fluoroelastomer	<b>PT</b>	PTFE
<b>C2</b>	Conductive polypropylene, end flange	<b>FK</b>	FKM Fluoroelastomer	<b>CW</b>	Polychloroprene Weighted	<b>GE</b>	Geolast		
<b>F1</b>	PVDF, center flange	<b>GE</b>	Geolast	<b>FK</b>	FKM Fluoroelastomer	<b>PO</b>	PTFE/EPDM Overmold		
<b>F2</b>	PVDF, end flange	<b>PP</b>	Polypropylene	<b>GE</b>	Geolast	<b>PT</b>	PTFE/EPDM 2-Piece		
<b>H1</b>	Hastelloy, npt	<b>PV</b>	PVDF	<b>PT</b>	PTFE	<b>PS</b>	PTFE/Santoprene 2-Piece		
<b>H2</b>	Hastelloy, bsp	<b>SP</b>	Santoprene	<b>SP</b>	Santoprene	<b>SP</b>	Santoprene		
<b>P1</b>	Polypropylene, center flange	<b>SS</b>	316 Stainless Steel	<b>SS</b>	316 Stainless Steel	<b>TP</b>	TPE		
<b>P2</b>	Polypropylene, end flange	<b>TP</b>	TPE	<b>TP</b>	TPE				
<b>S1</b>	Stainless steel, npt								
<b>S2</b>	Stainless steel, bsp								

Approvals	
<p>◆ Aluminum, conductive polypropylene, hastelloy, and stainless steel pumps with code <b>04C</b> are certified to:</p>	 II 2 G ck Ex d IIB T3 Gb
<p>✦ Aluminum, conductive polypropylene, hastelloy, and stainless steel pumps with code <b>04E</b> or <b>04F</b> are certified to:</p>	 II 2 G ck IIB T3 Gb
<p>★ Motors coded <b>04D</b> are certified to:</p>	 LISTED Class1, Zone 1, AEx d IIB T3 0°C<Ta<40°C 
<p>All Models (except <b>04D</b>, <b>05A</b>, and <b>05B</b>) are certified to:</p>	

## Ordering Information

### To Find Your Nearest Distributor

1. Visit [www.graco.com](http://www.graco.com).
2. Click on **Where to Buy** and use the **Distributor Locator**.

### To Specify the Configuration of a New Pump

Please call your distributor.

OR

Use the **Online Diaphragm Pump Selector Tool** at [www.graco.com](http://www.graco.com). Go to the **Process Equipment Page**.

### To Order Replacement Parts

Please call your distributor.



# Overview

The Husky 1050e product line offers electric-powered diaphragm pumps in a wide range of models. Use the selector tool at [www.graco.com](http://www.graco.com) to configure a pump to meet your needs. This section shows the basic structure of available models. Fluid section options

are too numerous to include. The many manifold, seat, ball, and diaphragm options are available on a wide variety of these models.

Center Section	Motor Type	Controller	Gearbox	Compressor	Approval Options	Cart	
Aluminum or Stainless Steel	AC	VFD — not included. VFD Kits 16K911 (240V) and 16K912 (480V) are available.	Yes, part of motor	Yes-120V	None	No*	
				Yes-240V	CE	No*	
				No		No*	
			IEC	No	ATEX and CE	No*	
	NEMA	No	Explosionproof	No*			
	Brush-less DC	Graco Motor Control — included	NEMA	Yes-120V	None	Yes	
				Yes-240V	CE	Yes	
				No		No*	
	None	None		NEMA	No	CE	No*
				IEC	No		No*

\* Cart Mounting Kit 24Y543 is available.

### Key Points:

- Pumps are available with an AC or Brushless DC (BLDC) motor, or with just a gearbox (for applications where a motor already is available).
- Graco recommends the use of a motor soft starter or a VFD (PN 16K911 or 16K912) in the electrical circuit for all installations. See the motor manufacturer’s recommendations for proper installation when using either of these components. In all cases, make sure all products are installed in accordance with local codes and regulations.
- BLDC motors are controlled by the Graco Motor Control that is supplied with the pump.
- The standard AC motor (not ATEX or Explosionproof) and the BLDC motor are available in models without a compressor, with a 120V compressor, or with a 240V compressor.
- The BLDC motor is available in models that are cart mounted. Cart Mounting Kit 24Y543 is available for other models.

# Troubleshooting



- Follow the [Pressure Relief Procedure, page 12](#), before checking or servicing the equipment.
- Check all possible problems and causes before disassembly.

See the Operation Manual (334188) for troubleshooting or error information on the Graco Motor Control.

Problem	Cause	Solution
Pump cycles but will not prime and/or pump.	Pump is running too fast, causing cavitation before prime.	Slow down the motor controller (VFD or Graco Motor Control)
	Center section has no air pressure, or air pressure is too low.	Apply air pressure to center section per your application requirements.
	Check valve ball is severely worn or wedged in seat or manifold.	Replace the ball and seat.
	The pump has insufficient suction pressure.	Increase the suction pressure. See the Operation manual.
	Seat is severely worn.	Replace the ball and seat.
	Outlet or inlet is restricted.	Remove the restriction.
	Inlet fittings or manifolds are loose.	Tighten.
The center section is excessively hot.	Manifold o-rings are damaged.	Replace o-rings.
	The drive shaft is broken.	Replace.
Pump fails to hold fluid pressure at stall.	Check valve balls, seats, or o-rings are worn.	Replace.
	Manifold screws or fluid cover screws are loose.	Tighten.
	Diaphragm shaft bolt is loose	Tighten.
Pump will not cycle.	Motor or controller is wired improperly.	Wire per manual.
	The leak detector (if installed) has tripped.	Check diaphragm for rupture or incorrect installation. Repair or replace.
The motor is operating, but the pump will not cycle.	The jaw coupling between the motor and gearbox is not connected properly.	Check the connection.
Pump flow rate is erratic.	Suction line is clogged.	Inspect; clear.
	Check balls are sticky or leaking .	Clean or replace.
	Diaphragm (or backup) ruptured.	Replace.
Pump makes unusual noises.	Pump is operating near or at stall pressure.	Adjust air pressure or slow the pump speed.

Problem	Cause	Solution
Air consumption is higher than expected.	A fitting is loose.	Tighten. Inspect thread sealant.
	Loose or damaged o-rings or shaft seal.	Replace.
	Diaphragm (or backup) ruptured.	Replace.
Air bubbles in fluid.	Suction line is loose.	Tighten.
	Diaphragm (or backup) ruptured.	Replace.
	Loose manifolds, damaged seats or o-rings.	Tighten manifold bolts or replace seats or o-rings.
	Loose diaphragm shaft bolt.	Tighten.
Pump leaks fluid externally from joints.	Loose manifold screws or fluid cover screws.	Tighten.
	Manifold o-rings worn out.	Replace o-rings.
The controller faults or shuts down.	A GFCI has tripped.	Remove the controller from the GFCI circuit.
	Supply power is poor.	Determine and fix the source of the power problem.
	Operational parameters are exceeded.	See Operation manual for event codes and controller troubleshooting.
<p><b>NOTE:</b> For problems with a Variable Frequency Device (VFD), see your VFD manual. For problems with the Graco Motor Control, see your 1050e Operation Manual.</p>		

# Repair

## Pressure Relief Procedure



Follow the Pressure Relief Procedure whenever you see this symbol.

<p>This equipment stays pressurized until pressure is relieved manually. To help prevent serious injury from pressurized fluid, such as splashing in the eyes or on skin, follow the Pressure Relief Procedure when you stop pumping and before you clean, check, or service the equipment.</p>				

**NOTE:** For split manifold units, perform pressure relief procedure for both sides of the pump.

1. Remove power from the system.
2. Open the dispensing valve, if used.
3. Open the fluid drain valve (L) to relieve fluid pressure. Have a container ready to catch the drainage.
4. Close the pump air valve.
5. **Units with a compressor:** Cycle the valve to bleed any remaining air.

## Check Valve Repair

--	--	--	--	--

**NOTE:** Kits are available for new check valve balls and seats in a range of materials. O-ring and fastener kits also are available.

**NOTE:** To ensure proper seating of the check balls, always replace the seats when replacing the balls. Also, replace the o-rings every time the manifold is removed.

## Disassemble the Check Valve

1. Follow the [Pressure Relief Procedure, page 12](#). Remove power from the motor. Disconnect all hoses.
2. **NOTE for plastic pumps:** Use hand tools until thread-locking adhesive patch releases.
3. Use a 10 mm (M8) socket wrench to remove the manifold fasteners (5) and nuts (42; used only on stainless steel models), then remove the outlet manifold (3).
4. Remove the o-rings (8) if present, seats (6), and balls (7).
5. Repeat for the inlet manifold (4), o-rings (8) if present, seats (6), and balls (7).

To continue disassembly, see [Disassemble the Diaphragms, page 14](#).

## Reassemble the Check Valve

1. Clean all parts and inspect for wear or damage. Replace parts as needed.
2. Reassemble in the reverse order, following all notes in the illustration. Put the inlet manifold on first. Be sure the ball checks (6–8) and manifolds (3, 4) are assembled **exactly** as shown. The arrows (A) on the fluid covers (2) **must** point toward the outlet manifold (3).

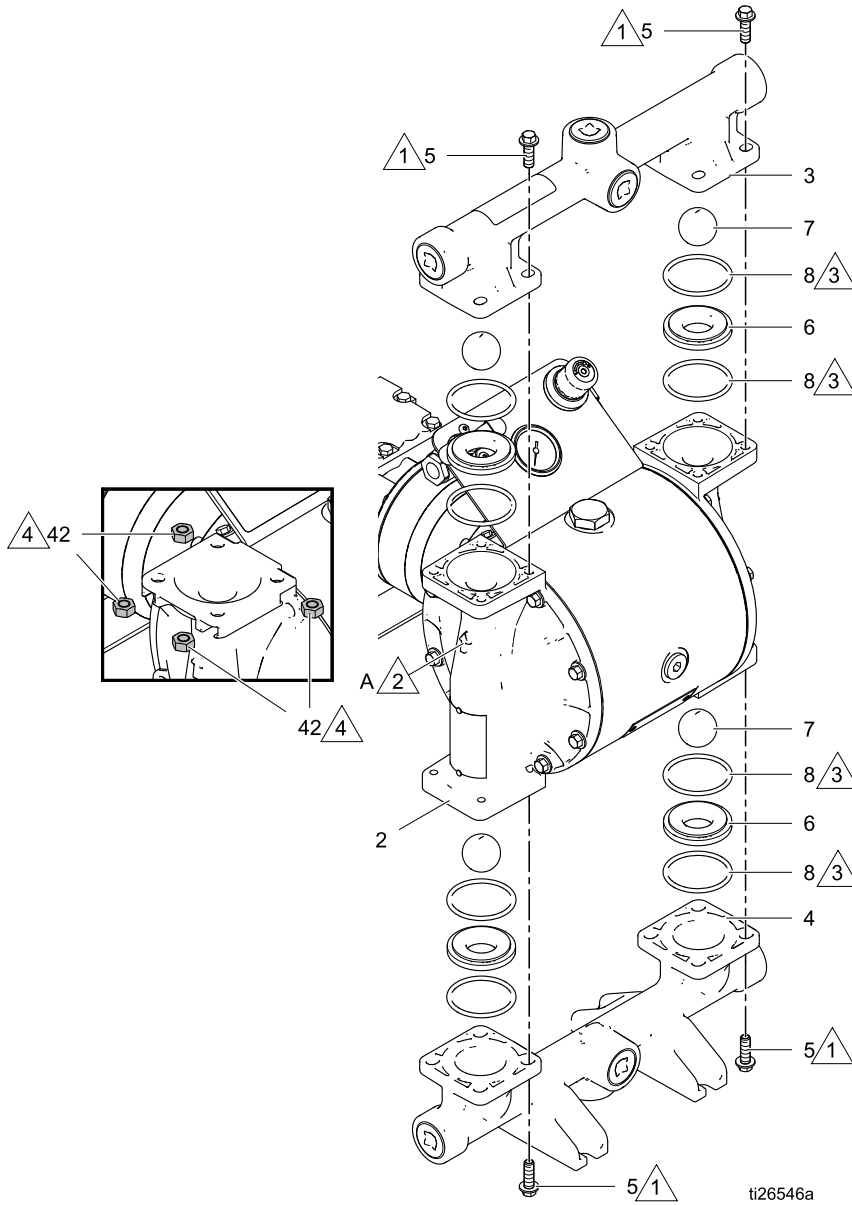
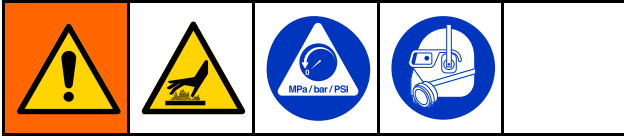

Figure 1 Check valve assembly, aluminum model shown

- △ 1 Apply medium-strength (blue) thread locker. Torque to 90 in-lb (10.2 N-m). Follow torque sequence. See [Torque Instructions, page 24](#).
- △ 2 Arrow (A) must point toward outlet manifold
- △ 3 Not used on some models.
- △ 4 Stainless steel models include nuts (42).

## Diaphragm Repair



### Disassemble the Diaphragms

**NOTE:** Diaphragm kits are available in a range of materials and styles. See Parts section.

1. Follow the [Pressure Relief Procedure, page 12](#). Remove power from the motor. Disconnect all hoses.
2. Remove the manifolds and disassemble the ball check valves as explained in [Check Valve Repair, page 12](#).
3. Use a 10 mm socket wrench to remove the bolts (5) from the fluid covers, then pull the fluid covers off of the pump.

**TIP:** On stainless steel pumps, remove the nuts (42) so they do not fall out and get lost.

4. To remove the diaphragms, the piston must be moved fully to one side. If the pump is not attached to the motor, turn the shaft by hand to move the piston. If the pump is still attached to the motor, follow the directions for your type of motor:
  - a. **AC Models:** Loosen the screws and remove the fan cover. Turn the fan by hand to rotate the shaft clockwise to shift the piston to one side.
  - b. **BLDC Models:** Remove the plug (124) and o-ring (127). Use a 10 mm socket to rotate the shaft clockwise to shift the piston to one side. Socket should move easily [no more than 1.7 N•m (15 in-lb) of torque]. If more torque is required, stop. Remove the motor. See [Center Section Repair, page 17](#).
5. **Overmolded Diaphragms (CO and PO models)**
  - a. Hold a 16 mm wrench on the wrench flats of the exposed piston shaft. The diaphragm (12) will screw off by hand. Remove the air side diaphragm plate (11).
  - b. Rotate the drive shaft to move the piston fully to one side. See instructions in step 4. Repeat step 5a.

### 6. All Other Diaphragms

- a. **Metal Pumps:** Hold a 16 mm wrench on the wrench flats of the exposed piston shaft. Use another wrench (same size) on the shaft bolt (13) to remove it. Then remove all parts of the diaphragm assembly.  
**Plastic Pumps:** Hold a 16 mm wrench on the wrench flats of the exposed piston shaft. Use a 1-1/4 socket or box end wrench on the hex of the fluid side diaphragm plate to remove it. Then remove all parts of the diaphragm assembly.
- b. Rotate the drive shaft to move the piston fully to one side. See instructions in step 4. Repeat step 6a.

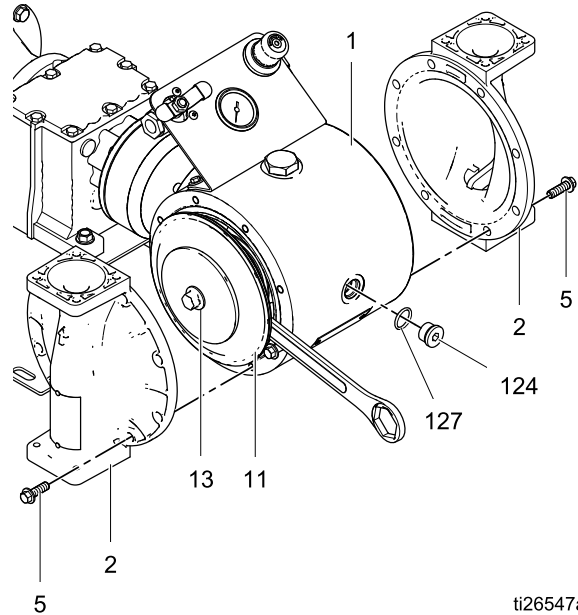

ti26547a

7. To continue with disassembly, see [Disassemble the Center Section, page 17](#).

## Reassemble the Diaphragms

Follow all notes in the illustrations on page 16. These notes contain **important** information.

### NOTICE

After reassembly, allow the thread locker to cure for 12 hours, or per manufacturer's instructions, prior to operating the pump. Damage to the pump will occur if the diaphragm shaft bolt loosens.

**TIP:** If you are also repairing or servicing the center section (drive shaft, piston, etc.), see [Center Section Repair, page 17](#), before you put the diaphragms back on.

1. Clean all parts and inspect for wear or damage. Replace parts as needed. Be sure the center section is clean and dry.
2. **Overmolded Diaphragms (CO and PO)**
  - a. If a diaphragm setscrew comes loose or is replaced, apply permanent (red) thread locker to diaphragm side threads. Screw into diaphragm until tight.
  - b. Assemble the air side plate (10) onto the diaphragm. The rounded side of the plate must face the diaphragm.
  - c. Clean the female threads of the piston shaft with a wire brush dipped in solvent to remove any residual thread locker. Apply thread-locking primer and allow it to dry.
  - d. Thoroughly clean, then apply medium-strength (blue) thread locker to the threads of the diaphragm assembly.
  - e. Hold a 16 mm wrench on the wrench flats of the piston shaft. Screw the assembly into the shaft as tight as possible by hand.
 

**TIP:** Insert a fluid cover bolt into the center section. Brace the wrench against a bolt and use two hands to tighten the diaphragm. See illustration in [Disassemble the Diaphragms, page 14](#).
  - f. Rotate the drive shaft to move the piston fully to one side. See instructions in step 4 of [Disassemble the Diaphragms, page 14](#).
  - g. Repeat to install the other diaphragm assembly.
3. **All Other Diaphragms-Metal Pumps**
  - a. Thoroughly clean or replace the piston shaft bolt (13). Install the o-ring (34).
  - b. Assemble the fluid side plate (9), the diaphragm (11), the backup diaphragm (12, if present), and the air side diaphragm plate (10) on the bolt exactly as shown.
  - c. Clean the female threads of the piston shaft with a wire brush dipped in solvent to remove any residual thread locker. Apply thread-locking primer and allow it to dry.
  - d. Apply medium-strength (blue) thread locker to the threads of the bolt.
  - e. Hold a 16 mm wrench on the wrench flats of the piston shaft. Screw the bolt onto the shaft and torque to 20–25 ft-lb (27–34 N•m).
  - f. Rotate the drive shaft to move the piston fully to one side. See instructions in step 4 of [Disassemble the Diaphragms, page 14](#).
  - g. Repeat to install the other diaphragm assembly.
4. **All Other Diaphragms-Plastic Pumps**
  - a. Thoroughly clean the threads, or replace the entire fluid side plate (9).
  - b. Assemble the diaphragm (11), the backup diaphragm (12, if present), and the air side diaphragm plate (10) on the fluid side plate (9) exactly as shown.
  - c. Clean the female threads of the piston shaft with a wire brush dipped in solvent to remove any residual thread locker. Apply thread-locking primer and allow it to dry.
  - d. Apply medium-strength (blue) thread locker to the screw threads on the fluid side plate (9).
  - e. Hold a 16 mm wrench on the wrench flats of the piston shaft. Screw the assembly into the shaft and torque to 20–25 ft-lb (27–34 N•m).

## Repair

- f. Rotate the drive shaft to move the piston fully to one side. See instructions in step 4 of [Disassemble the Diaphragms, page 14](#).
  - g. Repeat for the other diaphragm assembly.
5. Attach the fluid covers. The arrow on each fluid cover must point toward the outlet manifold. Apply medium-strength (blue) thread locker to the bolt threads. See [Torque Instructions, page 24](#), to tighten.

- 1 Rounded side faces diaphragm.
- 2 Apply medium-strength (blue) thread locker to the threads.
- 3 AIR SIDE markings on diaphragm must face the center housing.
- 4 If the screw comes loose or is replaced, apply permanent (red) thread locker to diaphragm side threads. Apply medium-strength (blue) thread locker to shaft side threads.
- 5 Torque to 20–25 ft-lb (27–34 N•m) at 100 rpm maximum.
- 6 Apply primer to the female threads. Allow to dry.

### 2-Piece (PS or PT) Models

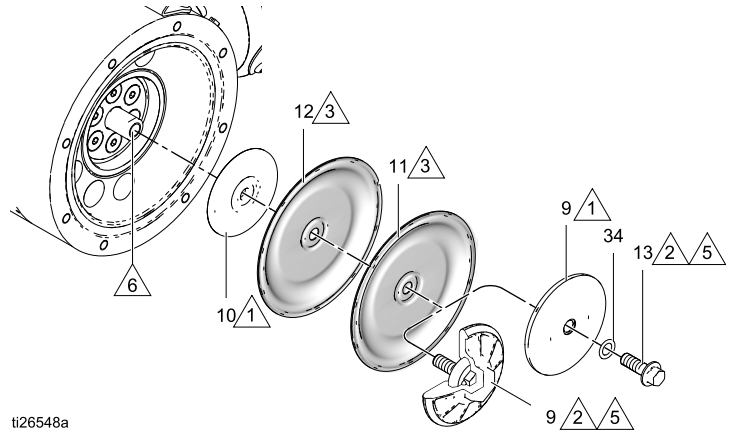

### Overmolded (PO and CO) Models

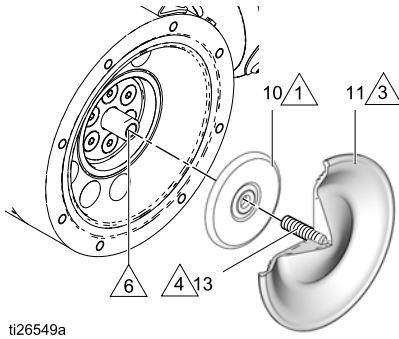

### Standard (TP, SP, BN, FK, and GE) Models

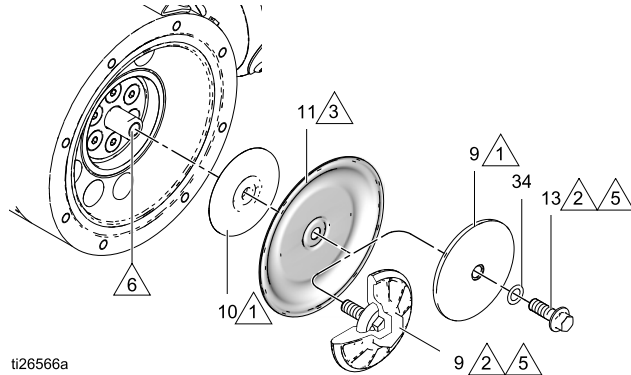

## NOTICE

After reassembly, allow the thread locker to cure for 12 hours, or per manufacturer's instructions, prior to operating the pump. Damage to the pump will occur if the diaphragm shaft bolt loosens.



## Center Section Repair

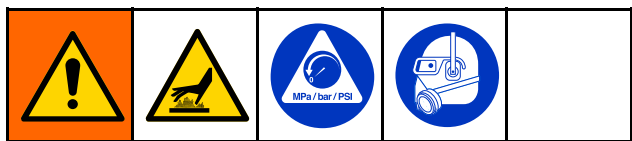

### Disassemble the Center Section

See the illustrations on page 19.

1. Follow the [Pressure Relief Procedure, page 12](#). Remove power from the motor. Disconnect all hoses.
2. Remove the manifolds and check valve parts as directed in [Disassemble the Check Valve, page 12](#).
3. Remove the fluid covers and diaphragms as directed in [Disassemble the Diaphragms, page 14](#).  
**TIP:** Clamp the gear box bracket (15) to the bench. Leave the pump connected to the motor.
4. Use a 5 mm hex wrench to remove 4 bolts (117). Pull the pump off of the alignment housing (116).  
**TIP:** It may be necessary to tap the pump with a rubber mallet to disengage the coupler.
5. Use a 5/16 hex wrench to remove the plug (124). Use a 30 mm socket wrench to remove the bearing bolt (106) and the o-ring (108) from the top.
6. Turn the shaft so the groove on the shaft is at the top, in line with the alignment markings.

7. Use a 3/4–16 bolt to push out the drive shaft assembly (112). You can also use the bearing bolt (106), but remove the bearing (107) first. Be sure that the groove on the drive shaft remains aligned with the markings in the center section.

### NOTICE

Proper alignment is essential. Do not apply more than about 10 in-lb (1.1 N•m) of torque. Excessive torque could strip the housing thread. If you encounter resistance, check alignment or contact your distributor.

8. The shaft coupler (113) might come out with the drive shaft assembly. If not, reach into the alignment housing (116) and remove the shaft coupler (113).
9. Remove the seal cartridge (110), the o-ring (109) and the radial seal (111) with o-ring (111a) from the drive shaft assembly.
10. Slide the piston assembly (102) out of the center.
11. Leave the gearbox coupler (114) attached to the gearbox shaft (118) unless it is damaged. If you need to remove it, first remove the screws (128) and the access cover (126) on the alignment housing. Turn the gearbox coupler until you have access to screw (115) on the coupler (114). Use an 8 mm hex wrench to remove the screw (115), then remove the gearbox coupler (114).

**NOTE:** Do not remove the alignment housing (116) from the gearbox unless it is damaged.

## Reassemble the Center Section

1. Clean and dry the center housing (101), the center of the piston (102) and the drive shaft (112).
2. Inspect the piston for excessive wear and replace if needed. Grease the piston as shown and install it in the center section with the groove on the top, in line with the alignment markings in the center section.
3. Install the o-ring (108) and the bearing bolt (106). Apply medium-strength (blue) thread locker and torque the bolt to 15–25 ft-lb (20–34 N•m). Be sure that the bearing (107) is in the groove on the piston, as shown. Be sure that the piston moves freely.

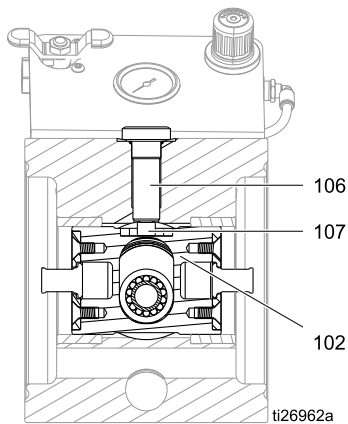

4. Be sure the sealing surface of the drive shaft (112) is clean. Install the seal cartridge (110†) and the radial seal (111†) on the drive shaft. Be sure the o-ring (111a†) is on the radial seal. The lips on the radial seal (111†) must face **IN** toward the center.

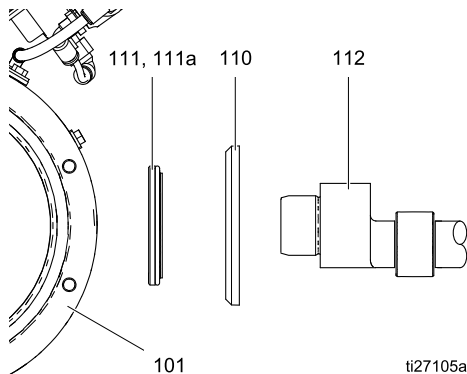

5. Install o-ring (109†).
6. Apply anti-seize lubricant on the mating edges of the drive shaft, as shown in the illustration, page 19.
7. Center the piston in the housing and install the drive shaft assembly (112) into the center housing (101) with the groove facing up.
8. Inspect the shaft coupler (113) for wear and replace if needed. Install on the drive shaft.
9. If removed, install the gearbox coupler (114) in the alignment housing (116) until the coupler seats securely on the shaft. Apply medium strength thread locker and install the screw (115). Torque to 35–45 ft-lb (47–61 N•m). Then install the access cover (126). Torque the screws (128) to 10–20 in-lb (1–2 N•m).
10. Be sure the gearbox coupler (114) is aligned properly. Turn by hand if needed. Connect the pump to the gearbox assembly, engaging the couplers.
11. Apply medium-strength (blue) thread locker and install the housing screws (117). Tighten about 5 turns at a time, in a crisscross pattern, to fully engage the coupler. Torque to 130–160 in-lb (15–18 N•m).
12. Be sure o-ring (127) is on the plug (124). Install the plug and torque to 15–25 ft-lb (20–34 N•m).
13. See [Reassemble the Diaphragms, page 15](#), and [Reassemble the Check Valve, page 12](#).

- 1 Apply medium-strength (blue) thread locker to threads.
- 2 Torque to 15–25 ft-lb (20–34 N•m).
- 3 Lips must face **IN** toward the center.
- 4 Apply anti-seize lubricant liberally on the radial surfaces of the drive shaft assembly.
- 5 Install the drive shaft assembly with the groove facing up.
- 6 Tighten screws in a crisscross pattern, 5 turns at a time, to engage the coupler evenly. Torque to 130–160 in-lb (15–18 N•m).
- 7 Apply lubricant to inner mating surface.

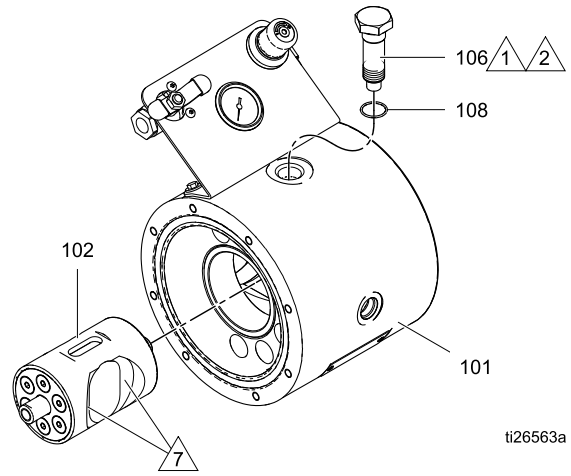

ti26563a

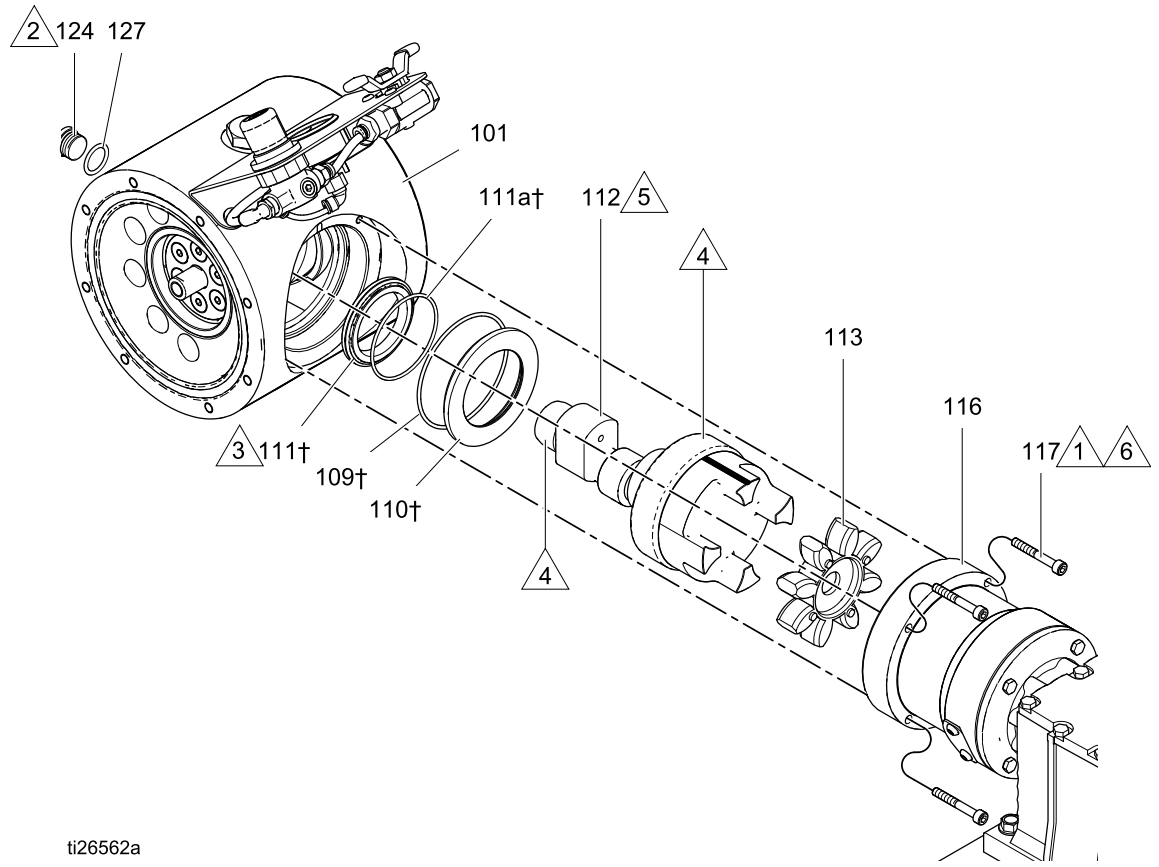

ti26562a

## Replace Center Bearing

**NOTE:** Follow this procedure only if you suspect that the center bearing is damaged. It is not necessary to replace the bearing for normal pump service. You will need Center Section Repair Tool Kit 24Y627. You also will need Bearing Puller Kit 17J718. The tool (A) was designed to work with this bearing puller.

1. Follow all steps in [Disassemble the Center Section, page 17](#).
2. Clamp the center housing (101) in a vise, with one of the bushings facing up.
3. Place the repair tool (A) on the housing with the grooved side down.
4. Remove the bushing (C). Use the upper holes on the medium-sized jaw, and the inner holes on the puller. Be sure that the jaws engage the bottom rim of the bushing. When one bushing is out, turn the housing over and repeat for the other bushing.

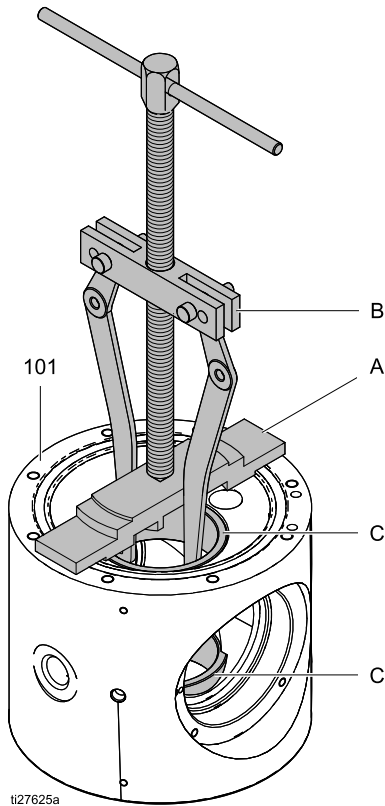

5. Place the center housing (101) in the vise with the bearing (D) side on the bottom.
6. Place the repair tool (A) on the housing with the stepped side down.

7. Remove the bearing (D). Use the lower holes on the medium-sized jaw, and the outer holes on the puller.

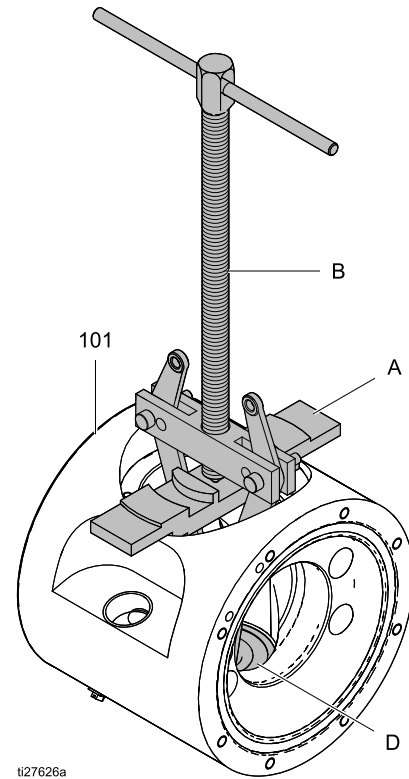

8. Use an arbor press to install the new bearing (D) into the center housing (101). Press the bearing to the shoulder in the center housing.

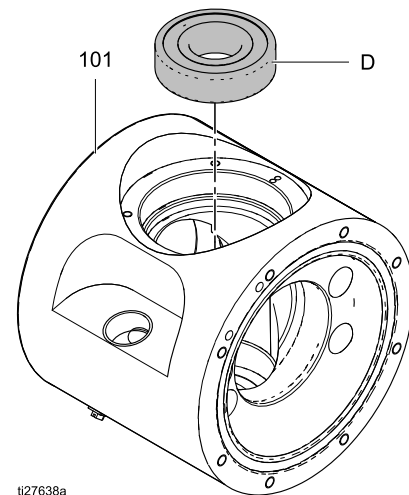

9. Use an arbor press and the press-fit tool (E) to install the two bushings (C). Install the bushings flush with the center housing (101).

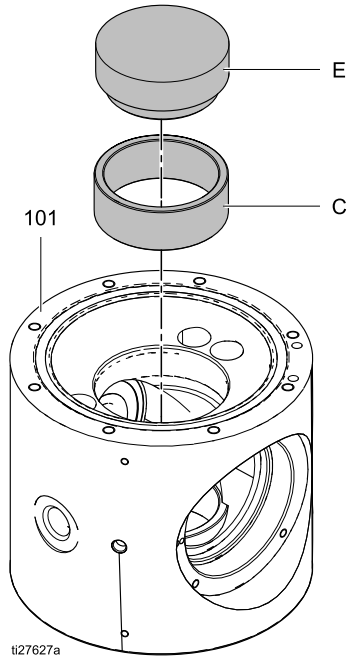

10. Follow all steps in [Reassemble the Center Section, page 18.](#)

## Disconnect the Motor and Gearbox

**NOTE:** Normally, the motor remains connected to the gearbox. Disconnect the motor only if you suspect that the motor or gearbox must be replaced.

**TIP:** Clamp the gearbox bracket (15) to the bench.

Start at step 1 for ATEX (04C), Flameproof (04D), or BLDC (04B, 05B, or 06B) motors. Standard AC motors (04A, 05A, or 06A) are of one piece with the gearbox, so begin with step 3.

1. Use a socket wrench to remove 4 screws (122).

ATEX motors (04C)	15 mm
All other motors	9/16 in.

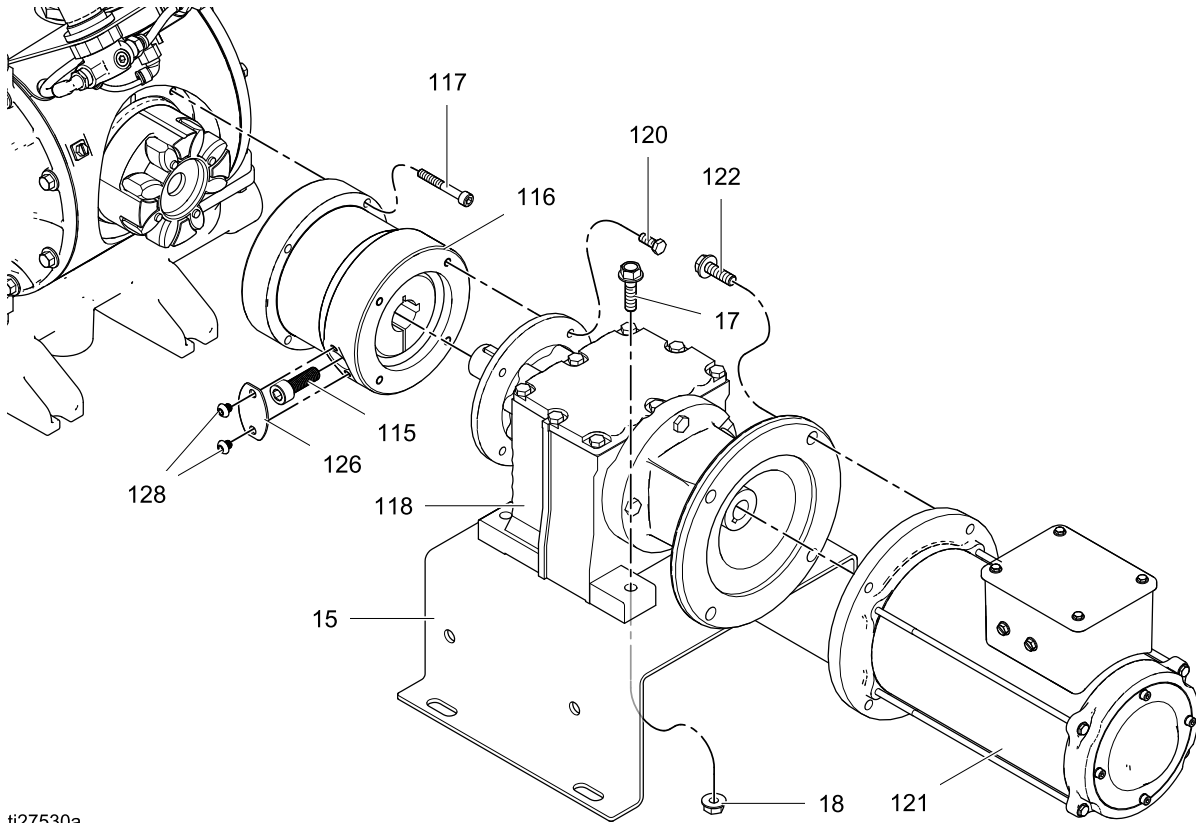

2. Pull the motor (121) straight off of the gearbox (118).

3. Use a 5 mm hex wrench to remove 4 screws (117). Pull the gearbox, with alignment housing (116) attached, off of the pump.
4. Remove the screws (128) and the access cover (126) on the alignment housing. Turn the gearbox coupler (114) until you have access to the screw (115) on the coupler. Use an 8 mm hex wrench to remove the screw (115). Remove the gearbox coupler (114).
5. Use a 10 mm socket wrench to remove 4 screws (120). Pull the alignment housing off of the gearbox.
6. Use a 10 mm socket wrench to remove 4 bolts (17) and nuts (18). Lift the gear box off of the bracket. **NOTE:** If you have an AC motor with gearbox, lift the whole unit off of the bracket.



ti27530a

## Replace the Compressor

				
<p>To avoid injury from fire, explosion, or electric shock, all electrical wiring must be done by a qualified electrician and comply with all local codes and regulations.</p>				

1. Follow the [Pressure Relief Procedure](#), page 12.
2. Remove the 8 bolts (203) holding the pump (202) to the cart (201) or another mounting surface. Use 2 people or a lift to remove the pump.

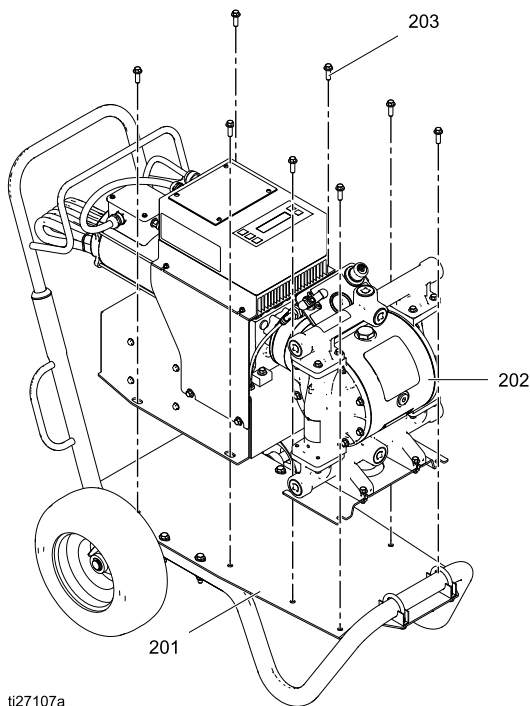

ti27107a

3. Tip the pump on its side to provide access to the compressor box.
4. Remove the air line (A1) from the compressor. Disconnect the compressor wires at the terminal block (L1, L2, and ground). Remove the four bolts, and carefully pull the compressor out of the box.
5. Use the four bolts to install the new compressor. Connect the air line from A1 to A1, as shown.
6. Connect the wires from the new compressor to the terminal block, as shown.

7. Return the pump to its mounting location or cart. Secure it with the 8 bolts.
8. Return power to the pump.

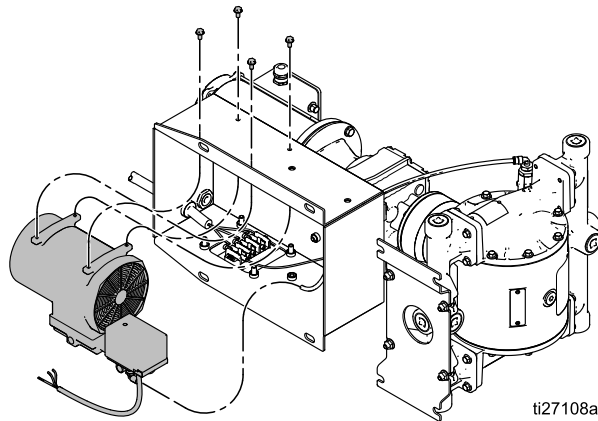

ti27108a

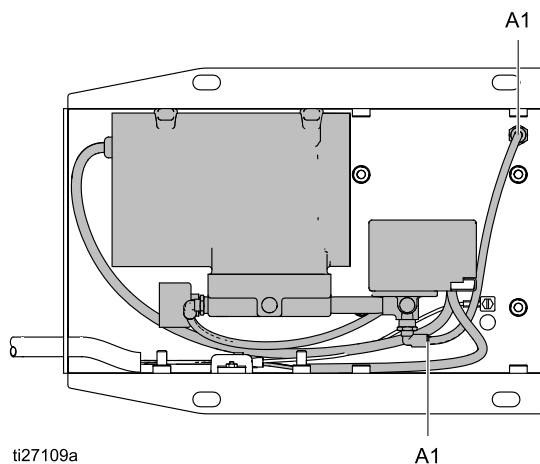

ti27109a

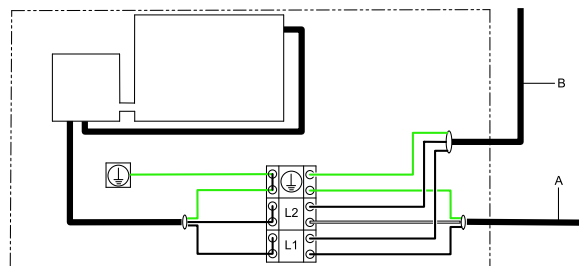

# Torque Instructions

If fluid cover or manifold fasteners have been loosened, it is important to torque them using the following procedure to improve sealing.

**NOTE:** Fluid cover and manifold fasteners have a thread-locking adhesive patch applied to the threads. If this patch is excessively worn, the fasteners may loosen during operation. Replace screws with new ones or apply medium-strength (blue) Loctite or equivalent to the threads.

**NOTE:** Always completely torque fluid covers before torquing manifolds.

1. Start all fluid cover screws a few turns. Then, turn down each screw just until head contacts cover.
2. Turn each screw by 1/2 turn or less working in a crisscross pattern in the order shown to specified torque.
3. Repeat for manifolds.

**Fluid cover and manifold fasteners:** 90 in-lb (10.2 Nm)

## Fluid Cover Screws

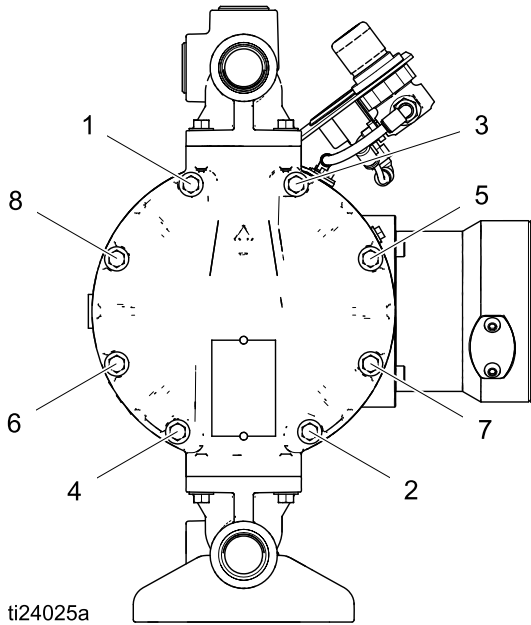

## Inlet and Outlet Manifold Screws

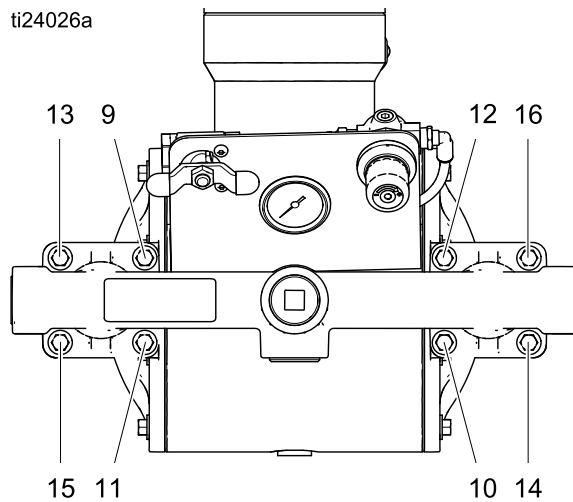





# Parts

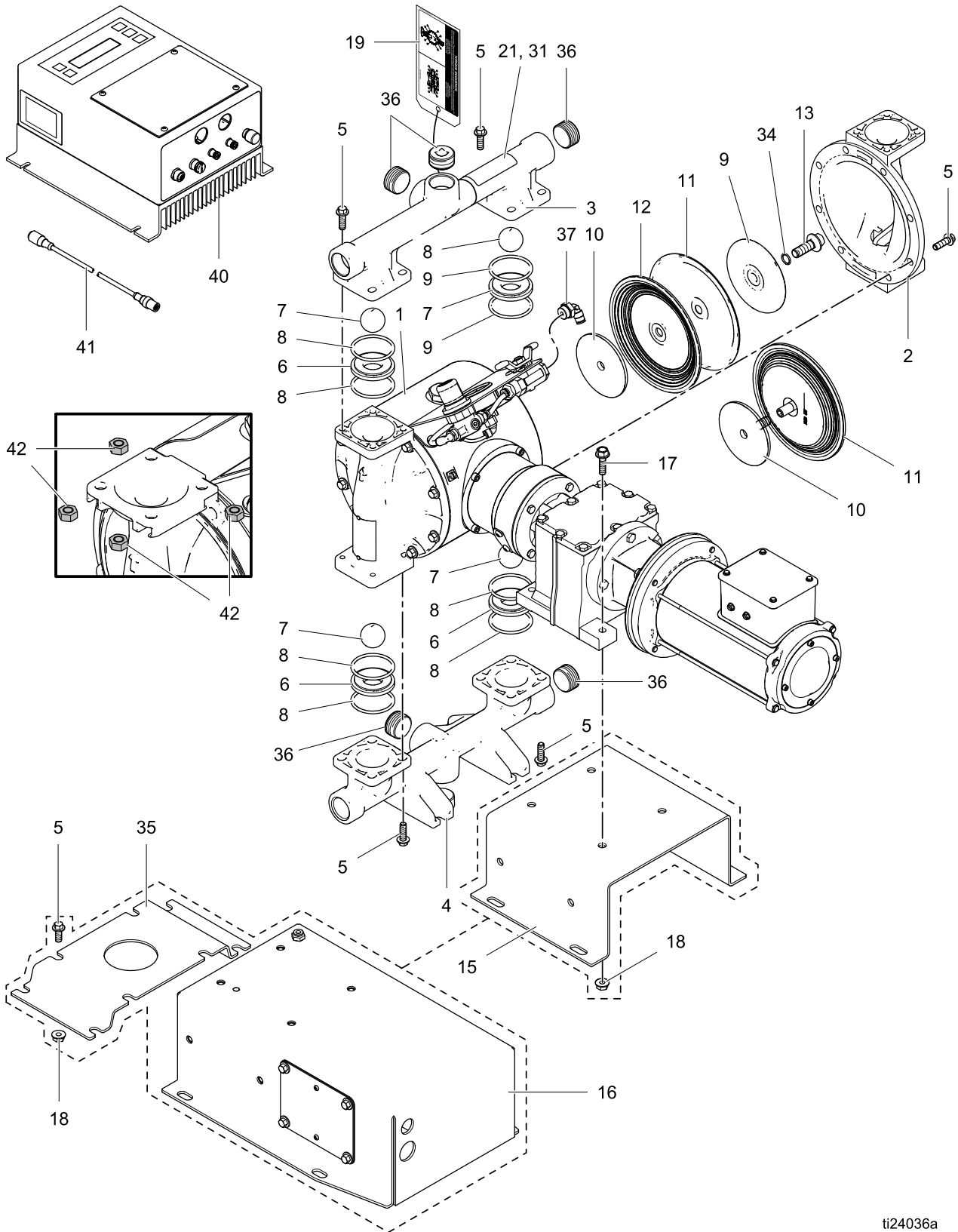

ti24036a

## Parts/Kits Quick Reference

Use this table as a quick reference for parts/kits. Go to the pages indicated in the table for a full description of kit contents.

Ref.	Part/Kit	Description	Qty.
1	---	MODULE, drive; <i>See page 29.</i>	1
2		COVER, fluid; <i>See page 32.</i>	2
	24B653	Aluminum	
	24C051	Conductive Polypropylene	
	24D347	Hastelloy	
	24C050	Polypropylene	
	24C052	PVDF	
	24C061	Stainless Steel	
3		MANIFOLD, outlet; <i>See pages 32-34</i>	1
	24B649	Aluminum, npt	
	24B650	Aluminum, bspt	
	24C039	Conductive Poly, center flange	
	24C042	Conductive Poly, end flange	
	24D343	Hastelloy, npt	
	24D344	Hastelloy, bspt	
	24C038	Polypropylene, center flange	
	24C041	Polypropylene, end flange	
	24C040	PVDF, center flange	
	24C043	PVDF, end flange	
	24C057	Stainless Steel, npt	
	24C058	Stainless Steel, bspt	
4		MANIFOLD, inlet; <i>See pages 32-34</i>	1
	24B651	Aluminum, npt	
	24B652	Aluminum, bspt	
	24C045	Conductive Poly, center flange	
	24C048	Conductive Poly, end flange	
	24D345	Hastelloy, npt	
	24D346	Hastelloy, bspt	
	24C044	Polypropylene, center flange	
	24C047	Polypropylene, end flange	
	24C046	PVDF, center flange	
	24C049	PVDF, end flange	
	24C059	Stainless Steel, npt	
	24C060	Stainless Steel, bspt	
5		FASTENERS, manifold and fluid cover; 8-pack; <i>see page 34</i>	2 pkg
	24B654	Aluminum fluid section	
	24C056	Conductive Poly, Poly, and PVDF fluid section	
	24C064	Stainless Steel and Hastelloy fluid section	
6		SEAT; 4-pack, includes 8 o-rings where needed; <i>See page 35.</i>	1 pkg
	24B630	Acetal	
	24B631	Aluminum	
	24B632	Buna-N	
	24B638	FKM Fluoroelastomer	
	24B633	Geolast	
	24B635	Polypropylene	
	24C721	PVDF	
	24B636	Santoprene	
	24B637	316 Stainless Steel (metal pumps)	
	25C818	316 Stainless Steel (plastic pumps)	
	24B634	TPE	
7		BALLS, check; 4-pack, includes 8 o-rings; <i>See page 35.</i>	1 pkg
	24B639	Acetal	
	24B640	Buna-N	
	24B643	Polychloroprene	
	24B644	Polychloroprene with SST core	
	24B648	FKM Fluoroelastomer	
	24B641	Geolast	
	24B645	PTFE	
	24B646	Santoprene	
	24B647	316 Stainless Steel	
	24B642	TPE	
8	24B655	O-RING, manifold, (not used on some models); PTFE, 8-pack; <i>See page 38.</i>	1 pkg
9	---	PLATE, fluid side; included in Air and Fluid Plate Kits; <i>See page 37.</i>	2

Parts

Ref.	Part/Kit	Description	Qty.
10	---	PLATE, air side; included in air and Fluid Plate Kits; <i>See page 37.</i>	2
11		DIAPHRAGM, kit; <i>See page 36-37.</i>	1 kit
	24B622	Buna-N Standard	
	24B629	FKM Fluoroelastomer Standard	
	24B623	Geolast Standard	
	24B628	Santoprene Standard	
	24B624	TPE Standard	
	24B625	Polychloroprene Overmolded	
	24B626	PTFE Overmolded	
	24B627	PTFE/EPDM Two-Piece	
	24F926	PTFE/Santoprene Two-Piece	
12	---	DIAPHRAGM, backup, <i>included with Ref. 11 where needed</i>	2
13	24C099	BOLT, shaft; kit; <i>includes Ref. 34</i>	2
15		BRACKET, gear box, for models without compressor; includes refs 17 and 18 for aluminum fluid section	1
	24Y538	for aluminum fluid section	
	24Y539	for hastelloy or stainless steel fluid section	
	24Y540	for conductive poly, poly, or PVDF fluid section	
16		COMPRESSOR, assembly; <i>includes Refs. 16a, 16b, 18, and 35</i>	1
	24Y542	120 Volt	
	24Y541	240 Volt	
16a		COMPRESSOR	1
	24Y544	120 Volt	
	24Y545	240 Volt	

Ref.	Part/Kit	Description	Qty.
16b	---	BOX, compressor	1
17	---	BOLT, hex washer head, M8-1.25 x 32 mm; <i>included with Ref. 15</i>	4
18	---	NUT; <i>included with Ref. 15 or 16</i>	4
19▲		TAG, torque	1
	17G058	for aluminum, hastelloy, and stainless steel fluid sections	
	17G059	for conductive poly, poly, and PVDF fluid sections	
21▲	17D277	LABEL, warning	1
31▲	17D278	LABEL, warning, multilingual	1
34	---	O-RING, for diaphragm shaft bolt; <i>included with Ref. 13</i>	2
35		BRACKET, riser; <i>used for models with a compressor for aluminum center section</i>	1
	17D358	for aluminum center section	
	17D359	for stainless steel center section	
36	24C617	PLUG; 6-pack, <i>used for models with aluminum fluid section</i>	1 pkg
37	---	ELBOW, male, swivel, 3/8 npt(f) x 1/4T; <i>used for models with a compressor</i>	1
40	24Y514	CONTROL, Husky E-Series	1
41	15Y051	CABLE, M12, 8-Pin, 3 m (9.8 ft)	1
42	112257	NUT; <i>for manifold bolts on models with stainless steel fluid section</i>	16

--- Not sold separately.

▲ Replacement Warning labels, signs, tags, and cards are available at no cost.

# Center Section

Sample Configuration Number

Pump Model	Wetted Section Material	Drive	Center Section Material	Gear Box and Motor	Fluid Covers and Manifolds	Seats	Balls	Diaphragms	Manifold O-Rings
1050	A	E	A	04A	A1	SS	BN	BN	PT

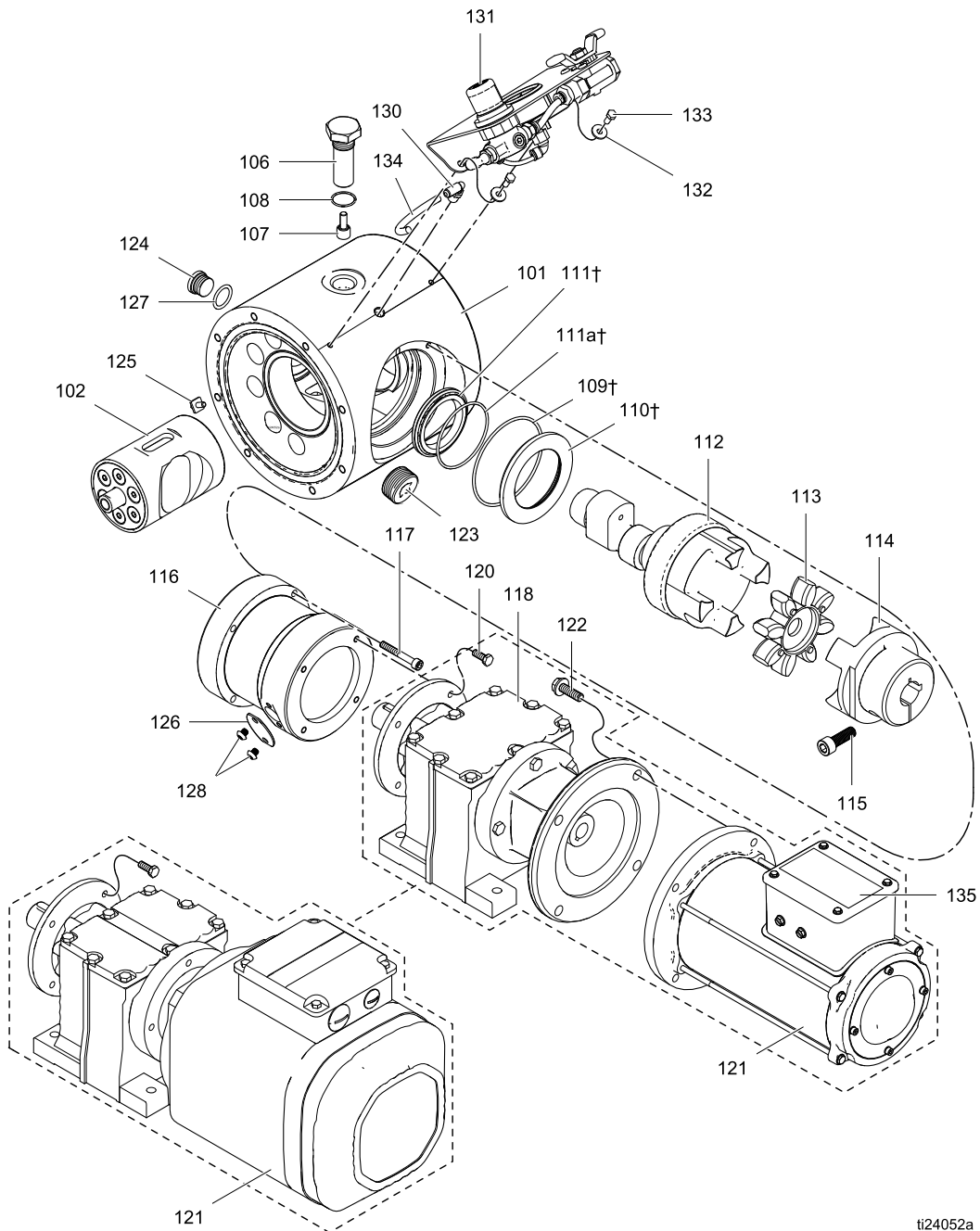

ti24052a

Parts

Ref	Part	Description	Qty
101	24Y525 24Y526	HOUSING, center, assembly; <i>includes plugs (Refs. 123, 124)</i> Aluminum ( <b>Axxx</b> ) Stainless Steel ( <b>Sxxx</b> ); <i>also includes o-ring (Ref. 127)</i>	1
102	24Y565	PISTON, assembly	1
106	24Y532 24Y533	BOLT, bearing; <i>includes Refs. 107 and 108</i> for aluminum center housing ( <b>Axxx</b> ) for stainless steel center housing ( <b>Sxxx</b> )	1
107	— — —	BEARING, cam follower. <i>included with Ref. 106</i>	1
108	— — —	O-RING, Size 019, Fluoroelastomer; <i>included with Ref. 106</i>	1
109†	— — —	O-RING, Size 153, Buna-N	1
110†	— — —	CARTRIDGE, seal	1
111†	— — —	SEAL, radial	1
111a†	— — —	O-RING, radial seal	1
112	24Y524	SHAFT, drive, assembly; <i>includes o-ring (Ref. 109), cartridge (Ref. 110) and seal (Ref. 111)</i>	1
113	24Y522	COUPLER, shaft	1
114	24Y521	COUPLER, gearbox; <i>includes screw (Ref. 115)</i>	1
115	— — —	SCREW, socket head, M10 x 30 mm ; <i>included with Ref. 114</i>	1
116	24Y527 24Y528	HOUSING, alignment, assembly; <i>includes screws (Refs. 117, 128) and access cover (Ref. 126)</i> Aluminum ( <b>Axxx</b> ) Stainless steel ( <b>Sxxx</b> )	1
117	— — —	SCREW, socket head, M6 x 40 mm; <i>included with Ref. 116</i>	4
118	17F839 17A603	GEARBOX IEC, 90 B5 Flange; used on <b>x04F</b> and <b>x04C</b> models NEMA, 56 C; used on <b>x04B</b> , <b>x05B</b> , <b>x06B</b> , <b>x04D</b> , and <b>x04E</b> models	1
120	— — —	SCREW, cap, hex head, M6 x 16 mm	4

Ref	Part	Description	Qty
121	24Y520 17F734 17F745 24S067	MOTOR AC, includes gearbox, used on <b>x04A</b> , <b>x05A</b> , and <b>x06A</b> models ATEX; used on <b>x04C</b> models EX; used on <b>x04D</b> models BLDC; used on <b>x04B</b> , <b>x05B</b> , and <b>x06B</b> models	1
122	— — —	SCREW, cap., <b>x04C</b> Hex head, 3/8–16 x 7/8; used on <b>x04B</b> , <b>x05B</b> , <b>x06B</b> , and <b>x04D</b> models Hex head, M10–1.5 x 25mm; used on <b>x04C</b> models	4
123	121497 122348	PLUG, pipe, headless for aluminum center housing ( <b>Axxx</b> ) for stainless steel center housing ( <b>Sxxx</b> )	1
124	295607 24Y534	PLUG, front access for aluminum center housing ( <b>Axxx</b> ) for stainless steel center housing ( <b>Sxxx</b> ); includes o-ring (Ref. 127)	1
125	— — —	SCREW, ground, M5 x 0.8	1
126	24Y529 24Y530	COVER, access; <i>includes screws (Ref. 128)</i> for aluminum center housing ( <b>Axxx</b> ) for stainless steel center housing ( <b>Sxxx</b> )	1
127	558730	O-RING	1
128	— — —	SCREW, button head, M6 x 6 mm	2
130	— — —	ELBOW, 1/8–27 npt; <i>included with Ref. 131</i>	1
131	24Y531	CONTROLS, air, <i>includes elbow (Ref. 130), washer (Ref. 132), tubing, and screw (Ref. 133)</i>	1
132	— — —	WASHER; <i>included with Ref. 131</i>	1
133	— — —	SCREW; <i>included with Ref. 131</i>	1
135▲	15J075	LABEL, warning	1

— — — Not sold separately.

▲ Replacement Warning labels, signs, tags, and cards are available at no cost.

† Included in Shaft Seal Repair Kit 24Y536.

## Fluid Covers and Manifolds

Sample Configuration Number

Pump Model	Wetted Section Material	Drive	Center Section Material	Gear Box and Motor	Fluid Covers and Manifolds	Seats	Balls	Diaphragms	Manifold O-Rings
1050	A	E	A	04A	A1	SS	BN	BN	PT

Fluid Cover Kits		
Kits include: 1 fluid cover (2) 4 o-rings (8)		
Aluminum		
A1, A2	24B653	<p>ti16906a</p>
Conductive Polypropylene, Polypropylene, and PVDF		
C1, C2	24C051	<p>ti26891a</p>
P1, P2	24C050	
F1, F2	24C052	
Hastelloy and Stainless Steel		
H1, H2	24D347	<p>ti26890a</p>
S1, S2	24C061	

**NOTE:** Outlet manifolds include a Warning label. Replacement warning labels, signs, tags, and cards are available at no cost.

Aluminum Manifold Kits	
Kits include: 1 manifold (3) 1 plug (36) 4 o-rings (8) 1 safety label (outlet manifolds only; ▲21)	
Outlet (3)	
A1	24B649
A2	24B650
<p>ti14307a</p>	
Inlet (4)	
A1	24B651
A2	24B652
<p>ti14308a</p>	

Sample Configuration Number

Pump Model	Wetted Section Material	Drive	Center Section Material	Gear Box and Motor	Fluid Covers and Manifolds	Seats	Balls	Diaphragms	Manifold O-Rings
1050	A	E	A	04A	<b>A1</b>	SS	BN	BN	PT

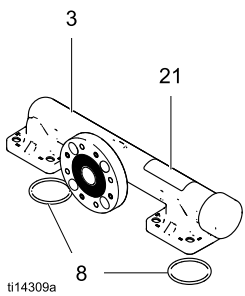
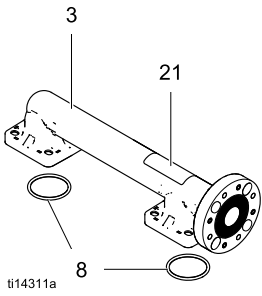
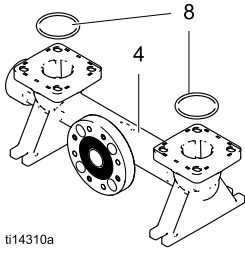
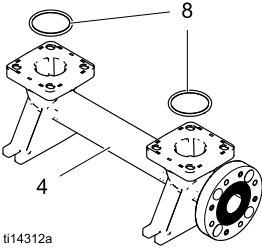
Conductive Polypropylene, Polypropylene, and PVDF Manifold Kits		
Kits include: 1 manifold (3) 4 o-rings (8) 1 safety label (outlet manifolds only; ▲21)		
Center Flange Outlet (3)		
<b>C1</b>	24C039	
<b>F1</b>	24C040	
<b>P1</b>	24C038	
End Flange Outlet (3)		
<b>C2</b>	24C042	
<b>F2</b>	24C043	
<b>P2</b>	24C041	
Center Flange Inlet (4)		
<b>C1</b>	24C045	
<b>F1</b>	24C046	
<b>P1</b>	24C044	
End Flange Inlet (4)		
<b>C2</b>	24C048	
<b>F2</b>	24C049	
<b>P2</b>	24C047	

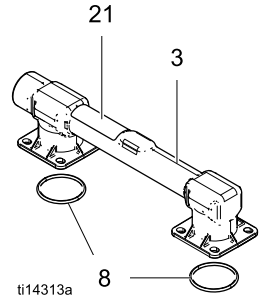
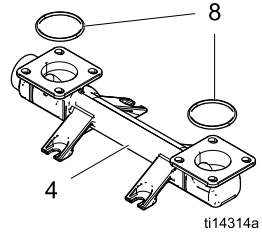
Hastelloy and Stainless Steel		
Kits include: 1 manifold (3) 4 o-rings (8) 1 safety label (outlet manifolds only; ▲21)		
Outlet (3)		
<b>H1</b>	24D343	
<b>H2</b>	24D344	
<b>S1</b>	24C057	
<b>S2</b>	24C058	
Inlet (4)		
<b>H1</b>	24D345	
<b>H2</b>	24D346	
<b>S1</b>	24C059	
<b>S2</b>	24C060	

Manifold/Fluid Cover Fastener Kits	
<b>A1, A2</b>	24B654
Kit includes: • 8 bolts; carbon steel, hex washer head; M8 x 25	
<b>C1, C2, F1, F2, P1, P2</b>	24C056
Kit includes: • 8 bolts, 300 series stainless steel; hex flange, M8 x 32 • 8 nuts	
<b>H1, H2, S1, S2</b>	24C064
Kit includes: • 8 bolts, 300 series stainless steel; hex washer head, M8 x 20 • 8 nuts	



## Seats and Check Balls

Sample Configuration Number

Pump Model	Wetted Section Material	Drive	Center Section Material	Gear Box and Motor	Fluid Covers and Manifolds	Seats	Balls	Diaphragms	Manifold O-Rings
1050	A	E	A	04A	A1	<b>SS</b>	<b>BN</b>	BN	PT

Seat Kits	
<b>AC</b>	24B630
<b>AL</b>	24B631
<b>BN</b>	24B632
<b>FK</b>	24B638
<b>GE</b>	24B633
<b>PP</b>	24B635
<b>PV</b>	24C721
<b>SP</b>	24B636
<b>SS</b>	24B637 (metal pumps)
	25C818 (plastic pumps)
<b>TP</b>	24B634

Kits include:

- 4 seats (6), material indicated in table.
- 8 o-rings (8), PTFE, not used on models with Buna-N, FKM, or TPE seats.

Ball Kits	
<b>AC</b>	24B639
<b>BN</b>	24B640
<b>CR</b>	24B643
<b>CW</b>	24B644
<b>FK</b>	24B648
<b>GE</b>	24B641
<b>PT</b>	24B645
<b>SP</b>	24B646
<b>SS</b>	24B647
<b>TP</b>	24B642

Kits include:

- 4 balls (7), material indicated in table.
- 8 o-rings (8); not used on models with Buna-N, FKM, or TPE seats.

## Diaphragms

Sample Configuration Number

Pump Model	Wetted Section Material	Drive	Center Section Material	Gear Box and Motor	Fluid Covers and Manifolds	Seats	Balls	Diaphragms	Manifold O-Rings
1050	A	E	A	04A	A1	SS	BN	<b>BN</b>	PT

1-Piece Bolt-Through Diaphragm Kits	
<b>BN</b>	24B622
<b>FK</b>	24B629
<b>GE</b>	24B623
<b>SP</b>	24B628
<b>TP</b>	24B624

Kits include:

- 2 diaphragms (11), material indicated in table
- 2 o-rings (34); used on metal pumps
- 1 diaphragm install tool; not used
- 8 o-rings (8); not used on models with Buna-N, FKM, or TPE seats.

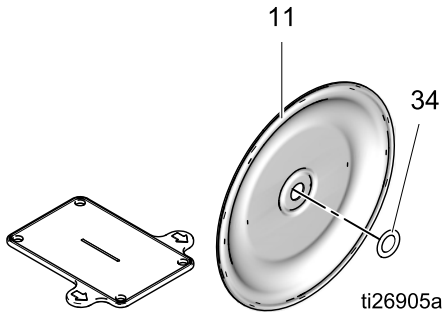

Overmolded Diaphragm Kit	
<b>CO</b>	24B625
<b>PO</b>	24B626

Kits include:

- 2 overmolded diaphragms (11), material indicated in table.
- 2 diaphragm set screws (13)
- 1 diaphragm install tool; not used
- 1 packet anaerobic adhesive
- 1 packet sealant

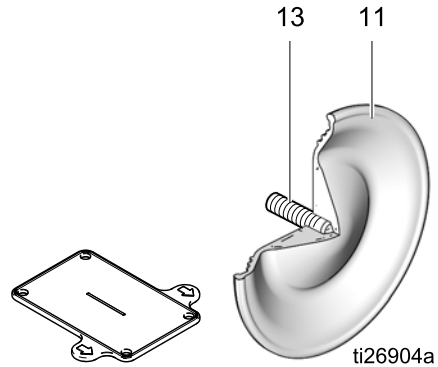

Sample Configuration Number

Pump Model	Wetted Section Material	Drive	Center Section Material	Gear Box and Motor	Fluid Covers and Manifolds	Seats	Balls	Diaphragms	Manifold O-Rings
1050	A	E	A	04A	A1	SS	BN	<b>BN</b>	PT

2-Piece Bolt-Through Diaphragm Kit	
<b>PS</b>	24F926
<b>PT</b>	24B627

Kits include:

- 2 diaphragms (11), PTFE
- 2 backup diaphragms (12), material indicated in table
- 2 o-rings (34); used on metal pumps
- 1 diaphragm install tool; not used
- 8 o-rings (8); PTFE

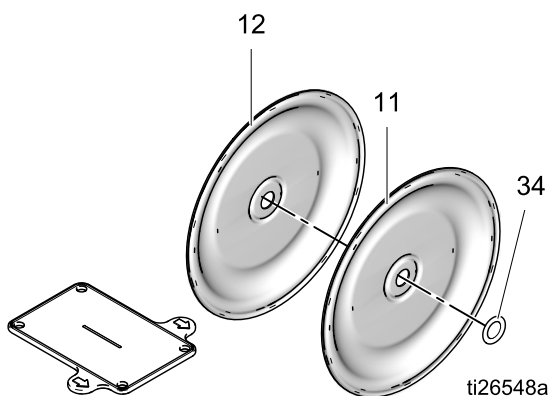

Diaphragm Shaft Bolt	
<b>Metal Pumps</b>	24C099

Kits include:

- 1 bolt (13); stainless steel, M12 x 35
- 1 o-ring (34)

Air and Fluid Plate Kits	
<b>A1, A2</b>	24C035
<b>C1, C2, P1, P2</b>	24C036
<b>F1, F2</b>	24C037
<b>H1, H2</b>	24D342
<b>S1, S2</b>	24C062

Kits for aluminum, hastelloy, and stainless steel pumps include:

- 1 air side diaphragm plate (10)
- 1 fluid side diaphragm plate (9)
- 1 o-ring (34)
- 1 bolt (13)

Kits for polypropylene, conductive polypropylene, and PVDF pumps include:

- 1 air side diaphragm plate (10)
- 1 fluid side diaphragm plate (9, includes bolt)

## Manifold Seals

*Sample Configuration Number*

Pump Model	Wetted Section Material	Drive	Center Section Material	Gear Box and Motor	Fluid Covers and Manifolds	Seats	Balls	Diaphragms	Manifold O-Rings
1050	A	E	A	04A	A1	SS	BN	BN	<b>PT</b>

Manifold O-Ring Kits	
<b>PT</b>	24W212

Kits include:

- 8 o-rings (9), PTFE; not used on models with Buna-N, FKM, or TPE seats.

# Cart

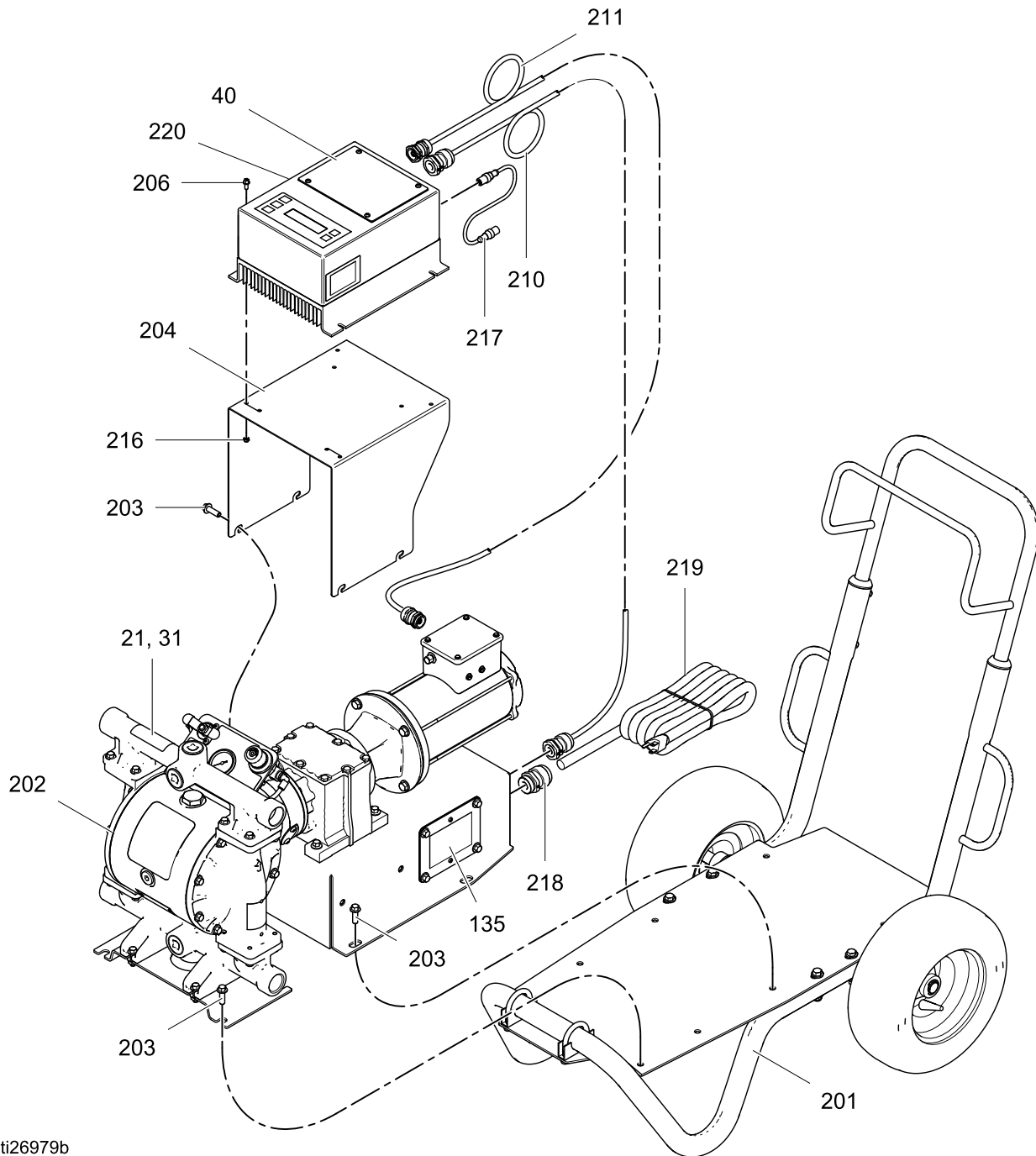

ti26979b

**Cart-Mounted Models**

Ref	Part	Description	Qty
201	24Y543	CART; <i>includes screws (Ref. 203)</i>	1
202	See Table	PUMP	1
203	— — —	SCREW; M8–1.25 x 25 mm; <i>included with Ref. 201</i>	12
204	24Y537	BRACKET, control box; Included screws (203, 206) and nuts (216).	1
40	24Y514	CONTROLLER, Graco Motor Control	1
206	— — —	SCREW, M5–0.8 x 12 mm; <i>included with Ref. 204</i>	4
210	17L370	CABLE, compressor	1
211	17L368	CABLE, motor	1
216	— — —	NUT, lock; <i>included with Ref. 204</i>	4
217	17F709	CABLE, M12, 8–pin, 1 ft (0.3 m)	1
218	— — —	CONNECTOR, strain relief	1
219	— — —	CORD, power (120V)	1
220	17B772	LABEL, warning	1

▲ Replacement Warning labels, signs, tags, and cards are available at no cost.

**Table 1 Pumps Used on Cart-Mounted Models**

Cart Model	Pump Model (ref. 202)
24Y388	648190
24Y552	648250
24Y553	648183
24Y554	648243
24Y555	648180
24Y556	648240
24Y557	648187
24Y558	648247
24Y559	650110
24Y560	650154
24Y561	651908
24Y562	651944

Cart

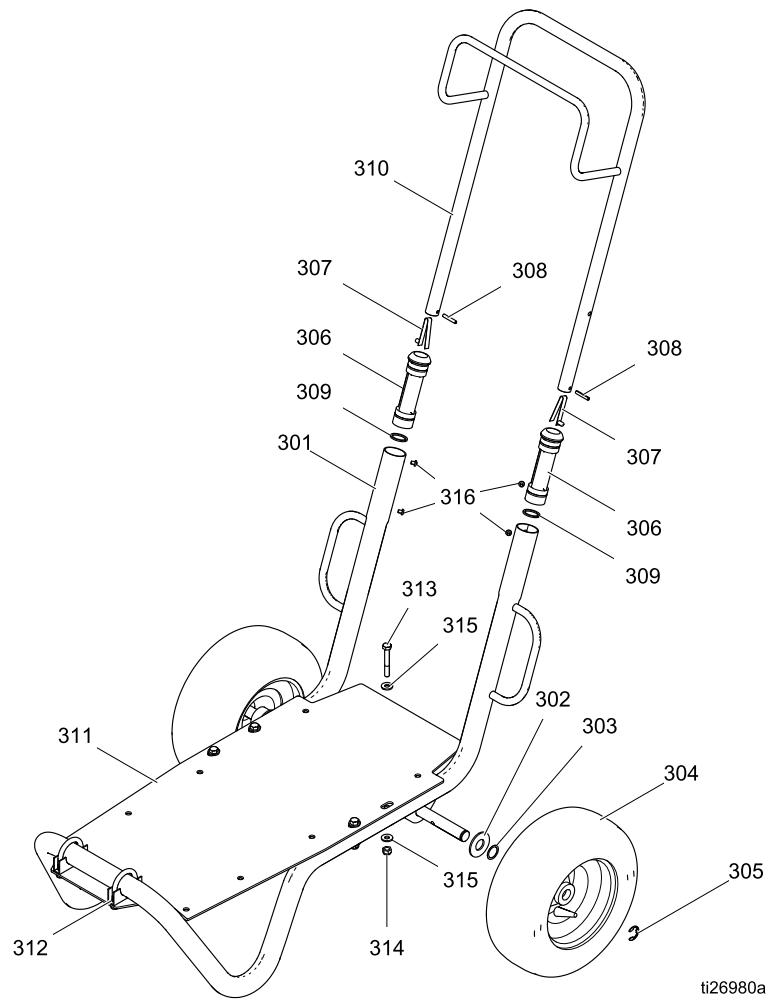

Ref	Part	Description	Qty
301	---	FRAME	1
302	156306	WASHER, flat	2
303	116038	WASHER, wave spring	2
304	119420	WHEEL, pneumatic	2
305	120211	E-RING, retaining	2
306	192027	SLEEVE	2
307	112827	BUTTON, snap	2
308	101354	PIN, spring, straight	2

Ref	Part	Description	Qty
309	15J645	WASHER	2
310	24M397	HANDLE	1
311	---	PLATE	1
312	---	CLAMP	2
313	108481	SCREW, 5/16-18 X 2.25	4
314	111040	NUT, lock	4
315	100527	WASHER	8
316	109032	SCREW, #10-32 x 0.25	4

## Kits and Accessories

### For AC and BLDC Motors

#### Leak Sensor Kit 24Y661

Upgrade kit, to add a leak sensor to an existing system. Includes leak sensor and bushing.

**NOTE:** Also purchase a cable from the following selections. For systems with BLDC motors that use a Graco Motor Control, order an extension cable from the first section. For systems with AC motors that use a VFD, order a field-wireable cable from the second section.

#### Leak Sensor/PLC Extension Cables (For BLDC Motors)

M8, 4-pin (both ends)

Part	Description
121683	9.8 ft; 3.0 m
17H349	24.6 ft; 7.5 m
17H352	52.5 ft; 16 m

#### Leak Sensor Cables; Field Wireable (for VFDs)

M8, 4-pin (one end, flying leads on other end)

Part	Description
17H389	9.8 ft; 3.0 m
17H390	24.6 ft; 7.5 m
17H391	52.5 ft; 16 m

#### Compressor Upgrade Kits 24Y542 (120V) and 24Y541 (240V)

Upgrade kits include compressor, compressor box, brackets, and mounting hardware.

#### Center Section Repair Tool Kit 24Y627

Includes tools needed to remove the bearing from the center section.

#### Bearing Puller Kit 17J718

Includes an interchangeable bearing puller set.

#### Controller-to-Motor cables

Preassembled cable to wire the motor controller to the motor. Includes cable, strain reliefs, and terminals.

Part	Description
17L368	1.0 ft; 0.3 m
17S306	9.8 ft; 3.0 m

#### Compressor-to-Controller cables

Preassembled cable to wire the compressor to the motor controller. Includes cable, strain reliefs, and terminals.

Part	Description
17L370	2.0 ft; 0.6 m
17S308	9.8 ft; 3.0 m

### For BLDC Motors

#### Graco Motor Control Kit 24Y514

Replacement kit includes Graco Motor Control with necessary software.

#### Software Upgrade Kit 17H104

Upgrade kit includes software token and instructions.

**NOTE:** Also purchase Programming Cable Kit 24Y788.

#### Motor Feedback Cables

M12, 8-pin (both ends)

Part	Description
17F709	1.0 ft; 0.3 m
15Y051	9.8 ft; 3.0 m
16X521	24.6 ft; 7.5 m
16P791	52.5 ft; 16 m

#### PLC Control Cable

M8, 4-pin (one end, flying leads on other end)

Part	Description
17H365	9.8 ft; 3.0 m
17H366	24.6 ft; 7.5 m
17H367	52.5 ft; 16 m



# Technical Data

	US	Metric
<b>Husky 1050e Electric Double Diaphragm Pump</b>		
Maximum fluid working pressure	70 psi	0.48 MPa, 4.8 bar
Maximum incoming air pressure	150 psi	1.03 MPa, 10.3 bar
Center section air charge range	20 to 80 psi	0.14–0.55 MPa, 1.4–5.5 bar
Maximum air consumption	<0.2 scfh	<0.006 cubic meters/hour
Air inlet size	3/8 in. npt(f)	
Maximum suction lift (reduced if balls don't seat well due to damaged balls or seats, lightweight balls, or extreme speed of cycling)	Wet: 29 ft Dry: 16 ft	Wet: 8.8 m Dry: 4.9 m
Maximum size pumpable solids	1/8 in.	3.2 mm
Ambient air temperature range for operation and storage. <b>NOTE:</b> Exposure to extreme low temperatures may result in damage to plastic parts.	32° F–104° F	0° C–40° C
Fluid displacement per cycle	0.14 gallons	0.53 liters
Maximum free-flow delivery	39 gpm	148 lpm
Maximum pump speed	280 cpm	
<b>Fluid Inlet and Outlet Size</b>		
Aluminum, Hastelloy, or Stainless Steel	1 in npt(f) or 1 in bspt	
Polypropylene, Conductive Polypropylene, or PVDF	1 in. ANSI/DIN Raised Face Flange	
<b>Electric Motor</b>		
AC, Standard CE (04A, 05A, 06A)		
Power	2 HP	1.5 kW
Number of Motor Poles	4-Pole	
Speed	1800 rpm (60 Hz) or 1500 rpm (50 Hz)	
Constant Torque	6:1	
Gear Ratio	8.16	
Voltage	3-phase 230V / 3-Phase 460V	
Maximum Amperage Load	5.7 A (230V) / 2.85 A (460V)	
Ingress Protection	IP66	
IE Rating	IE2	
AC, ATEX (04C)		
Power	2 HP	1.5 kW
Number of Motor Poles	2-Pole	
Speed	3420 rpm (60 Hz) or 2850 rpm (50 Hz)	
Constant Torque	10:1	
Gear Ratio	18.08	
Voltage	3-phase 240V / 3-Phase 415V	
Maximum Amperage Load	5.44 A (230V) / 3.14 A (460V)	
Ingress Protection	IP55	
IE Rating	IE1	

Technical Data

	US	Metric
<b>AC, Explosionproof (04D)</b>		
Power	2 Hp	1.5 kW
Number of Motor Poles	2-Pole	
Speed	3450 rpm (60 Hz) or 2875 rpm (50 Hz)	
Constant Torque	20:1	
Gear Ratio	18.08	
Voltage	3-phase 230V / 3-Phase 460V	
Maximum Amperage Load	5.2 A (230V) / 2.6 A (460V)	
Ingress Protection	IP54	
IE Rating	IE2	
<b>BLDC (04B, 05B, 06B)</b>		
Power	2.2 Hp	1.6 kW
Speed	3600 rpm	
Gear Ratio	11.86	
Voltage	320 VDC	
Maximum Amperage Load	5.2 A	
Ingress Protection	IP56	
<b>Motorless Gearbox</b>		
<b>NEMA (04E)</b>		
Mounting Flange	NEMA 56 C	
Gear Ratio	18.08	
<b>IEC (04F)</b>		
Mounting Flange	IEC 90	
Gear Ratio	18.08	
<b>Noise Data</b>		
Sound Power (measured per ISO-9614-2)		
at 70 psi fluid pressure and 50 cpm	71 dBa	
at 30 psi fluid pressure and 280 cpm (full flow)	94 dBa	
Sound Pressure [tested 3.28 ft (1 m) from equipment]		
at 70 psi fluid pressure and 50 cpm	61 dBa	
at 30 psi fluid pressure and 280 cpm (full flow)	84 dBa	

	US	Metric
<b>Wetted Parts</b>		
Wetted parts include material(s) chosen for seat, ball, and diaphragm options, <b>plus the fluid section's material of construction: Aluminum, Hastelloy, Polypropylene, Conductive Polypropylene, PVDF, or Stainless Steel</b>		
Non-wetted parts		
Aluminum	aluminum, coated carbon steel, bronze	
Hastelloy	hastelloy, stainless steel, aluminum (if used in center section), bronze	
Plastic	stainless steel, polypropylene, coated carbon steel, bronze	
Stainless Steel	stainless steel, aluminum, coated carbon steel, bronze	
<b>Technical Specifications for the Graco Motor Control</b> (All installations and wiring must comply with NEC and local electrical codes.)		
DC Power Supply	Class 2 Power Supply only	
Approvals	UL508C	
Conformity	CE-Low Voltage (2006/95/EC), EMC (2004/108/EC), and RoHS (2011/65/EU) Directives	
Ambient Temperature	-40°F – 104°F	-40°C – 40°C
Environment Rating	Type 4X, IP 66	
Overtemperature Sensing Specifications (The drive is provided with a means to accept and act upon a signal from a thermal sensor in the motor. Motor overtemperature sensing is required to provide the motor overload protection.)	0–3.3 VDC, 1mA maximum	
<b>Input Specifications</b>		
Input Line Voltage	120/240 VAC, line-to-line	
Input Line Phasing	Single Phase	
Input Line Frequency	50/60 Hz	
Input Current per Phase	16A	
Maximum Branch Circuit Protection Rating	20A, Inverse Time Circuit Breaker	
Short Circuit Current Rating	5 kA	
<b>Output Specifications</b>		
Output Line Voltage	0–264 VAC	
Output Line Phasing	Three Phase	
Output Current (Current limit, set via the software, is provided as a secondary protection from motor overload.)	0–12A	
Output Power	1.92 KW / 2.6 hp	
Output Overload	200% for 0.2 seconds	

## Weights

Pump Material		Motor/Gearbox											
Fluid Section	Center Section	AC		ATEX + IEC		Flameproof + NEMA		NEMA		IEC		BLDC+ NEMA	
		lb	kg	lb	kg	lb	kg	lb	kg	lb	kg	lb	kg
Aluminum	Aluminum	106	48.1	144	65.3	109.5	49.7	69.5	31.5	74	33.6	90	40.8
Conductive Polypropylene	Aluminum	103.5	46.9	141.5	64.1	107	48.5	67	30.4	71.5	32.4	87.5	39.7
Conductive Polypropylene	Stainless Steel	135	61.2	173	78.5	138.5	62.8	98.5	44.7	103	46.7	119	54.0
Hastelloy	Stainless Steel	153	69.4	191	86.6	156.5	71.0	116.5	52.8	121	54.9	137	62.1
Polypropylene	Aluminum	103.5	46.9	141.5	64.2	106.5	48.3	67	30.4	71.5	32.4	87.5	39.7
Polypropylene	Stainless Steel	135	61.2	173	78.5	138.5	62.8	98.5	44.7	103	46.7	119	54.0
PVDF	Aluminum	109	49.4	147	66.7	112.5	51.0	72.5	32.9	77	34.9	93	42.2
PVDF	Stainless Steel	140.5	63.7	178.5	81.0	144	63.7	104	47.2	108.5	49.2	124.5	56.5
Stainless Steel	Aluminum	121.5	55.1	159.5	72.3	125	55.5	85	38.6	89.5	40.6	105.5	47.9
Stainless Steel	Stainless Steel	153	69.4	191	86.6	156.5	71.0	116.5	52.8	121	54.9	137	62.1

Component/Model	U.S.	Metric
Compressor	28 lb	13 kg
Graco VFD	6 lb	3 kg
Graco Motor Control	10.5 lb	4.8 kg
Cart Models		
24Y388, 24Y552, and 24Y588	184.5 lb	83.7 kg
24Y559 and 24Y560	182 lb	82.6 kg
24Y561 and 24Y562	200 lb	90.7 kg

## Fluid Temperature Range

### NOTICE

Temperature limits are based on mechanical stress only. Certain chemicals will further limit the fluid temperature range. Stay within the temperature range of the most-restricted wetted component. Operating at a fluid temperature that is too high or too low for the components of your pump may cause equipment damage.

Diaphragm/Ball/Seat Material	Fluid Temperature Range					
	Aluminum Hastelloy, or Stainless Steel Pumps		Polypropylene or Conductive Polypropylene Pumps		PVDF Pumps	
	Fahrenheit	Celsius	Fahrenheit	Celsius	Fahrenheit	Celsius
Acetal (AC)	10° to 180°F	-12° to 82°C	32° to 150°F	0° to 66°C	10° to 180°F	-12° to 82°C
Buna-N (BN)	10° to 180°F	-12° to 82°C	32° to 150°F	0° to 66°C	10° to 180°F	-12° to 82°C
FKM Fluoroelastomer (FK)*	-40° to 275°F	-40° to 135°C	32° to 150°F	0° to 66°C	10° to 225°F	-12° to 107°C
Geolast® (GE)	-40° to 150°F	-40° to 66°C	32° to 150°F	0° to 66°C	10° to 150°F	-12° to 66°C
Polychloroprene overmolded diaphragm (CO) or Polychloroprene check balls (CR or CW)	0° to 180°F	-18° to 82°C	32° to 150°F	0° to 66°C	10° to 180°F	-12° to 82°C
Polypropylene (PP)	32° to 150°F	0° to 66°C	32° to 150°F	0° to 66°C	32° to 150°F	0° to 66°C
PTFE overmolded diaphragm (PO)	40° to 180°F	4° to 82°C	40° to 150°F	4° to 66°C	40° to 180°F	4° to 82°C
PTFE check balls or two-piece PTFE/EPDM diaphragm (PT)	40° to 220°F	4° to 104°C	40° to 150°F	4° to 66°C	40° to 220°F	4° to 104°C
PVDF (PV)	10° to 225°F	-12° to 107°C	32° to 150°F	0° to 66°C	10° to 225°F	-12° to 107°C
Santoprene® check balls (SP) or 2-piece PTFE/Santoprene diaphragm (PS)	-40° to 180°F	-40° to 82°C	32° to 150°F	0° to 66°C	10° to 225°F	-12° to 107°C
TPE (TP)	-20° to 150°F	-29° to 66°C	32° to 150°F	0° to 66°C	10° to 150°F	-12° to 66°C

\* The maximum temperature listed is based on the ATEX standard for T4 temperature classification. If you are operating in a non-explosive environment, FKM fluoroelastomer's maximum fluid temperature in aluminum or stainless steel pumps is 320°F (160°C).

# Graco Standard Warranty

Graco warrants all equipment referenced in this document which is manufactured by Graco and bearing its name to be free from defects in material and workmanship on the date of sale to the original purchaser for use. With the exception of any special, extended, or limited warranty published by Graco, Graco will, for a period of twelve months from the date of sale, repair or replace any part of the equipment determined by Graco to be defective. This warranty applies only when the equipment is installed, operated and maintained in accordance with Graco's written recommendations.

This warranty does not cover, and Graco shall not be liable for general wear and tear, or any malfunction, damage or wear caused by faulty installation, misapplication, abrasion, corrosion, inadequate or improper maintenance, negligence, accident, tampering, or substitution of non-Graco component parts. Nor shall Graco be liable for malfunction, damage or wear caused by the incompatibility of Graco equipment with structures, accessories, equipment or materials not supplied by Graco, or the improper design, manufacture, installation, operation or maintenance of structures, accessories, equipment or materials not supplied by Graco.

This warranty is conditioned upon the prepaid return of the equipment claimed to be defective to an authorized Graco distributor for verification of the claimed defect. If the claimed defect is verified, Graco will repair or replace free of charge any defective parts. The equipment will be returned to the original purchaser transportation prepaid. If inspection of the equipment does not disclose any defect in material or workmanship, repairs will be made at a reasonable charge, which charges may include the costs of parts, labor, and transportation.

**THIS WARRANTY IS EXCLUSIVE, AND IS IN LIEU OF ANY OTHER WARRANTIES, EXPRESS OR IMPLIED, INCLUDING BUT NOT LIMITED TO WARRANTY OF MERCHANTABILITY OR WARRANTY OF FITNESS FOR A PARTICULAR PURPOSE.**

Graco's sole obligation and buyer's sole remedy for any breach of warranty shall be as set forth above. The buyer agrees that no other remedy (including, but not limited to, incidental or consequential damages for lost profits, lost sales, injury to person or property, or any other incidental or consequential loss) shall be available. Any action for breach of warranty must be brought within two (2) years of the date of sale.

**GRACO MAKES NO WARRANTY, AND DISCLAIMS ALL IMPLIED WARRANTIES OF MERCHANTABILITY AND FITNESS FOR A PARTICULAR PURPOSE, IN CONNECTION WITH ACCESSORIES, EQUIPMENT, MATERIALS OR COMPONENTS SOLD BUT NOT MANUFACTURED BY GRACO.** These items sold, but not manufactured by Graco (such as electric motors, switches, hose, etc.), are subject to the warranty, if any, of their manufacturer. Graco will provide purchaser with reasonable assistance in making any claim for breach of these warranties.

In no event will Graco be liable for indirect, incidental, special or consequential damages resulting from Graco supplying equipment hereunder, or the furnishing, performance, or use of any products or other goods sold hereto, whether due to a breach of contract, breach of warranty, the negligence of Graco, or otherwise.

## FOR GRACO CANADA CUSTOMERS

The Parties acknowledge that they have required that the present document, as well as all documents, notices and legal proceedings entered into, given or instituted pursuant hereto or relating directly or indirectly hereto, be drawn up in English. Les parties reconnaissent avoir convenu que la rédaction du présente document sera en Anglais, ainsi que tous documents, avis et procédures judiciaires exécutés, donnés ou intentés, à la suite de ou en rapport, directement ou indirectement, avec les procédures concernées.

## Graco Information

For the latest information about Graco products, visit [www.graco.com](http://www.graco.com).  
For patent information, see [www.graco.com/patents](http://www.graco.com/patents).

**To place an order**, contact your Graco Distributor or call to identify the nearest distributor.

**Phone:** 612-623-6921 **or Toll Free:** 1-800-328-0211 **Fax:** 612-378-3505

All written and visual data contained in this document reflects the latest product information available at the time of publication.

Graco reserves the right to make changes at any time without notice.

Original Instructions. This manual contains English. MM 334188

**Graco Headquarters:** Minneapolis

**International Offices:** Belgium, China, Japan, Korea

**GRACO INC. AND SUBSIDIARIES • P.O. BOX 1441 • MINNEAPOLIS MN 55440-1441 • USA**  
**Copyright 2015, Graco Inc. All Graco manufacturing locations are registered to ISO 9001.**

[www.graco.com](http://www.graco.com)  
Revision G, March 2018