

Maxi-Flo® Pump Package

DESCRIPTION

Designed for machinery requiring oil lubrication, this self-contained, easy-to-install package includes a reservoir, electric-motor-driven positive displacement pump, gear motor, and a choice of two control systems with a low-level switch as standard equipment.

Optional accessories are a pressure gauge and a high pressure switch which, when used with MS or MJ series type divider valves, provide an economical means of effectively monitoring system operation.

Note: Designing information for a Maxi-Flo system is available in Bulletin No. L23110.



Compact Pump / Control Package for automatic, low-pressure, centralized oil lubrication systems.

FEATURES / BENEFITS

- Choice of (1) Solid-State Time Control, or (2) Remote Control matches unit to application.
- Easy installation. Just four mounting bolts and one electrical connection.
- Transparent reservoir provides visual indication of oil level.
- Manual run push-button simplifies line filling, system bleeding or purging, and/or testing system integrity.
- Housing and reservoir are durable molded plastic.
- Lights indicate low level, operating and power on.

SPECIFICATIONS	
Pump Output per Stroke	0.010 in ³ (0.165 cm ³)
Pump Output per min of On-Time	
12 rpm @ 60 Hz	0.120 in ³ (1.97 cm ³)
10 rpm @ 50 Hz	0.100 in ³ (1.64 cm ³)
Max System Operating Pressure	500 psi (34 bar)
Atmosphere Relief Indicator Rating	600 psi (41 bar)
Lubricant	Oil, 60-30000 SUS
Operating Temperature	
Min	0°F (-18°C)
Max - Intermittent Operation	140°F (60°C), 50% duty cycle or less)
Max - Continuous Operation	120°F (49°C)
Reservoir Capacity	4 pints (1.9 liters), 116 in ³ (1890 cm ³)
Pump Gearmotors	115V, 50/60 Hz, shaded pole, 12 rpm output @ 60 Hz, 10 rpm @ 50 Hz, 0.13 amp running current, 0.185 amp inrush current
Reservoir Low Level Switch	115 VAC, 10 Watt Load

Standard Control Systems	
Time Control	Solid State Timer, 115 VAC, 50/60 Hz, cycle time from 1/2 minute to 32 hours, adjustable On-Time of 12 sec to 13 minutes
Remote Control	NOTE: If the On-Time is set greater or equal to "Total Cycle Time" the timer will cause the pump to run continuously 115 VAC, 50/60 Hz, terminal strip for connection to machine control system
Accessories	
Pressure Gauge	0-1000 psi (0-69 bar), back mount, 1/8 NPTF
High Pressure Switch	Factory set @ 550 psi (38 bar), 10 ampere contact rating @ 115 VAC

OPERATION

The pump gearmotor, energized by one of the three control units, rotates an eccentric (A) connected to a rod that drives the pump piston (B).

On the prime stroke, the piston opens the inlet port (C), allowing oil from the reservoir to flow into the piston chamber. On the power stroke, the piston motion closes the inlet port and forces

the oil through the spring-loaded check valve (D) and the outlet port (E), and into the line to the divider valves. When "On", the pump gearmotor rotates the eccentric at a fixed speed of one pump strokes every 5 seconds on 60 hz, or one stroke every 6 seconds on 50 hz. The piston meters a fixed .010 in³ (0.16 cm³) of oil for every pump stroke. The total volume of oil delivered to the system is determined by the frequency and length of "ON TIME" that the pump is operated.

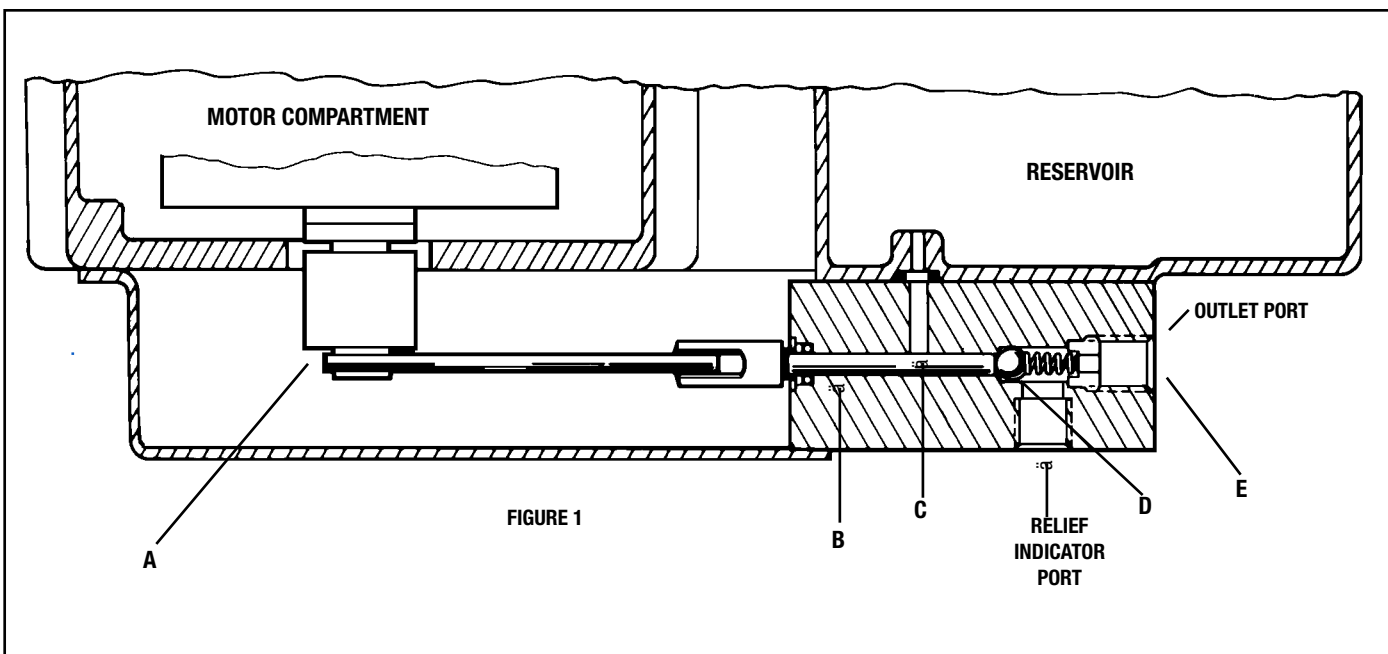

OPERATION WITH TIME CONTROL

Set the slide switch to either minutes or hours for cycle time. Next, set the desired pump "ON TIME" using a screwdriver in the slotted head of the scale marked "ON TIME MINUTES". Then in a similar fashion, set the specific interval at which lube cycles are to occur using the appropriate scale under "TOTAL CYCLE TIME".

"ON TIME" in minutes = Total output required per cycle time (cu. in.) divided by 0.12 (60 hz) or 0.10 (50 hz) cu.in. per minute output rate.

When power is applied, the timer activates the lube pump motor and simultaneously begins timing of the "ON TIME" and "TOTAL CYCLE TIME".

When the "ON TIME" is completed, the timer shuts off the pump motor but continues timing the "TOTAL CYCLE TIME" until the next cycle and "ON TIME".

Activation of the manual run button resets the cycle time to zero and starts a lube cycle.

The pump will stroke once every 5 seconds at 60 hz and once every 6 seconds at 50 hz of "ON TIME".

Note: If the "ON TIME" is greater than the "TOTAL CYCLE TIME", the timer will cause the pump to run continuously.

OPERATION WITH REMOTE CONTROL

This unit permits connection of the pump motor to the lubricated machine's control system, or to some other control system.

The pump motor "ON TIME" will be determined by the machine or external system control. For most applications, it is recommended that the pump operate a minimum of one stroke per lubrication cycle.

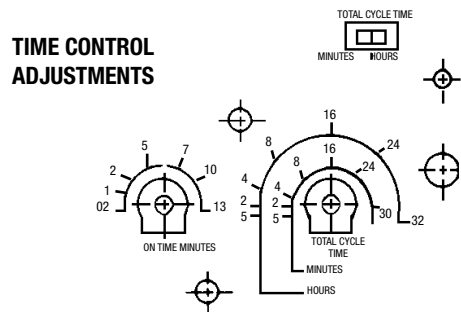

TIME CONTROL WIRING

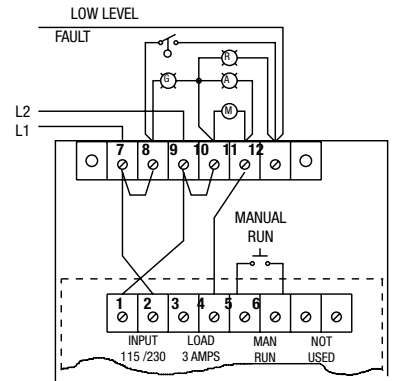

REMOTE CONTROL WIRING

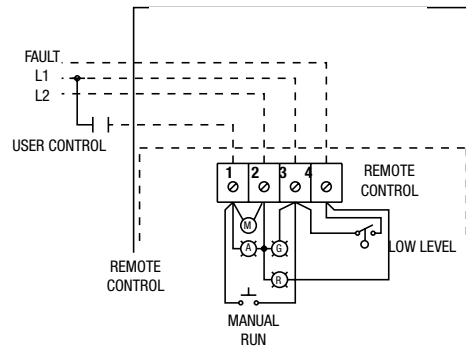

DETAIL ON STANDARD AND OPTIONAL SWITCHES

SINGLE POLE SINGLE THROW

SW RATINGS - MAX RES. LOAD			
WATTS	VOLTS	AMPS AC	AMPS DC
10	0-50	.2	0.05
	120	.08	0.02
	240	.04	N.A.

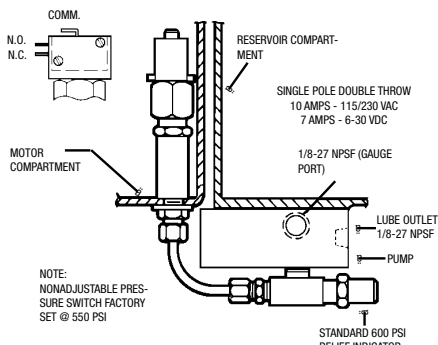

OPTIONAL HIGH PRESSURE SWITCH

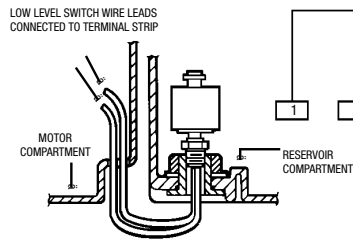

**LOW LEVEL SWITCH
SPST N.C. (Held Open)**

HIGH PRESSURE SWITCH WIRING

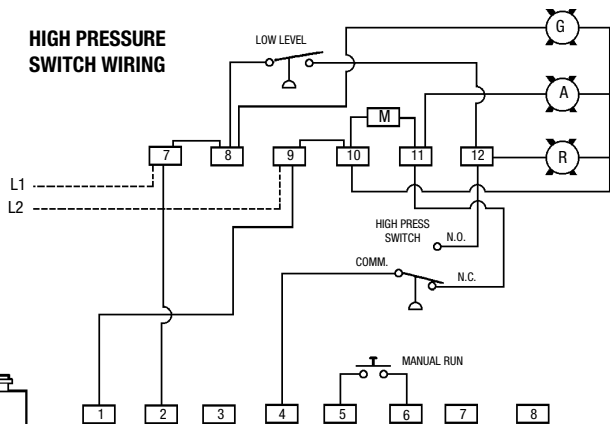

- When installing optional high pressure switch, remove factory jumper #4 to #11.
- During normal operation, pressure switch N.C. contact is closed and pump motor will operate when timer calls for a lube cycle (red fault light off).
- High pressure condition causes switch contacts to transfer interrupting power to pump motor and applying power to red fault light and fault output (red fault light on).

DIMENSIONS Inches (mm)

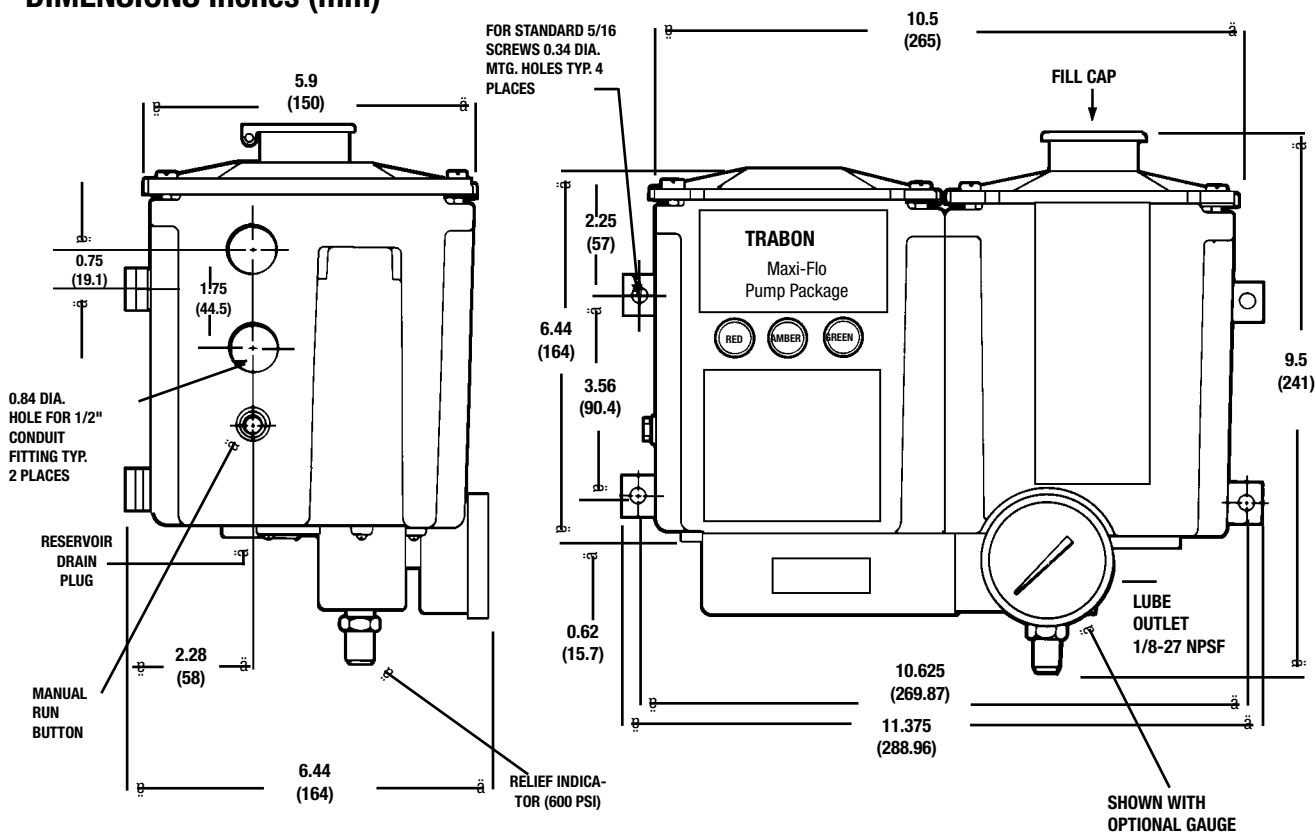

GENERAL INSTRUCTIONS

Maximum pump pressure is 500 psi. Damage may result if pump is operated in excess of 600 psi. Relief valve automatically relieves output to atmosphere at 600 psi.

Fill reservoir with clean, filtered oil - never allow pump to operate on an empty reservoir.

To drain reservoir, remove the rubber plug at the bottom extreme right hand end of reservoir.

Maxi-Flo pump should be cleaned with a mild detergent.

Do not use more than 20 inch pounds of torque on the pump mounting bolts.

Note: The Maxi-Flo package was not designed for use in outdoor applications. Do not install unit where it will be constantly exposed to direct sunlight and water.

Graco endorses the SAE recommendation of ISO 18/14 (ISO 4406) oil cleanliness for most bearing applications. Some high speed bearing may require cleaner oil. Consult the bearing manufacturer for recommendation.

COMPONENT ORDERING

Description	Part No.	Old Part No.
Maxi-Flo Package		
w/Time Control for 115 VAC, 50/60 Hz, Matched Pump Gearmotor	563379	521-500-910
w/Remote Control for 115 VAC, 50/60 Hz, Matched Pump Gearmotor	563376	521-500-430
*Optional Accessories		
High Pressure Switch	564376	521-500-330
Gauge (0-1000psi)	558899	493-020-241
Service Parts		
Timer Replacement Board, 115 VAC	558031	572-142-590
Replacement 115 VAC Gearmotor	557641	521-500-650
Replacement Pump	563374	521-500-220
Replacement Low Level Switch	557826	541-603-002
Replacement Reservoir/Timer Housing Kit	563930	560-002-130
Replacement Relief Indicator	563375	521-500-400

* Available for field installation only. Terminal strip supplied with high pressure option kit.

All written and visual data contained in this document are based on the latest product information available at the time of publication. Graco reserves the right to make changes at any time without notice.

Contact us today!

To receive product information or talk with a Graco representative, call 800-533-9655 or visit us online at www.graco.com.

