



# SERVICE PARTS LIST

**BULLETIN NO.  
54-40-0830**

SPECIFY CATALOG NO. AND SERIAL NO. WHEN ORDERING PARTS		REVISED BULLETIN	DATE
<b>M18 FUEL™ Rear Handle Circular Saw</b>			Mar. 2022
CATALOG NO.	<b>2830-20</b>	STARTING SERIAL NO.	<b>K43A</b>
		WIRING INSTRUCTION <b>See Page Three</b>	

**EXAMPLE:**  
Component Parts (Small #)  
Are Included When Ordering  
The Assembly (Large #).

**SEE PAGE 2 FOR SERVICE  
NOTES AND LUBRICATION  
OF THIS TOOL**

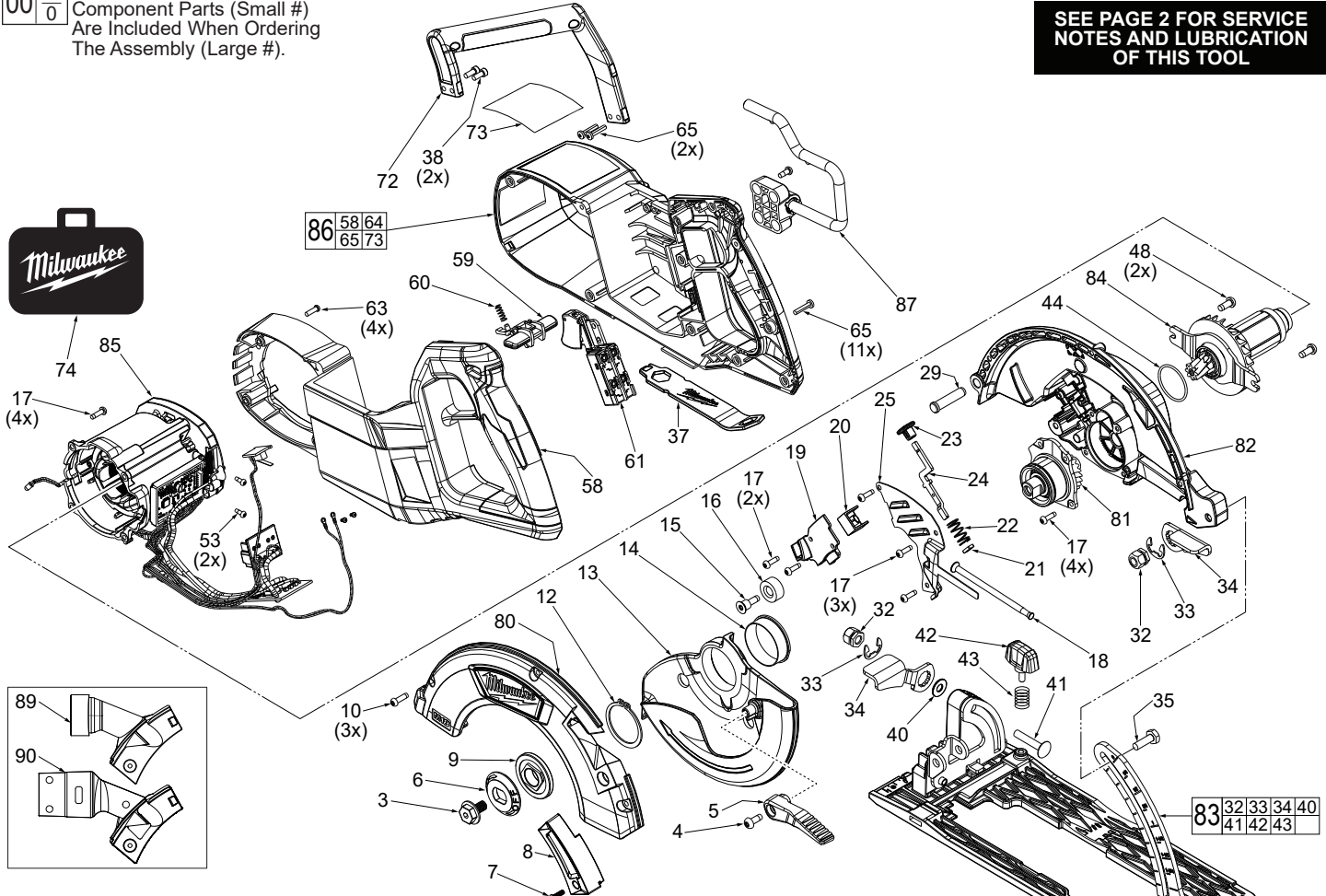
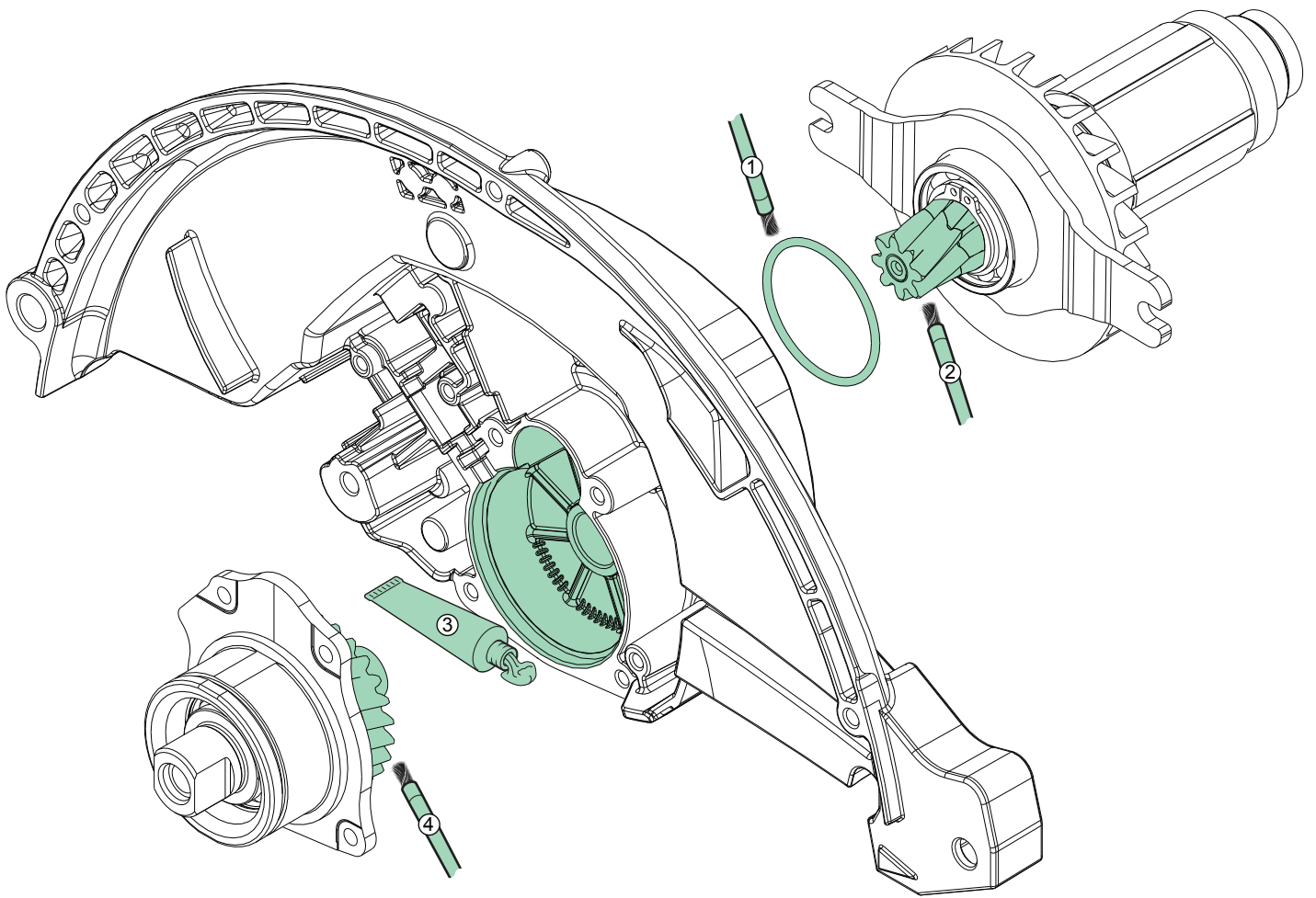

FIG.	PART NO.	DESCRIPTION OF PART	NO. REQ.
3	06-75-1010	Left Hand Blade Screw	(1)
4	06-82-5314	10-24 x1/2 Pan Hd. Taptite T-25 Screw	(1)
5	44-10-1080	Lower Guard Lever	(1)
6	43-34-0426	Outer Blade Flange	(1)
7	05-78-1005	M3.5 x 12mm Pan Hd. Phillips Machine Screw	(1)
8	31-15-0002	Dust Chute	(1)
9	43-34-0427	Inner Blade Flange	(1)
10	05-78-5316	M4 x 14mm Pan Hd. Taptite T-20 Screw	(3)
12	34-60-0860	Retaining Ring	(1)
13	28-41-0102	Lower Guard	(1)
14	45-14-0015	Sleeve Ring	(1)
15	45-04-0485	Bumper Screw	(1)
16	42-38-0224	Rubber Bumper	(1)
17	06-82-5285	6-32 x 1/2 Pan Hd. Taptite T-15 Screw	(13)
18	40-50-0045	Lower Guard Spring	(1)
19	44-66-6310	LED Cover	(1)
20	22-09-2610	LED Assembly	(1)
21	45-06-0720	Felt Seal	(1)
22	40-50-8046	Spindle Lock Spring	(1)
23	42-42-1030	Spindle Lock Button	(1)
24	44-20-1105	Spindle Lock	(1)
25	44-66-6315	Exhaust Plate	(1)
29	44-60-0741	Pivot Pin	(1)
32	05-59-2045	Drive Nut	(2)
33	42-70-0140	Bowed E-Ring	(2)
34	44-10-1085	Depth Adjustment Lever	(2)
35	05-85-0056	M6 x 19mm Hex Head Machine Screw	(1)
37	49-96-0190	Wrench	(1)
38	05-74-0986	M4 x 10mm Cap Hd. T-20 Screw	(2)
39	-----	Shoe	(1)
40	45-88-0136	Washer	(1)
41	06-10-0025	M6 x 33mm Pan Hd. Bevel Screw	(1)

FIG.	PART NO.	DESCRIPTION OF PART	NO. REQ.
42	43-98-0605	Rip Fence Knob	(1)
43	40-50-0650	Spring	(1)
44	34-40-8001	O-Ring	(1)
48	05-74-1030	M5 x 12mm Pan Hd. Taptite T-25 Screw	(2)
53	05-81-1195	M3 x 8mm Pan Hd. ST T-10 Screw	(2)
56	22-56-0005	Close End Connector	(1)
57	06-95-6215	M5 x 14mm Pan Hd. Plastite T-20 Screw	(3)
58	-----	Handle Support- Left Side	(1)
59	42-42-0345	Lock-Out Button	(1)
60	40-50-1760	Spring	(1)
61	23-66-5027	On-Off Switch	(1)
63	05-78-1010	M3.5 x 12mm Pan Hd. T-10 Machine Screw	(4)
64	-----	Handle Cover - Right Side	(1)
65	06-82-7470	#6-19 x 11/16 Pan Hd. Plastite T-15 Screw	(13)
72	31-44-0005	Top Handle	(1)
73	12-20-2830	Service Nameplate	(1)
74	42-55-6150	Contractor Bag	(1)
80	28-20-0028	Upper Guard Cover Assembly	(1)
81	38-50-0305	Output Shaft Assembly	(1)
82	28-14-1825	Upper Guard Gearcase	(1)
83	14-74-0305	Shoe Assembly	(1)
84	16-01-2820	Rotor Assembly	(1)
85	14-20-0259	Electronics Assembly	(1)
86	14-38-0580	Handle/Housing Assembly	(1)
87	14-34-7010	Rafter Hook Assembly	(1)
88	10-20-2953	Warning Label (Not Shown)	(1)
89	49-90-2065	Dust Adaptor (Standard Equipment)	(1)
90	49-90-2070	Dust Adaptor (Optional)	(1)



● **LUBRICATION NOTES:**

**Type 'J' Grease**

**No. 49-08-4220, 1 lb. can**

When servicing gears or Gear Case, 90-95% of the old grease must be removed prior to new grease being added. Clean gear assemblies with a clean, dry cloth.

- ① Brush a light coating of grease to the O-ring.
- ② Brush grease on the rotor pinion being sure to cover all the teeth.
- ③ Place approximately 6.25 grams of grease on the gearcase, before assemble output shaft assembly.
- ④ Brush a light coating of grease to the entire shaft of spindle assembly and gear teeth.

