

# ProBell<sup>®</sup> Rotary Applicator, Hollow Wrist Style

334626G

EN

*For electrostatic finishing and coating applications in Class I, Div. I hazardous locations or Group II, Zone 1 explosive atmospheres, using the following materials:*

## Solventborne Models:

- Group D materials.
- Group IIA materials.

## Waterborne Models:

**Conductive waterborne fluids that meet at least one of the following conditions for non-flammability:**

- **Material does not sustain burning in accordance with the Standard Test Method for Sustained Burning of Liquid Mixtures, ASTM D4206.**
- **Material is classified as non-ignitable or hard to ignite as defined by EN 50176.**

*For professional use only.*

*100 psi (0.7 MPa, 7.0 bar) Maximum Air Inlet Pressure  
150 psi (1.03 MPa, 10.3 bar) Maximum Fluid Working Pressure*



## Important Safety Instructions

This equipment could present hazards if not operated according to the information in this manual. Read all warnings and instructions in this manual and in all ProBell component manuals. Save all instructions.

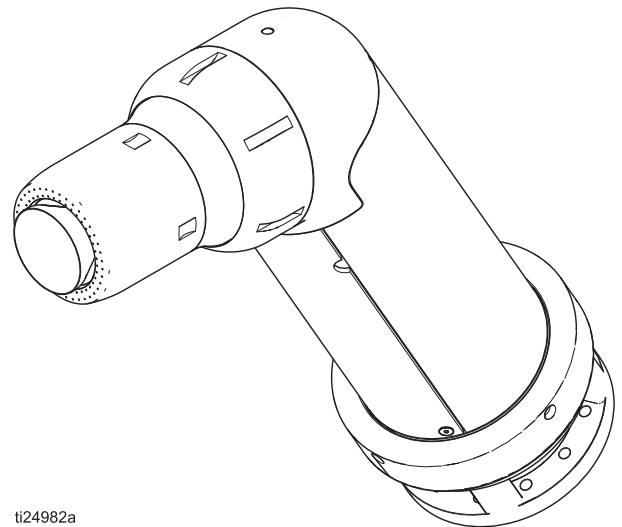

ti24982a

# Table of Contents

<b>Related Manuals</b> .....	<b>3</b>	Applicator Operation Troubleshooting .....	48
<b>Part Number Matrix</b> .....	<b>3</b>	Electrical Troubleshooting .....	50
<b>Available Models</b> .....	<b>4</b>	Waterborne System Voltage Loss Troubleshooting .....	51
<b>Approvals</b> .....	<b>4</b>	<b>Repair</b> .....	<b>53</b>
<b>Warnings</b> .....	<b>5</b>	Prepare for Service .....	53
<b>Introduction</b> .....	<b>8</b>	Prepare for Cup or Air Cap Service .....	53
System Description .....	8	Prepare for Applicator Service .....	53
<b>Installation</b> .....	<b>10</b>	Replace Cup or Air Cap .....	54
Basic Guidelines .....	10	Service the Cup and Air Cap .....	55
Typical System Installation .....	11	Replace Front Housing and Turbine Assembly ..	59
Overview of Installation Steps .....	13	Repair or Replace the Solvent Stud .....	60
Step 1. Connect All Lines at the Applicator ....	13	Repair Fluid Nozzle .....	60
Connection Schematic .....	17	Repair or Replace the Fluid Tube .....	61
Step 2. Mount the Rotary Applicator .....	18	Replace Magnetic Pickup Sensor or Fiber Optic Extension Cable .....	61
Step 3. Mount Controllers and Accessories ....	19	Replace Fluid Valves and Seats .....	62
Step 4. Connect the Fluid Supply .....	21	Replace a Fluid or Air Fitting .....	63
Step 5. Connect the Air Lines .....	25	Replace the Power Supply .....	66
Step 6. Connect Power and Communication Cables .....	29	Replace Coiled Fluid Tubes or Waterborne Fluid Tube Housing .....	68
Step 7. Prepare the Spray Area .....	31	<b>Parts</b> .....	<b>69</b>
Step 8. Create Required System Interlocks ....	31	Solventborne Models (R_A2_0) .....	69
Step 9. Ground the Equipment .....	32	Waterborne Models (R_A2_8) .....	72
Check Electrical Grounding .....	33	<b>Repair Kits</b> .....	<b>75</b>
System Logic Controller Setup .....	35	Main Housing Repair Kits .....	75
Verification .....	35	O-Ring Kits .....	75
<b>Operation</b> .....	<b>36</b>	Fittings and Tools .....	76
Pre-Operation Checklist .....	36	Air Cap and Cover Sets .....	76
Check Fluid Resistivity .....	37	Cup Selection Charts .....	77
Check Fluid Viscosity .....	37	<b>Accessories</b> .....	<b>78</b>
Spray Procedures .....	37	Fiber Optic Bulkhead Installation .....	78
Pressure Relief Procedure .....	40	<b>Dimensions</b> .....	<b>82</b>
Voltage Discharge and Grounding Procedure ..	40	<b>Performance Charts</b> .....	<b>83</b>
Shutdown .....	41	Turbine Air Consumption Charts .....	83
<b>Maintenance</b> .....	<b>42</b>	Turbine Inlet Air Pressure Charts .....	84
Daily Care and Cleaning Checklist .....	42	Shaping Air Consumption Charts .....	86
Check for Fluid Leakage .....	42	Fluid Flow Rate Charts .....	88
Electrical Tests .....	43	Pressure Loss Charts .....	91
Test Power Supply in Main Housing .....	44	<b>Technical Specifications</b> .....	<b>93</b>
Clean the Air Cap and Cup .....	46	<b>Graco Standard Warranty</b> .....	<b>94</b>
Clean the Fluid Nozzle .....	47	<b>Graco Information</b> .....	<b>94</b>
Clean the Outside of the Rotary Applicator ....	47		
<b>Troubleshooting</b> .....	<b>48</b>		
Spray Pattern Troubleshooting .....	48		

## Related Manuals

Manual	Description
334452	ProBell® Rotary Applicator
3A3657	ProBell® Electrostatic Controller
3A3953	ProBell® Speed Controller
3A3954	ProBell® Air Controller
3A3955	ProBell® System Logic Controller
3A4232	ProBell® Cart Systems
3A4346	ProBell® Hose Bundle
3A4384	ProBell® System CGM Installation Kit
3A4738	ProBell® Reflective Speed Sensor Kit

## Part Number Matrix

Check the identification plate (ID) for the part number of your applicator. The following matrix defines the components of your applicator based on the 6-digit part number.

### Sample Part Number

<b>R1A</b>	<b>2</b>	<b>3</b>	<b>0</b>
15 mm Cup	ProBell Hollow Wrist Applicator	0.75 mm nozzle	Solventborne

Cup Size		Description and Mounting Style		Nozzle Size		Fluid Type	
<b>R1A</b>	15 mm	<b>1</b>	ProBell Rotary Standard Applicator - Stationary, Reciprocator, or Solid-Wrist Robot. <i>See Manual 334452.</i>	<b>3</b>	0.75 mm	<b>0</b>	Solventborne
<b>R3A</b>	30 mm	<b>4</b>		1.0 mm	<b>8</b>	Waterborne	
<b>R5A</b>	50 mm	<b>2</b>	ProBell Rotary Applicator - Hollow Wrist, 60° Robot Mount.	<b>5</b>	1.25 mm		
				<b>6</b>	1.5 mm		

# Available Models

Part No.	Cup Size*			Nozzle Size				Fluid Type		Maximum Output Voltage
	50 mm	30 mm	15 mm	0.75 mm	1.0 mm	1.25 mm	1.5 mm	Solventborne	Waterborne	
R5A240	✓				✓			✓		100 kV
R5A250	✓					✓		✓		100 kV
R5A260	✓						✓	✓		100 kV
R5A248	✓				✓				✓	60 kV
R5A258	✓					✓			✓	60 kV
R5A268	✓						✓		✓	60 kV
R3A230		✓		✓				✓		100 kV
R3A240		✓			✓			✓		100 kV
R3A250		✓				✓		✓		100 kV
R3A260		✓					✓	✓		100 kV
R3A238		✓		✓					✓	60 kV
R3A248		✓			✓				✓	60 kV
R3A258		✓				✓			✓	60 kV
R3A268		✓					✓		✓	60 kV
R1A230			✓	✓				✓		100 kV
R1A240			✓		✓			✓		100 kV
R1A250			✓			✓		✓		100 kV
R1A238			✓	✓					✓	60 kV
R1A248			✓		✓				✓	60 kV
R1A258			✓			✓			✓	60 kV

\* All applicator models ship with a serrated aluminum cup. See the **Cup Selection Charts**, page 77, to see all available cups.

## Approvals



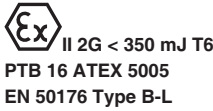

Specific controllers, rotary applicators, and power supply cables must be used together. Refer to the table below for compatible models.

Model	Electrostatic Controller	Power Supply Cables	Product Type	Applicator Approvals
RxAxx0	24Z098	17J586 17J588 17J589	Solventborne	 
RxAxx8	24Z099	17J586 17J588 17J589	Waterborne	



# Warnings

The following warnings are for the setup, use, grounding, maintenance, and repair of this equipment. The exclamation point symbol alerts you to a general warning and the hazard symbols refer to procedure-specific risks. When these symbols appear in the body of this manual or on warning labels, refer back to these Warnings. Product-specific hazard symbols and warnings not covered in this section may appear throughout the body of this manual where applicable.

 <h2 style="margin: 0;">WARNING</h2>	
   	<p><b>FIRE AND EXPLOSION HAZARD</b></p> <p>Flammable fumes, such as solvent and paint fumes, in <b>work area</b> can ignite or explode. Paint or solvent flowing through the equipment can cause static sparking. To help prevent fire and explosion:</p> <ul style="list-style-type: none"> <li>• Electrostatic equipment must be used only by trained, qualified personnel who understand the requirements of this manual.</li> <li>• Ground all equipment, personnel, object being sprayed, and conductive objects in or close to the spray area. Resistance must not exceed 1 megohm. See <b>Grounding</b> instructions.</li> <li>• Do not use pail liners unless they are conductive and grounded.</li> <li>• Always use the required arc detection settings and maintain a safe distance of at least 6 inches (152 mm) between the applicator and the workpiece.</li> <li>• <b>Stop operation immediately</b> if static sparking or repeated arc detection errors occur. Do not use equipment until you identify and correct the problem.</li> <li>• Check applicator resistance and electrical grounding daily.</li> <li>• Use and clean equipment only in well ventilated area.</li> <li>• Always turn off and discharge the electrostatics when flushing, cleaning or servicing equipment.</li> <li>• Eliminate all ignition sources; such as pilot lights, cigarettes, portable electric lamps, and plastic drop cloths (potential static sparking).</li> <li>• Do not plug or unplug power cords or turn lights on or off when flammable fumes are present.</li> <li>• Keep the spray area clean at all times. Use non-sparking tools to clean residue from the booth and hangers.</li> <li>• Keep a working fire extinguisher in the work area.</li> <li>• Interlock the applicator air and fluid supply to prevent operation unless ventilation air flow is above the minimum required value.</li> <li>• Interlock the Electrostatic Controller and fluid supply with the booth ventilation system to disable operation if the air flow falls below minimum values. Follow your local codes.</li> </ul> <p><b>For solventborne systems only:</b> Use only Group IIA or Group D materials.</p> <ul style="list-style-type: none"> <li>• Use cleaning solvents with highest possible flash point when flushing or cleaning equipment.</li> <li>• To clean the exterior of the equipment, cleaning solvents must have a flash point at least 15°C (59°F) above ambient temperature. Non-ignitable fluids are preferred.</li> </ul> <p><b>For waterborne systems only:</b> Use conductive waterborne fluids that meet at least one of the following conditions for non-flammability:</p> <ul style="list-style-type: none"> <li>• Material does not sustain burning in accordance with the Standard Test Method for Sustained Burning of Liquid Mixtures, ASTM D4206.</li> <li>• Material is classified as non-ignitable or hard to ignite as defined by EN 50176.</li> </ul>

# **WARNING**



## **ELECTRIC SHOCK HAZARD**

This equipment must be grounded. Improper grounding, setup, or usage of the system can cause electric shock.

- Turn off and disconnect power at main switch before disconnecting any cables and before servicing or installing equipment.
- Connect only to grounded power source.
- All electrical wiring must be done by a qualified electrician and comply with all local codes and regulations.

### **For waterborne systems:**









- Connect the applicator to a voltage isolation system that will discharge the system voltage when not in use.
- All components of the voltage isolation system that are charged to high voltage must be contained within an isolation enclosure that prevents personnel from making contact with the high voltage components before the system voltage is discharged.
- Follow the **Pressure Relief Procedure**, including **Voltage Discharge**, when instructed to discharge the voltage; before cleaning, flushing, or servicing the system; before approaching the front of the applicator; and before opening the isolation enclosure for the isolated fluid supply.
- Do not enter a high voltage or hazardous location until all high voltage equipment has been discharged.
- Do not touch the applicator or enter the spray area during operation. Follow the **Pressure Relief Procedure** including **Voltage Discharge**.
- Interlock the electrostatic controller with the voltage isolation system to shut off the electrostatics anytime the isolation system enclosure is opened.
- Do not splice fluid hoses together. Install only one continuous Graco Waterborne Fluid Hose between the isolated fluid supply and the applicator.



## **PRESSURIZED EQUIPMENT HAZARD**

Fluid from the equipment, leaks, or ruptured components can splash in the eyes or on skin and cause serious injury.

- Follow the **Pressure Relief Procedure** when you stop spraying/dispensing and before cleaning, checking, or servicing equipment.
- Tighten all fluid connections before operating the equipment.
- Check hoses, tubes, and couplings daily. Replace worn or damaged parts immediately.

 <h1 style="margin: 0;">WARNING</h1>	
 	<p><b>EQUIPMENT MISUSE HAZARD</b></p> <p>Misuse can cause death or serious injury.</p> <ul style="list-style-type: none"> <li>• Always operate in accordance with all information given in the instruction manuals.</li> <li>• Do not operate the unit when fatigued or under the influence of drugs or alcohol.</li> <li>• Do not exceed the maximum working pressure or temperature rating of the lowest rated system component. See <b>Technical Specifications</b> in all equipment manuals.</li> <li>• Use fluids and solvents that are compatible with equipment wetted parts. See <b>Technical Specifications</b> in all equipment manuals. Read fluid and solvent manufacturer's warnings. For complete information about your material, request Safety Data Sheet (SDS) from distributor or retailer.</li> <li>• Turn off all equipment and follow the <b>Pressure Relief Procedure</b> when equipment is not in use.</li> <li>• Check equipment daily. Repair or replace worn or damaged parts immediately with genuine manufacturer's replacement parts only.</li> <li>• Do not alter or modify equipment. Alterations or modifications may void agency approvals and create safety hazards.</li> <li>• Make sure all equipment is rated and approved for the environment in which you are using it.</li> <li>• Use equipment only for its intended purpose. Call your distributor for information.</li> <li>• Route hoses and cables away from traffic areas, sharp edges, moving parts, and hot surfaces.</li> <li>• Do not kink or over bend hoses or use hoses to pull equipment.</li> <li>• Keep children and animals away from work area.</li> <li>• Comply with all applicable safety regulations.</li> </ul>
 	<p><b>PLASTIC PARTS CLEANING SOLVENT HAZARD</b></p> <p>Many solvents can degrade plastic parts and cause them to fail, which could cause serious injury or property damage.</p> <ul style="list-style-type: none"> <li>• Use only compatible water-based solvents to clean plastic structural or pressure-containing parts.</li> <li>• See <b>Technical Specifications</b> in this and all other equipment instruction manuals. Read fluid and solvent manufacturer's Safety Data Sheet (SDS) and recommendations.</li> </ul>
 	<p><b>ENTANGLEMENT HAZARD</b></p> <p>Rotating parts can cause serious injury.</p> <ul style="list-style-type: none"> <li>• Keep clear of moving parts.</li> <li>• Do not operate equipment with protective guards or covers removed.</li> <li>• Do not wear loose clothing, jewelry or long hair while operating equipment.</li> <li>• Equipment can start without warning. Before checking, moving, or servicing equipment, follow the <b>Pressure Relief Procedure</b> and disconnect all power sources.</li> </ul>
	<p><b>TOXIC FLUID OR FUMES HAZARD</b></p> <p>Toxic fluids or fumes can cause serious injury or death if splashed in the eyes or on skin, inhaled, or swallowed.</p> <ul style="list-style-type: none"> <li>• Read Safety Data Sheet (SDS) to know the specific hazards of the fluids you are using.</li> <li>• Store hazardous fluid in approved containers, and dispose of it according to applicable guidelines.</li> </ul>
	<p><b>PERSONAL PROTECTIVE EQUIPMENT</b></p> <p>Wear appropriate protective equipment when in the work area to help prevent serious injury, including eye injury, hearing loss, inhalation of toxic fumes, and burns. Protective equipment includes but is not limited to:</p> <ul style="list-style-type: none"> <li>• Protective eyewear, and hearing protection.</li> <li>• Respirators, protective clothing, and gloves as recommended by the fluid and solvent manufacturer.</li> </ul>

# Introduction

## System Description

The ProBell Rotary Applicator is part of an electrostatic spraying system designed for industrial painting applications. The following three components are needed in all ProBell spray systems.

- Rotary Applicator
- Power Supply Cable
- Electrostatic Controller

See **Typical System Installation**, page 11, for other available system components.

### Rotary Applicator

#### Applicator Style

**The ProBell Rotary Applicator Standard style** is designed for use on a stationary mount, a reciprocator, or a solid wrist robot. It has a straight body with all connections on the rear of the applicator. See Manual 334452.

**The ProBell Rotary Applicator, Hollow Wrist style** is designed for use on a Hollow Wrist robot. The body has a 60° angle with all connections through a quick-disconnect plate. This design allows all connections to run inside the arm of the hollow wrist robot.

#### Applicator Type

**The Solventborne type** is designed for use in Class 1, Div. I Hazardous Locations using Group D spray materials, or for use in Group II, Zone 1 Explosive Atmosphere Locations using Group IIA spray materials.

**The Waterborne Type** is for use in Class 1, Div. I Hazardous Locations or in Group II, Zone 1 Explosive Atmosphere Locations with conductive waterborne fluids that meet at least one of the following conditions for non-flammability:

- Material does not sustain burning in accordance with the Standard Test Methods for Sustained Burning of Liquid Mixtures, ASTM D4206.
- Material is classified as non-ignitable or hard to ignite as defined by EN 50176.

### Power Supply Cable

The power supply cable connects the ProBell Electrostatic Controller to the power supply in the ProBell Rotary Applicator. The power supply cable is available in three lengths: 11 meters (36 ft), 20 meters (66 ft), and 30 meters (98 ft).

### ProBell Electrostatic Controller

The ProBell Electrostatic Controller (Manual 3A3657) provides the ability to display and set the voltage and current. It can operate remotely via discrete I/O or CAN communication.

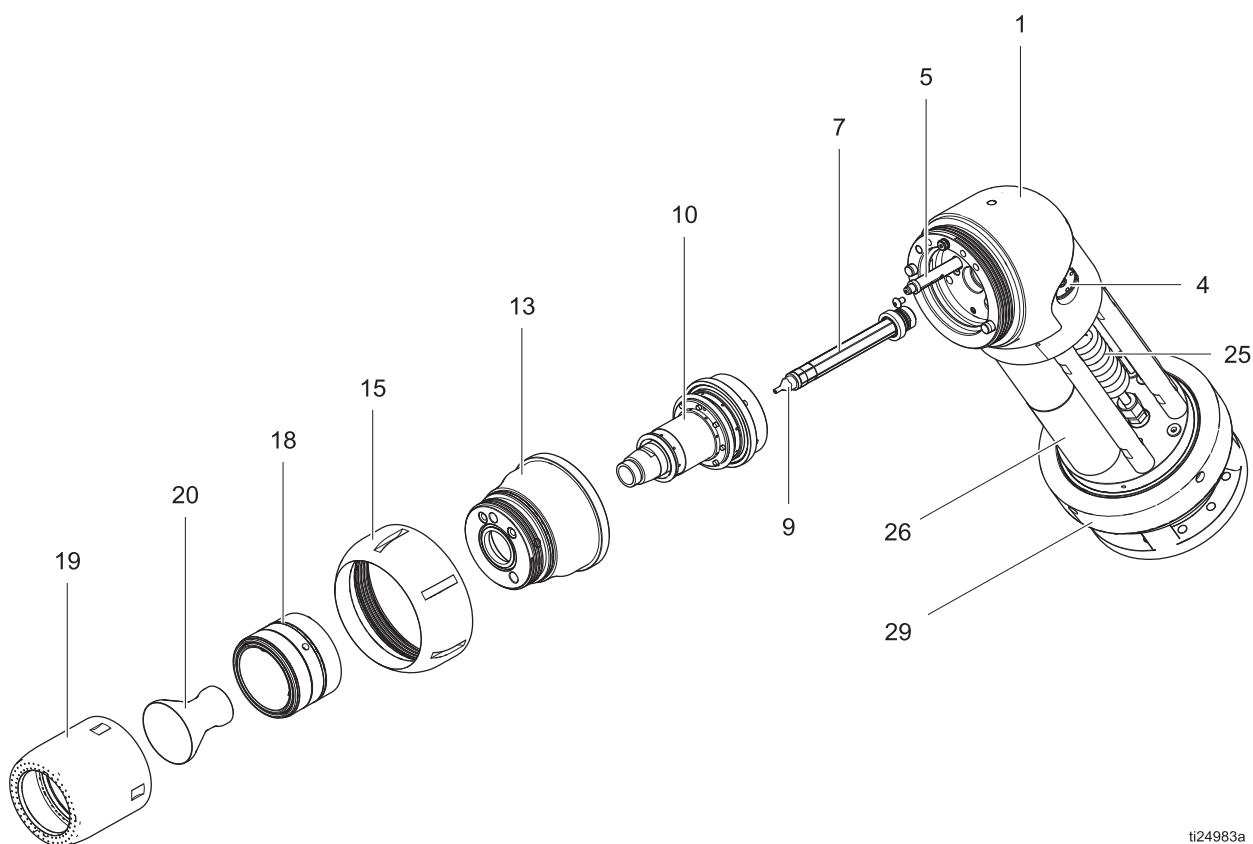

ti24983a

**FIG. 1. Rotary Atomizer Components**

Ref.	Component	Description
1, 4	Main Housing	The housings direct the air, fluid and electrical charge from the customer connections to the front of the applicator. The main housing contains three fluid valves (4).
13	Front Housing	
5	Speed Sensor Assembly	The speed sensor assembly detects the rotational speed of the magnets on the turbine assembly.
7, 9	Fluid Tube and Nozzle	The fluid nozzle contains the paint flow orifice. There are six sizes: 0.75 mm, 1.0 mm, 1.25 mm, 1.5 mm, 1.8 mm, and 2.0 mm.
10	Turbine Assembly	The turbine is driven by compressed air and provides rotating speeds up to 60,000 RPM.
15	Retaining Ring	Loosen and remove to access front-end components.
18, 19	Air Cap and Cover	The air cap and cover direct the shaping air to the correct diameter for the cup. There are three sizes of air cap components, to match the three cup sizes.

Ref.	Component	Description
20	Cup	The cup atomizes paint by rotating at speeds up to 60,000 RPM. There are three cup sizes: 15 mm, 30 mm, and 50 mm.
25	Coiled Fluid Tube	Coiled fluid tubes are installed in each applicator (3 for solvent-borne models and 1 for water-borne models). The coiled fluid tubes provide a more resistive path between the high voltage and ground for the paint, solvent, and dump lines (solvent only on water-borne models).
26	Power Supply	The power supply contains an electrostatic multiplier with 100 kV maximum output. It has a resistor built in to provide a path to discharge the applicator.
29	Quick Disconnect Ring	The quick disconnect ring is used to remove the applicator from the robot base.

# Installation



Installing and servicing this equipment requires access to parts that may cause electric shock or other serious injury if work is not performed properly.

- Do not install or service this equipment unless you are trained and qualified.
- Be sure your installation complies with National, State and Local codes for the installation of electrical apparatus in a Class I, Div. I, Group D Hazardous Location or a Group II, Zone 1 Explosive Atmosphere Location.
- If using a waterborne material, ensure that the applicator is connected to a voltage isolation system that will discharge the system voltage when required.
- Comply with all applicable local, state, and national fire, electrical, and other safety regulations.

## Basic Guidelines

### System Installation Requirements

- Several interlocks must be provided to allow safe and reliable operation. See **Step 8. Create Required System Interlocks**, page 31.
- Ventilation must be provided to prevent buildup of flammable or toxic vapors while spraying, flushing, or cleaning the applicator. See **Step 7. Prepare the Spray Area**, page 31.
- Earth grounds must be provided for all specified system components. See **Step 9. Ground the Equipment**, page 32.

### Additional Waterborne System Installation Requirements

- The applicator must be connected to a voltage isolation system that isolates the fluid supply from ground and allows voltage to be maintained at the front of the applicator.
- The applicator must be connected to a voltage isolation system with a bleed resistor that will discharge the system voltage when the applicator is not in use.
- All components of the voltage isolation system that are charged to high voltage must be contained within an isolation enclosure that prevents personnel from making contact with the high voltage components before the system voltage is discharged.
- The controller must be interlocked with the voltage isolation system to shut off and discharge the electrostatics anytime the isolation enclosure is opened or entered. See **Step 8. Create Required System Interlocks**, page 31.
- The voltage isolation system must be interlocked with the spray location entrance to automatically discharge the voltage and ground the fluid whenever someone opens the isolation enclosure or enters the spray location. See **Step 8. Create Required System Interlocks**, page 31.

#### NOTICE

The system should not have severe arcing occurring when the isolation mechanism opens and closes. Severe arcing will shorten the life of the system components.

# Typical System Installation

FIG. 2 shows a typical installation. It is not an actual system design. For assistance in designing a system to suit your particular needs, contact your Graco distributor.

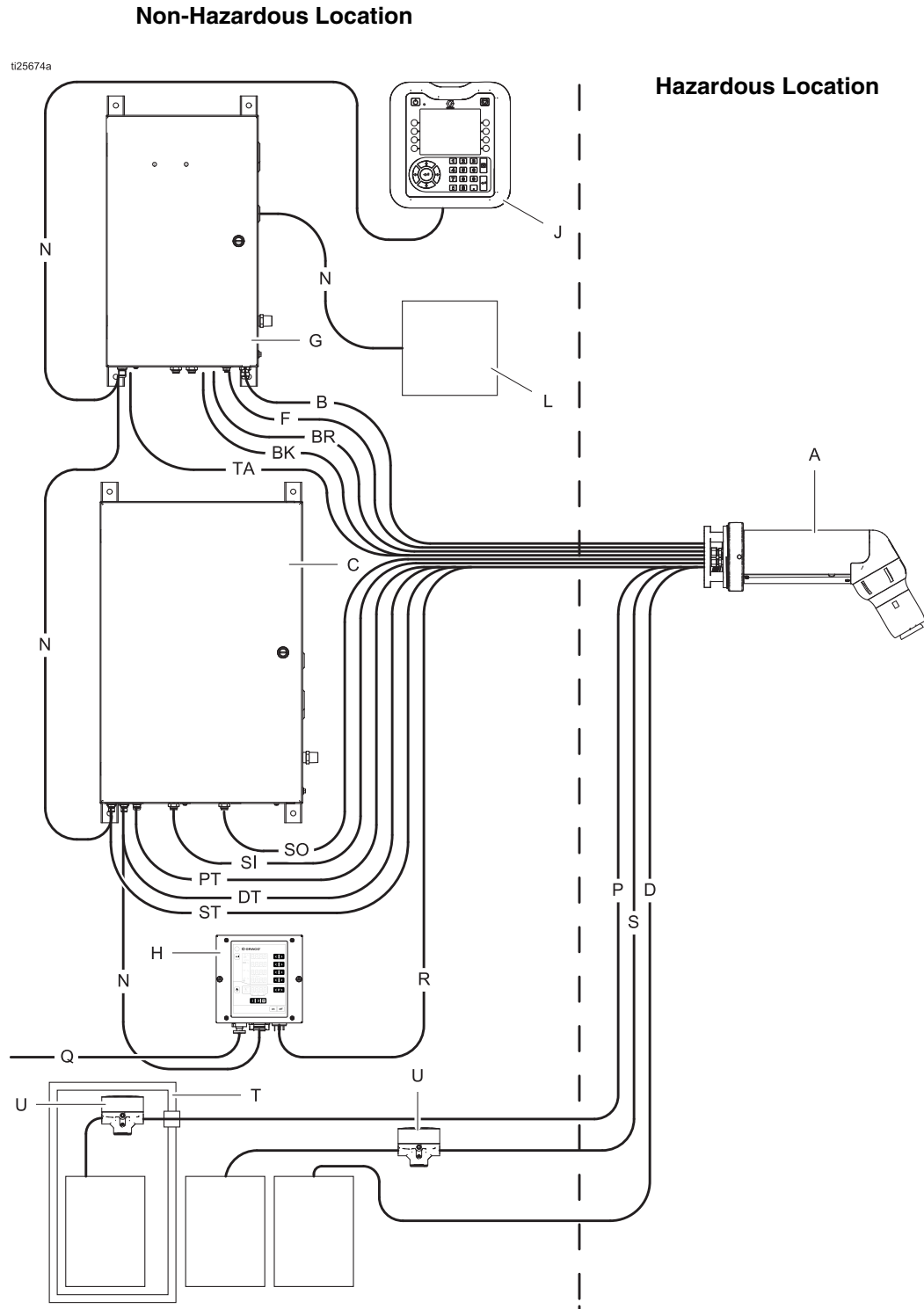

**FIG. 2. Typical Installation, Electronic Air Controller, with Fluid Isolation Box for Waterborne Systems**

Typical System Installation Components	
A	Rotary Applicator
B	Bearing Air Supply Line
BR	Bearing Air Return Line
BK	Braking Air Supply Line
C	Air Controller
D	Dump Return Line
DT	Dump Valve Trigger Air Line
F	Fiber Optic Cable For Speed Control
G	Speed Controller
H	Electrostatic Controller
J	System Logic Controller
L	PLC (connected to a gateway inside the Speed Controller)

N	CAN Communication Cables
P	Paint Supply Line
PT	Paint Valve Trigger Air Line
Q	I/O Cable (for electrostatic control and interlocks)
R	Power Supply Cable
S	Solvent Supply Line
SI	Shaping Air (Inner) Air Line
SO	Shaping Air (Outer) Air Line
ST	Solvent Valve Trigger Air Line (cup wash)
T	Fluid Supply Isolation Equipment (for water-borne applicators only)
TA	Turbine Air Line
U	Fluid Pressure Regulator

**NOTE:** See **Step 9. Ground the Equipment**, page 32, for required grounding information.



## Overview of Installation Steps

The following steps are needed to install and connect your system.

1. Connect all lines at the applicator, page 13.
2. Mount the rotary applicator, page 18.
3. Mount the controllers and accessories, page 19.
4. Connect the fluid supply, page 21.
5. Connect the air lines, page 25.
6. Connect the power and communication cables, page 29.
7. Prepare the spray area, page 31.
8. Create required system interlocks, page 31.
9. Ground the equipment, page 32.

## Step 1. Connect All Lines at the Applicator

A total of 14 connections are needed for ProBell operation.

If required, attach an adapter plate to the robot arm before connecting fluid and air lines. See **Accessories**, page 78, for a list of adapter plates.

**NOTE:** All lines must run through the robot, the robot adapter plate (if one is needed), the spacer (43), and into the robot base (38) before connection to the applicator.

**TIP:** Connect the lines in the order shown in this section. **Label each line** and **bundle into groups**, to avoid confusion later when the lines are connected to the fluid supply, air supply, and other system components.

The applicator ships assembled. Follow these steps to take the base and spacer off the applicator for easiest hose connections.

1. Use the spanner wrench tool (52) to loosen the quick disconnect ring (29). Push the ring toward the

front of the applicator. Take the robot base (38) and spacer (43) off of the applicator.

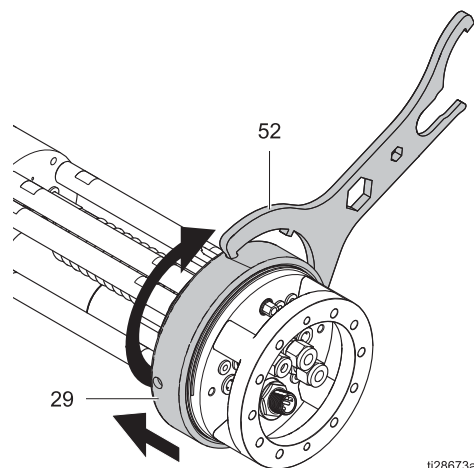



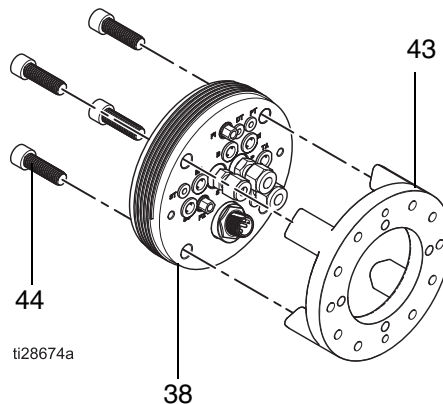

ti28673a

2. Remove four screws (44), then take the spacer (43) off of the robot base (38).



ti28674a

### Fluid Lines for Solventborne Materials

				
<p>Fluid lines may contain high-voltage fluid. Sparking due to a hose leak could cause fire, explosion, or electrical shock. To reduce the risk of sparking:</p> <ul style="list-style-type: none"> <li>• Connect all fluid lines into the grounded quick disconnect robot base.</li> <li>• Use only genuine Graco coiled fluid tubes.</li> </ul>				

All three solventborne fluid lines are connected through the robot into the robot base. The fluid then flows through coiled fluid tubes and into the main housing.

- Connect the paint supply line to port **P**.
- Connect the solvent supply line to port **S**. This port is 6 mm (1/4 in.).
- If needed, connect the fluid dump line to port **D**. If not needed, a plug kit (25C288) is available to plug the dump passage.

The paint and dump line ports are 8 mm (5/16 in.). Refer to the **Fluid Flow Rate Charts (Continued)**, page 90, to help determine the best tubing for your application.

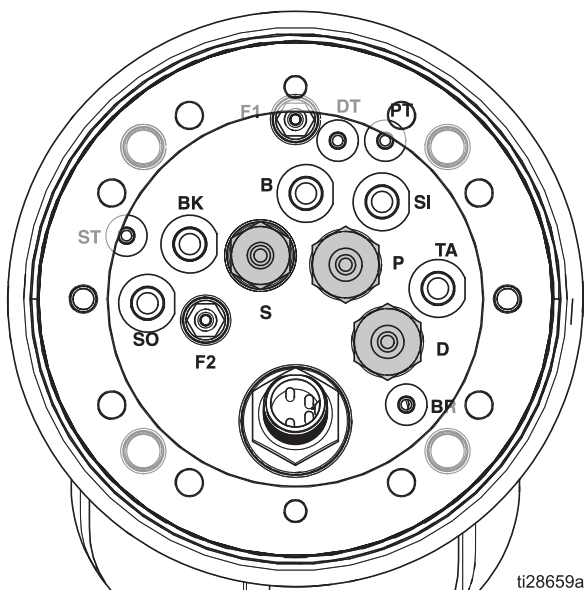





FIG. 3. Fluid Connections

### Fluid Lines for Waterborne Materials



				
<p>The fluid between the applicator and fluid supply will be charged. To reduce the risk of electric shock, use only Graco-supplied waterborne fluid hoses. See also <b>Step 9. Ground the Equipment</b>, page 32.</p>				

See **Accessories** for a list of available waterborne hoses.

Connect the solvent supply line to port **S** on the robot base. The solvent then flows through a coiled fluid tube and into the main housing. This port is 6 mm (1/4 in.).

The paint and dump line hoses pass through the robot base manifold (38) and make a fluid seal inside the hose housing (85). Install the fluid lines in the robot base according to the following directions.

- Blow out the paint supply hose and the fluid dump hose (if used) with air and flush with water before connecting.

				
<p>To reduce the risk of electric shock, install hoses to the correct height and tighten strain relief fittings securely. Improper installation height or improperly tightened strain relief fittings can cause fluid leakage.</p>				

- Pass the paint supply line through the strain relief fitting (86) marked **P** on the robot base. Pass the dump line through strain relief fitting **D** on the robot base. Position the end of each hose 7.625 in. (19.4 cm) above the manifold surface, as shown. Make sure the ferrule (87) is in place and properly oriented on the outer jacket of the hose, then tighten the strain relief nut (88) to secure each hose in place. Pull on the hoses to make sure they are firmly held by the strain relief fitting.

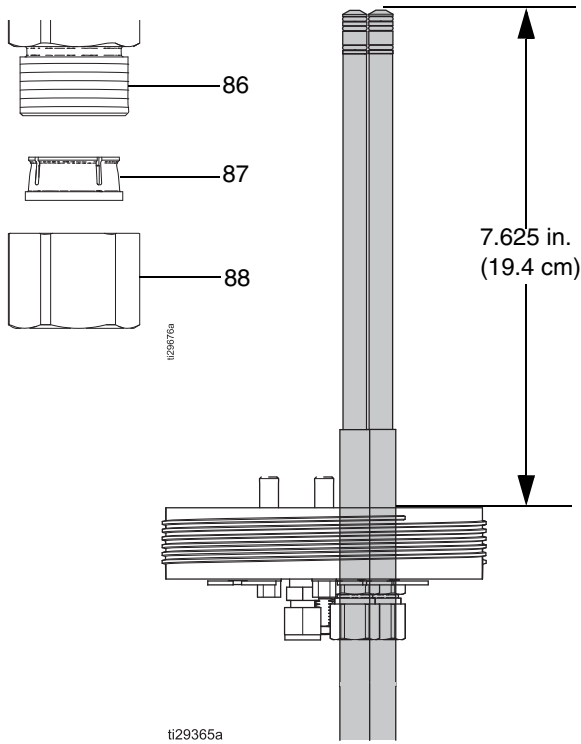

### Air Lines

A total of nine air line connections are needed. Begin at the center and work out. Remember to label each line, and bundle into groups.

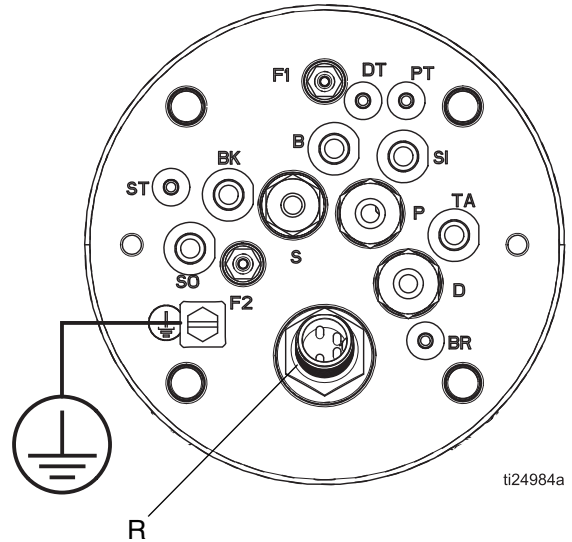

**FIG. 4. Air Connections**

3. The applicator end of the waterborne hoses come stripped to the correct dimensions. On the shielded hose the conductive layer (W) covering the PTFE tube (Y) and the outer cover (X) are trimmed to the same length. The unshielded hose has no conductive layer.

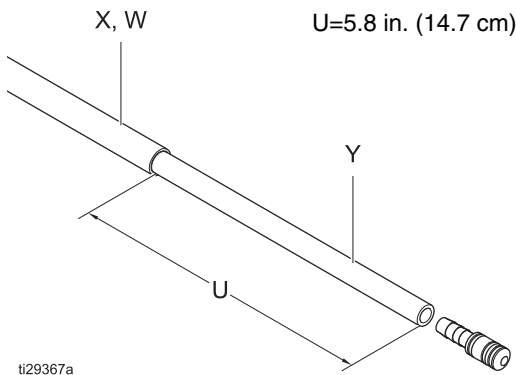

1. Connect the larger air supply lines first. Use 8 mm (5/16 in.) OD tube with 1 mm (0.04 in) wall to minimize pressure drop.
  - a. Connect the bearing air to port **B**.
  - b. Connect the inner shaping air to port **SI**.
  - c. Connect the outer shaping air to port **SO**.
  - d. Connect the turbine air to port **TA**.
  - e. Connect the braking air to port **BK**.
2. Connect the three trigger air lines next- the paint valve trigger (**PT**), the solvent valve trigger (**ST**), and the dump valve trigger (**DT**). These lines can be smaller because they provide only an air activation signal. Use 4 mm (5/32 in.) tubing.
3. Next, connect the bearing air return (**BR**), also a 4 mm (5/32 in.) tube.

## Power Supply Cable

Connect the 4-pin end of the power supply cable to connector R on the applicator.

## Fiber Optic Cable (for Optional Speed Controller)

The applicator is equipped with a magnetic pickup sensor assembly that provides a signal used by the Speed Controller. Connect a fiber optic cable to port F1 on the manifold, so that it contacts the fiber optic extension cable (64). The amount of fiber extending past the nut should be 1.48 in. (37.6 mm). See **Accessories**, page 78, for available cables.

### **NOTICE**

To avoid equipment damage, route all hoses and cables away from sharp edges. Avoid sharp bends and excessive strain on hoses or cables.

## Connect a Ground Wire

Connect a ground wire to the ground screw at the robot base. The applicator should also be grounded through its connection to the grounded robot.

## Connection Schematic

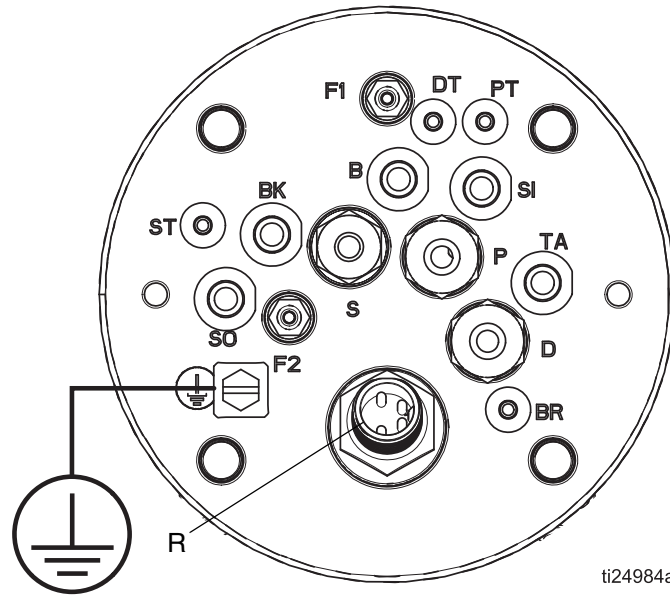

FIG. 5. Connections at the Robot Base





B	<b>Bearing Air*</b> Provides air for proper air bearing support.
BK	<b>Braking Air*</b> Slows the turbine speed.
BR	<b>Bearing Air Return</b> - 4 mm (5/32 in) tube fitting Returns air to the controller for pressure check.
D	<b>Dump Line</b> - 8 mm (5/16 in) tube fitting Waste line for flushing or color change.
DT	<b>Dump Valve Trigger</b> - 4 mm (5/32 in) tube fitting Air activation signal for the dump valve.
E	<b>Turbine Exhaust Ports</b>
F1 and F2	<b>Fiber Optic Speed Sensor Port</b>
P	<b>Paint In</b> - 8 mm (5/16 in) tube fitting Fluid supply inlet fitting

PT	<b>Paint Valve Trigger</b> - 4 mm (5/32 in) tube fitting Air activation signal for the paint valve.
R	<b>Power Supply Connection</b>
S	<b>Solvent In</b> - 6 mm (1/4 in) tube fitting Cleaning solvent supply inlet fitting
SI	<b>Shaping Air (Inner)*</b>
SO	<b>Shaping Air (Outer)*</b>
ST	<b>Solvent Trigger (Cup Wash)</b> - 4 mm (5/32 in) tube fitting Air activation signal for the solvent valve.
TA	<b>Turbine Air*†</b> Operates the turbine.

\* Use 8 mm (5/16 in) OD tube with 1 mm (0.04 in) wall to minimize pressure drop.

† The rotation speed or flow rate of a 50 mm cup may be limited due to pressure drop in the turbine air line. See **Turbine Inlet Air Pressure Charts**, page 84.

## Step 2. Mount the Rotary Applicator

				
<p>To reduce the risk of fire and explosion, all mounting hardware must be non-conductive or be properly grounded. Keep all grounded mounting hardware at least 10 in. (25.4 cm) away from the charged components.</p>				

See **Dimensions**, page 82.

If required, attach an adapter plate to the robot arm before connecting fluid and air lines. See **Accessories**, page 78, for a list of adapter plates.

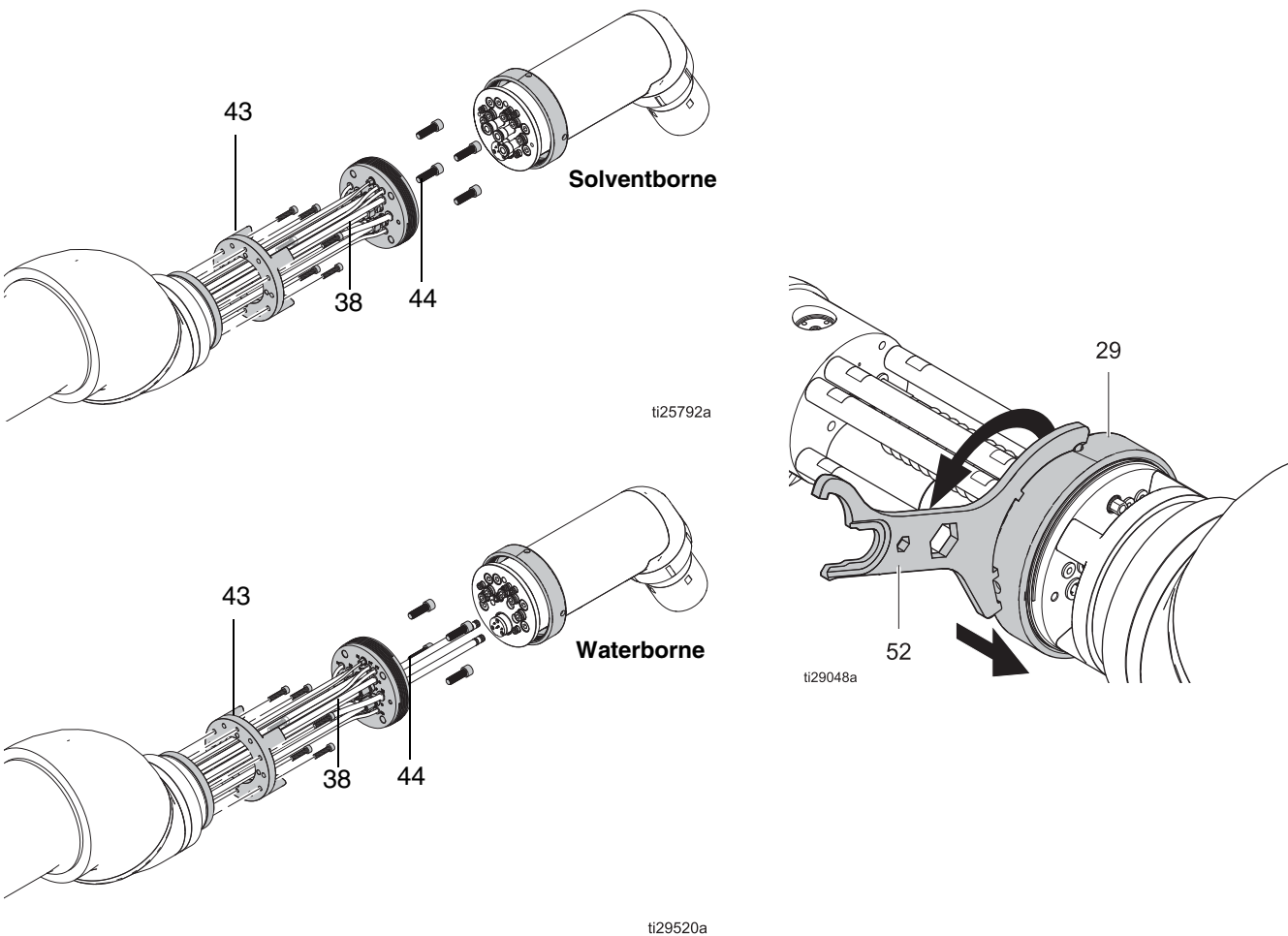

**NOTE:** Be sure each tube, line, and cable is labeled.

1. With all lines and cables connected, use appropriate screws to connect the spacer (43) securely to the robot arm or adapter plate.
2. Use screws (44) to connect the robot base (38) to the spacer (43).
3. **Waterborne applications:** Apply dielectric grease to the fluid tubes before connecting the applicator.
4. Align the applicator connections with the robot base and push the connections together. Slide the quick disconnect ring (29) into place. Tighten with the spanner wrench tool (52) to secure the applicator to the robot base.





**FIG. 6 Mount the Applicator**

### Distance to Workpiece

				
To reduce the risk of fire and explosion, maintain a Safe Distance of at least 6 in. (15.2 cm) between the applicator and the workpiece at all times.				

Position the cup a minimum of 6 in. (15.2 cm) from the closest approach point of the workpiece. Take into account potential rotation or swaying of the part. The arc detection circuitry of the Electrostatic Controller helps minimize the risk of an arc should a workpiece approach too close to the charged cup. In addition, the Safe Distance of 6 in. (15.2 cm) must be maintained at all times.

A typical spraying distance is 9-14 in. (23-36 cm).

				
To reduce the risk of fire and explosion, the spray area must remain free of rusted steel. Frictional contact between aluminum components and rusted steel must be avoided.				

### Step 3. Mount Controllers and Accessories

The following components are available to create a complete ProBell Rotary Applicator System. The ProBell controllers have been designed and optimized for use with the ProBell Rotary Applicator. Your system may use all Graco components, or a combination of Graco equipment and other controls.

				
To reduce the risk of fire and explosion, do not install equipment approved only for a non-hazardous location in a hazardous location.				

#### ProBell Electrostatic Controller (Required)

Mount the Electrostatic Controller in the non-hazardous area. See ProBell Electrostatic Controller Manual 3A3657 for installation instructions.

#### ProBell System Logic Controller

The rotary applicator system can be controlled with a System Logic Controller or with an existing PLC. A System Logic Controller is required if your system includes a ProBell Speed Controller or a ProBell Air Controller. Mount the System Logic Controller in the non-hazardous area. See Manual 3A3955 for installation instructions.

#### ProBell Speed Controller (Optional)

Mount the Speed Controller in the non-hazardous area, as close to the applicator as possible to minimize pressure loss in the air lines. See Manual 3A3953 for installation instructions.

#### ProBell Air Controller (Optional)

Graco offers two Air Controller options: Electronic and Manual. Mount the Air Controller in the non-hazardous area, as close to the applicator as possible to minimize pressure loss in the air lines. See Manual 3A3954 for installation instructions and to see features of each air controller.

#### Air Filters

<b>NOTICE</b>
Air that is not filtered to specification can clog bearing air passages and cause bearing failure. The warranty does not cover a turbine damaged by contaminated air.

Three air filtration stages are required to prevent contamination of the paint finish and to prevent damage to the air bearing. Refer to Table 1 for the specifications of each filter. Use only these recommended filters, or filters that meet the same specifications. See Manual 309919 for filter details, installation, and pipe size recommendations.

- The temperature of the air as it enters the Pre-Filter must be close to ambient.
- Air must be dehydrated to a dew point of 10°F (-12°C).

## Installation

- Filters must remove 99% of all aerosols.
- Filters must remove particles of 0.5 micron and larger. Graco filter 234403 removes particles down to 0.01 microns.
- Standard piping may be used only up to the pre-filters. All piping after the pre-filters should be brass, stainless steel, or plastic hose.
- Do not use any type of thread sealant or PTFE tape downstream of the bearing air filter. Small particles may loosen and plug the air holes in the turbine air bearings.
- Air that is heated above 120° F (49° C) will damage filter elements.

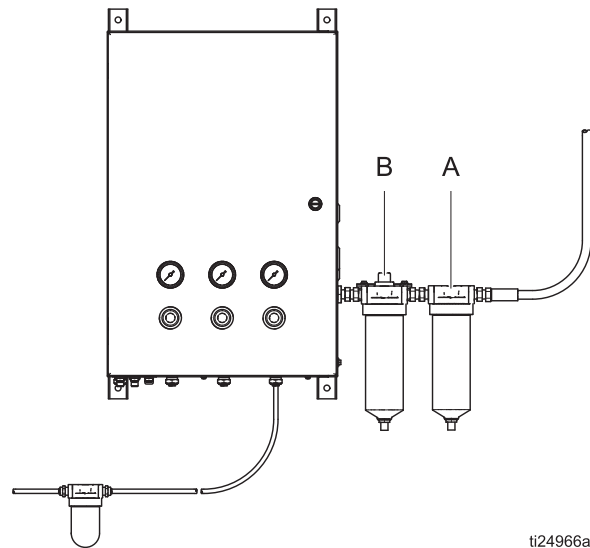

**FIG. 7. Air Filters**

**Table 1. Required Air Filters**

PN	Description and Specification	Replacement Element PN	Air Inlet and Outlet npt(f)
234402	<b>Stage 1: Pre-Filter (A)</b> 100 SCFM (rated flow of 100 SCFM minimum is required), removes coarse amounts of oil, moisture, and dirt to 3 microns. Use upstream of 234403.	16W405	1/2 in.
234403	<b>Stage 2: Grade 6 Coalescing Filter (B)</b> 50 SCFM (rated flow of 50 SCFM minimum is required), removes oil and submicronic particles down to 0.01 microns. Use one filter for each ProBell Applicator.	16W407	1/2 in.
17M754	<b>In Control Box: Bearing Air Grade 6 Coalescing Filter (C)</b> 4 SCFM (rated flow of 4 SCFM minimum is required). One filter is included in ProBell Speed Controller 24X519 and in ProBell Manual Air Controller 24X520.	Not available. Replace with assembly 17M754	1/4 in. push-lock, (m)

## Air Heaters

Air heaters may be needed in some applications. If the surface temperature of the applicator falls below the dew point of the paint booth, condensation may form on the inside or outside of the applicator. This condensation is caused by supply air that is too cool, or by the cooling of the shaping and turbine airs as they exit the applicator.

A heater may be required to ensure that the temperature of the turbine exhaust air is above the dew point of the spray booth. Install heaters into the air supply lines (turbine, shaping airs).

Set the heater as low as possible to maintain the applicator surface temperatures above the dew point in the booth.

**NOTE:** The maximum air temperature at the cup must not exceed 120°F (49°C).



## Step 4. Connect the Fluid Supply

Connect fluid lines at the applicator first. See **Step 1. Connect All Lines at the Applicator**, page 13.

### Solventborne Systems

a. **Paint Hose:** The fluid hose connected to port **P** on the applicator must be connected to a regulated, filtered paint supply, such as a circulation system or a supply pump. This hose also must be connected to a regulated solvent supply to flush the system and an air supply to empty the lines. This illustration shows a common way to make these connections.

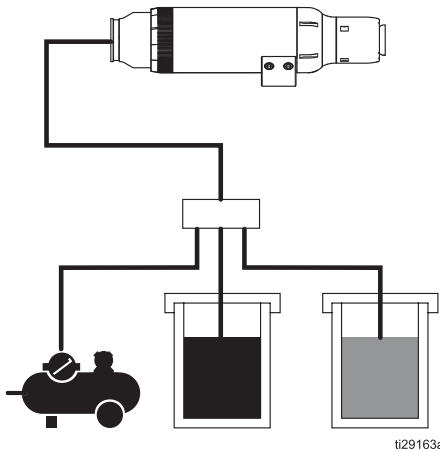

b. **Dump Hose (optional):** The fluid hose connected to port **D** on the applicator must go to a grounded waste container.

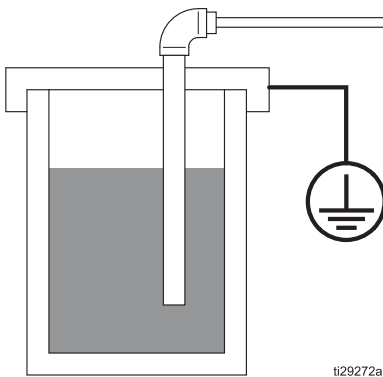

c. **Solvent Hose:** The fluid hose connected to port **S** on the applicator must be connected to a regulated solvent supply that will be used to wash the cup. This line

must also be connected to a regulated air supply to purge the cup wash passages with air.

An air purge is recommended for use with conductive solvents to improve electrostatic performance

NOTE: Not purging the lines of conductive solvents may cause low electrostatic voltage or system errors.

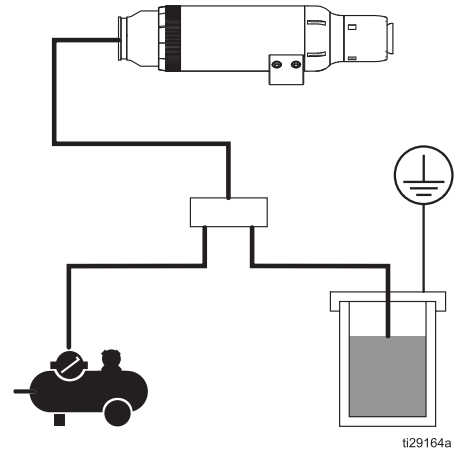

### Waterborne Systems

The fluid between the applicator and the fluid supply will be charged. To reduce the risk of electric shock, follow hose requirements and instructions carefully.				

a. **General Requirements:** Waterborne isolation systems must meet these requirements:

- Fluid Supply
  - All conductive components of the fluid supply (pump, filter, regulator, container, etc.) that are charged to high voltage must be bonded together.
  - If non-conductive containers are used, a conductive element bonded to the fluid supply must be in contact with the fluid.
- Fluid Hose
  - Use only approved Graco Waterborne fluid hoses.
  - Unshielded waterborne fluid hoses must be routed such that a minimum distance of 0.25 cm/kV is maintained between the hose and

grounded surfaces.

- The conductive layer of shielded hoses must be grounded at the isolation system.

- Enclosure

- All components of the isolated fluid supply system must be housed in a protective enclosure to prevent contact with the charged components during operation.

- Access to the enclosure must be interlocked with the high voltage supply to shut off and discharge the high voltage before any live parts can be reached.

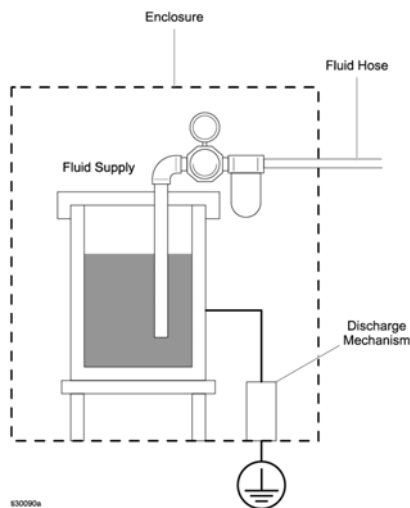

b. **Paint Hose:** The fluid hose connected to port P on the applicator must be connected to a regulated, filtered paint supply. This hose also must be connected to a regulated solvent supply to flush the system. Connect an air supply to empty the lines, if needed. The illustration below shows a common way to make these connections.

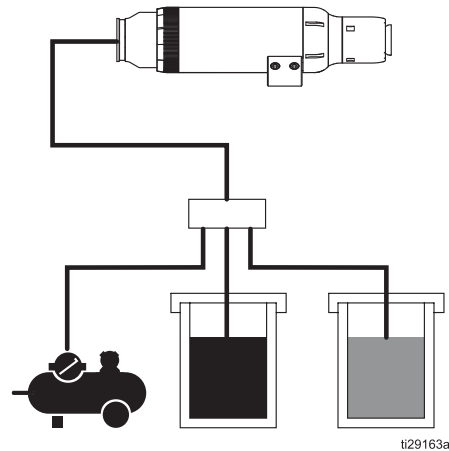

c. **Dump Hose (optional):** The most common system design for the dump line (connected to port **D**) is to connect a waterborne fluid hose to a grounded waste container. Flush and purge the dump line with air before turning on the electrostatics.

A second dump option is to place the waste container in the voltage isolation enclosure. Connect a Graco Waterborne Fluid Hose between the voltage isolation system fluid outlet and the applicator dump port (**D**).

d. **Solvent Hose:** The fluid hose connected to port S on the applicator must be connected to a grounded, regulated solvent supply that will be used to wash the cup. This line must also be connected to a regulated air supply to purge the cup wash passages with air. An air purge is required for very conductive waterborne fluids.

NOTE: Not purging the lines will cause low electrostatic voltage or system errors.

An isolated solvent kit 25N020 is also available for waterborne systems that have the solvent supply inside the isolation system.

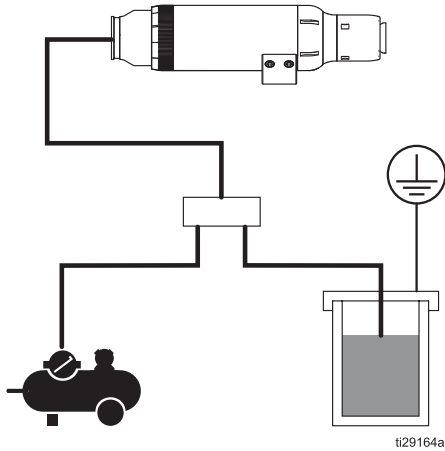

- A shielded hose consists of an inner PTFE tube (Y), a conductive layer covering the PTFE tube (W), and an outer cover (X).

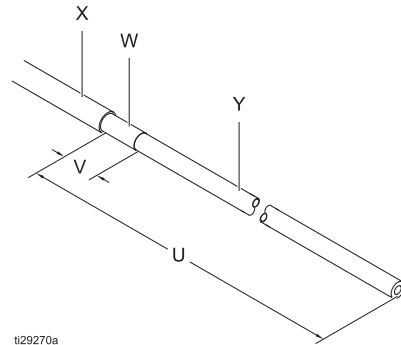

If a hose failure occurs where high voltage arcs through the inner tube, voltage will be discharged to ground through the conductive hose layer. When properly installed, the conductive hose layer is grounded through its connection to the grounded enclosure.

The fluid supply end of the hose has been stripped at the factory for connection to a WB100 Isolation System, as shown below. If desired, the hose can be changed on this end, but the conductive layer (W) must be no closer than 8 in. (20.3 cm) to the end of the hose or any other high-voltage component. See Ref. U in the illustration.

e. Waterborne Fluid Hoses

Hose-Stripping Requirements				
Ref.	Shielded		Unshielded	
U	14.5 in.	368 mm	14.5 in.	368 mm
V	0.75 in.	19 mm	NA	

- An unshielded hose consists of a PTFE tube (Y) with an outer covering (X).

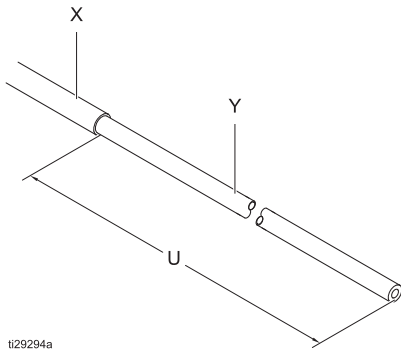

**NOTICE**

Be careful not to cut into the inner tube (Y) of the hose when stripping the hose. Nicks or cuts in the PTFE tube will cause premature hose failure.

**NOTE:** Blow out the fluid supply hose and circulation hose (if used) with air and flush with water before connecting.

- Connect one end of the hose to the applicator.
- Connect the other end to a fluid supply inside an isolation enclosure.
- Route unshielded hoses away from grounded objects. Maintain a distance of 0.25cm/kV between the hose and grounded objects.

--	--	--	--	--

To reduce the risk of electric shock, the areas of the Graco waterborne fluid hose that are accessible to personnel during normal operation must be covered by the outer hose jacket (X). The portion of the inner PTFE tube (Y) not covered by the outer jacket (X) must be inside the isolation enclosure (T). The conductive hose layer (W) must be grounded at the isolation enclosure (T).

- Connect the fluid hose(s) as follows:

1. Pass the Graco waterborne fluid hose through a strain relief fitting at the wall of the isolated enclosure and connect the inner tube (Y) to the fluid supply outlet. Tighten the strain relief fitting (Z). For a shielded hose, the conductive layer of the hose (W) must be grounded to the isolation system ground (strain relief fittings must grab onto the outer jacket or conductive layer of the fluid hose)

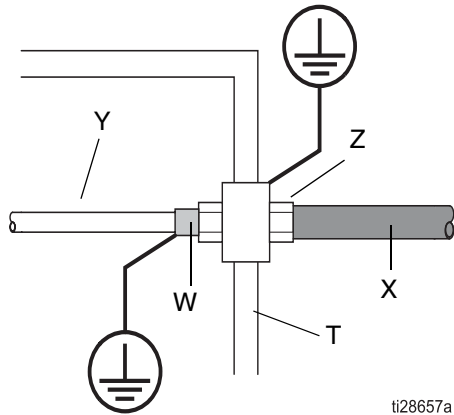

2. Using an ohmmeter, verify continuity between the conductive layer closest to the applicator and the isolation enclosure ground.

3. Connect the dump hose (D) to a grounded or isolated waste container. Connect the waterborne hose as in step 1.

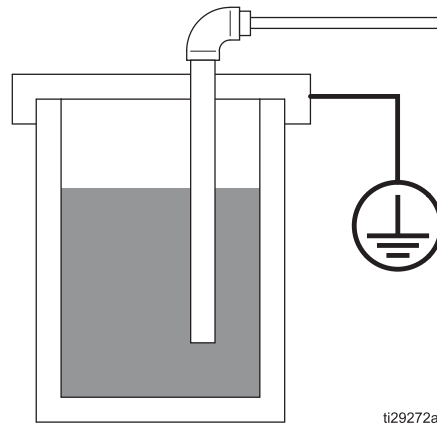

## Step 5. Connect the Air Lines

Connect all air lines to the applicator first (See **Step 1. Connect All Lines at the Applicator**, page 13). The air supply for each line can be regulated and actuated using the ProBell Speed Controller and/or one of the ProBell Air Controllers (see **Table 2: Air Line Connections Availability by Controller**, page 28). Spray parameters can be adjusted independently or saved as presets. ProBell controllers are labeled with the same reference letters as the applicator, for easier matching (see **Fig. 9** or **Fig. 10**, page 27 for more detail). See the following sections for connection information.

If your system is not using all of the ProBell controllers, see the following sections for specifications and requirements for each air line

<b>NOTICE</b>
Take great care to connect the air lines to the correct ports on the control equipment. Incorrect air line connections will damage the applicator.

### Bearing Air

<b>NOTICE</b>
To avoid equipment damage
<ul style="list-style-type: none"> <li>• Bearing air must be on while the turbine is spinning and must not be turned off until the cup comes to a complete stop.</li> <li>• Bearing air must be filtered to precise requirements. See <b>Air Filters</b>, page 19.</li> </ul>

The bearing air provides proper bearing support. Connect the bearing air line to the port marked **B** on either the Speed Controller or the Manual Air Controller if only one controller is present in the system. If both Speed Controller and Manual Air Controller are present, the connection must be made to the Speed Controller.

To provide additional protection for the bearing if the bearing air is turned off before the bell cup comes to a complete stop, install an air accumulator tank (AT) and a check valve (CV) in the bearing air line. The accumulator tank (AT) should be 3 gallons (11 liters) or greater.

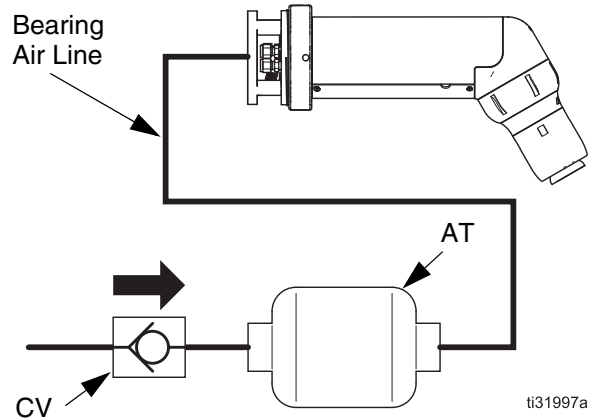

**FIG. 8 Bearing air line with accumulator tank and check valve**

Bearing air requires at least 70 psi (0.48 MPa, 4.8 bar) pressure at the applicator at all times. A flow volume of 3 scfm is required.

<b>NOTICE</b>
For best performance, maintain 100 psi (0.69 MPa, 6.9 bar) bearing air pressure. Bearing air pressure of less than 90 psi (0.62 MPa, 6.2 bar) increases the potential for turbine failure when running at speeds greater than 50 kRPM.

### Bearing Air Return

<b>NOTICE</b>
Use of a bearing air return line will help prevent equipment damage.

The bearing air return line is connected to a pressure monitoring device to ensure that adequate bearing air pressure is maintained. Connect the bearing air return line to the port marked **BR** on either the Speed Controller or the Manual Air Controller if only one controller is present in the system. If both Speed Controller and Manual Air Controller are present, the connection must be made to the Speed Controller.

If your system does not use the ProBell System Logic Controller, bearing air return must be interlocked with the turbine air so that the turbine air will not flow if the bearing air return pressure is under 70 psi (0.48 MPa, 4.8 bar).

**NOTE:** While not advisable, if you choose not to use the bearing air return line, plug the bearing air return port (BR) on the applicator.

## Turbine Air

### NOTICE

Turbine air supplies must be regulated and adjusted to the right pressure before use. Excess air flow will over speed the turbine and will result in equipment damage

The turbine air rotates the cup. Connect the turbine air line to the port marked **TA** on either the Speed Controller or the Manual Air Controller if only one controller is present in the system. If both Speed Controller and Manual Air Controller are present, the connection must be made to the Speed Controller.

For speed adjustment using a pressure regulator, see the **Turbine Inlet Air Pressure Charts** on page 84 for typical air requirements for a given rotation speed.

If your system does not use the ProBell System Logic Controller, interlock the turbine air with either the bearing air or the bearing return air, to ensure that the turbine air will flow only if the bearing air pressure is at least 70 psi (0.48 MPa, 4.8 bar).

If your system does not use the ProBell System Logic Controller, interlock the turbine air with the brake air so they cannot flow at the same time.

## Braking Air

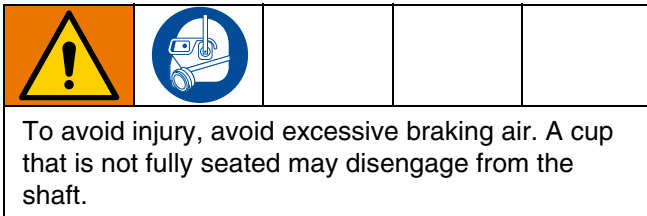

The braking air slows the turbine speed. Connect the braking air line to the port marked **BK** on the Speed Controller. The speed controller automatically engages the braking air as needed.

For manual air braking, apply 20 psi (0.14 MPa, 1.4 bar) air for approximately 5 seconds. This pressure will slow the bell speed rapidly. Adjust the air pressure and time as needed for your system to stop cup rotation.

### NOTICE

To prevent equipment damage, do not leave braking air on long enough to rotate the turbine in reverse.

If your system does not use the ProBell System Logic Controller, interlock the turbine air with the brake air so they cannot flow at the same time.

## Shaping Airs

The inner and outer shaping airs provide pattern control and keep the material particles moving toward the object being sprayed. Connect the inner shaping air line to the port marked **SI** on the Air Controller. Connect the outer shaping air line to the port marked **SO** on the Air Controller.

See the **Shaping Air Consumption Charts**, page 86, for volume requirements. Use filtered, dry air for best finish quality.

Maintain an inner shaping air pressure of at least 10 psi (0.07 MPa, 0.7 bar) at all times, to help keep the bell clean. Use both inner and outer shaping air for optimal pattern control. Adjust the pressures to achieve the best pattern for your application. Increase shaping air pressures to reduce the pattern size.

## Paint Valve Trigger

The paint valve trigger provides an air activation signal for the paint valve. Actuate the paint trigger each time a part is sprayed. The acceptable pressure range is 70-100 psi (0.48-0.69 MPa, 4.8-6.9 bar). Connect the paint valve trigger air line to the port marked **PT** on the Air Controller.

Interlock the paint trigger with the turbine air so the paint valve will not open to spray unless the turbine speed is at least 10,000 rpm. The rotation is required to prevent fluid from flooding the turbine area.

Interlock the paint trigger with the conveyor, so the paint valve will open to spray only when the conveyor is moving.

See ProBell Air Controller Manual 3A3954 for options to create these interlocks.

## Paint Trigger Input

The paint trigger input is included on the ProBell Air Controller (both manual and electronic models). This isolated input can be used to trigger the paint valve on a ProBell system from a PLC or robot. See the System Logic Controller Manual (3A3955) to configure how the paint is triggered in a ProBell system. See the ProBell Air Controller Manual (3A3954) to connect the paint trigger input.

### Solvent Valve Trigger (Cup Wash)

The solvent valve trigger provides an air activation signal for the solvent valve and is used to perform a cup wash. Connect the solvent valve trigger air line to the port marked **ST** on the Air Controller.

Interlock the solvent trigger with the turbine air so that the solvent valve will not open to spray unless the turbine speed is at least 10,000 rpm. The rotation is required to prevent fluid from flooding the turbine area.

Interlock the solvent trigger with the electrostatics so that the solvent valve will open to flow only if the electrostatics are turned off and discharged.

### Dump Valve Trigger

The dump valve trigger provides an air activation signal for the dump valve. The dump valve is used to purge the paint line. Connect the dump valve trigger air line to the port marked **DT** on the Air Controller.

### Auxiliary Ports

Three auxiliary ports are provided on the Graco Air Controllers for other customized system needs. The user might use one to trigger a valve, for example, or to connect a shutoff signal to stop the conveyor system.

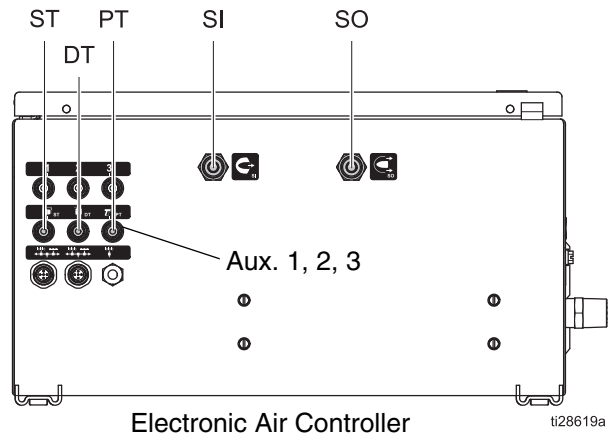
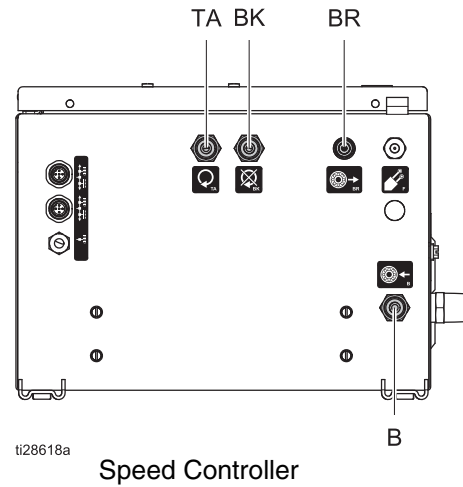



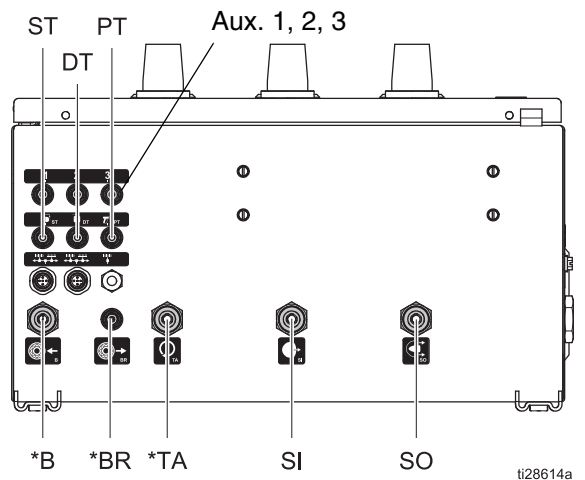





**FIG. 9 Air Connections, Electronic Air Controller with Speed Controller**



**FIG. 10. Air Connections, Manual Air Controller**

**Table 2: Air Line Connections Availability by Controller Type**

Air Line		Speed Controller Connections	Electronic Air Controller Connections	Manual Air Controller Connections
B (Bearing Air)		✓		✓
BK (Braking Air)		✓		
BR (Bearing Air Return)		✓		✓
DT (Dump Valve Trigger)			✓	✓
PT (Paint Valve Trigger)			✓	✓
SI (Shaping Air Inner)			✓	✓
SO (Shaping Air Outer)			✓	✓
ST (Solvent Trigger)			✓	✓
TA (Turbine Air)		✓		✓
Auxiliary Triggers (for system flexibility)	1, 2, 3,		✓	✓



## Step 6. Connect Power and Communication Cables

### Electrostatic Controller

1. Connect the 7-pin side of the power supply cable to connector R on the Electrostatic Controller.
2. Make **Interlock** connections. See Electrostatic Controller Manual 3A3657 for details.
  - Solvent supply
  - Spray area doors and openings
  - Conveyor
  - Ventilation fans
  - Fire control system
  - Fluid supply
  - Isolation system for waterborne materials
3. Integrate the electrostatics. Integration of the electrostatic enable function typically depends on a part detection system. Two options are common:
  - Use the electrostatic enable digital input on the Discrete I/O interface of the ProBell Electrostatic Controller. Connect per controller manual 3A3657.
  - Provide a command from an external controller to the ProBell System Logic Controller to set the electrostatic enable register via a communication network. See Manual 3A3955.

### Speed Controller

Connect the fiber optic cable to port **F** on the applicator and to port **F** on the speed controller. The amount of fiber extending past the nut should be 0.440 in. (11.2 mm) on the speed controller side. On the applicator side, the amount of extended fiber is 1.48 in. (37.6 mm). If you need to cut or repair the cable, use the tool included with the cable to cut as shown.

Speed Controller End  
0.440 in. (11.2 mm)

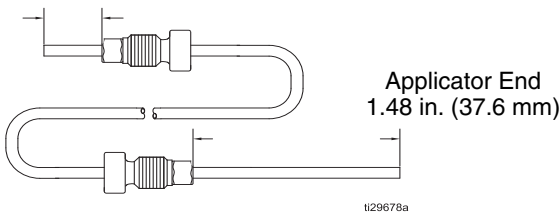

### Available Fiber Optic Cables

PN	Length
24Z193	36 ft (11 m)
24Z194	66 ft (20 m)
24Z195	99 ft (30 m)

**NOTE:** An alternate reflective speed sensing kit is available, Kit 24Z183. The kit includes instructions for conversion and installation.

### Graco CAN Communication Cables for System Components

System components communicate information via Graco CAN cables. No CAN cables connect to the applicator. But, several are needed to interconnect other system components.

Use CAN cables to network the Electrostatic Controller, Air Controller, Speed Controller, and the Graco System Logic Controller (if used) in series, as shown in the figure. One power supply is required in the CAN network, typically mounted on the speed controller. See page 78 for a list of available CAN cables.

To connect the ProBell system to an outside communication network, purchase and install a gateway (see 3A4384 *CGM Installation Kit 24Z574*) and configure per the *System Logic Controller* manual 3A3955.

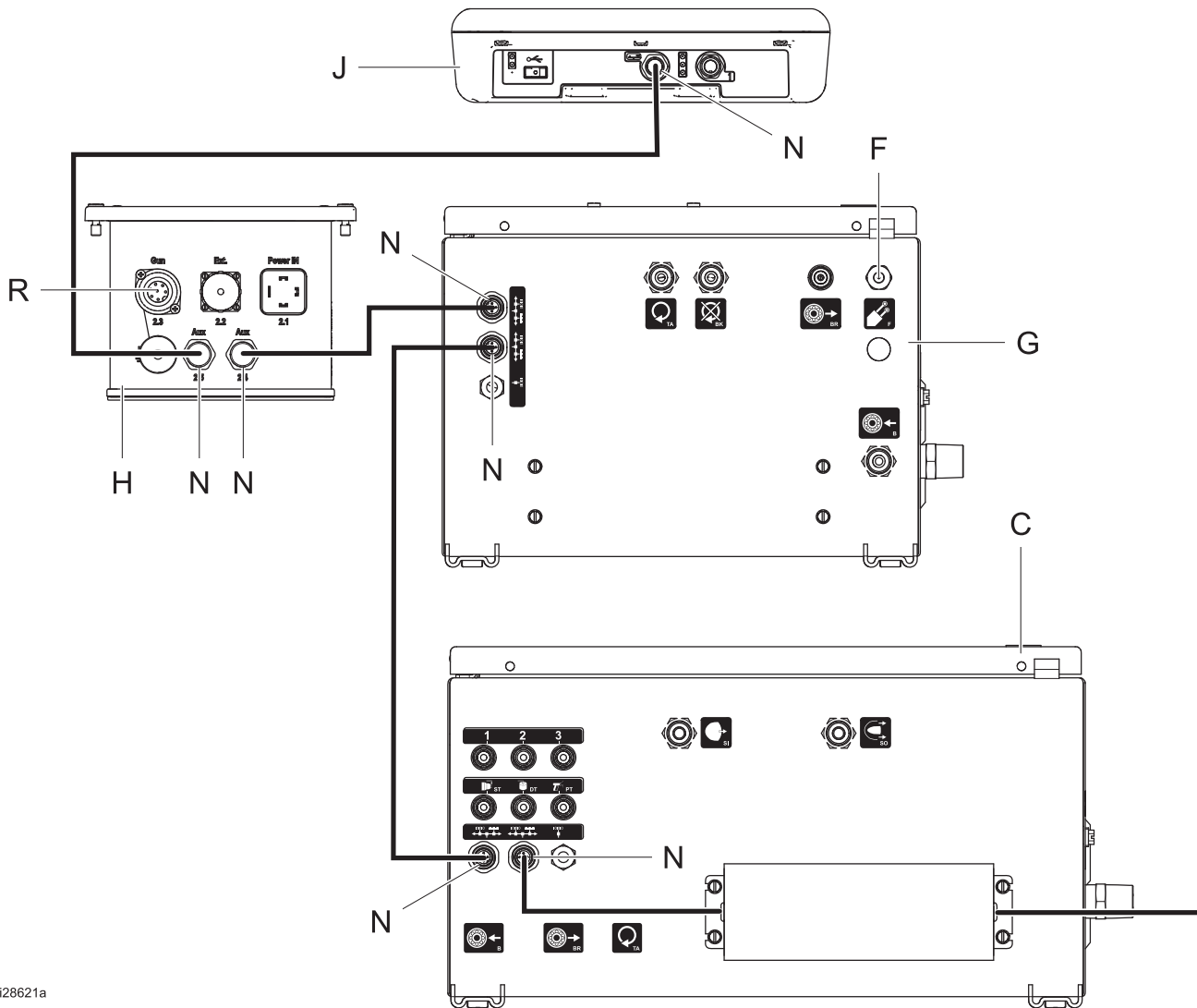

ti28621a

**FIG. 11 Power and Communication Cable Connections**

**KEY**

- C Air Controller
- F Fiber Optic Port
- G Speed Controller
- H Electrostatic Controller
- J System Logic Controller
- N CAN Ports
- R Applicator Power Supply Connector Port

## Step 7. Prepare the Spray Area

### Mount Warning Signs

Mount warning signs in the spray area where they can easily be seen and read by all operators. An English warning sign is provided with the applicator.

### Ventilate the Spray Booth



Do not operate the applicator unless ventilation fans are operating. Provide fresh air ventilation to avoid the buildup of flammable or toxic vapors when spraying, flushing, or cleaning the applicator. Interlock the electrostatic controller and fluid supply to prevent operation unless ventilating air flow is above the minimum required value.

Electrically interlock the electrostatic controller with the ventilators so that the electrostatics turn off any time that the ventilation air flow falls below minimum values. Check and follow all national, state, and local codes regarding air exhaust velocity requirements. Verify the operation of the interlock at least once per year.

**NOTE:** High-velocity air exhaust will decrease the operating efficiency of the electrostatic system. The minimum allowable air exhaust velocity is 60 ft/minute (19 linear meters/minute).

## Step 8. Create Required System Interlocks



To help prevent fire, explosion, or electric shock, check and follow all national, state, and local codes regarding properly interlocking your spray system.

### NOTICE

To avoid damage to the bearing it is recommended that the bearing air remain on at all times.

### System Interlocks

The following system interlocks are needed to prevent fire, explosion, electric shock, or equipment damage.

- 1. Turbine air and bearing air:** Interlock so the turbine air will flow only if the air pressure on the bearing air return line is 70 psi (483 kPa) or higher. This interlock is included in the ProBell System Logic Controller. Bearing air must be on when the turbine is operating. Bearing air should be turned off only at the main air source and only after the cup has stopped spinning.
- 2. Paint trigger and turbine air:** Interlock so the applicator will spray only when the turbine is spinning. A minimum of 10K rpm is recommended. This interlock is included in the ProBell System Logic Controller.
- 3. Electrostatic controller and solvent supply:** Interlock so that electrostatics can be enabled only when solvent is not flowing in the solvent or paint lines. See Electrostatic Controller Manual 3A3657 for available interlocks.
- 4. Fluid supply and arc detection:** Interlock the fluid supply to shut off in the event of an arc detection fault.
- 5. Braking air and turbine air:** Interlock so the braking air flows only when the turbine air is off.
- 6. Electrostatic controller and all doors or openings in the spray area:** Interlock so the electrostatics turn off any time that entrance is gained. See Electrostatic Controller Manual 3A3657. Check interlock function weekly.

7. **Conveyor and paint trigger/electrostatics:** Interlock so the rotary applicator stops spraying and the electrostatics turn off if the conveyor stops moving.
8. **Electrostatic controller, fluid supply, and ventilation fans:** Interlock so the electrostatics and fluid supply turn off any time that the ventilation air flow falls below minimum values. See Electrostatic Controller Manual 3A3657.
9. **Electrostatic controller, fluid supply, and fire control system:** Interlock so the electrostatics and fluid supply turn off any time the automatic fire extinguishing system is activated. See Electrostatic Controller Manual 3A3657. Check interlock function every 6 months.
10. **Electrostatic controller and waterborne isolation system (for waterborne systems):** Interlock so the electrostatics turn off any time entrance to the isolation enclosure is gained. See Electrostatic Controller Manual 3A3657. Check interlock function weekly.

### System Status Output

A system status output is included in the ProBell Speed Controller. This output indicates when the ProBell system is in Off Mode, such as when an alarm occurs. The output can be used to interlock system functions with functions that are not controlled by the ProBell system. For example: If the paint trigger is outside the ProBell system, the paint trigger can be interlocked with the system status output to ensure that the paint flow is stopped in the event of a system alarm. See the ProBell Speed Controller Manual 3A3953 to connect the system status output.

### Optional Interlock Input

An optional interlock input for the ProBell System Logic Controller can be installed in the ProBell Speed Controller or the ProBell Air Controller. When 24 VDC is applied to this input, the system goes to Off Mode. Install Kit 24Z226. See Speed Controller Manual 3A3953 or Air Controller Manual 3A3954.

## Step 9. Ground the Equipment





The equipment must be grounded to reduce the risk of static sparking and electric shock. Electric or static sparking can cause fumes to ignite or explode. Improper grounding can cause electric shock. Grounding provides an escape wire for the electric current.

When operating the rotary applicator, any ungrounded objects in the spray location (people, containers, tools, etc.) can become electrically charged. Your system may include other equipment or objects which must be grounded. Your system must be connected to a true earth ground. Check ground connections daily. Check your local electrical code for detailed grounding instructions. The following are minimum grounding requirements for a basic electrostatic system.

- **Rotary Applicator:** Ground the applicator by connecting the power supply cable to a properly grounded Electrostatic Controller and connecting the ground wire to a true earth ground. The ground wire may be connected to the grounding lug on the electrostatic controller and then connected to a true earth ground.
- **Control Box Stand:** The stand is grounded by connection to the Electrostatic Controller bracket.
- **Air Controller and Speed Controller:** If not mounted on the Control Box Stand, use a ground wire and clamp to ground to a true earth ground.
- **Electrostatic Controller:** Use the ground wire and clamp provided to connect the Electrostatic Controller to a true earth ground.
- **Pump:** Ground the pump by connecting a ground wire and clamp as described in your separate pump instruction manual.
- **Voltage Isolation System (for waterborne systems):** Follow the grounding procedure in the manufacturer's instructions.
- **Fluid Hose (for waterborne systems only):** The hose is grounded through the conductive layer. Install the hose as instructed. See **Fluid Lines for Waterborne Materials, page 14** and **Waterborne Systems, page 21**.

- **Air compressors and hydraulic power supplies:** Ground the equipment according to the manufacturer's recommendations.
- **All air and fluid lines** must be properly grounded.
- **All electrical cables** must be properly grounded.
- **All persons entering the spray area** must wear shoes having conductive or dissipative soles, such as leather, or wear personal grounding straps. Do not wear shoes with non-conductive soles such as rubber or plastic. If gloves are necessary, wear the conductive gloves supplied with the gun. If non-Graco gloves are worn, cut off fingers or palm area of gloves to ensure your hand contacts the grounded gun handle. The measured insulation resistance of gloves and footwear must not exceed 100 megohm per EN ISO 20344, EN1149-5.
- **Object being sprayed:** Keep the workpiece hangers clean and grounded at all times. Resistance must not exceed 1 megohm.
- **The floor of the spray area:** must be electrically conductive and grounded. Do not cover the floor with cardboard or any non-conductive material which would interrupt grounding continuity.
- **Flammable liquids in the spray area:** must be kept in approved, grounded containers. Do not use plastic containers. Do not store more than the quantity needed for one shift.
- **All electrically conductive objects or devices in the spray area:** including fluid containers and wash cans, must be properly grounded.

## Check Electrical Grounding

				
<p>Megohm meter Part No. 241079 is not approved for use in a hazardous area. To reduce the risk of sparking, do not use the megohm meter to check electrical grounding unless:</p> <ul style="list-style-type: none"> <li>• The rotary applicator has been removed from the hazardous area;</li> <li>• Or all spraying devices in the hazardous area are turned off, ventilation fans in the hazardous area are operating, and there are no flammable vapors in the area (such as open solvent containers or fumes from spraying).</li> </ul> <p>Failure to follow this warning could cause fire, explosion, and electric shock and result in serious injury and property damage.</p>				

Check ground connections daily.

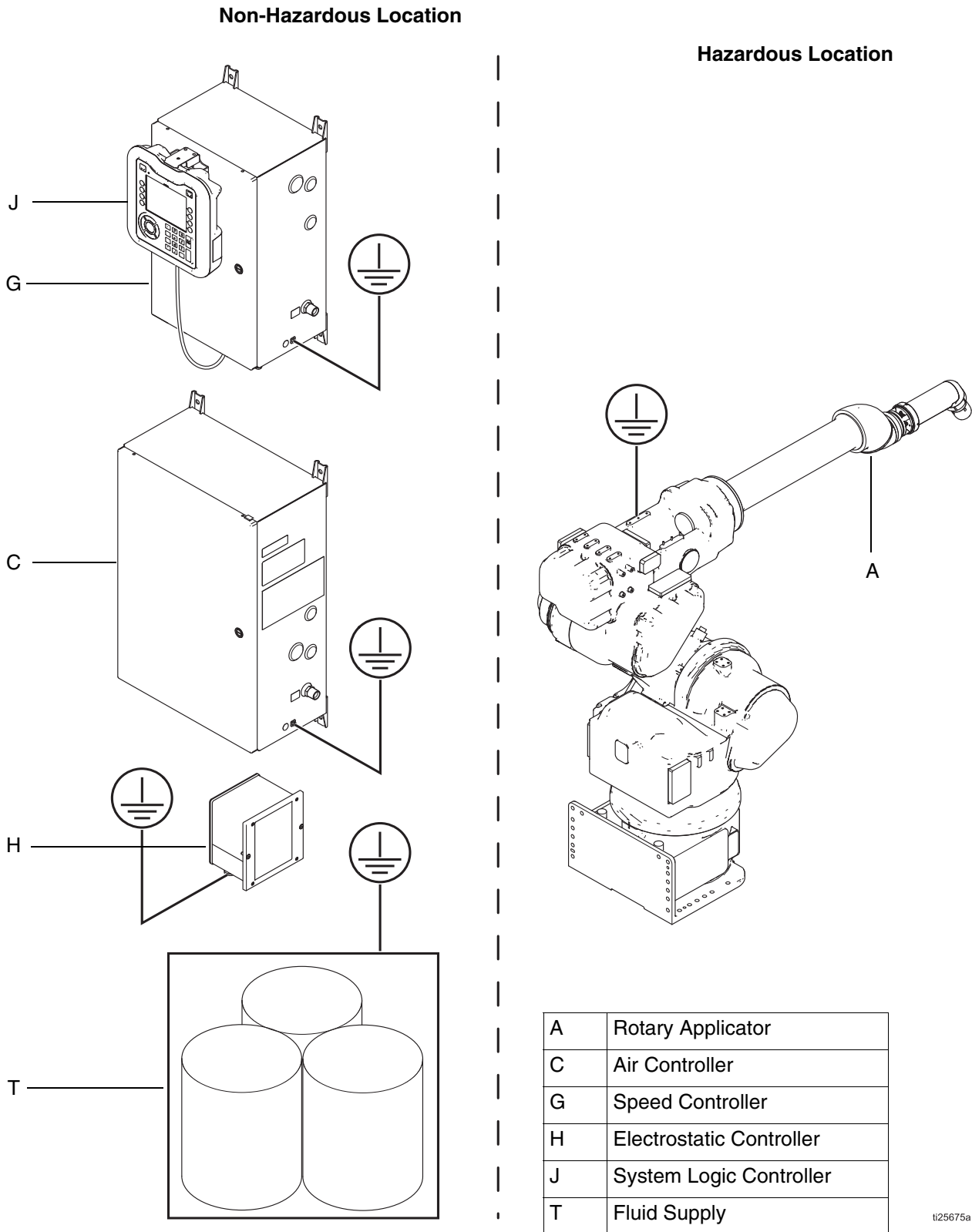

**FIG. 12. Grounding the System**

## System Logic Controller Setup

After installation, the following setup steps are required before Operation.

1. Use the Setup Screens on the System Logic Controller to set the following operating parameters. Detailed instructions are in the System Logic Controller Manual 3A3955.
  - Set the number of guns, type of guns, type of signal, idle timer and idle speed. See System Screen and Gun Screen 1.
  - Enable or disable and configure the Air Controller, See Gun Screen 2.
  - Set up the auxiliary solenoids on the Air Controller. See Gun Screen 3.
  - Enable or disable and configure Speed Controller gun screen. See Gun Screen 4.
  - Enable or disable and configure the Electrostatic Controller. See Gun Screen 5.
  - Configure spray parameters for all recipes using Presets 0 through 98. See Preset Screens.
2. Provide all information needed for the Gateway to enable communication via DeviceNet, Ethernet IP, Modbus TCP or PROFINET. See Gateway screens.
- Set language, date format, date, time, units, and other personal preferences. See Advanced Screens.
2. Use the Setup screens and the Configuration screens on the Electrostatic Controller to set up your system electrostatics. This setup is saved in the equipment memory, even when power is removed. All instructions are in the Electrostatic Controller Manual 3A3657.

**NOTE:** If you are using a PLC with only the Electrostatic Controller, see the Discrete I/O section in the Electrostatic Controller Manual 3A3657.

## Verification

After all installation steps are complete, and the System Logic Controller is configured, the system is ready for start up. Prior to running production, a knowledgeable person should check the functions shown in the table. This verification should be repeated on a regular basis.

Test	Requirement	Frequency
1. Proper Grounding	Verify proper grounding. See <b>Step 9. Ground the Equipment</b> , page 32.	Daily
2. Proper Clearance	Verify proper clearance is maintained between the cup and parts. See <b>Distance to Workpiece</b> , page 19.	Weekly
3. Arc Detection	Verify the function of the arc detection circuitry. See the arc detection information in the Electrostatic Controller Manual 3A3657.	Every 6 Months
4. Interlock with Ventilation	Verify proper operation of the interlock with the ventilation system. See <b>Step 8. Create Required System Interlocks</b> , page 31.	Every 6 Months
5. Voltage Discharge	Follow the <b>Voltage Discharge and Grounding Procedure</b> , page 40. Verify that access to the applicator (and the isolation system for waterborne) is prohibited until the discharge timer has elapsed and no residual voltage remains.	Each Cleaning
6. Waterborne System Interlock	Verify the proper operation of the interlock with the voltage isolation system. See <b>Step 8. Create Required System Interlocks</b> , page 31.	Weekly
7. Interlocks with Fluid	Verify the proper operation of the interlocks with the solvent supply and fluid supply. See <b>Step 8. Create Required System Interlocks</b> , page 31.	Weekly
8. Fire Suppression	Verify the proper operation of the interlock with the fire suppression system. See <b>Step 8. Create Required System Interlocks</b> , page 31.	Every 6 Months

# Operation

## Pre-Operation Checklist

Go through the Pre-Operation Checklist daily, before each use.

### All System Types

- All operators are properly trained to safely operate an automatic electrostatic rotary applicator system as instructed in this manual.
- All operators are trained in the **Pressure Relief Procedure** on page 40.
- The warning sign provided with the rotary applicator is mounted in the spray area where it can be easily seen and read by all operators.
- The system is thoroughly grounded and the operator and all persons entering the spray area are properly grounded. See **Step 9. Ground the Equipment** on page 32.
- The rotary applicator's mechanical and electrical components are in good condition.
- Ventilation fans are operating properly.
- Workpiece hangers are clean and grounded.
- All debris is removed from the spray area, including flammable fluids and rags.
- All flammable fluids in the spray booth are in approved, grounded containers.
- All conductive objects in the spray area are electrically grounded, and the floor of the spray area is electrically conductive and grounded.



- Applicator and hose connections show no signs of fluid leakage.
- All Setup is complete.
- Electrostatics are off and voltage is discharged according to **Voltage Discharge and Grounding Procedure**, page 40, before entering the spray area for any cleaning or maintenance work.

### Waterborne systems only

- Electrostatics are off and voltage is discharged according to the **Voltage Discharge and Grounding Procedure**, page 40 before any person enters the isolation enclosure, before cleaning, and before performing any maintenance or repair.
- The Graco waterborne fluid hoses (shielded or unshielded) are in good condition with no cuts or abrasions of the PTFE tube. Replace fluid hose if damaged.
- All fluids used meet one of the following flammability requirements:
  - Material does not sustain burning in accordance with the Standard Test Method for Sustained Burning of Liquid Mixtures, ASTM D4206.
  - Material is classified as non-ignitable or hard to ignite as defined by EN 50176.



## Check Fluid Resistivity

				
<p>Check the fluid resistivity in a non-hazardous area only. Resistance Meter 722886 and Probe 722860 are not approved for use in a hazardous area. Failure to follow this warning could cause fire, explosion, and electric shock and result in serious injury and property damage.</p>				

Graco Part No. 722886 Resistance Meter and 722860 Probe are available as accessories to check that the resistivity of the fluid being sprayed meets the requirements of an electrostatic air spray system.

Follow the instructions included with the meter and probe. Readings of 20 megohms-cm and above provide the best electrostatic results and are recommended.

Megohms-cm			
1-7	7-20	20-200	200-2000
Longer fluid hose may be needed*	Good	Best electrostatic results	Good electrostatic results

\* Included in kit #25A878.



## Check Fluid Viscosity



To check fluid viscosity you will need:

- a viscosity cup
  - a stopwatch
1. Completely submerge the viscosity cup in the fluid. Lift the cup out quickly. Start the stopwatch as soon as the cup is completely removed.
  2. Watch the stream of fluid coming from the bottom of the cup. As soon as there is a break in the stream, shut off the stopwatch.
  3. Record the fluid type, elapsed time, and size of the viscosity cup.
  4. Compare to the chart supplied by viscosity cup manufacturer to determine your fluid viscosity.
  5. If the viscosity is too high or too low, contact the material supplier. Adjust as necessary. See **Fluid**

Flow Rate Charts, page 88 to select the appropriate nozzle size.

## Spray Procedures

				
<p>To reduce the risk of electric shock and to avoid injury due to contact with the spinning cup, do not enter the spray area during rotary applicator operation.</p>				

				
<p>If any fluid leakage from the rotary applicator is detected, stop spraying immediately. Fluid leakage into the shroud could cause fire or explosion and result in serious injury and property damage.</p>				

### Flush Before First Use

The equipment was tested in fluid at the factory. To avoid contaminating your fluid, flush the equipment with a compatible solvent before using the equipment. See **Flushing**, page 39.

### Load Material

1. Put the system in Purge mode. In this mode:
  - a. Ensure that electrostatics cannot be enabled.
  - b. The bell should be rotating at least 10k rpm.
  - c. The Inner Shaping Air should be a minimum of 10 psi (0.7 bar) to help keep the applicator clean.
2. Supply paint to the paint line P.
3. Actuate the dump valve trigger (DT) until paint reaches the applicator. Actuate the paint valve trigger (PT) to load the paint to the front of the applicator.

**NOTE:** With this method, paint is returned through the dump line, rather than exiting out the front of the applicator. Paint remains in the dump line until the system is flushed. If your material has a low pot life, actuate the paint valve trigger (PT) to load paint.

4. Follow the **Cup Wash** procedure, page 39.

## Check Flow Rate

These instructions begin with material loaded.

1. Follow the **Cup Wash** procedure, page 39.
2. Put the system in Maintenance Mode. In this mode:
  - The electrostatics are off.
  - The shaping air is off.
  - The turbine air is off (not rotating).
  - The bearing air may remain on.
3. Remove cup and air cap. See **15 mm or 30 mm Cup**, page 54, or **50 mm Cup**, page 54.
4. Actuate the paint valve trigger (PT).
5. Measure the flow into a container. Use a stop watch to measure the time. Calculate the flow rate.
6. To increase the flow rate:
  - Increase the regulated fluid pressure of the material.
  - Increase the size of the fluid nozzle.
  - Reduce the viscosity of the material.
  - Use a larger diameter fluid hose up to the bell.

To decrease the flow rate:

  - Reduce the regulated fluid pressure of the material.
  - Reduce the size of the fluid nozzle.
7. Reinstall the cup and air cap. See **15 mm or 30 mm Cup**, page 54, or **50 mm Cup**, page 54.

## Adjust the Spray Pattern

1. Put the system in Spray mode.
2. Select Preset 0 so the spray parameters can be independently adjusted.
3. Adjust the atomization:
  - a. Set the inner shaping air (SI) and outer shaping air (SO) to at least 10 psi (0.7 bar) to keep the bell clean.
  - b. Set the speed to 25K rpm.
  - c. If your system does not have a speed controller, start with the turbine air (TA) set at 0 and increase very slowly. Make sure not to over speed the turbine. See **Turbine Inlet Air Pres-**

**sure Charts**, page 84, for the required pressure to achieve a given speed.

- d. Actuate the paint valve trigger (PT).
- e. Increase the speed (or increase the turbine air pressure slowly) for finer atomization.
- f. Decrease the speed (or decrease the turbine air pressure slowly) for coarser atomization.

**NOTE:** Speed can be changed with the applicator triggered or not triggered.

4. Adjust the pattern size:
  - a. Start with 10 psi (0.7 bar) on both the inner and outer shaping airs (SI and SO).
  - b. Increase the outer shaping air (SO) to reduce the pattern size or to improve applicator cleanliness (reduce wrap-back).
  - c. Increase the inner shaping air (SI) for additional pattern control.
5. Adjust the electrostatics:
  - a. Start with the maximum settings (100 kV, 150  $\mu$ A for Solventborne models; 60kV, 150  $\mu$ A for Waterborne models).
  - b. Decrease the voltage if test parts show evidence of thick edges or poorly covered recess areas (the Faraday effect).
  - c. Increase the voltage for improved wrap.
6. Follow the **Cup Wash** procedure, page 39.

## Spray a Part

1. Put the system in Spray mode. In this mode:
  - a. Inner and outer shaping airs (SI and SO) are on.
  - b. The turbine is spinning at the desired speed.
2. Position a part, or position the applicator, for material application.

3. Turn on the electrostatics. The Safe Position input and other required interlocks must be satisfied.
4. Actuate the paint valve trigger (PT) until desired coverage is achieved.

**NOTE:** Excessive paint may wrap back toward the applicator if the applicator is sprayed without a target present.

5. When finished, turn off the paint valve trigger first.
6. Then, turn off the electrostatics.
7. **Short Breaks:** Leave the shaping airs on and the turbine at speed.  
**Longer Breaks:** Follow the **Cup Wash** procedure, page 39. Put the system in Idle mode, which reduces the turbine speed and shaping airs to conserve energy.

### Cup Wash

Follow this cup wash procedure whenever you are done spraying parts, and as needed between parts depending on the material being sprayed and the rate of build-up. Some materials will require frequent cup washing.

1. Put the system in Purge mode. In this mode:
  - a. Ensure that electrostatics cannot be enabled.
  - b. The bell should be rotating at least 10k rpm.
  - c. The inner shaping air (SI) should be a minimum of 10 psi (0.7 bar) to help keep the applicator clean.
2. Activate the solvent valve trigger (ST).
3. Use air to purge the solvent.
  - a. Provide air to the solvent line S.
  - b. Actuate the solvent valve trigger (ST) to purge the cup wash solvent.

### Flushing



To avoid fire, explosion, and electric shock:

- Always turn off the electrostatics and discharge voltage when flushing, cleaning, or servicing equipment.
  - Always ground the equipment and waste container.
  - Flush the equipment only in a well-ventilated area.
  - Use only Group IIA materials. Non-ignitable fluids are preferred.
  - To avoid static sparking and injury from splashing, always flush at the lowest possible pressure.
- 
- Flush before changing fluids, before fluid can dry in the equipment, at the end of the day, before storing, and before repairing equipment.
  - Flush at the lowest pressure possible. Check connectors for leaks and tighten as necessary.
  - Flush with a fluid that is compatible with the fluid being dispensed and the equipment's wetted parts.

#### NOTICE

Use the lowest practical solvent pressure to perform flushing and cup wash procedures. Excessive solvent flow can cause fluid to flood the turbine and damage it.

1. Put the system in Purge mode. In this mode:
  - a. Ensure that electrostatics cannot be enabled.
  - b. The bell should be rotating at least 10k rpm.
  - c. The inner shaping air (SI) should be a minimum of 10 psi (0.7 bar) to help keep the applicator clean.
2. Provide solvent to the paint line P.

3. Actuate the dump valve trigger (DT) to flush the lines to the applicator. Close the dump valve when clear solvent exits the dump line. (Actuate the Paint trigger if the dump valve is not being used.)
4. Actuate the paint trigger (PT) to flush the fluid tube and nozzle.
5. Actuate the solvent valve trigger (ST) to wash the cup.

**NOTE:** If you need to **purge all solvent**, proceed with Step 6.

6. Use air to purge the solvent.
  - a. Provide air to the paint line P.
  - b. Actuate the dump valve trigger (DT) to purge the lines.
  - c. Actuate the paint valve trigger (PT) to purge the applicator.
  - d. Provide air to the solvent line S.
  - e. Actuate the solvent valve trigger (ST) to purge the cup wash solvent.

1. **Turn off the electrostatics.**  
Complete Step 1 of the **Voltage Discharge and Grounding Procedure**.
2. **Shut off the fluid and solvent supply.**
3. **Relieve the paint pressure.**  
Actuate the dump valve trigger (DT) to relieve pressure in the paint and dump lines. If your system does not have a dump valve, actuate the paint valve trigger (PT).
4. **Relieve Solvent Pressure.**  
Actuate the solvent valve trigger (ST) to relieve pressure in the solvent line.
5. **Turn off the turbine air and the shaping airs.**  
Put the system in Off mode.
6. **After the bell has stopped spinning, turn off the main air supply.**
7. **Disable the electrostatics and verify the voltage has been discharged.**  
Complete Steps 2-4 of the **Voltage Discharge and Grounding Procedure**.

## Pressure Relief Procedure



Follow the Pressure Relief Procedure whenever you see this symbol.



This equipment stays pressurized until pressure is manually relieved. To help prevent serious injury from pressurized fluid, such as splashing fluid and moving parts, follow the Pressure Relief Procedure when you stop spraying and before cleaning, checking, or servicing the equipment.

Follow these basic steps in the order shown to relieve the system pressure. The exact procedure to accomplish each step may vary based on your system design. Be certain that all steps are completed.



**NOTE:** Turn off the main air supply (bearing air) only after the cup has stopped spinning.

## Voltage Discharge and Grounding Procedure



The system is charged with high voltage until the voltage is discharged. Contact with the charged components of the applicator will cause an electric shock. For Waterborne systems, contact with the charge fluid supply system also will cause an electric shock. To avoid an electric shock, follow this procedure:



- before entering the spray area
- whenever you are instructed to discharge the voltage
- before cleaning or servicing the system equipment
- or before opening the isolation enclosure for the isolated fluid supply.

				
---	---	--	--	--

To avoid fire or explosion during the test, all spraying devices in the hazardous area must be turned off and ventilation fans in the hazardous area must be operating. Conduct the test only when no flammable vapors are present in the area (such as open solvent containers or fumes from spraying).

**NOTE:** An accessory grounding rod, part No. 210084, is available to discharge any voltage remaining on a system component.

1. Turn off the electrostatics by pressing  on the Electrostatic Controller, by using an Electrostatic Enable I/O signal, or by using CAN communication. Switching to Purge mode also will shut off the electrostatics. Wait the amount of time set for your system to discharge.

				
--	--	--	--	--

To avoid fire or explosion, or electric shock, always wait for the full discharge time to elapse. Once the electrostatics are turned off, the display no longer tracks or displays the actual voltage. Do not use the controller display to determine if the system is discharged.

**NOTE:** The procedure to set the discharge timer is found in the directions for Setup Screen 10 in the Electrostatic Controller manual (3A3657).

2. Put the system in Off mode.
3. Disable the electrostatics by powering off the Electrostatic Controller (set  on  off to off). **NOTE:** Electrostatics also can be disabled by removing an interlock, if preferred. An error will occur. When the procedure is finished, clear error to restart.
4. Verify that the system has discharged.
  - a. **For Solventborne Systems:** Touch the air cap cover (19) with a grounded rod to make sure the voltage has been discharged. If you see an arc, verify that the electrostatics are turned off. Increase the discharge time, or see **Electrical Troubleshooting**, page 50. The default discharge time is 5 seconds. Resolve the problem before proceeding.

- b. **For Waterborne Systems:** Discharge the voltage at the voltage isolation system by following the procedure specified in the voltage isolation system instruction manual. Touch the pump, supply pail, and applicator air cap cover with a grounded rod to make sure the voltage has been discharged. If you see an arc, verify that the electrostatics are turned off. Increase the discharge time. See **Electrical Troubleshooting**, page 50, or the voltage isolation system manual for other possible problems. The default discharge time is 60 seconds. Resolve the problem before proceeding.

5. Test voltage discharge weekly.

## Shutdown

1. Flush if needed. See **Flushing**, page 39.
2. Follow the **Pressure Relief Procedure**, page 40, which includes **Voltage Discharge and Grounding**.
3. Clean the cup and exterior of the applicator. See **Clean the Air Cap and Cup**, page 46. See also, **Clean the Outside of the Rotary Applicator**, page 47.

# Maintenance



Installing and servicing this equipment requires access to parts which may cause an electric shock or other serious injury if the work is not performed properly. Do not install or repair this equipment unless you are trained and qualified.

Contact with the charged components of the rotary applicator will cause an electric shock. Contact with a rotating cup also may cause injury. Do not touch the bell or come within 3 ft. (0.9 m) of the front of the applicator during operation.

To reduce the risk of an injury, follow the **Pressure Relief Procedure**, page 40, which includes **Voltage Discharge and Grounding**, before checking or servicing any part of the system, and whenever you are instructed to relieve the pressure.

## Daily Care and Cleaning Checklist



Check the following list daily upon completion of equipment usage.

- Flush the applicator.
- Check the fluid and air line filters.
- Clean the cup and the outside of the applicator. See pages 46-47.
- Inspect the rotary atomizer and the cup for nicks, scratches, or excessive wear.
- Check for fluid leakage from the applicator and fluid hoses.

## Check for Fluid Leakage



If any fluid leakage from the applicator is detected, stop spraying immediately. Fluid leakage could cause fire or explosion, and result in serious injury and property damage.

**NOTE:** During operation, periodically remove the shroud to check for the presence of fluid. See FIG. 13 for location of potential leaks.

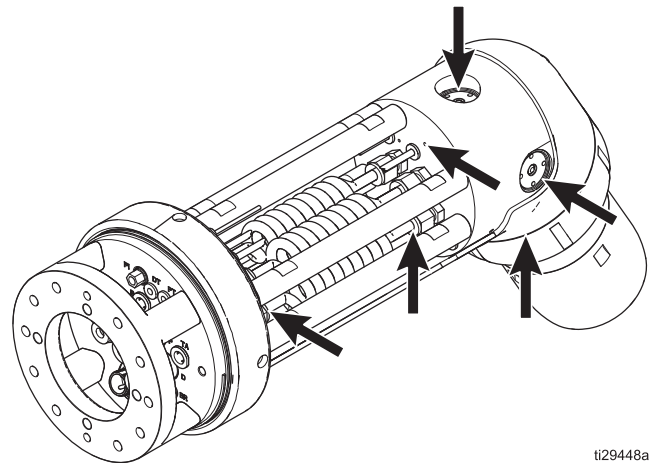

t129448a

**FIG. 13 Check for Fluid Leakage**

Fluid in these locations indicates leakage, which could be caused by the fluid tube connectors, manifold o-rings, or fluid valve leakage.

If fluid is seen in any of these locations:

1. Stop spraying immediately.
2. Follow the **Pressure Relief Procedure**, page 40, which includes **Voltage Discharge and Grounding**.
3. Follow the **Shutdown Procedure**, page 41.
4. Remove the applicator for repair.

## Electrical Tests



Megohm meter Part No. 241079 (AA-see FIG. 14) is not approved for use in a hazardous location. To reduce the risk of sparking, do not use the megohm meter to check electrical grounding unless:

- The applicator has been removed from the hazardous location;
- Or all spraying devices in the hazardous location are turned off, ventilation fans in the hazardous location are operating, and there are no flammable vapors in the area (such as open solvent containers or fumes from spraying).

Failure to follow this warning could cause fire, explosion, or electric shock, and result in serious injury and property damage.

Electrical components inside the applicator affect performance and safety. The following procedures test electrical continuity between applicator components.

Use megohm meter (AA) and an applied voltage of 500 V. Connect the leads as shown.

**NOTE:** Follow the **Flushing Procedure**, page 39, and dry the fluid passages prior to performing electrical tests.

### Test Full Applicator with Power Supply

See FIG. 14.

Measure the resistance between the air cap cover and each pin on the power supply adapter. Make sure the spring pins can move freely.

Pin	Acceptable Range
P1	120-160 megohms
P2	120-160 megohms
P3	120-160 megohms
P4	9.0-11.0 gigohms

- If resistance is within this range, testing is complete for the applicator. If electrical problems remain, make sure the spring pins are making contact with the mating connector (41) in the robot base.

- If resistance is outside this range, test the power supply and the front housing separately.

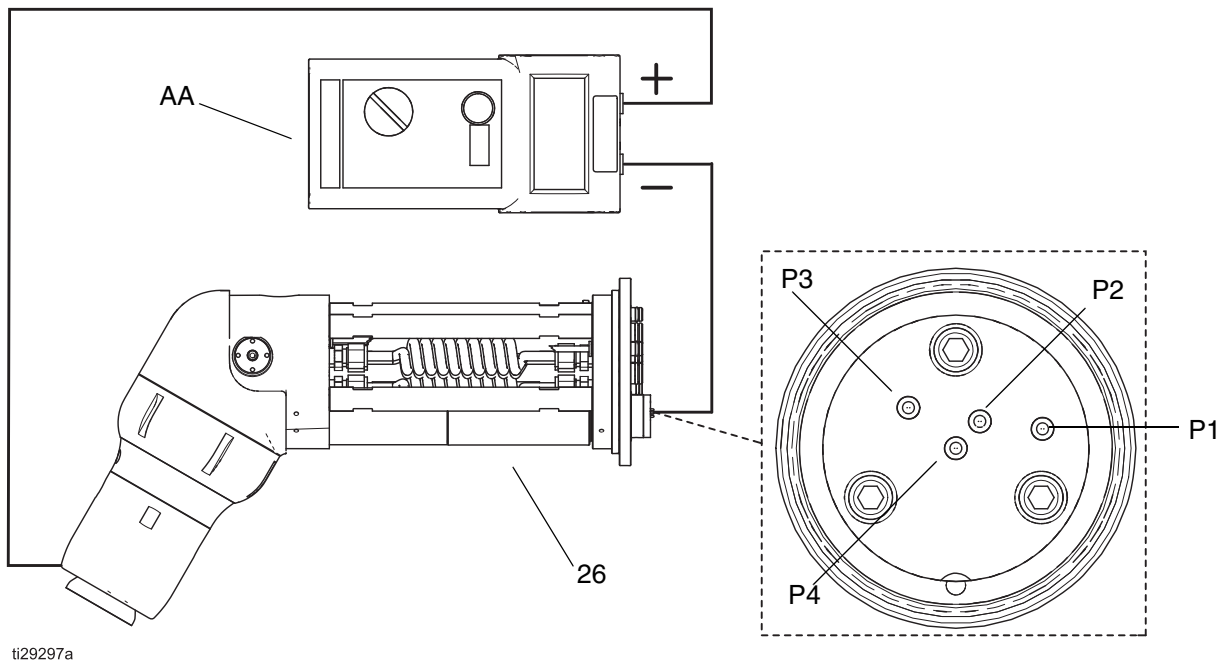

**FIG. 14 Full Applicator and Power Supply**



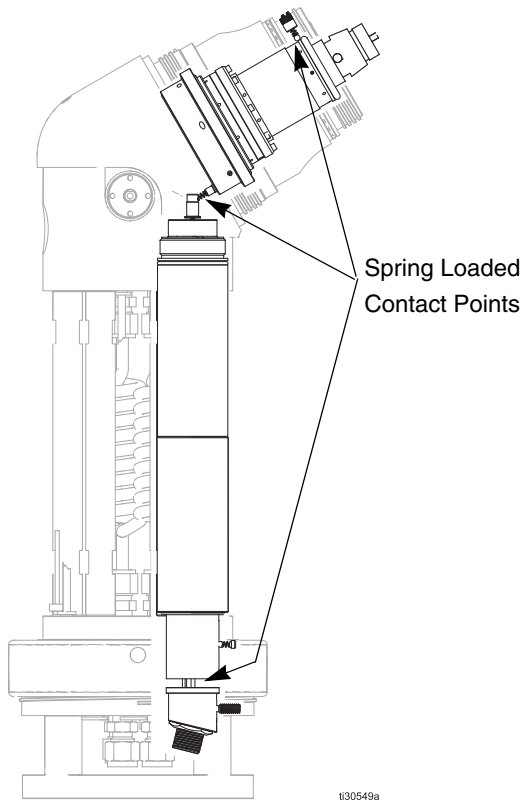

**FIG. 15 Hollow Wrist Electrical Path**

## Test Power Supply in Main Housing

1. Remove front housing and turbine assembly. See **Replace Front Housing and Turbine Assembly**, page 59 for removal instructions if needed.

2. Measure resistance between the main housing contact and the power supply adapter pins 1 and 4.

Pin	Acceptable Range
1, 2, 3	120 - 160 MΩ
4	9.0 - 11.0 GΩ

- If resistance is within range, proceed with testing the front housing.

- If resistance is out of range, proceed with step 3

3. Remove the spring pin adapter (62) by removing the 3 screws (63) and pulling the adapter out.

4. Repeat the measurement of step 2 going directly to the power supply pins.

- If resistance is within range, replace the spring pin adapter.

- If resistance is out of range, test the power supply resistance.

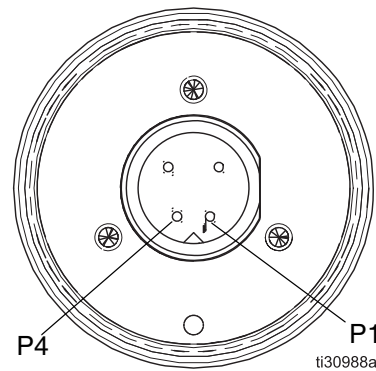



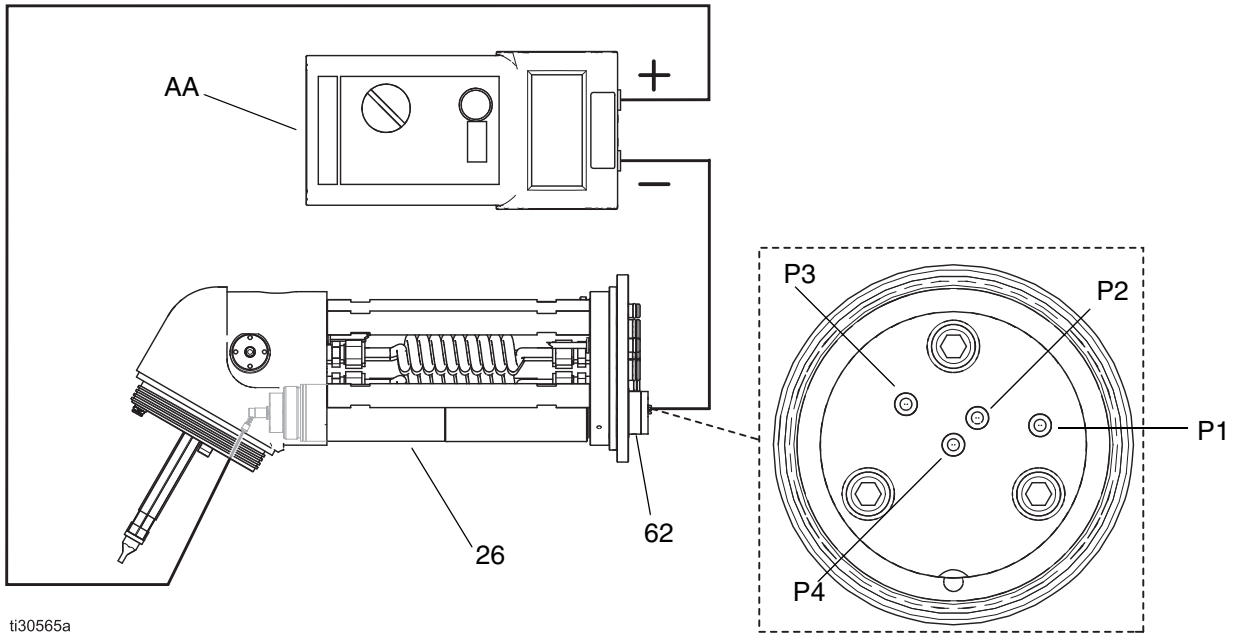

ti30565a

**FIG. 16 Full Applicator and Power Supply**

### Test Power Supply

See FIG. 17.

1. Remove the power supply (26). See **Replace the Power Supply**, page 66.
2. Measure resistance from each pin to the spring (28a).

Pin	Acceptable Range
P1, P2, P3	120-160 megohms
P4	9.0-11.0 gigohms

- If resistance is outside this range, replace the power supply.

- If resistance is within this range, reassemble the power supply in the main housing and retest. Make sure the power supply spring (28a) is making contact in the housing.

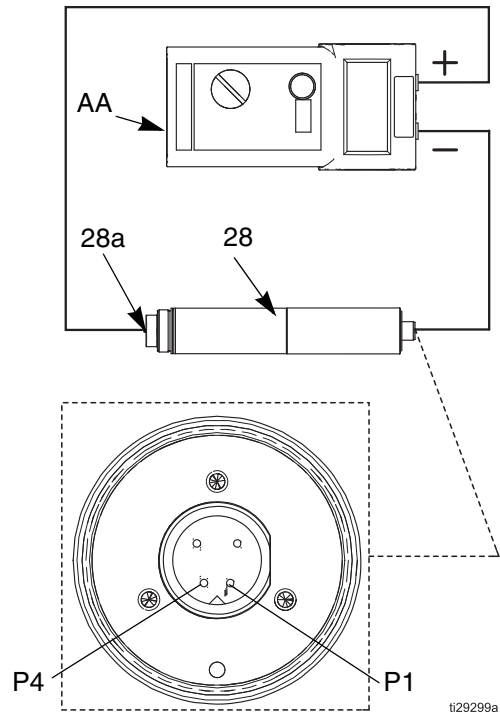

ti29299a

**FIG. 17 Power Supply Resistance**

## Test Front Housing

1. Remove front housing. See **Replace Front Housing and Turbine Assembly**, page 59, for removal instructions, if needed.
2. Measure resistance from the brass plug to the ball contact.
3. If resistance is <math><0.1</math> megohm, reassemble and retest the full applicator. Make sure spring loaded contacts are clean and making contact with the mating surface. Refer to FIG. 18.
4. If resistance is 0.1 megohm or greater, replace the front housing.

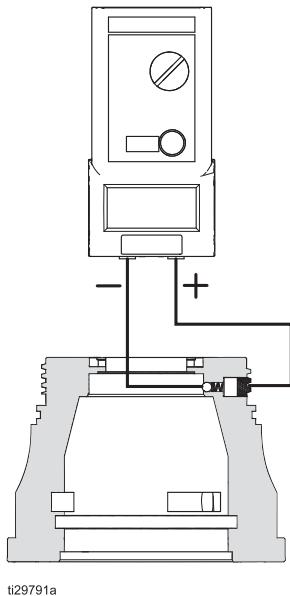

FIG. 18 Front Housing Resistance

2. Soak the cup in a compatible solvent until paint is loose. Remove **all** paint with a soft bristle brush dipped in solvent.
3. If necessary, clean the splash plate (20a) separately for easier access. Make sure the center holes of the splash plate are clean.
  - a. **15 mm cups:** Use tool (21). Turn counter clockwise to remove the splash plate.
  - a. **30 mm and 50 mm cups:** Place the cup face down on a soft and non-abrasive surface. Press out the splash plate with the post end of the fluid valve tool (53).

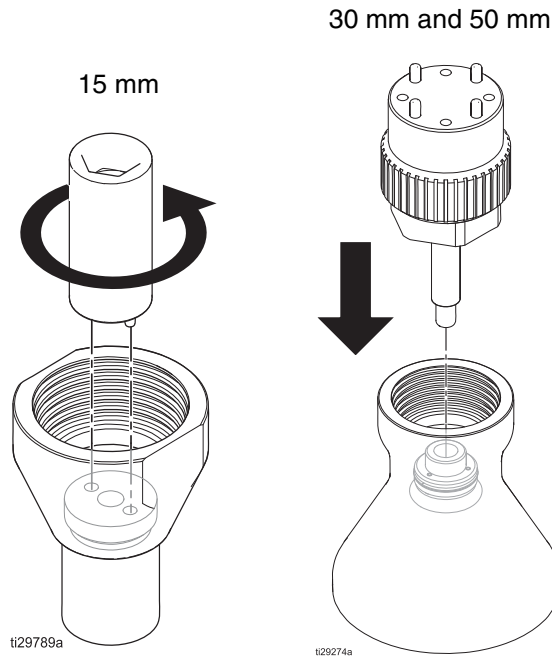

FIG. 19. Remove Splash Plate

## Clean the Air Cap and Cup



### Equipment Needed

- soft bristle brush
  - compatible solvent
1. Remove the cup. See **Replace Cup or Air Cap**, page 54.

### NOTICE

Use only tool 25C438 (Ref. 21, 15 mm), tool 25C200 (Ref. 53, 30 mm or 50 mm), or your thumb to remove the splash plate. Other tools could damage the surface finish, taper connection, or threads, making the cup inoperable.

4. Reinstall the splash plate (20a).
  - a. **15 mm cups:** Use tool (21) to turn the splash plate clockwise to 20-25 in-lbs (2.3-2.8 N•m).

- b. **30 mm and 50 mm cups:** Use your thumb to press the splash plate (20a) back in.

#### NOTICE

Do not use the fluid valve tool (53) to install the splash plate. It might slip and damage the cup.

5. If the press fit of the splash plate feels loose, service the split ring (20b). If the press fit is too tight, verify alignment. Remove and re-align if necessary.
6. Rinse the cup and dry it.
7. Clean the air cap with the soft bristle brush and solvent, or submerge the air cap in a suitable solvent and wipe it clean. Do not use metal tools.
8. To maximize pattern control, clean the shaping air holes and the air cap cover. Be sure they are not blocked. Soak the parts in solvent and use compressed air to clear any plugged holes.
9. Inspect the parts for damage or excessive wear. Replace if needed.
10. Reassemble. See **Replace Cup or Air Cap**, page 54.

## Clean the Fluid Nozzle

### Equipment Needed:

- soft bristle brush
- compatible solvent

**NOTE:** The nozzle is reverse threaded.

1. Follow all steps in **Repair Fluid Nozzle**, page 60.
2. Remove o-ring (8).
3. Soak the nozzle in a compatible solvent until paint is loose. Remove **all** paint with a soft bristle brush dipped in solvent.
4. Rinse the nozzle and dry it.

## Clean the Outside of the Rotary Applicator

#### NOTICE

- Clean all parts with a non-conductive, compatible solvent. Conductive solvents can cause the applicator to malfunction.
- Fluid in the air passages could cause the applicator to malfunction and could draw current and reduce the electrostatic effect. Whenever possible, point the applicator down when cleaning it. Do not use any cleaning method which could allow fluid into the air passages.

1. Follow the **Pressure Relief Procedure**, page 40, which includes **Voltage Discharge and Grounding**.
2. Make sure the bell has stopped spinning. Then, clean the outside surfaces with a damp solvent rag. **Do not** allow solvent to get into the bell passages.
3. Dry the exterior surfaces.

# Troubleshooting

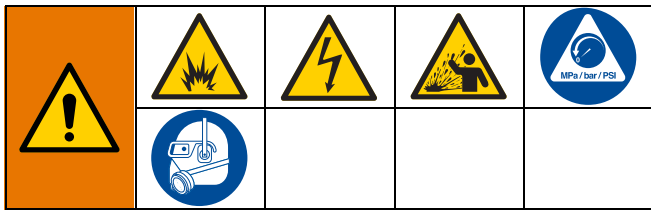

1. Follow **Prepare for Service**, page 53, before checking or repairing the applicator.
2. Check all possible problems and causes before disassembling the applicator.
3. See additional troubleshooting in the *System Logic Controller manual (3A3955)*.

## Spray Pattern Troubleshooting

Problem	Cause	Solution
Poor Spray Pattern	The cup (20) is damaged.	Replace.
	The air cap cover (19) is not tight.	Tighten.
	O-ring (16, 18c, or 18d) is missing.	Replace.
	Splash plate (20a) is dirty or damaged.	Clean or replace.
	Fluid flow rate is incorrect.	Check fluid pressure. Check nozzle size (9)
	Shaping air holes are clogged.	Disassemble and clean the air cap cover (19).
Fluttering or spitting spray.	The fluid supply is empty.	Refill supply.
	Air is in the fluid supply.	Check fluid source. Refill.
Poor wrap.	See <b>Electrical Troubleshooting</b> , page 50.	

## Applicator Operation Troubleshooting

Problem	Cause	Solution
Rotary applicator does not spray	Turbine (10) is not rotating.	Be sure the bearing air pressure is at least 70 psi and the turbine air pressure is sufficient. Inspect the turbine bearing for damage. If still not rotating freely, reference Spindle Inspection and Cleaning Service Instructions, 3A4794.
	Fluid supply is low.	Add fluid if necessary. Increase fluid pressure if needed.
	Paint valve (4) is not opening.	Verify at least 70 psig air pressure to the paint trigger line. Clean or replace paint valve.
	The fluid tube (7) or nozzle (9) is clogged.	Remove and clean, replace if necessary.

<b>Problem</b>	<b>Cause</b>	<b>Solution</b>
Rotary applicator will not stop spraying.	The paint valve (4) is stuck open.	Turn off the paint trigger air. If still spraying, turn off fluid supply and clean or replace paint valve.
	A valve seat (3) is damaged or worn.	Inspect, clean, or replace as needed.
Cannot reach desired fluid flow rate.	Fluid pressure is insufficient.	Increase.
	Fluid nozzle (9) orifice is too small.	Replace with the next larger size nozzle.
	Fluid tube (7) or nozzle is partially clogged.	Remove and clean, replace if necessary.
Fluid leakage from the front of the rotary applicator	Fluid valve (4) is loose.	Remove and clean. Tighten.
	Nozzle (9) is loose on fluid tube (7).	Remove and clean. Tighten.
	An o-ring (2, 8, or 83) is missing or damaged.	Inspect and clean. Replace as needed.
	The valve seat (3) is damaged or worn.	Inspect, clean, or replace as needed.
Fluid leakage from the dump valve.	Dump valve (4) is loose.	Remove and clean. Tighten.
	The valve seat (3) is damaged or worn.	Inspect, clean, or replace as needed.
Excessive vibration	The cup (20) is dirty.	Remove and clean any dried paint or other contaminant.
	Cup (20) is not fully secured on turbine shaft (10).	Inspect and clean the threads on the cup and shaft. Retorque.
	The cup (20) is damaged.	Remove, clean, and inspect. Replace as needed.
	Turbine (10) is rotating too fast (being supplied with too much air).	Decrease turbine air pressure.
Speed Sensor Error	The fiber-optic cable between the applicator and the speed controller is damaged or has surpassed the bend radius.	Repair or replace fiber-optic cable.
	The fiber-optic cable is not properly adjusted.	Adjust the amount of fiber extending past the nut.
	The fiber-optic connector is loose.	Reinstall and tighten.
	The magnetic speed pick-up sensor is not generating light.	Replace

## Electrical Troubleshooting

Problem	Cause	Solution
Voltage is still present after following the <b>Voltage Discharge and Grounding Procedure</b> , page 40.	Bleed resistor is damaged.	Measure power supply resistance.
	An air pocket in the fluid line has isolated the fluid near the applicator (waterborne models).	Determine cause and correct. Purge air from fluid line.
	The voltage isolation system failed (waterborne models).	Service the voltage isolation system.
Excessive paint is wrapping back.	Poor part grounding.	See <b>Step 9. Ground the Equipment</b> , page 32.
	The distance from applicator to part is incorrect.	Should be 9-14 in. (23-36 cm)
	The shaping air is insufficient.	Verify that shaping air is on. Increase setpoint if necessary.
Operator gets mild shock.	Operator is not grounded or is near an ungrounded object.	See <b>Step 9. Ground the Equipment</b> , page 32.
	Applicator is not grounded.	See <b>Step 9. Ground the Equipment</b> , page 32.
	Operator got too close to the applicator before the discharge time had elapsed.	Wait for the full discharge time to elapse. Check power supply resistance - Pin 4. Increase discharge timer setting, if needed.
Electrostatic Controller won't go over 60 kV.	The controller is designed for use with a waterborne system.	Purchase a controller designed for use with a solventborne system.
Paint wraps poorly on parts.	Electrostatics are missing or voltage is insufficient.	Turn ON at the electrostatic controller. Adjust and monitor as needed.
	Parts are insufficiently grounded.	Properly ground so the electrical resistance between the part and ground is 1 megohm or lower.
	Shaping air pressure is too high.	Decrease the shaping air (inner and outer) setpoints.
	Distance from applicator to part is incorrect.	Should be 9-14 in. (23-36 cm).
	Fluid resistivity is low.	See <b>Operation</b> , page 36.
The electrostatics are on, but there is no electrostatic effect from the applicator.	There is an error in the system (indicated by an error code on the electrostatic controller).	Refer to the Electrostatic Controller Manual (3A3657) to determine and address the cause.
	One or more parts have malfunctioned or need service.	Complete the <b>Electrical Tests</b> starting on page 43. Replace any out-of-specification parts. Retest.
	The power supply cable is damaged.	Test the power supply cable for continuity. See the Electrostatic Controller Manual (3A3657).
	<i>Waterborne Systems:</i> See <b>Waterborne System Voltage Loss Troubleshooting</b> , page 51, for possible causes and solutions.	

## Waterborne System Voltage Loss Troubleshooting

Normal spraying voltage for a system using the waterborne applicator is 40-55 kV. The system voltage is lower due to spraying current demands and voltage isolation system losses.

A loss of spraying voltage can be caused by a problem with the applicator, fluid hoses, or voltage isolation system, since all of the system components are electrically connected through the conductive, waterborne fluid.

Before troubleshooting or servicing the voltage isolation system itself, you need to determine which component in the system is most likely causing a problem. Possible causes include the following:

### Applicator

- Fluid leakage
- Dielectric breakdown at the fluid hose connections.
- Faulty power supply
- Excessive over spray on applicator surfaces
- Fluid in the air passages

### Waterborne Fluid Hose

- Dielectric failure of the hose (pin-hole leak in the PTFE layer)

### Voltage Isolation System

- Fluid leakage
- Dielectric breakdown of hoses, seals, or connections
- Isolators not functioning properly

### Visual Checks

First, check the system for any visible faults or errors to help isolate whether the applicator, fluid hose or voltage isolation system has failed.

1. Check that all of the air and fluid tubes and hoses are properly connected. Make sure waterborne

hose are secured at the proper height at the strain relief.

2. Check that the voltage isolation system valves and controls are properly set for operation.
3. Check that the interior of the isolated enclosure is clean.
4. Check that the voltage isolation system has sufficient air pressure.
5. Check that the electrostatics are turned on.
6. Check that the voltage isolation system's enclosure door is closed and that any safety interlocks are engaged and working properly.
7. Make sure the voltage isolation system is isolating the fluid voltage from ground.
8. To eliminate air gaps in the fluid column, spray enough fluid to purge the air out between the voltage isolation system and the applicator. An air gap in the fluid hose can break the electrical continuity between the applicator and the isolated fluid supply and cause a low voltage reading at the isolation system.
9. Check the outside of the applicator for accumulated overspray. Excessive overspray can create a conductive path back to a ground. Clean the exterior of the applicator.
10. Inspect the entire system for any visible fluid leakage and repair any fluid leaks that are found. Pay special attention to the following areas:
  - Applicator fluid valves.
  - Fluid hose: check for leakage or any bulges in the outer cover, which may indicate an internal leak.
  - Internal voltage isolation system components.

## Tests



If you still have no voltage, separate the applicator and fluid hoses from the voltage isolation system and check whether the applicator and hoses alone will hold voltage with the following test.

1. Flush the system with water and leave the lines filled with water.
2. Follow the **Pressure Relief Procedure**, page 40, which includes **Voltage Discharge and Grounding**.
3. Disconnect the fluid hoses from the voltage isolation system.

Avoid allowing any water to leak out of the fluid hose(s) as that could cause a significant air gap in the fluid column up to the cup, which can break the conductivity path and conceal a potential failure area.

4. Position the end of the hose(s) as far as possible away from any grounded surface. The end of the hose must be at least 1 ft. (0.3 m) from any ground. Make sure that no one is within 3 ft. (0.9 m) of the end of the hose.

**NOTE:** The conductive layer of the hose must remain grounded.

5. Using the controller, turn on the electrostatics to the applicator. Observe the voltage and current level on the controller.
  - If the voltage is 40 to 55 kV, the applicator and fluid hose are okay, and the problem is in the voltage isolation system.
  - If the spraying voltage is below 40 kV, the problem is in the applicator or fluid hoses.
6. Discharge the system voltage (see **Voltage Discharge and Grounding Procedure**, page 40).
7. Flush the fluid hoses and applicator with enough air to dry out the fluid passages.

8. Using the controller, turn on the electrostatics to the applicator. Observe the voltage and current level on the controller.
9. If the voltage is 40-55 kV, the applicator power supply is okay, and there is probably a dielectric breakdown somewhere in the fluid hoses or applicator. Continue with step 10.

If the voltage is below 40 kV, do the **Electrical Troubleshooting**, page 50, to check the applicator and power supply resistance. If those tests show the applicator and power supply are okay, continue with step 10.

10. A dielectric breakdown is most likely in one of the following three areas. Repair or replace the component that is failing.

a. Fluid hoses:

- Check each hose for leakage or any bulges in the outer cover, which may indicate a pin-hole leak through the PTFE layer. Disconnect the fluid hoses from the applicator, and look for signs of fluid contamination on the outside of the PTFE portion of the fluid tube.
- Inspect the end of each hose connected to the voltage isolation system. Look for cuts or nicks.
- Make sure each hose is properly stripped (see **Waterborne Systems, page 21**). Re-strip or replace the hose.

b. Fluid hose connection to the applicator:

- A breakdown at the fluid hose connection joint would be caused by fluid leaking past the fitting.

11. Clean and dry the fluid tubes, then reassemble the applicator.

12. Reconnect the fluid hoses.

Check the voltage before filling the applicator with fluid.



# Repair

## Prepare for Service



Installing and servicing this equipment requires access to parts which may cause an electric shock or other serious injury if the work is not performed properly. Do not install or repair this equipment unless you are trained and qualified.

Contact with the charged components of the rotary applicator will cause an electric shock. Contact with a rotating cup also may cause injury. Do not touch the bell or come within 3 ft. (0.9 m) of the front of the applicator during operation.

To reduce the risk of an injury, follow the **Pressure Relief Procedure**, page 40, before checking or servicing any part of the system, and whenever you are instructed to relieve the pressure.

### NOTES:

- Check all possible remedies in **Troubleshooting**, page 48, before disassembling the applicator.
- Lightly lubricate o-rings and seals with non-silicone grease. Order Part No. 111265 Lubricant. Do not over-lubricate.
- Only use genuine Graco parts.

## Prepare for Cup or Air Cap Service

1. Follow the **Pressure Relief Procedure**, page 40, which includes **Voltage Discharge and Grounding**.
2. Clean the applicator. See **Daily Care and Cleaning Checklist**, page 42.

## Prepare for Applicator Service

1. Flush the fluid lines.

2. Follow the **Pressure Relief Procedure**, page 40, which includes **Voltage Discharge and Grounding**.
3. Clean the applicator. See **Daily Care and Cleaning Checklist**, page 42.
4. Use the quick disconnect to remove the applicator from the robot base. Perform service or repair at a work bench.

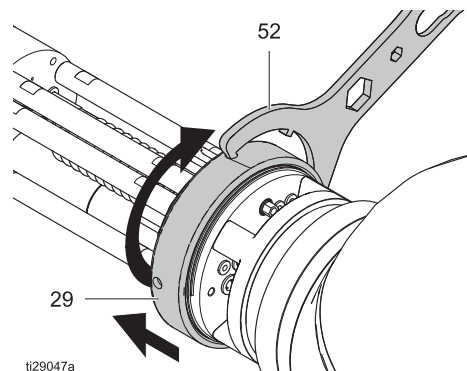

ti29047a

5. Remove the shroud (45) by pulling it straight back. The shroud is spring loaded for quick removal and replacement.
6. **Optional:** If needed for access, remove screws (46, 69) and remove the smaller rectangular section.

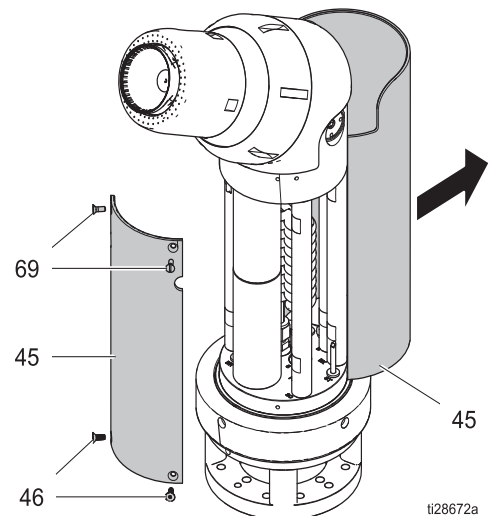

ti28672a

## Replace Cup or Air Cap

Use this section for a quick, on-line replacement of a damaged or worn cup. Cup replacement kits are available.

### 15 mm or 30 mm Cup

1. See **Prepare for Cup or Air Cap Service**, page 53.
2. Use the small end of the spanner wrench tool (52) to remove the air cap cover (19).

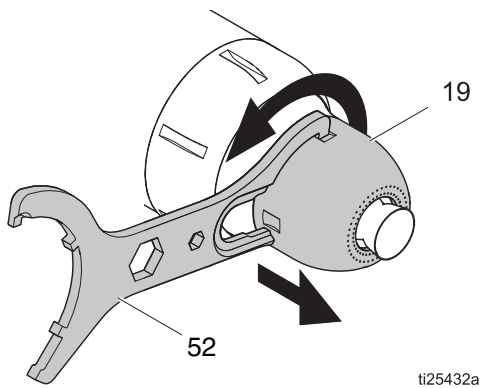

3. Remove the air cap (18).
4. Use the spanner wrench tool (52) to hold the turbine shaft, then screw off the cup (20).

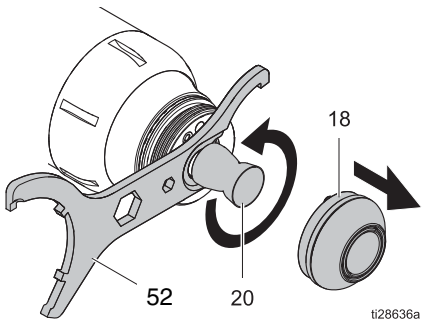

5. Hold the turbine shaft with the spanner wrench tool (52), and install the new cup (20) hand tight. Make

sure that the mating tapers are fully seated. Install the air cap (18).

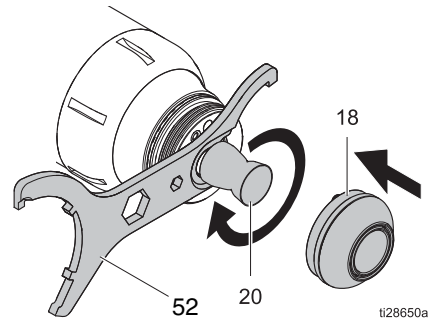

6. Use the small end of the spanner wrench tool (52) to install the air cap cover (19).

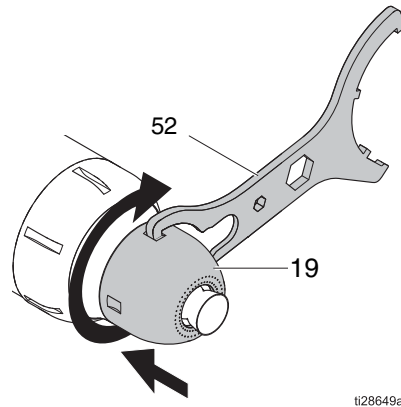

### 50 mm Cup

1. See **Prepare for Cup or Air Cap Service**, page 53.
2. Use the small end of the spanner wrench tool (52) to remove the air cap cover (19).

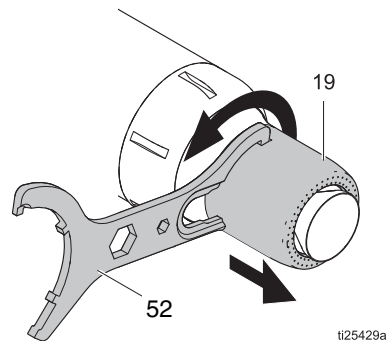

- To hold the shaft steady, insert the fluid valve tool (53) into the rectangular opening on the air cap (18). To lock rotation, slowly rotate the cup until the tool engages the hole in the shaft. Then, screw off the cup (20).

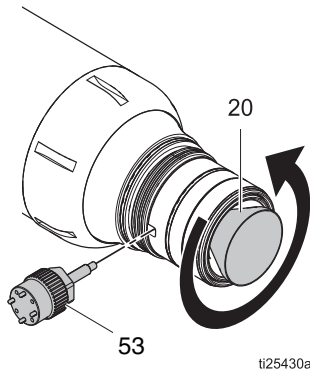

- Remove air cap (18). Inspect parts for damage and replace as needed. Reinstall the air cap (18) or install a new one.
- Start threading the new cup (20). Insert the fluid valve tool (53) into the rectangular opening on the air cap (18). Slowly rotate the cup until the tool engages the hole in the shaft. Then, tighten the cup (20) until the mating tapers are fully seated.

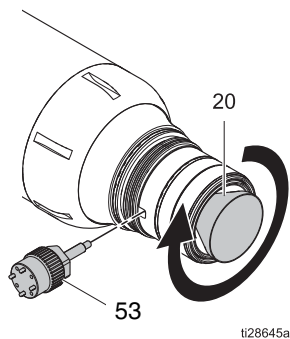

- Use the spanner wrench tool (52) to install the air cap cover (19).

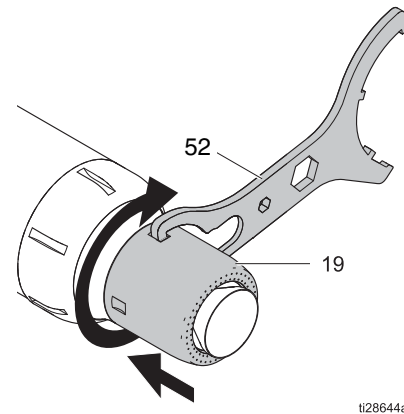

## Service the Cup and Air Cap

Use this section to remove your cup and air cap and fully disassemble each piece for cleaning or to replace any worn or damaged parts.

### NOTICE

Use only tool 25C438 (Ref. 21, 15 mm), tool 25C200 (Ref. 53, 30 mm or 50 mm), or your thumb to remove the splash plate. Other tools could damage the surface finish, taper connection, or threads, making the cup inoperable.

Do not use the fluid valve tool (53) to install the splash plate. It might slip and damage the cup.

### 15 mm Cup

- See **Prepare for Applicator Service**, page 53.
- Remove the air cap cover (19), cup (20) and air cap (18). See page 54.

- Use tool (21). Turn counter-clockwise to remove the splash plate (20a) from the cup (20). Clean parts and inspect for damage. Replace parts as needed.

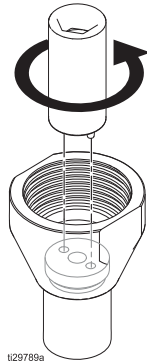

Clean all parts and inspect for damage. Replace parts as needed.

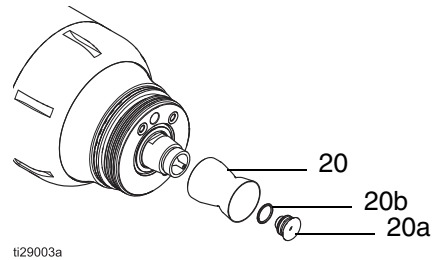
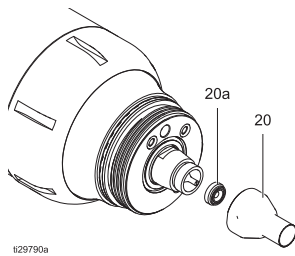
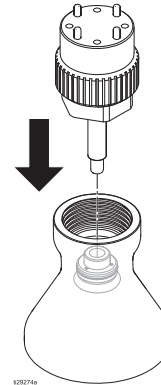

- Use tool (21) to reinstall the splash plate (20a). Turn the splash plate clockwise to 20-25 in-lbs (2.3-2.8 N•m).
- Grease the solvent stud o-ring (18c) and install the air cap (18), the cup (20), and the air cap cover (19) on the applicator. See page 54.

- Install the split ring (20b) on the splash plate (20a). Place the splash plate into the cup. Push in with your thumb until it is fully seated.
- Grease the solvent stud o-ring (18c) and install the air cap (18), the cup (20), and the air cap cover (19) on the applicator. See page 54.

### 30 mm Cup

- Prepare for Applicator Service**, page 53.
- Remove the air cap cover (19), cup (20) and air cap (18). See page 54.
- Use the fluid valve tool (53) to push the splash plate (20a) out of the cup. Remove the split ring (20b).

### 15 mm or 30 mm Air Cap

- Prepare for Applicator Service**, page 53.
- Remove the air cap cover (19), cup (20) and air cap (18). See page 54.
- Remove the solvent stud o-ring (83). Remove the solvent stud (82) only if you are experiencing a problem and need to replace it.
- Remove the outer air cap (18b). Also remove the o-ring (18c) from the inner air cap (18a). Clean all

parts and inspect for damage. Replace parts as needed.

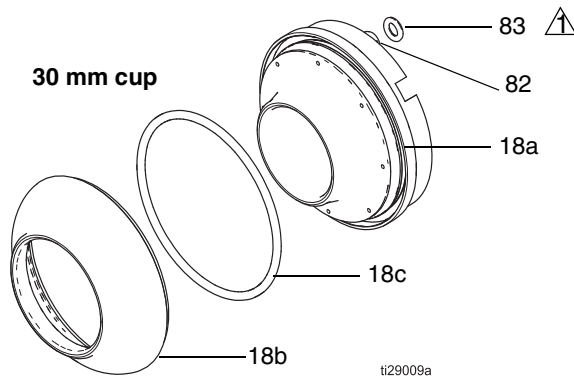
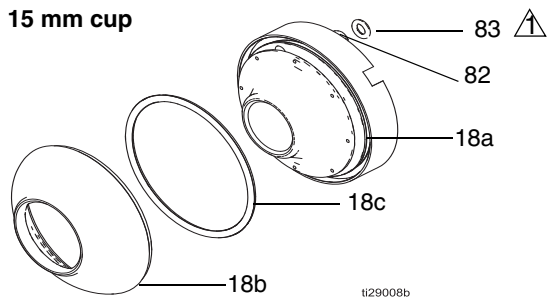

Apply lubricant.

5. Install the o-ring (83) on the solvent stud (82).
6. Install the o-ring (18c) on the inner air cap (18a), then fit the inner (18a) and outer (18b) air caps together.
7. Grease the solvent stud o-ring (83) and install the air cap (18), the cup (20), and the air cap cover (19) on the applicator. See page 54.

## 50 mm Cup

1. **Prepare for Applicator Service**, page 53.
2. Remove the air cap cover (19), cup (20), and air cap (18). See page 54.
3. Use the fluid valve tool (53) to push the splash plate (20a) out of the cup. Remove the split ring (20b). Clean all parts and inspect for damage. Replace parts as needed.

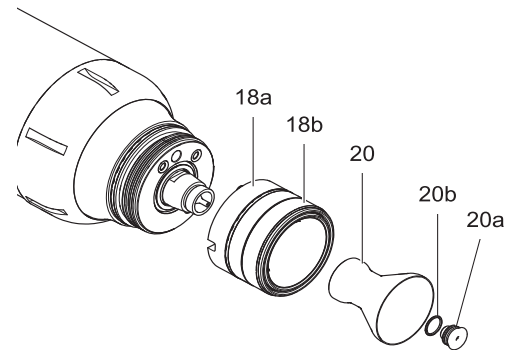
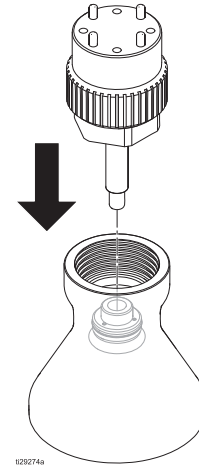

4. Install the split ring (20b) on the splash plate (20a). Place the splash plate into the cup. Push in with your finger until it is fully seated.
5. Grease the solvent stud and install the air cap (18), the cup (20), and the air cap cover (19) on the applicator. See page 54.

## 50 mm Air Cap

1. **Prepare for Applicator Service**, page 53.
2. Remove the air cap cover (19) and cup (20). See page 54.

- Slide off the air cap (18). Remove the outer air cap (18b). Remove the solvent stud o-ring (83). Remove the solvent stud (82) only if you are experiencing a problem and need to replace it. Clean all parts and inspect for damage. Replace parts as needed.

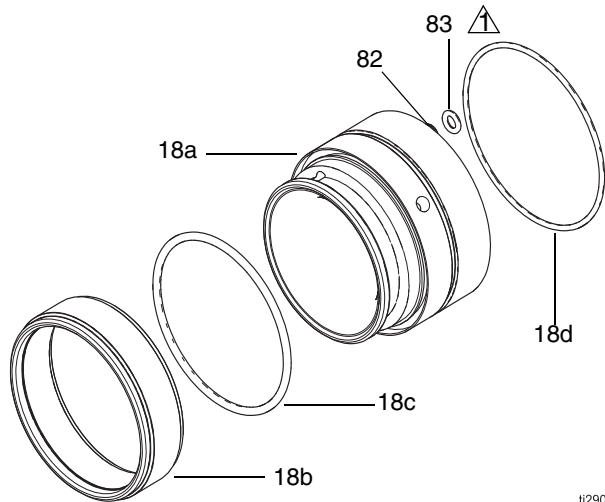

t129010a

 Apply lubricant.

- Install the o-ring (83) on the solvent stud (82).
- Install the o-rings (18c and 18d) on the inner air cap (18a), then fit the inner (18a) and outer (18b) air caps together.
- Grease the solvent stud o-ring (83) and install the air cap (18), the cup (20), and the air cap cover (19) on the applicator. See page 54.

## Replace Front Housing and Turbine Assembly

1. Prepare for Applicator Service, page 53.
2. Remove the air cap cover (19), cup (20) and air cap (18). See **15 mm or 30 mm Cup**, page 54, or **50 mm Cup**, page 54.
3. Use the larger end of the spanner wrench tool (52) to remove the retaining ring (15).

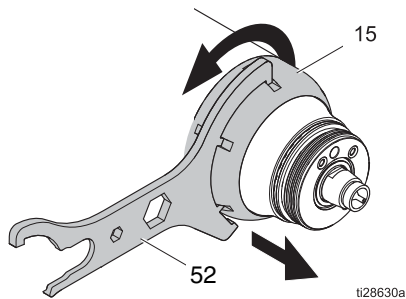

4. Remove the front housing (13), which includes the turbine assembly (10).
5. Place the threaded end of the turbine assembly (10) on a padded bench. Press down on the housing (13) to separate the housing and the turbine assembly.

### NOTICE

Be careful not to damage the threads when removing the turbine assembly from the front housing.

6. Remove the o-rings (11, 12, 14, 16, and 17) from the front housing.
7. Remove the o-rings (10a, 10b, and 10c) from the turbine assembly (10).

8. Clean all parts and inspect for damage. Replace parts as needed.

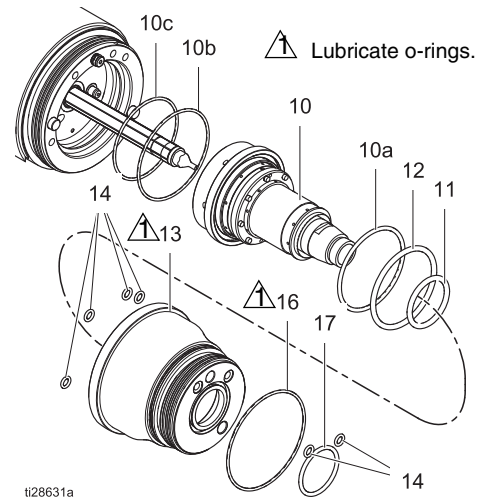

9. Install o-rings (11, 12, 14, and 17) on the front housing (13). Lubricate and install o-ring (16).
10. Install o-rings (10a, 10b, and 10c) on the turbine assembly (10).
11. Install the turbine assembly (10) into the front housing (13).
12. Grease the solvent stud o-ring. Use the solvent stud and the pins to align the front housing (13) with the main housing (1), then install the front housing.
13. Install the retaining ring (15). Use the larger end of the spanner wrench tool (52) to tighten it.

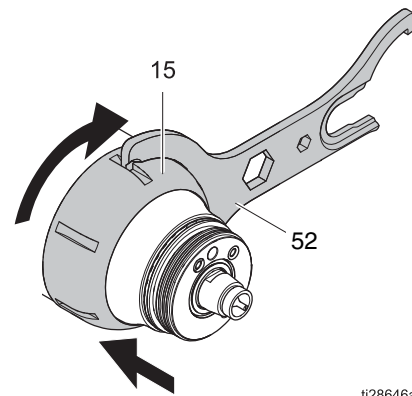

14. Grease the solvent stud o-ring and install the air cap (18), the cup (20), and the air cap cover (19) on the applicator. See **15 mm or 30 mm Cup**, page 54, or **50 mm Cup**, page 54.

## Repair or Replace the Solvent Stud

1. Prepare for Cup or Air Cap Service, page 53.
2. Remove the air cap cover (19), cup (20), air cap (18), retaining ring (15), turbine (10), and front housing (13).
3. Use a 1/4 in. hex wrench to remove the solvent stud (82) from the main housing (1) or the air cap (18). Remove the o-rings (83). One of the solvent stud o-rings probably will remain in the opening when the solvent stud is removed.
4. Install the o-rings (83) on the solvent stud (82). Lubricate the o-rings and tighten the solvent stud into the main housing (1) or the air cap. **Tip:** You may find it easier to lubricate the bottom o-ring and install it in the hole.
5. Install the front housing (13, including turbine assembly, 10) and retaining ring (15). See steps 12-13, page 59.
6. Grease the solvent stud o-ring (60) and install the air cap (18), the cup (20), and the air cap cover (19) on the applicator. See **15 mm or 30 mm Cup**, page 54, or **50 mm Cup**, page 54.

## Repair Fluid Nozzle

1. Prepare for Cup or Air Cap Service, page 53.
2. Flush the fluid lines.
3. Follow the **Pressure Relief Procedure**, page 40.
4. Remove the air cap cover (19), cup (20), air cap (18), retaining ring (15) and front housing (13).

5. Use the middle hexagon on the spanner wrench tool (52) to remove the fluid nozzle (9).

**NOTE:** The nozzle is reverse threaded.

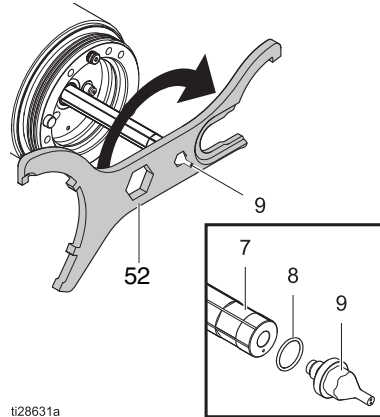

ti28631a

6. Inspect o-ring (8) and remove if damaged.
7. Install a new o-ring (8) on the nozzle (9).
8. Hold the fluid tube with a wrench. Use the middle hexagon on the spanner wrench to tighten the fluid nozzle. Torque to 58-62 in-lb (6.5-7.0 N•m).

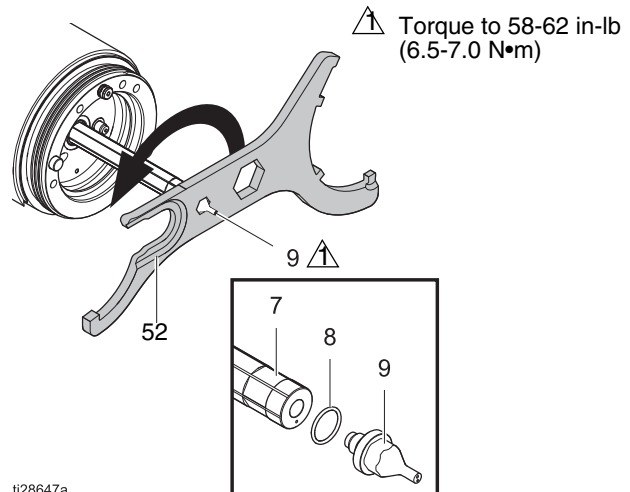

ti28647a

9. Install the front housing (13, including turbine assembly, 10) and retaining ring (15). See steps 12-13, page 59.
10. Grease the solvent stud o-ring and install the air cap (18), the cup (20), and the air cap cover (19) on the applicator. See **15 mm or 30 mm Cup**, page 54, or **50 mm Cup**, page 54.



## Repair or Replace the Fluid Tube

1. Prepare for Cup or Air Cap Service, page 53.
2. Flush the fluid lines.
3. Follow the **Pressure Relief Procedure**, page 41.
4. If not already disassembled, remove the air cap cover (19), cup (20), air cap (18), retaining ring (15) front housing (13), and fluid nozzle (9).
5. Use a 12 mm wrench to remove the fluid tube (7).

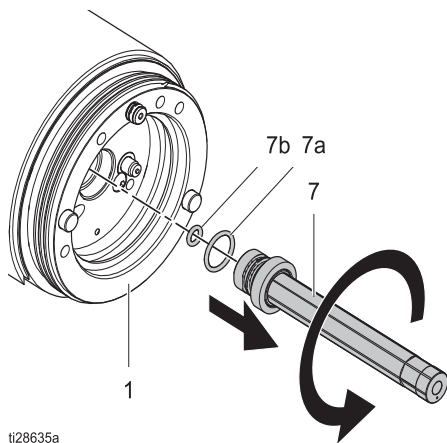

6. Inspect o-rings (7a, 7b) and remove if damaged.
7. Lightly grease and install new o-rings (7a, 7b) on the fluid tube.
8. Screw in a new fluid tube hand tight, then use a 12 mm wrench to tighten. Torque to 78-82 in-lb (8.8-9.3 N•m).

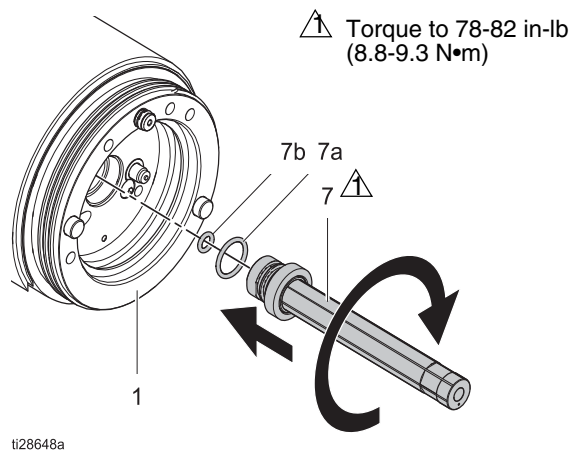

9. Install the front housing (13, including turbine assembly, 10) and retaining ring (15). See steps 12-13, page 59.
10. Grease the solvent stud and install the air cap (18), the cup (20), and the air cap cover (19) on the applicator. See **15 mm or 30 mm Cup**, page 54, or **50 mm Cup**, page 54.

## Replace Magnetic Pickup Sensor or Fiber Optic Extension Cable

1. Prepare for Applicator Service, page 53.
2. Remove the air cap cover (19), cup (20), air cap (18), retaining ring (15) and front housing (13).
3. Loosen the connector of the fiber optic extension cable (64) and remove it from the applicator base (30).
4. Remove the connector from the fiber optic extension cable so that it can pass through the main housing.
5. At the front of the main housing, use a 3/32 inch hex wrench to remove screw (6).
6. Pull the sensor (5) out of the main housing (1) so that the fitting on the fiber optic extension cable (64) is exposed. Loosen cable from sensor (5). If the extension cable needs to be replaced, nut (64A) and fitting 64B) must be removed from the applicator base end. Then the cable can be pulled through the main housing.

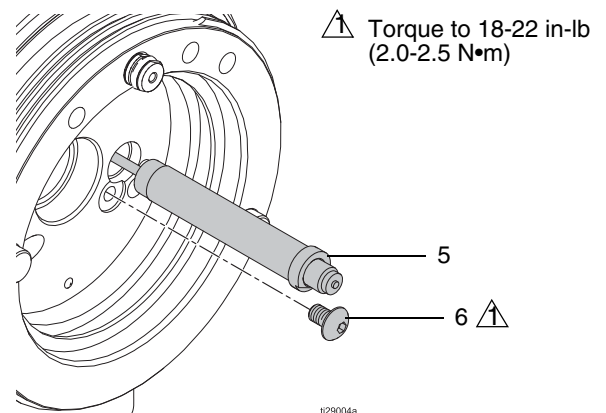

7. Install the new magnetic pickup sensor (5) and/or the new fiber optic extension cable (64). Install one end of the new fiber optic extension cable into the new magnetic pickup sensor. Remove the nut and fitting from the other end of the fiber optic extension cable. Pass the cable through the main housing and reinstall the fitting and nut. Verify the amount of fiber extending past the nut is 0.11 in (2.8 mm).

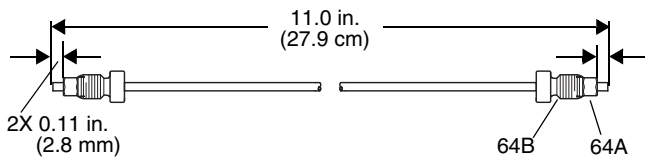

8. Install the new magnetic pickup sensor in the main housing. Line up the flat cut on the sensor with the hole for the screw.
9. Use a 3/32 inch hex wrench to tighten the screw (6). Torque to 18-22 in-lb (2.0-2.5 N•m).
10. At the applicator base, install the fiber optic extension cable (64) and tighten the connector.

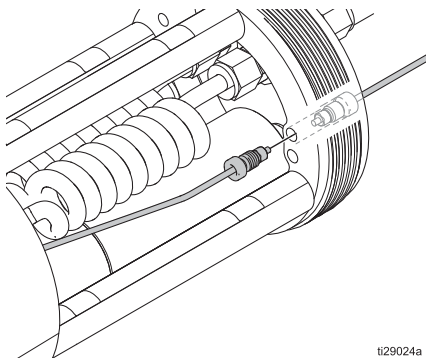

11. Install the front housing (13), including turbine assembly (10), and retaining ring (15). See steps 12-13, page 59.
12. Grease the solvent stud and install the air cap (18), the cup (20), and the air cap cover (19) on the applicator. See **15 mm or 30 mm Cup**, page 54, or **50 mm Cup**, page 54.

## Replace Fluid Valves and Seats

1. **Prepare for Applicator Service**, page 53.
2. Flush the fluid lines.

3. Follow the **Pressure Relief Procedure**, page 40, which includes **Voltage Discharge and Grounding**.
4. Remove the shroud (45).
5. Put the 4-prong end of the fluid valve tool (53) into the recessed holes on the fluid valve (4).

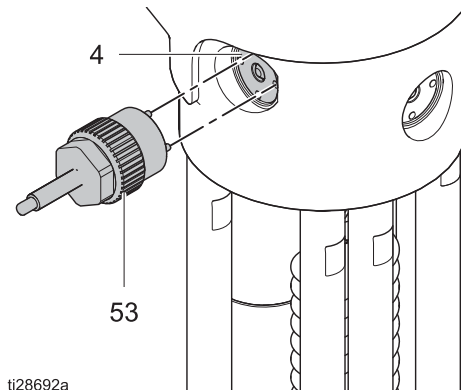

6. Use the large center hex of the spanner wrench tool (52) to remove the fluid valve (4). Remove the outer o-rings (4a and 4b) from the fluid valve. One o-ring (4b) may have remained in the housing. Inspect o-rings. Replace if damaged.
7. Use a 5/16 hex wrench to remove the seat (3). Remove the o-ring (2).
8. Inspect o-ring (2) and replace if damaged.

- ⚠ Torque to 9-11 in-lb (1.0-1.2 N•m).
- ⚠ Torque to 35-40 in-lb (4.0-4.5 N•m).
- ⚠ Lubricate the o-ring.

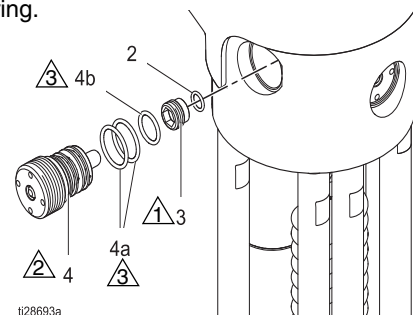

9. Lubricate the o-ring (2).
10. Install the new seat (3), with the o-ring side down.

11. Use a 5/16 hex wrench to tighten the seat. Torque seat to 9-11 in-lb (1.0-1.2 N•m).
  12. Install o-rings (4a and 4b) on the fluid valve.
  13. Lubricate the outside surfaces of the fluid valve. Avoid getting lubricant in the fluid path. Screw in the fluid valve, hand tight.
  14. Put the 4-prong end of the fluid valve tool (53) into the recessed holes on the fluid valve (4).
  15. Use the large center hex of the spanner wrench tool (52) to tighten the fluid valve (4). Torque to 35-40 in-lb (4.0-4.5 N•m).
  16. Use the quick disconnect ring (29) to reattach the applicator to the robot base (38). Tighten with the spanner wrench tool (52).
  17. Reinstall the shroud (45). Install and tighten the screws (46).
2. Use a 1/4 hex wrench to remove the five screws (32). Remove o-rings (27).

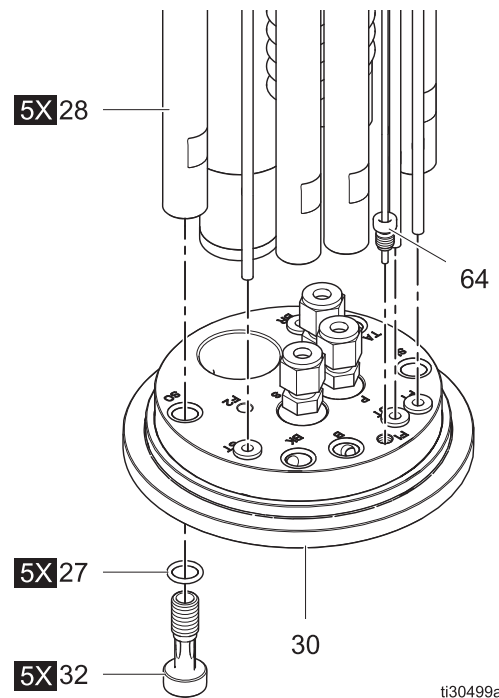

## Replace a Fluid or Air Fitting

### Applicator Base (30)

1. **Prepare for Applicator Service**, page 53.
3. Loosen the connector and disconnect the fiber optic extension cable (64).
4. Undo the four 5/32 air line connections.
5. Pull the applicator base (30) off of the tie rods (28).

- Remove a coiled fluid tube if connected to the damaged fitting.

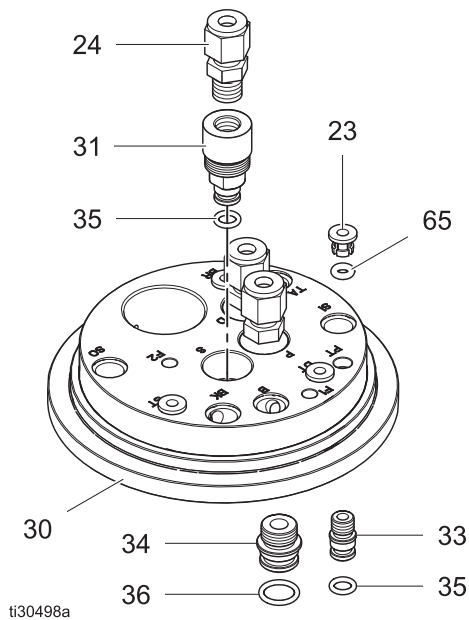

- Use a hex wrench to remove a fluid fitting or a flat screw driver to pry out an air fitting.
- Insert a new fitting into the applicator base (30). Add thread sealant and torque fluid fittings (24) to 20-25 in-lb (2.3-2.8 N•m).

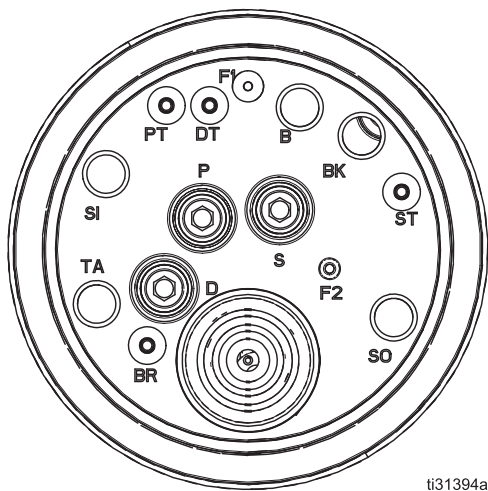

- Reconnect the coiled fluid tubes.
- Align and reattach the applicator base (30).
- Reconnect the four air lines and the fiber optic extension cable (64).

- Lubricate and install o-rings (27). Use a 1/4 hex wrench to tighten the tie rod screws (32). Torque to Torque to 30-35 in-lb (3.4-4.0 N•m).
- Use the quick disconnect ring (29) to reattach the applicator to the robot base (38). Tighten with the spanner wrench tool (52).
- Reinstall the shroud (45). Install and tighten the screws (46).

## Main Housing

- Prepare for **Prepare for Applicator Service**, page 53.
- Remove the Applicator Base. See steps 2-5 of **Applicator Base**. Disconnect coiled fluid tubes from applicator base.
- Remove the tie rods (28) or power supply (26) for access if needed.
- Remove the air line or coiled fluid tube that is connected to the damaged fitting.

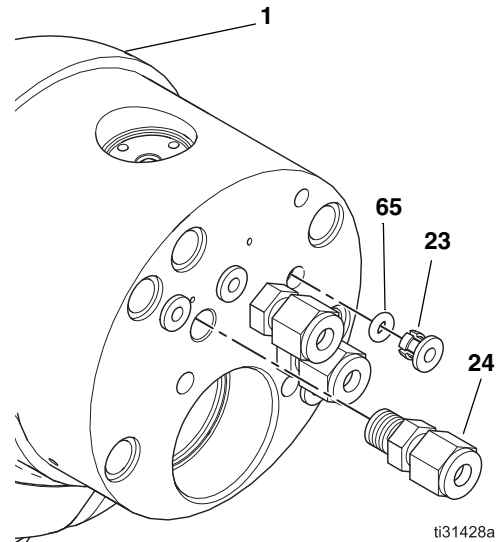

- Use a hex wrench to remove a fluid fitting or a flat screw driver to pry out a air fitting.
- Insert a new fitting into the main housing (1). Add thread sealant and torque fluid fittings (24) to 20-25 in-lb (2.3-2.8 N•m).
- Reconnect the air line or coiled fluid tube.
- If you removed the power supply (26), use dielectric grease to fill the two grooves on the end. Lubricate

the outer o-ring (26b). Tighten the power supply securely in place by hand. Be sure it is fully seated.

9. If you removed a tie rod (28), install o-ring (27) and reinstall the tie rod. Torque to 25-40 in-lb (2.8-4.5 N•m).
10. Reconnect the coiled fluid tubes to the applicator base.
11. Align and reattach the applicator base (30).
12. Reconnect the four 5/32 air lines and the fiber optic extension cable (64).
13. Lubricate and install o-rings (27). Use a 1/4 hex wrench to tighten the tie rod screws (32). Torque to 25-40 in-lb (2.8-4.5 N•m).
14. Use the quick disconnect ring (29) to reattach the applicator to the robot base (38). Tighten with the spanner wrench tool (52).
15. Reinstall the shroud (45). Install and tighten the screws (46).

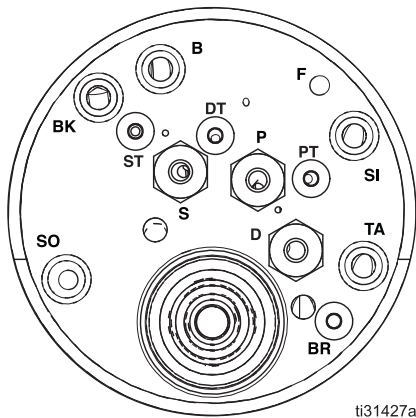

ti31427a

## Robot Base (38)

1. **Prepare for Applicator Service**, page 53.
2. Remove four screws (44) and disconnect the robot base (38) from the spacer (43).

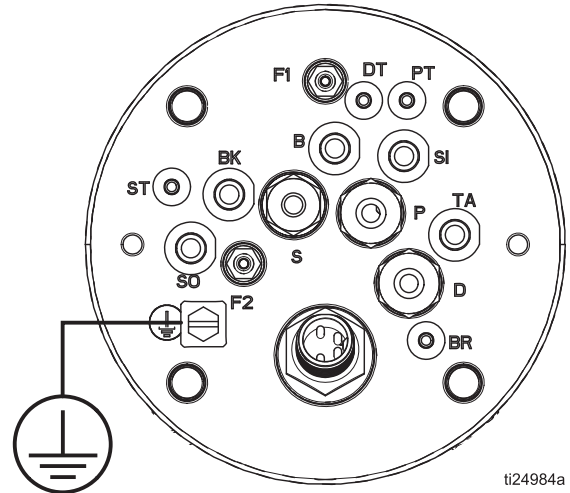

ti24984a

3. Remove the fluid or air line connected to the damaged fitting.

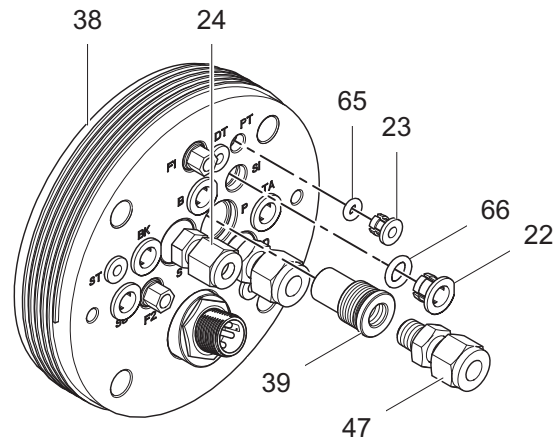

ti30500a



4. Use a hex wrench to remove a fluid fitting or a flat screw driver to pry out an air fitting.
5. Insert a new fitting into the robot base (38). Add thread sealant and torque fluid fittings (24, 47) to 20-25 in-lb (2.3-2.8 N•m).
6. Reconnect the fluid or air line.
7. Install and tighten four screws (44) to reattach the robot base (38) to the spacer (43).

8. Use the quick connect ring (29) to reattach the applicator to the robot base (38). Tighten with the spanner wrench tool (52).
9. Reinstall the shroud (45). Install and tighten the screws (46).

## Replace the Power Supply

1. **Prepare for Applicator Service**, page 53.
2. Use a 1/4 hex wrench to remove the five screws (32). Remove o-rings (27).
3. Loosen the connector and disconnect the fiber optic extension cable (64).
4. Undo the four 5/32 air line connections.
5. Pull the applicator base (30) off of the tie rods (28).
6. **TIP:** Remove one tie rod (28) for easier access to the power supply (26). Remove the o-ring (27).
7. Unscrew the power supply (26) by hand and remove from the housing.
8. If the spring pin adapter (62) needs to be replaced, remove 3 screws (63) and then take the adapter (62) off of the power supply.

9. Use the screws (63) to attach a new adapter (62) to the power supply.

-  Lubricate o-rings.
-  Apply dielectric grease to housing end.

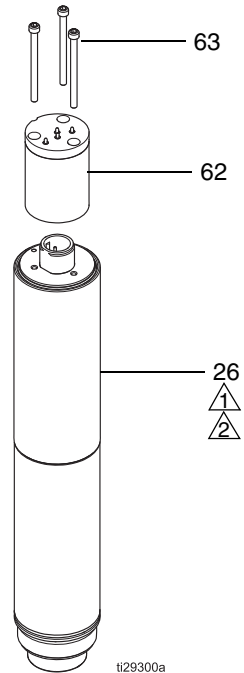

10. If the power supply connector (41) needs to be replaced, remove the setscrew (42) from the robot base, then the connector (41). Install a new connector and secure with the setscrew.

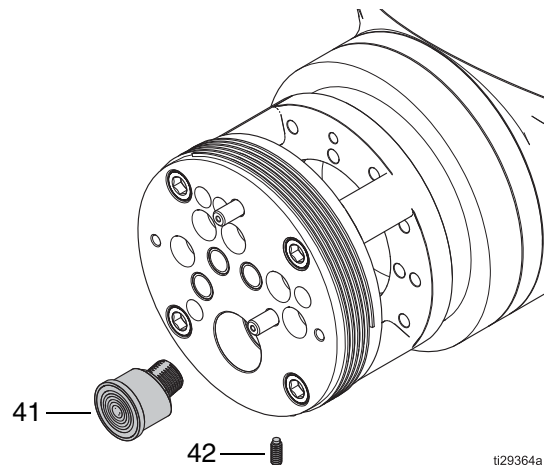

11. To install a new power supply (26), use dielectric grease to fill the two grooves on the end. Lubricate the outer o-ring (26b).
12. Tighten the power supply securely in place by hand. Be sure it is fully seated.

13. If you removed a tie rod (28), install o-ring (27) and reinstall the tie rod. Torque to 25-40 in-lb (2.8-4.5 N•m).
14. Align and reattach the applicator base (30).
15. Reconnect the four 5/32 in. air lines and the fiber optic extension cable (64).
16. Lubricate and install o-rings (27). Use a 1/4 hex wrench to tighten the tie rod screws (32). Torque to 25-40 in-lb (2.8-4.5 N•m).
17. Use the quick disconnect ring (29) to reattach the applicator to the robot base (38). Tighten with the spanner wrench tool (52).
18. Reinstall the shroud (45). Install and tighten the screws (46).



## Replace Coiled Fluid Tubes or Waterborne Fluid Tube Housing

1. **Prepare for Service**, page 53.
2. Use a 1/4 hex wrench to remove the five screws (32). Remove o-rings (27).
3. Loosen the connector and disconnect the fiber optic extension cable (64).
4. Undo the four 5/32 air line connections.
5. Pull the applicator base (30) off of the tie rods (28).
6. For solventborne systems, use a 9/16 wrench to loosen the nuts (24) on each side of the coiled fluid tube (25), then remove the tube. For waterborne systems, remove the fluid tube housing (85). Install the new o-ring (27) over the npt thread.

7. For solventborne systems, put a new coiled fluid tube (25) in place. Use the 9/16 wrench to tighten the nuts.
- For waterborne systems, install the new hose housing tube (85). Apply thread sealant. Tighten the tube until the o-ring is lightly compressed against the housing.
8. Align and reattach the applicator base (30).
9. Reconnect the four 5/32 in. air lines and the fiber optic extension cable (64)
10. Lubricate and install o-rings (27). Use a 1/4 hex wrench to tighten the tie rod screws (32). Torque to 25-40 in-lb (2.8-4.5 N•m).
11. Use the quick connect ring (29) to reattach the applicator to the robot base (38). Tighten with the spanner wrench tool (52).
12. Reinstall the shroud (45). Install and tighten the screws (46).

### Solventborne Systems

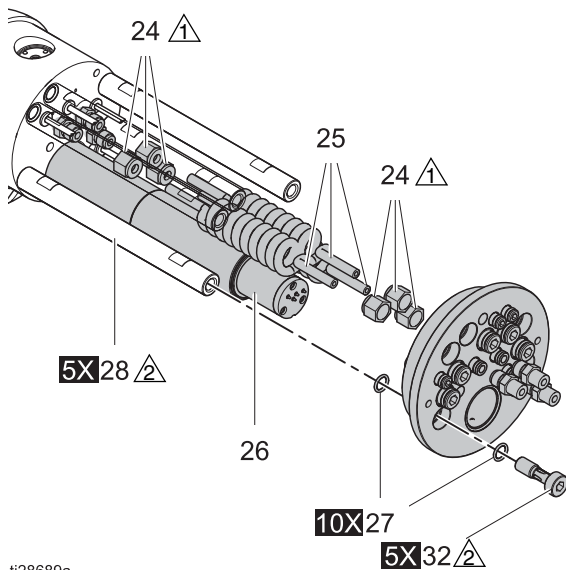

Torque to 20-25 in-lb (2.3-2.8 N•m).

Torque to 35-40 in-lb (4.0-4.5 N•m).

### Waterborne Systems

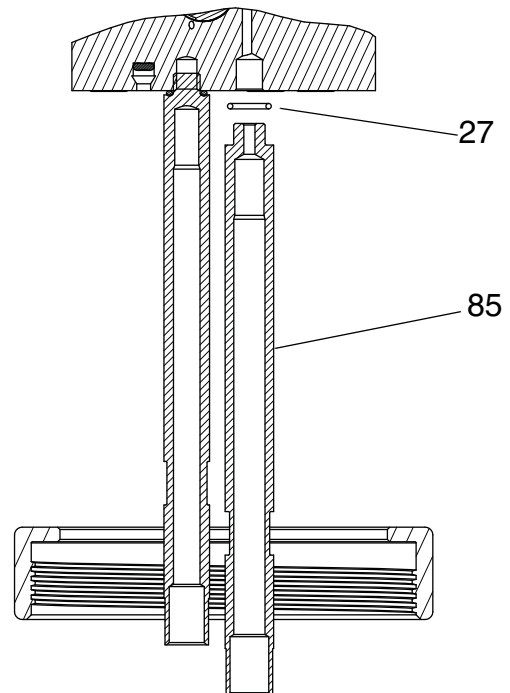



# Parts

## Solventborne Models (R\_A2\_0)

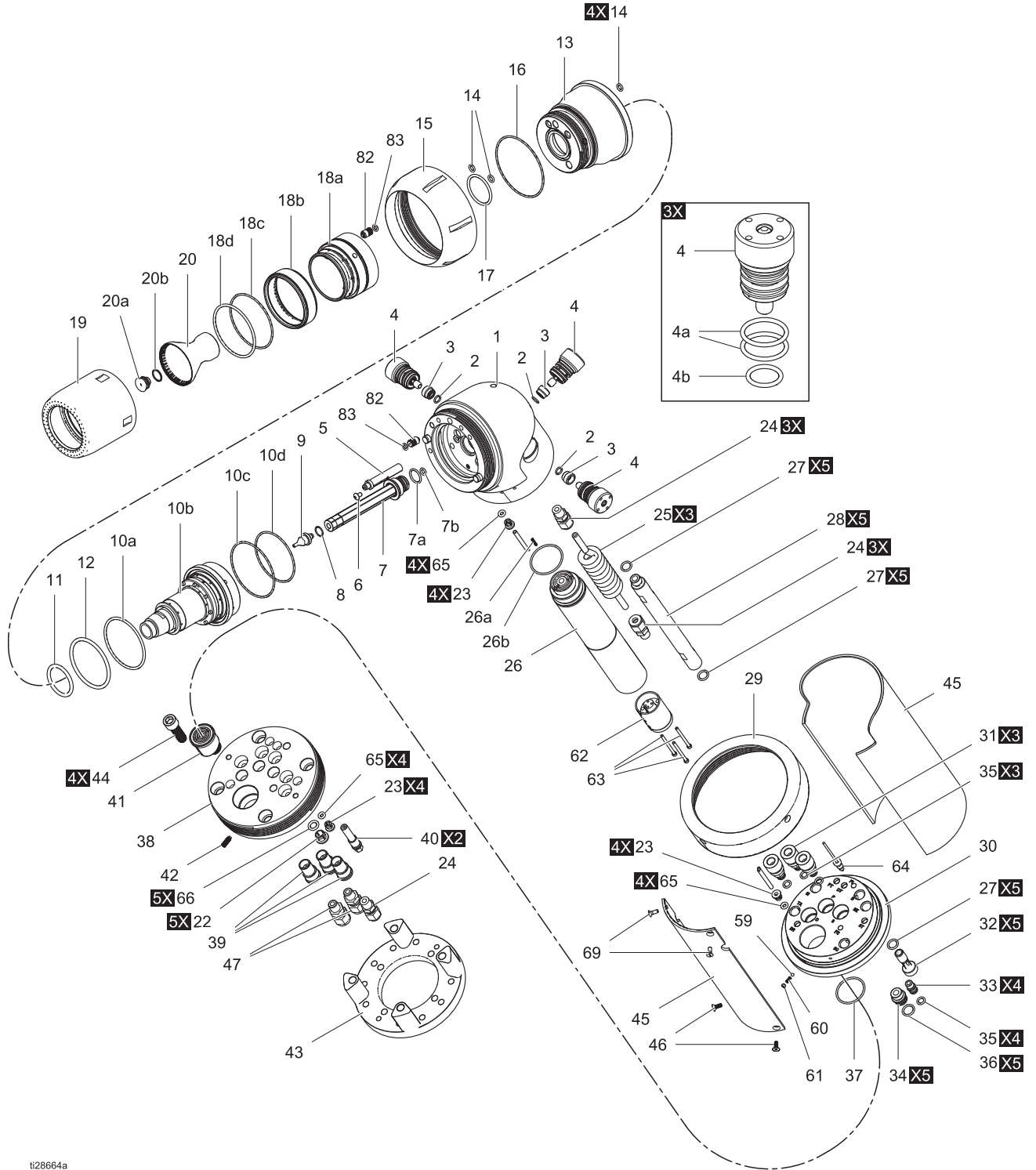

t28664a

## Parts for Solventborne Models (R\_A2\_0)

Ref.	Part	Description	Qty
1†	-----	HOUSING, main, assembly	1
2†	127316	O-RING, FX75	3
3†	25C242	SEAT, fluid valve; includes o-ring (Ref. 2)	3
4†	25C243	VALVE, fluid; includes seat (Ref. 3)	3
4a†	117610	O-RING, FX75	6
4b†	120775	O-RING, FX75	3
5	25C279	SENSOR, magnetic; includes screw (Ref. 6)	1
6	GC0612	SCREW, button head, #8-32 x 0.25	1
7	25C280	FLUID TUBE, assembly; includes o-rings (Refs. 7a, 7b)	1
7a	120776	O-RING, FX75	1
7b	111516	O-RING, FX75	1
8	17B390	O-RING, FX75	1
9		NOZZLE, fluid; includes o-ring (Ref. 8)	1
	25C206	0.75 mm. (0.03 in); for R_A23_ models	
	25C207	1 mm. (0.04 in); for R_A24_ models	
	25C208	1.25 mm (0.05 in); or R_A25_ models	
	25C209	1.5 mm (0.06 in); for R_A26_ models	
	26A524	1.8 mm (0.07 in)	
	26A525	2.0 mm (0.08 in)	
10	24W988	TURBINE, assembly; includes o-rings (Refs. 10a-10c)	1
10a◆	17D878	O-RING, FX75	1
10b◆	17B495	O-RING, FX75	1
10c◆	17D877	O-RING, FX75	1
11◆	GC1936	O-RING, FX75	1
12◆	17D879	O-RING, FX75	1
13	25C281	HOUSING, front; includes o-rings (Refs. 11, 12, 14, 16, 17)	1
14◆	111516	O-RING, FX75	6
15	25C218	RING, retaining	1
16◆	17B495	O-RING, FX75	1
17◆	125249	O-RING, FX75	1
18		AIR CAP, assembly; includes solvent stud (82) and o-ring (83)	1
	24Z989	for R1A2_ models (15 mm); includes Refs. 18a-18c	
	25C220	for R3A2_ models (30 mm); includes Refs. 18a-18c	
	25C221	for R5A2_ models (50 mm); includes Refs. 18a-18d	
18a	-----	AIR CAP, inner	1
18b	-----	AIR CAP, outer	1

Ref.	Part	Description	Qty
18c◆		O-RING	1
	17D877	O-RING - 30 mm	
	17S113	O-RING - 15 mm	
18d◆	17B494	O-RING	1
19		COVER, air cap	1
	24Z985	for R1A2_ models (15 mm)	
	25C223	for R3A2_ models (30 mm)	
	25C224	for R5A2_ models (50 mm)	
20		CUP, aluminum, serrated, includes splash plate (Ref. 20a); <i>see Cup Selection Charts, page 77, for available cups</i>	1
	24Z088	for R1A2_0 models (15 mm)	
	24Z079	for R3A2_0 models (30 mm)	
	24Z084	for R5A2_0 models (50 mm)	
20a		PLATE, splash	1
	25D455	for R1A2_0 models (15 mm); includes o-ring (Ref. 20c)	
	25C214	for R3A2_0 and R5A2_0 models; (30 mm and 50 mm) includes split ring (Ref. 20b)	
20b	17A653	RING, split	1
20c	17B390	O-RING, FX75	1
21	25C438	TOOL, 15 mm splash plate (not shown)	
22★	-----	RETAINER, tubing, 5/16 in; <i>see Kit 25C226, page 76</i>	5
23†★	-----	RETAINER, tubing, 5/32 in; <i>see Kit 25C226, page 76</i>	12
24†★	111157	FITTING, tube, 1/4 in. with 1/8 in. npt threads; <i>see Kit 25C225, page 76</i>	3
25	25C227	TUBE, coiled, 1/4 in.	1
26	25A692	POWER SUPPLY; includes spring (Ref. 26a) and o-ring (Ref. 26b)	1
26a	24Y773	SPRING	1
26b	16D531	O-RING, FX75	1
27	111316	O-RING, FX75	15
28	25C228	ROD, TIE	5
29	25C230	RING, quick disconnect	1
30	26A345	BASE, applicator	1
31	-----	INSERT, fluid, <i>see Kit 25C377, page 76</i>	1
32	17B738	SCREW, air port, 3/8-24 x 1/5 in.	5
33	-----	FITTING, air, 4mm; <i>see Kit 25C378, page 76</i>	4
34	-----	FITTING, air, 8 mm; <i>see Kit 25C378, page 76</i>	5
35◆	111450	O-RING, FX75	7
36◆	111507	O-RING, FX75	5
37◆	16N901	O-RING, FX75	1
38★	24Z265	BASE, robot	1

Ref.	Part	Description	Qty
39★	25C379	INSERT, fluid	3
40★	17J810	INSERT, fiber optic	2
41★	24Y382	CONNECTOR, power supply	1
42★	127347	SCREW, sockethead, 10-24 x 0.5 in.	1
43★	17K147	SPACER, robot base	1
44★	-----	SCREW, socket head, 3/8-16 x 1.25 in.	4
45	25C217	SHROUD	1
46	123910	SCREW, flat head, 6-32 x 0.375 in.	2
47★	17K719	FITTING, tube, 5/16 in. with 1/8 in. npt threads	2
52‡	25C199	TOOL, spanner wrench	1
53‡	25C200	TOOL, fluid valve	1
59	-----	BALL, sst; <i>see Kit 25C381, page 76</i>	1
60	-----	SPRING, compression; <i>see Kit 25C381, page 76</i>	1
61	-----	SCREW, set, #8-32 x 1/8 in.; <i>see Kit 25C381, page 76</i>	1
62	25C380	ADAPTER, spring pin; includes screws (Ref. 63)	1
63	-----	SCREW, 4-40 x 1 1/2	3
64	25C316	CABLE, fiber optic, extension	1
64a	-----	NUT, fiber optic - see kit 24W872	2
64b	-----	FITTING, fiber optic - see kit 24W872	2
65†★	17L763	O-RING, FX75	12
66★	17L764	O-RING, FX75	5
67	-----	COVER, gun; <i>not shown, (Kit 24Z176, qty. 10)</i>	1
68▲	17L835	SIGN, safety	1
69	17M122	SCREW, 6-32 x 0.375 in.	2
71‡	-----	TOOL, wrench, allen, 3/32 in.	1
72‡	-----	TOOL, wrench, allen, 5/32 in.	1
73‡*	-----	TOOL, wrench, allen, 3/16 in.	1
74‡	-----	TOOL, wrench, allen, 1/4 in.	1
74‡	-----	TOOL, wrench, allen, 5/16 in.	1
75‡	-----	TOOL, wrench, allen, 5/64 in.	1
76‡	-----	TOOL, wrench, allen, 7/32 in.	1
77‡	116553	GREASE, dielectric, tube	1
80▲	179791	TAG, warning	1
82†	25C283	STUD, solvent; includes o-rings (Ref. 83)	1
83†◆	112319	O-RING, FX75	2

‡ Parts are included in Tool Kit 25C198. (Not Shown)

\* Used on Standard gun only.

† Parts are included in Main Housing Kit 25C258

◆ See also O-Ring Kits 25C210, 25C211, 25C212, and 25C213.

★ Parts are included in Kit 24Z265, Robot Base with Fittings, for Solventborne Models.

▲ Replacement Danger and Warning labels, tags, and cards are available at no cost.



## Parts for Waterborne Models (R\_A2\_8)

Ref.	Part	Description	Qty
1†	-----	HOUSING, main, assembly	1
2†	127316	O-RING, FX75	3
3†	25C242	SEAT, fluid valve; includes o-ring (Ref. 2)	3
4†	25C243	VALVE, fluid; includes seat (Ref. 3)	3
4a†	117610	O-RING, FX75	6
4b†	120775	O-RING, FX75	3
5	25C279	SENSOR, magnetic; includes screw (Ref. 6)	1
6	GC0612	SCREW, button head, #8-32 x 0.25	1
7	25C280	FLUID TUBE, assembly; includes o-rings (7a,7b)	1
7a	120776	O-RING, FX75	1
7b	111516	O-RING, FX75	1
8	17B390	O-RING, FX75	1
9		NOZZLE, fluid; includes o-ring (Ref. 8)	1
	25C206	0.75 mm. (0.03 in); for R_A23_ models	
	25C207	1 mm. (0.04 in); for R_A24_ models	
	25C208	1.25 mm (0.05 in); or R_A25_ models	
	25C209	1.5 mm (0.06 in); for R_A26_ models	
	26A524	1.8 mm (0.07 in)	
	26A525	2.0 mm (0.08 in)	
10	24W988	TURBINE, assembly; includes o-rings (10a-10c)	1
10a◆	17D878	O-RING, FX75	1
10b◆	17B495	O-RING, FX75	1
10c◆	17D877	O-RING, FX75	1
11◆	GC1936	O-RING, FX75	1
12◆	17D879	O-RING, FX75	1
13	25C281	HOUSING, front; includes o-rings (Refs. 11, 12, 14, 16, 17)	1
14◆	111516	O-RING, 0.35 in (9 mm) OD	6
15	25C218	RING, retaining	1
16◆	17B495	O-RING, FX75	1
17◆	125249	O-RING, FX75	1
18		AIR CAP, assembly; includes solvent stud (82) and o-ring (83)	1
	24Z989	for R1A2_ _ models (15 mm); includes Refs. 18a-18c	
	25C220	for R3A2_ _ models (30 mm); includes Refs. 18a-18c	
	25C221	for R5A2_ _ models (50 mm); includes Refs. 18a-18d	
18a	-----	AIR CAP, inner	1
18b	-----	AIR CAP, outer	1

Ref.	Part	Description	Qty
18c◆		O-RING	1
	17D877	O-RING - 30 mm	
	17S113	O-RING - 15 mm	
18d◆	17B494	O-RING	1
19		COVER, air cap	1
	24Z985	for R1A2_ _ models (15 mm)	
	25C223	for R3A2_ _ models (30 mm)	
	25C224	for R5A2_ _ models (50 mm)	
20		CUP, aluminum, standard, serrated, includes splash plate (Ref. 20a) and tool (Ref. 21); <i>see Cup Selection Charts, page 77, for available cups</i>	1
	24Z088	for R1A2_ _ models (15 mm)	
	24Z079	for R3A2_ _ models (30 mm)	
	24Z084	for R5A2_ _ models (50 mm)	
20a		PLATE, splash	1
	25D455	for R1A2_ _ models (15 mm); includes o-ring (Ref. 20c)	
	25C214	for R3A2_ _ and R5A2_ _ models (30 mm and 50 mm); includes split ring (Ref. 20b)	
20b	17A653	RING, split	1
20c	17B390	O-RING, FX75	
21	25C438	TOOL, 15 mm splash plate	
22	-----	RETAINER, tubing, 5/16 in.; <i>see Kit 25C226, page 76</i>	5
23†	-----	RETAINER, tubing, 5/32 in.; <i>see Kit 25C226, page 76</i>	12
24†	111157	FITTING, tube, 1/4 in. with 1/8 in. npt threads; <i>see Kit 25C383, page 76</i>	2
25	25C227	TUBE, coiled, 1/4 in.	2
26	25A692	POWER SUPPLY; includes spring (Ref. 26a) and o-ring (Ref. 26b)	1
26a	24Y773	SPRING	1
26b	16D531	O-RING, FX75	1
27	111316	O-RING, FX75	17
28	25C228	ROD, TIE	5
29	25C230	RING, quick disconnect	1
30	26A345	BASE, applicator	1
31	-----	INSERT, fluid; <i>see Kit 25C377, page 76</i>	2
32	17B738	SCREW, air port, 3/8-24 x 1/5 in.	5
33	-----	FITTING, air, 4mm; <i>see Kit 25C378, page 76</i>	4
34	-----	FITTING, air, 8 mm; <i>see Kit 25C378, page 76</i>	5
35◆	111450	O-RING, FX75	5
36◆	111507	O-RING, FX75	5
37◆	16N901	O-RING, FX75	1
38	24Z265	BASE, robot	1

Parts

Ref.	Part	Description	Qty
39	25C379	INSERT, fluid, Qty. 3; <i>see also Kit 25C383, page 76</i>	1
40	17J810	INSERT, fiber optic	2
41	24Y382	CONNECTOR, power supply	1
42	127347	SCREW, sockethead, 10-24 x 0.5 in.	1
43	17K147	SPACER, robot base	1
44	127586	SCREW, socket head, 3/8-16 x 1.25 in.	4
45	25C217	SHROUD, includes screws (46, 69)	1
46	123910	SCREW, flat head, 6-32 x 0.375 in.	2
52‡	25C199	TOOL, spanner wrench	1
53‡	25C200	TOOL, fluid valve	1
59	-----	BALL, sst; <i>see Kit 25C381, page 76</i>	1
60	-----	SPRING, compression; <i>see Kit 25C381, page 76</i>	1
61	-----	SCREW, set, #8-32 x 1/8 in.; <i>see Kit 25C381, page 76</i>	1
62	25C380	ADAPTER, spring pin; includes screw (Ref. 63)	1
63	-----	SCREW, 4-40 x 1 1/2	3
64	25C316	CABLE, fiber optic, extension	1
64a	-----	NUT, fiber optic	1
64b	-----	FITTING, fiber optic	1
65†	17L763	O-RING, FX75	12
66	17L764	O-RING	5
67	-----	COVER, gun; <i>not shown, (Kit 24Z176, qty. 10)</i>	1
68▲	17L836	SIGN, warning	1
69	17M122	SCREW, 6-32 x 0.375 in.	2

Ref.	Part	Description	Qty
71‡	-----	TOOL, wrench, allen, 3/32 in.	1
72‡	-----	TOOL, wrench, allen, 5/32 in.	1
73‡	-----	TOOL, wrench, allen, 1/4 in.	1
74‡	-----	TOOL, wrench, allen, 5/16 in.	1
75‡	-----	TOOL, wrench, allen, 5/64 in.	1
76‡	-----	TOOL, wrench, allen, 7/32 in.	1
77‡	116553	GREASE, dielectric	1
78	-----	TOOL, wrench allen, 3/16 in.	1
80▲	179791	TAG, warning	1
82†	25C283	STUD, solvent; includes o-rings (Ref. 83)	1
83†◆	112319	O-RING	2
85	25C382	HOUSING, hose	2
86	-----	FITTING, strain relief; <i>see Kit 25C383, page 76</i>	2
87	17L670	FERRULE, hose; <i>see Kit 25C383, page 76</i>	2
88	17L671	NUT, hose; <i>see Kit 25C383, page 76</i>	2

- ▲ *Replacement Danger and Warning labels, tags, and cards are available at no cost.*
- † *Parts are included in Main Housing Kit 26A245.*
- ◆ *See also O-Ring Kits 25C210, 25C211, 25C212, and 25C213.*
- ‡ *Parts are included in Tool Kit 25C198.*

# Repair Kits

## Main Housing Repair Kits

### Kit 25C258, Main Housing Repair, Solventborne

Ref.	Description	Qty.
1	HOUSING, main, assembly	1
2	O-RING, FX75	3
3	SEAT, fluid valve	3
4	VALVE, fluid,	3
23	RETAINER, tubing, 5/32 in.	4
24	FITTING, tube, 1/4 in. with 1/8 in. npt threads	3
65	O-RING, FX75	4
82	STUD, solvent; includes o-rings (Ref. 83	1
83	O-RING, FX75	2

### Kit 26A245, Main Housing Repair, Waterborne

Ref.	Description	Qty.
1	HOUSING, main, assembly	1
2	O-RING, FX75	3
3	SEAT, fluid valve	3
4	VALVE, fluid,	3
23	RETAINER, tubing, 5/32 in.	4
24	FITTING, tube, 1/4 in. with 1/8 in. npt threads	1
65	O-RING, FX75	4
82	STUD, solvent; includes o-rings (Ref. 83	1
83	O-RING, FX75	2

### Kit 24Z265, Robot Base with Fittings, Solventborne

Ref.	Description	Qty.
22	RETAINER, tubing, 5/16 in.	5
23	RETAINER, tubing, 5/32 in.	4
24	FITTING, tube, 1/4 in. with 1/8 in. npt threads	1
38	BASE, robot	1
39	INSERT, fluid	3
40	INSERT, fiber optic	2
41	CONNECTOR, power supply	1
42	SCREW, sockethead, 10-24 x 0.5 in.	1
43	SPACER, robot base	1
44	SCREW, socket head, 3/8-16 x 1.25 in.	4
47	FITTING, tube, 5/16 x 1/8 npt	2
65	O-RING, FX75	4
66	O-RING, FX75	5

## O-Ring Kits

### Kit 25C210, Front Housing O-Rings

Ref.	Description	Qty.
11	O-RING, FX75	1
12	O-RING, FX75	1
14	O-RING, FX75	6
16	O-RING, FX75	1
17	O-RING, FX75	1

### Kit 25C212, Turbine O-Rings

Ref.	Description	Qty.
10a	O-RING, FX75	1
10b	O-RING, FX75	1
10c	O-RING, FX75	1

### Kit 25C213, Air Cap O-Rings (15 mm, 30 mm, 50 mm)

Ref.	Description	Qty.
18c	O-RING, FX75	1
18d	O-RING, FX75	1
83	O-RING, FX75	2

### Kit 25C211, Connection O-Rings

Ref.	Description	Qty.
35	O-RING, FX75	7
36	O-RING, FX75	5
37	O-RING, FX75	1

## Fittings and Tools

### Kit 25C377, Fluid Fittings, Applicator Base

Ref.	Description	Qty.
31	INSERT, fluid	3
35	O-RING, FX75	3

### Kit 25C225, Fluid Fittings, Robot Base, Solventborne

Ref.	Description	Qty.
24	FITTING, tube, 1/4 in. with 1/8 in. npt threads	4
47	FITTING, tube, 5/16 x 1/8 npt	2

### Kit 25C383, Fluid Fittings, Robot Base, Waterborne

Ref.	Description	Qty.
24	FITTING, tube, 1/4 in. with 1/8 in. npt threads	1
39	INSERT, fluid	1
86	FITTING, strain relief	2
87	FERRULE, hose	2
88	NUT, hose	2

### Kit 25C378, Air Fittings, Quick Connect Applicator Base

Ref.	Description	Qty.
33	FITTING, air, 4 mm	4
34	FITTING, air, 8 mm	5
35	O-RING, FX75	4
36	O-RING, FX75	5

### Kit 25C226, Air Fittings, Quick Connect, Robot Base

Ref.	Description	Qty.
22	RETAINER, tubing, 5/16 in.	5
23	RETAINER, tubing, 5/32 in.	4
65	O-RING, FX75	4
66	O-RING, FX75	5

### Kit 25C381, Power Connector Screw, set

Ref.	Description	Qty.
59	BALL, sst	1
60	SPRING, compression	1
61	SCREW, set, #8-32 x 1/8 in.	1

### Kit 25C198, Tool Box

Ref.	Description	Qty.
52	TOOL, spanner wrench	1
53	TOOL, fluid valve	1
71	TOOL, wrench, allen, 3/32 in.	1
72	TOOL, wrench, allen, 5/32 in.	1
73	TOOL, wrench, allen, 1/4 in.	1
74	TOOL, wrench, allen, 5/16 in.	1
75	TOOL, wrench, allen, 5/64 in.	1
76	TOOL, wrench, allen, 7/32 in.	1
77	GREASE, dielectric	1
78	TOOL, wrench 3/16 in.	1

## Air Cap and Cover Sets

Purchase as a replacement or to convert one bell model to another size. Each Kit includes the Air Cap Assembly (Ref. 18) and the Air Cap Cover (Ref. 19).

### Kit 25C285, 15 mm, for R1A2\_\_ Models

### Kit 25C286, 30 mm, for R3A2\_\_ Models

### Kit 25C287, 50 mm, for R5A2\_\_ Models



## Cup Selection Charts

**NOTE:** Pattern shape and diameter are material dependent.

\* Indicates the cup that is installed on the applicators at the factory. Other kits must be purchased separately.

### 15 mm Cups

	<b>Kit 24Z086</b>	<b>Kit 24Z088*</b>	<b>24Z089</b>	<b>Kit 24Z087</b>
Edge Type	Smooth	Serrated	Serrated	Smooth
Material	Aluminum	Aluminum	Aluminum	Composite
Splash Plate (20a, included)	25D455	25D455	25D455	25D455
Finish	Standard	Standard	High-wear	None
Air Cap and Cover Kit	25C285			
Recommended Fluid Nozzles	25C206 (0.75 mm), 25C207 (1 mm), 25C208 (1.25 mm)			
Recommended Production Flow Rates	25-100 cc/min.			
Pattern Diameter Range	< 4 in. (< 10 cm)			

### 30 mm Cups

	<b>Kit 24Z076</b>	<b>Kit 24Z079*</b>	<b>24Z080</b>	<b>Kit 24Z078</b>
Edge Type	Smooth	Serrated	Serrated	Smooth
Material	Aluminum	Aluminum	Aluminum	Composite
Splash Plate (20a, included)	25C214	25C214	25C214	25C214
Finish	Standard	Standard	High-wear	None
Air Cap and Cover Kit	25C286			
Recommended Fluid Nozzles	25C206 (0.75 mm), 25C207 (1 mm), 25C208 (1.25 mm), 25C209 (1.5 mm)			
Recommended Production Flow Rates	25-400 cc/min.			
Pattern Diameter Range	4-12 in. (10-31 cm)			

### 50 mm Cups

	<b>Kit 24Z081</b>	<b>Kit 24Z084*</b>	<b>24Z085</b>	<b>Kit 24Z083</b>
Edge Type	Smooth	Serrated	Serrated	Smooth
Material	Aluminum	Aluminum	Aluminum	Composite
Splash Plate (20a, included)	25C214	25C214	25C214	25C214
Finish	Standard	Standard	High-Wear	None
Air Cap and Cover Kit	25C287			
Recommended Fluid Nozzles	25C207 (1 mm), 25C208 (1.25 mm), 25C209 (1.5 mm)			
Recommended Production Flow Rates	50-500 cc/min.			
Pattern Diameter Range	4-18 in. (10-46 cm)			

# Accessories

**Table 3. Robot Adapter Plates**

Adapter Plate	Robot	Bolt Circle	Mounting Screws	Locating Pin Circle	Locating Pins
24Y634	MOTOMAN EPX2050	102 mm (4.02 in)	6X M6 x 1.0	102 mm (4.02 in)	2X 4 mm
	ABB IRB 580				
	ABB IRB 5400				
24Y650	MOTOMAN EPX2700	102 mm (4.02 in)	6X M6 x 1.0	102 mm (4.02 in)	2X 5 mm
	MOTOMAN EPX2800				
	MOTOMAN EPX2900				
	KAWASAKI KE610L				
	KAWASAKI KJ264				
	KAWASAKI KJ314				
24Y769	FANUC P-50 and P-250	100 mm (3.94 in)	6X M5	100 mm (3.94 in)	1X 5 mm

## Fiber Optic Bulkhead Installation

### Stainless Steel Bulkhead

Accepts Graco fiber optic cable fittings. Fits 1/2 inch (13 mm) panel hole.

#### 24W876 Stainless Steel Bulkhead Installation

1. Drill a 1/2 in. to 9/16 in (12.7 mm to 14.2 mm) hole in booth wall or panel to allow bulkhead to pass through.
2. Fiber optic cable nut should be 0.31 in. (7.9 mm) from end of cable.
3. Insert bulkhead (6) into hole and attach nut (7) on either side. Thread in fiber optic cable fitting (2) until it bottoms out. Do not force cable further. Make sure cable marker numbers match to ensure proper communication.
4. Repeat for second side of communications.

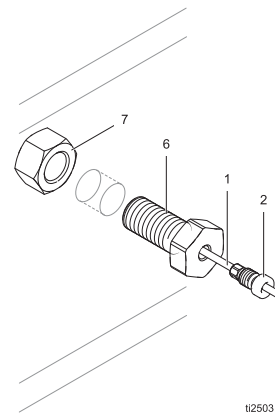

tj25031a

### Plastic Bulkhead

Accepts bare fiber optic cable. Fits 5/16" (8 mm) panel hole.

#### 24W877 Plastic Bulkhead Installation

1. Drill a 5/16 in. to 3/8 in (7.9 mm to 9.5 mm) hole in booth wall or panel to allow bulkhead to pass through.
2. Make a clean cut to the ends of the cable using fiber optic cutter tool. Ensure the ends of the cable are equal length.

3. Insert bulkhead (6) into hole and attach nut (7) on either side. Insert cable into bulkhead and tighten cinch nut down to a snug fit.
4. Repeat for second side of communications.

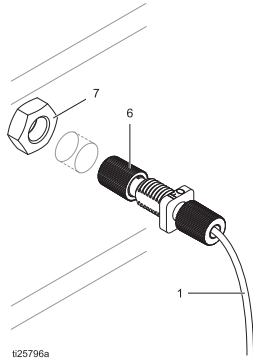

**Kit 25C288, Dump Valve Plug Kit**

Use to plug the dump passage in the applicator if a dump valve is not needed.

Part	Description	Qty
-----	PLUG	1
117610	O-RING, FX75	1
120775	O-RING, FX75	1
127316	O-RING, FX75	1

**Kit 24Z183, Reflective Speed Sensing Kit**

Replaces the magnetic speed sensor with a dual fiber, optical speed sensor (25A537) and fiber optic source. See manual 3A4738.

**Kit 25A537, Reflective Fiber Optic Cable Kit**

Dual fiber optical speed sensor only. Includes reflective fiber optic cable with housing and hardware required to install in a ProBell applicator.

**Dual Strand Fiber Optic Cables**

End nut must be adjusted to proper length for the applicator being used.

Part	Description	Qty
24X003	CABLE, fiber optic, 25 ft (7.6 m)	1
24X004	CABLE, fiber optic, 50 ft (15.25 m)	1
24X005	CABLE, fiber optic, 100 ft (30.5 m)	1

**Fiber Optic Cables, Hollow Wrist Models**

Standard single fiber.

Kit	Description	Qty
24Z193	CABLE, fiber optic, 36 ft (11 m)	1
24Z194	CABLE, fiber optic, 66 ft (20 m)	1
24Z195	CABLE, fiber optic, 99 ft (30 m)	1

**Kit 24W875, Fiber Optic Cable Repair**

Includes hardware to repair/replace all fiber optic ends.

Part	Description	Qty
-----	FITTING, fiber optic	4
-----	NUT, fiber optic	4
-----	TOOL, cutter, fiber optic	1

**Kit 24W823, Fiber Optic Cable Cutting Tool**

Use to get clean cut ends.

Part	Description	Qty
-----	TOOL, cutter, fiber optic	3

**Applicator Power Cables**

Kit	Description	Qty
17J586	CABLE, low voltage, 36 ft (11 m)	1
17J588	CABLE, low voltage, 20 m (66 ft.)	1
17J589	CABLE, low voltage, 30 m (99 ft.)	1

**Fiber Optic Bulkheads**

Use to run fiber through walls.

Kit	Description	Qty
24W876	STAINLESS STEEL BULKHEAD requires 24W875	2
24W877	PLASTIC BULKHEAD	2

**Waterborne Fluid Hose Kits (Shielded);**

**For Models R\_A2\_8**

100 psi (0.69 MPa, 6.9 bar) Maximum Working Pressure

Kit	Description	Qty
24Z199	HOSE, fluid, shielded, 36 ft (11 m)	1
24Z200	HOSE, fluid, shielded, 66 ft (20 m)	1

**Waterborne Fluid Hose Kits (Unshielded);**

**For Models R\_A2\_8**

100 psi (0.69 MPa, 6.9 bar) Maximum Working Pressure

Kit	Description	Qty
24Z201	HOSE, fluid, unshielded, 36 ft (11 m)	1
24Z202	HOSE, fluid, unshielded, 66 ft (20 m)	1

**Solventborne Hose Bundles;**

**For Models R\_A1\_0**

100 psi (0.69 MPa, 6.9 bar) Maximum Working Pressure

The hose bundle includes a fiber optic cable, power cables, a ground wire, nylon air lines, and PFA fluid lines.

Kit	Description	Qty
24Z168	HOSE BUNDLE, 36 ft (11 m)	1
24Z169	HOSE BUNDLE, 66 ft (20 m)	1
24Z170	HOSE BUNDLE, 99 ft (30 m)	1

**Air Only Hose Bundles**

The hose bundle includes a fiber optic cable, power cables, a ground wire, and nylon air lines.

Kit	Description	Qty
24Z711	HOSE BUNDLE, 36 ft (11 m)	1
24Z712	HOSE BUNDLE, 66 ft (20 m)	1
24Z713	HOSE BUNDLE, 99 ft (30 m)	1

**Hose Bundle Accessories**

Kit	Description	Qty
24Z662	WRAP, spiral, 7 in. (18 cm) section, bag of 10	10
17A490	WRAP, blue, sold per foot	up to 100 ft.

**Bulk Hose Tubing**

Maximum continuous purchase length is 100 ft., 30 m. 150 psi (1.03 MPa, 10.3 bar) Maximum Working Pressure

Kit	Description
057233*	5/16 in. OD x 1/4 in. ID PFA fluid hose
057234*	1/4 in. OD x 3/16 in. ID, PFA fluid hose
057231	5/16 in. nylon tubing
054754	5/32 in. nylon tubing, red
598095	5/32 in. nylon tubing, natural
054753	5/32 in. nylon tubing, black
054757	5/32 in. nylon tubing, green

\* *Not for use with high-voltage fluid.*

**Kit 25N020, Waterborne Isolated Solvent Line**

Includes the hardware required to replace the grounded solvent line with an isolated waterborne fluid hose. Additional waterborne fluid hoses must be purchased separately.

Part	Description	Qty
111507	PACKING, o-ring	1
25C382	TUBE, hose housing, waterborne	1
-----	FITTING, waterborne hose	1
17L670	FERRULE, waterborne hose	1
17L671	NUT, waterborne hose	1

**Kit 25C424, Grounding Plate****Kit 249598, Unclogging Needle**

Kit includes 12 picks for unclogging gun air covers or nozzles.

**Kit 24Z176, Gun Cover**

Kit includes 10 gun covers for the hollow wrist applicator.

**Test Equipment**

Part No.	Description
241079	Megohmmeter. 500 V output, 0.01–2000 megohms. Use for ground continuity and gun resistance tests. <b>Not for use in hazardous locations.</b>
722886	Paint Resistance Meter. Use for fluid resistivity test. See manual 307263. <b>Not for use in hazardous locations.</b>
722860	Paint Probe. Use for fluid resistivity test. See manual 307263. <b>Not for use in hazardous locations.</b>
245277	Test Fixture, High Voltage Probe, and kV Meter. Use to test the electrostatic voltage of the gun, and the condition of the power supply when being serviced. See manual 309455.

**Miscellaneous Equipment****Gun Accessories**

Part No.	Description
111265	Non-silicone Lubricant, 4 oz (113 g).
116553	Dielectric Grease. 1 oz (30 ml)

# Dimensions

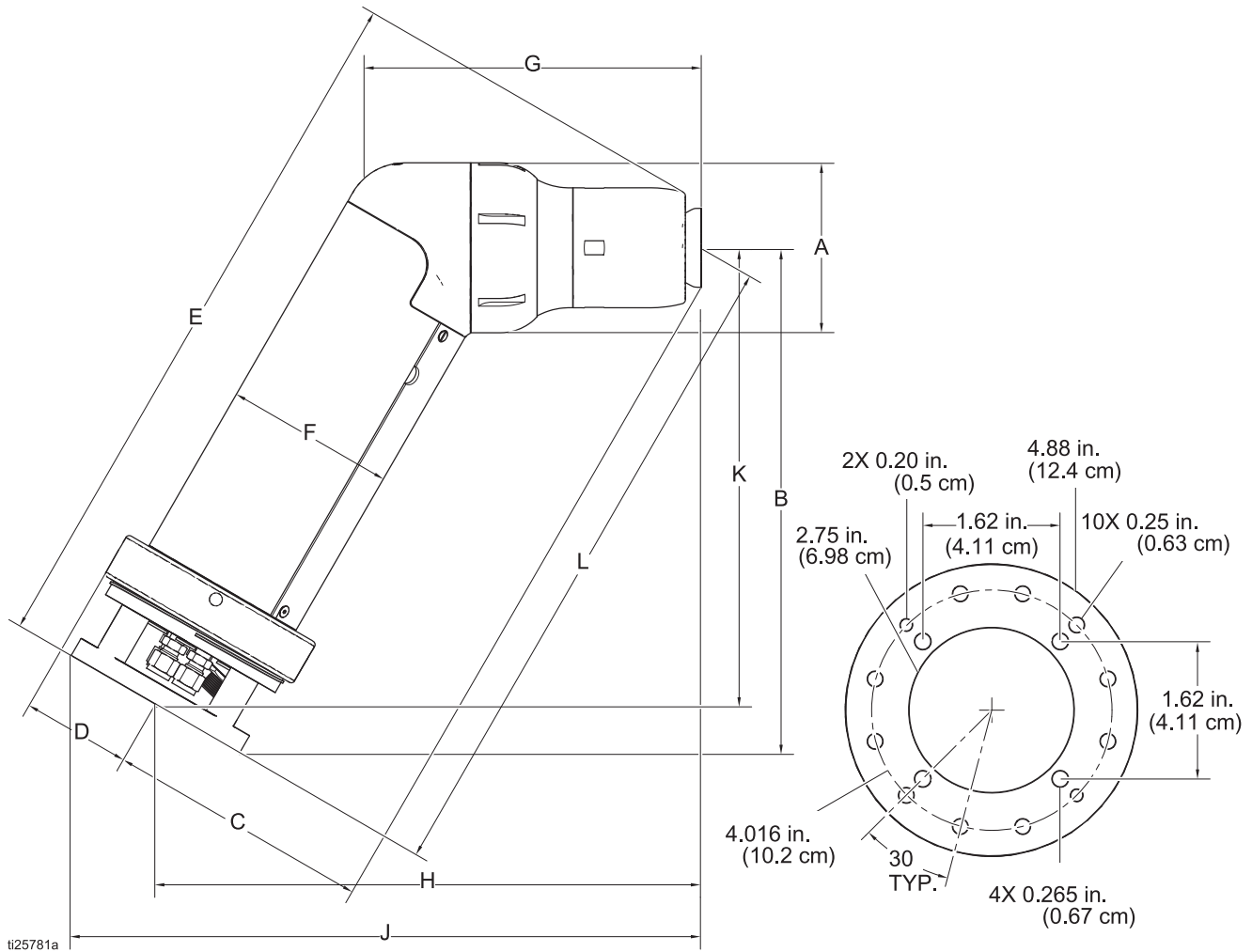

ti25781a

Ref.	Dimension					
	15 mm Cup		30 mm Cup		50 mm Cup	
	Inches	Centimeters	Inches	Centimeters	Inches	Centimeters
A	4.2	10.7	4.2	10.7	4.2	10.7
B	12.6	32.0	12.6	32.0	12.6	32.0
C	5.8	14.7	5.9	15.0	6.6	16.8
D	2.8	7.1	2.8	7.1	2.8	7.1
E	16.9	42.9	16.8	42.7	17.7	45.0
F	4.2	10.7	4.2	10.7	4.2	10.7
G	7.7	19.6	7.7	19.6	8.3	21.1
H	13.1	33.3	13.1	33.3	13.6	34.5
J	15.2	38.6	15.2	38.6	15.7	39.9
K	11.4	29.0	11.4	29.0	11.4	29.0
L	16.4	41.7	16.4	41.7	16.7	42.4

# Performance Charts

## Turbine Air Consumption Charts

These charts show the air consumption in scfm (l/min.) by rotation speed for the three cup sizes. See the key for the flow rate represented by each line.

### 15 mm KEY:

———— 100 cc/min.

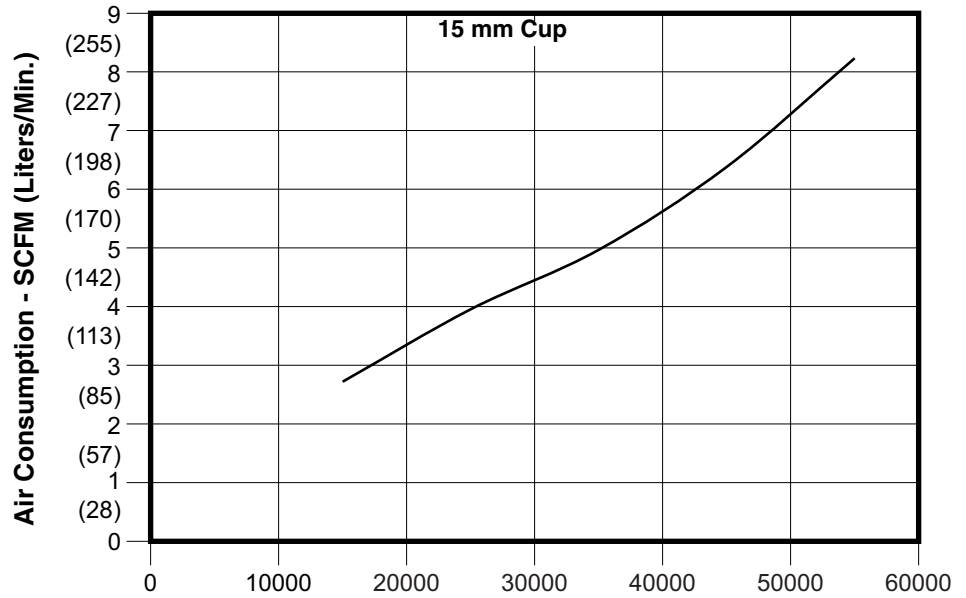

### 30 mm KEY:

———— 300 cc/min.

- - - - - 100 cc/min

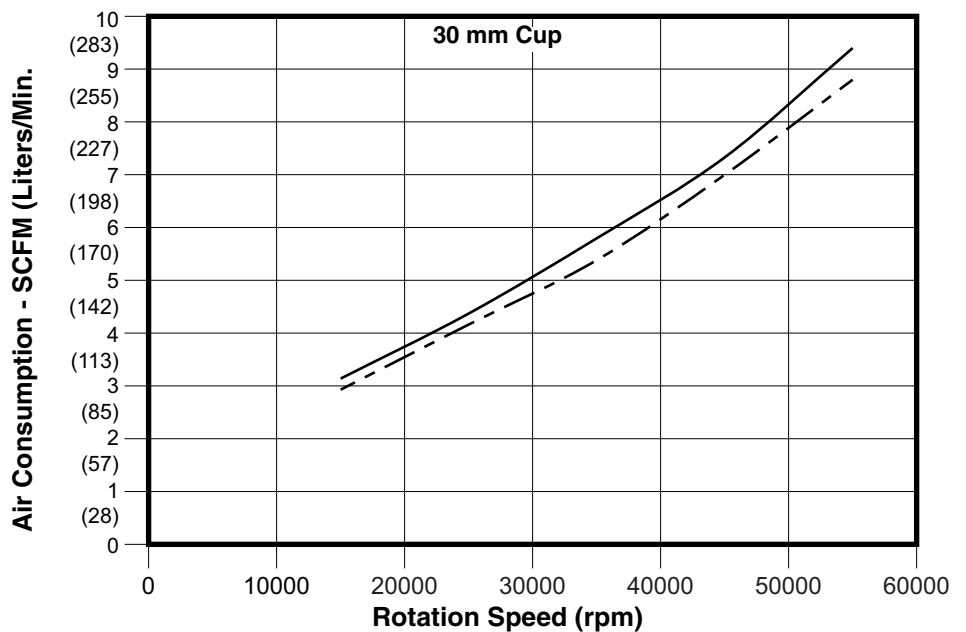

### Turbine Air Consumption Charts (continued)

**50 mm KEY:**

- 500 cc/min.
- - - - - 300 cc/min.
- · · · · 100 cc/min.

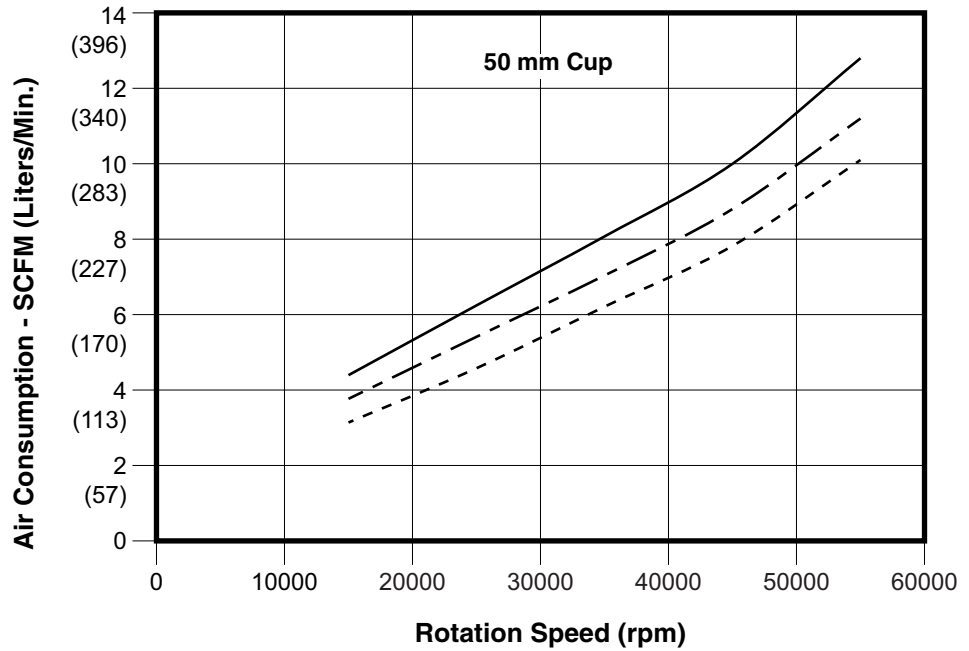

### Turbine Inlet Air Pressure Charts

These charts show the turbine inlet air pressure by rotation speed for the three cup sizes. See the key for the flow rate represented by each line. Pressure is measured within 1 ft (0.3 m) of the rotary applicator.

**KEY:**

- 100 cc/min.

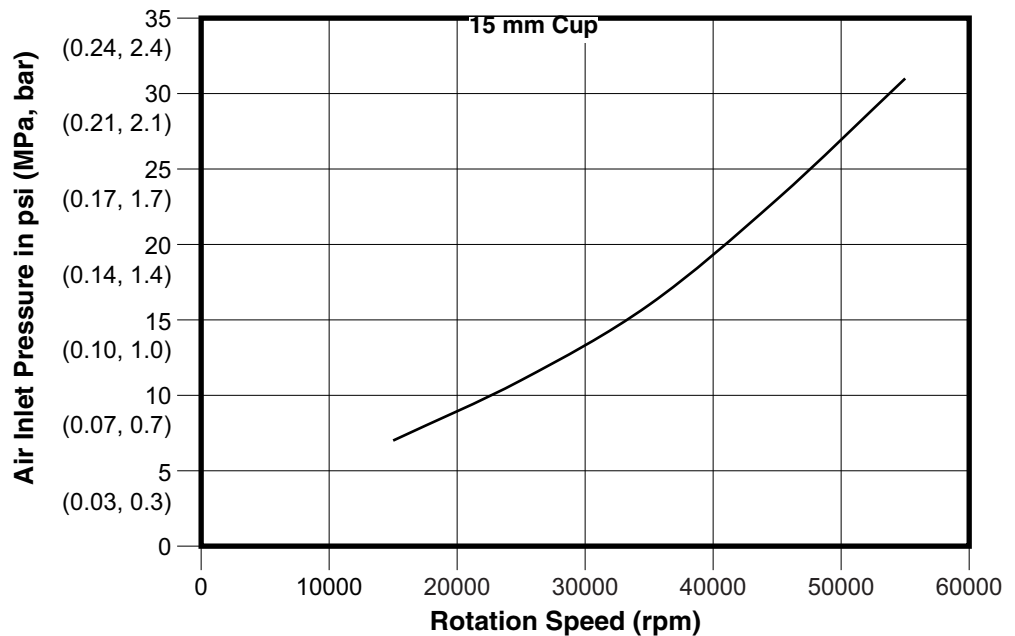



**Turbine Inlet Air Pressure Charts (continued)**

**30 mm KEY:**

- 100 cc/min.
- - - - - 300 cc/min.

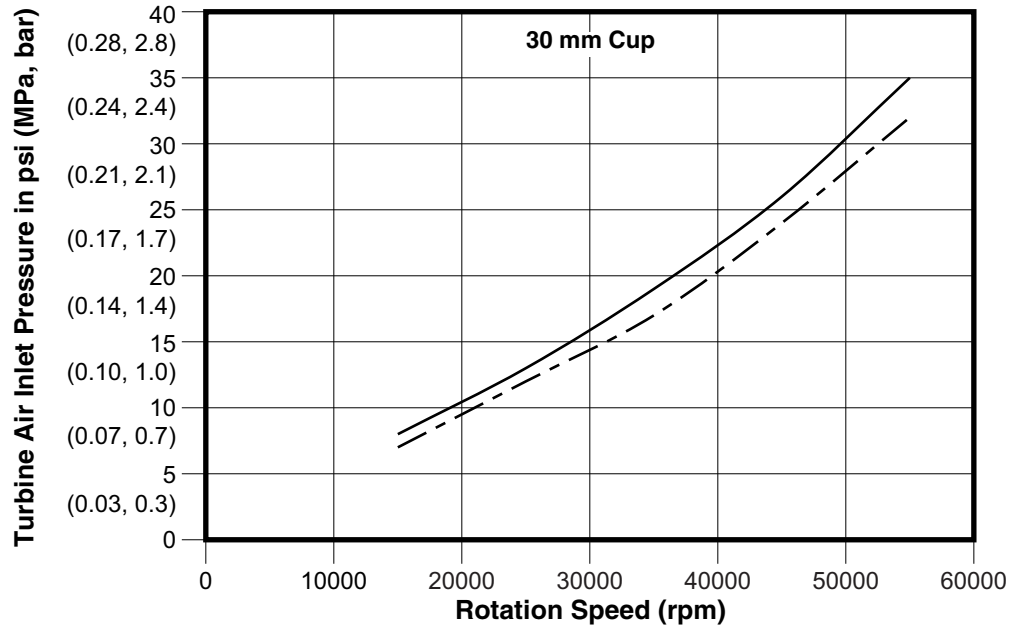

**50 mm KEY:**

- 100 cc/min.
- - - - - 300 cc/min.
- · - · - 500 cc/min.

- Limit for 20 m tube length. See note.
- Limit for 30 m tube length. See note.

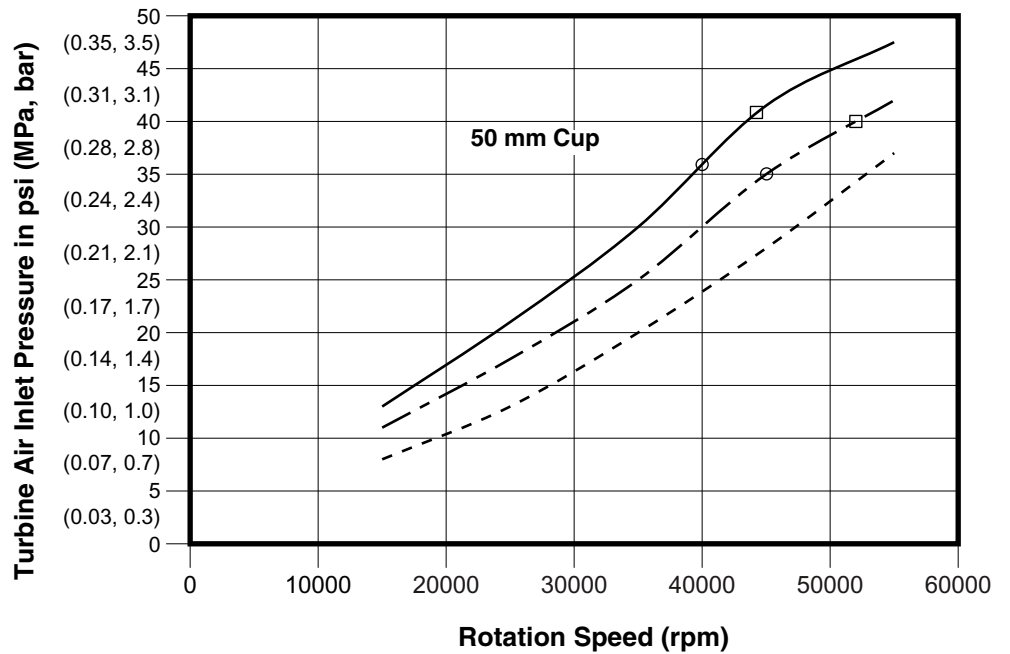

**NOTE:** The rotation speed or flow rate of a 50 mm cup may be limited due to pressure drop in the turbine air line. The limits for the 8 mm OD tube are shown in the chart above. 100 PSI (0.69 MPa, 7.0 bar) system inlet pressure is assumed. For the full range of performance, use one of the following options:

- a maximum of 11 m (35 ft) length of 8 mm OD tube with a 1 mm wall (0.3125 in. OD tube with 0.04 in. wall).
- a maximum of 30 m (100 ft) length of 10 mm OD tube with a 1 mm wall.
- a maximum of 30 m (100 ft) length of 0.375 in. OD tube with a 0.05 in. wall.

## Shaping Air Consumption Charts

These charts show shaping air consumption in scfm (liters per minute) for the three cup sizes. See the key for the type of shaping air (inner or outer) represented by each line. Pressure is measured within 1 ft (0.3 m) of the rotary applicator.

### 15 mm KEY:

—— Shaping air  
(inner and  
outer)

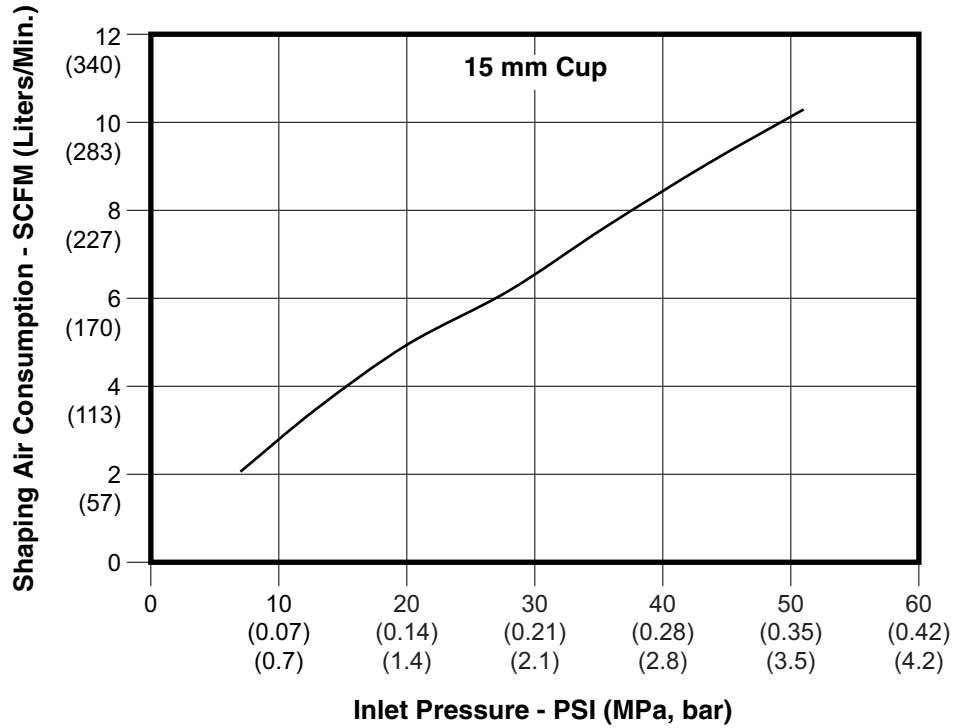

### 30 mm KEY:

—— Inner Shaping  
Air  
- - - - - Outer Shaping  
Air

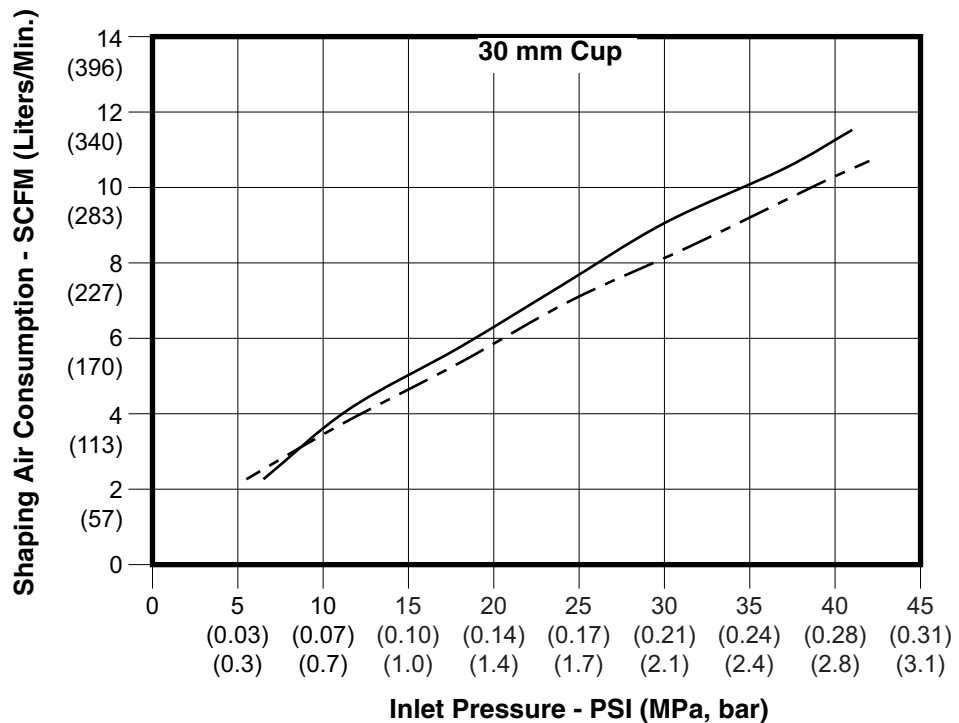

### Shaping Air Consumption Charts (continued)

**50 mm KEY:**

- Inner Shaping Air
- - - - - Outer Shaping Air

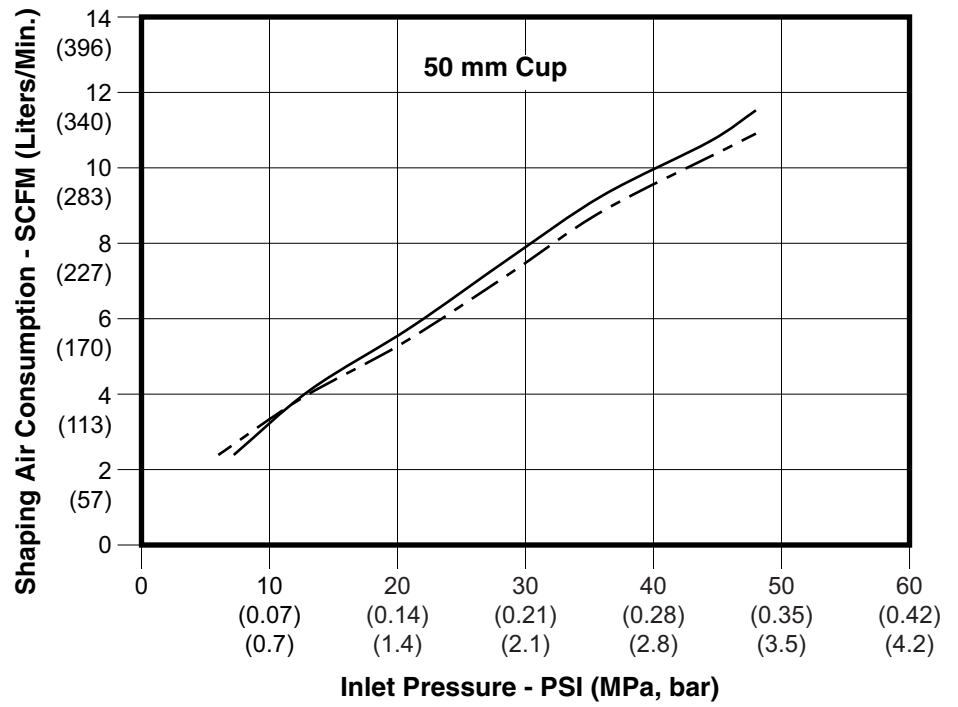

## Fluid Flow Rate Charts

These charts show fluid flow rates in cc/minute by inlet pressure for four nozzle sizes. See the key for the viscosity represented by each line. Pressure is measured within 1 ft (0.3 m) of the rotary applicator.

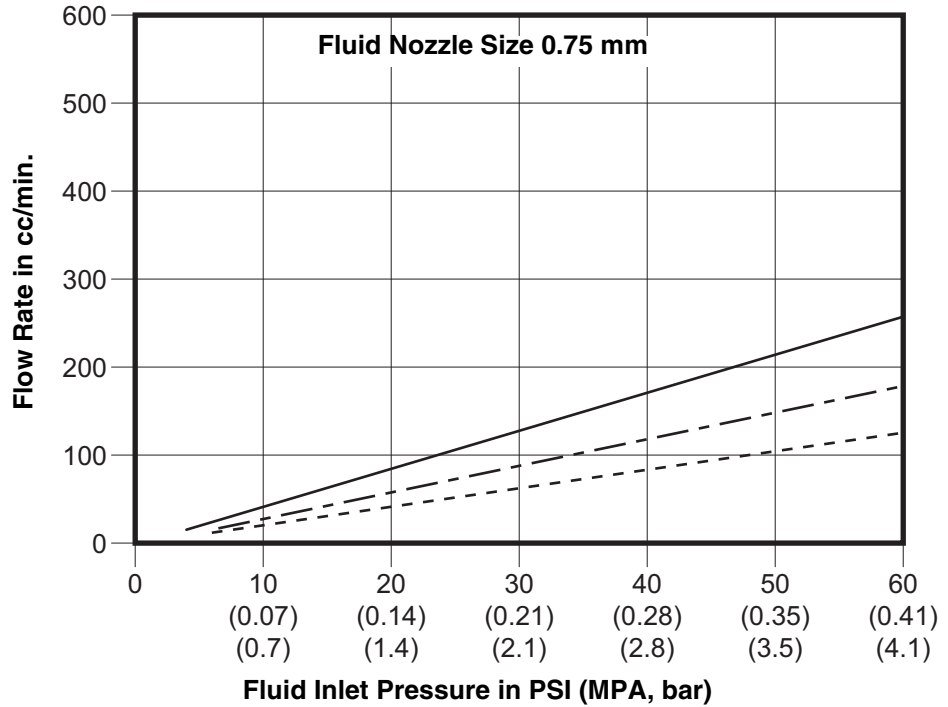

**KEY:**

- 50 cps
- - - - - 100 cps
- ..... 150 cps

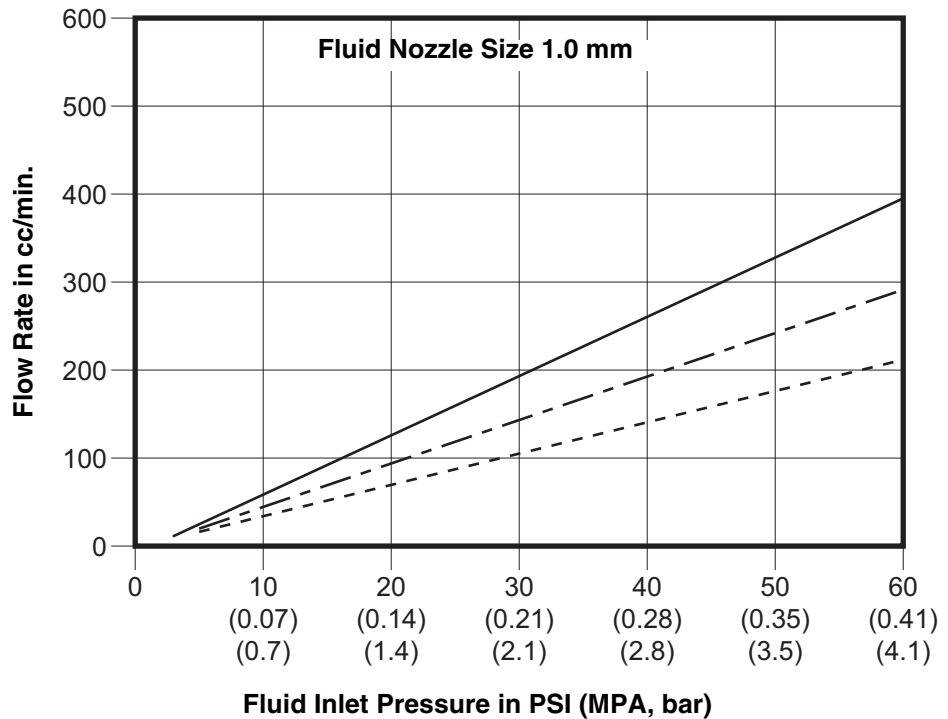

Fluid Flow Rate Charts (Continued)

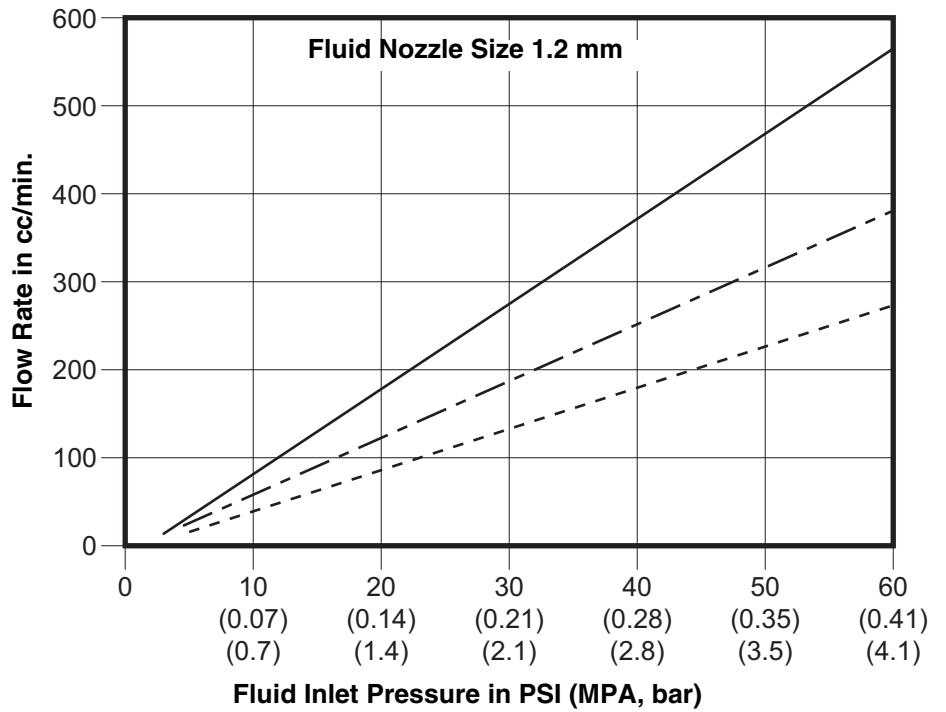

**KEY:**

———— 50 cps

----- 100 cps

..... 150 cps

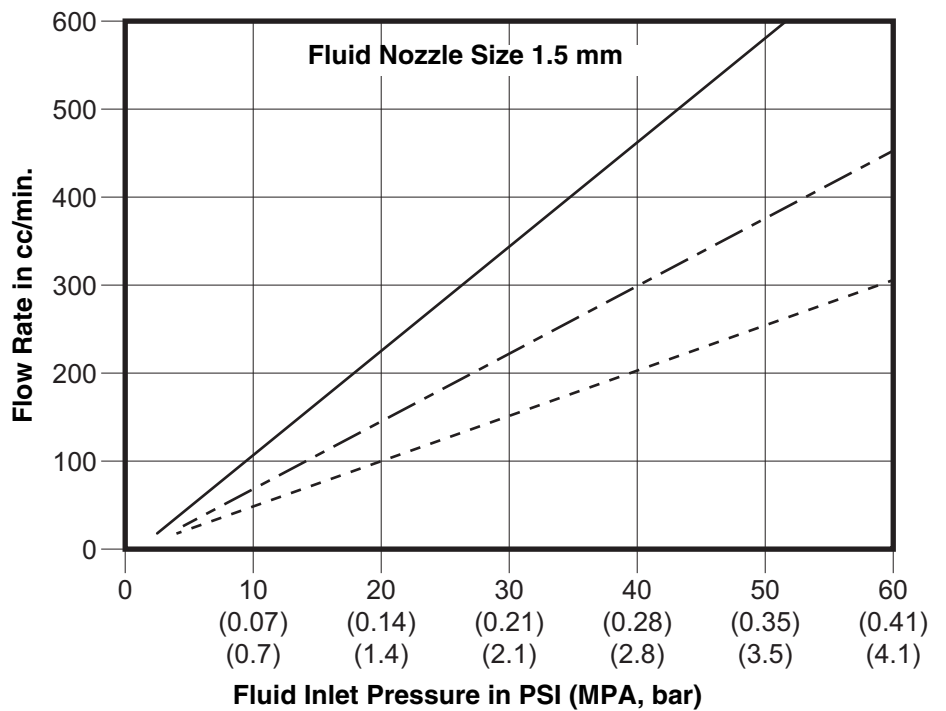

**Fluid Flow Rate Charts (Continued)**

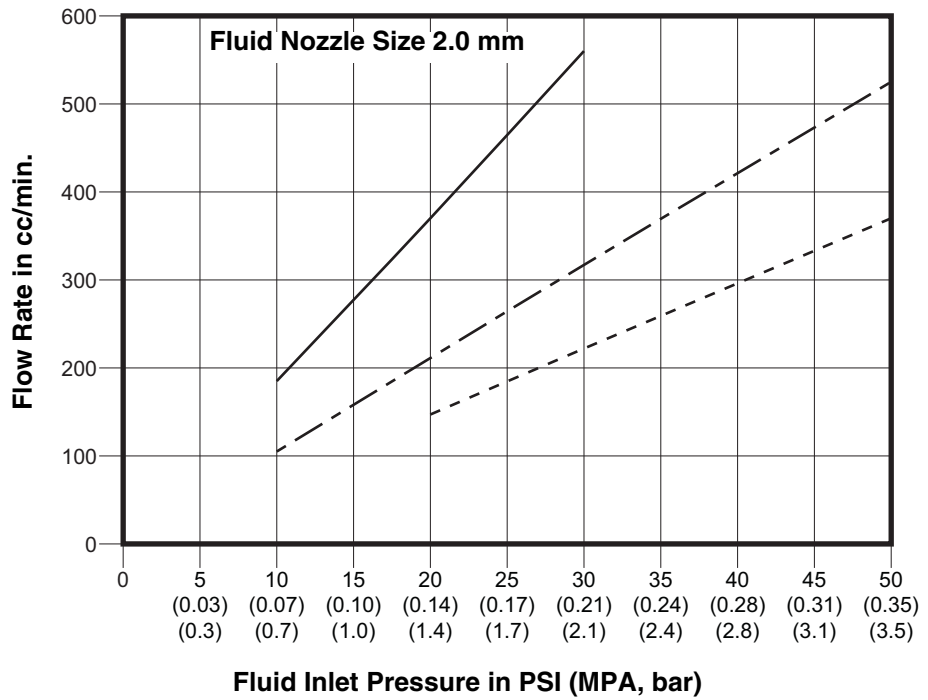
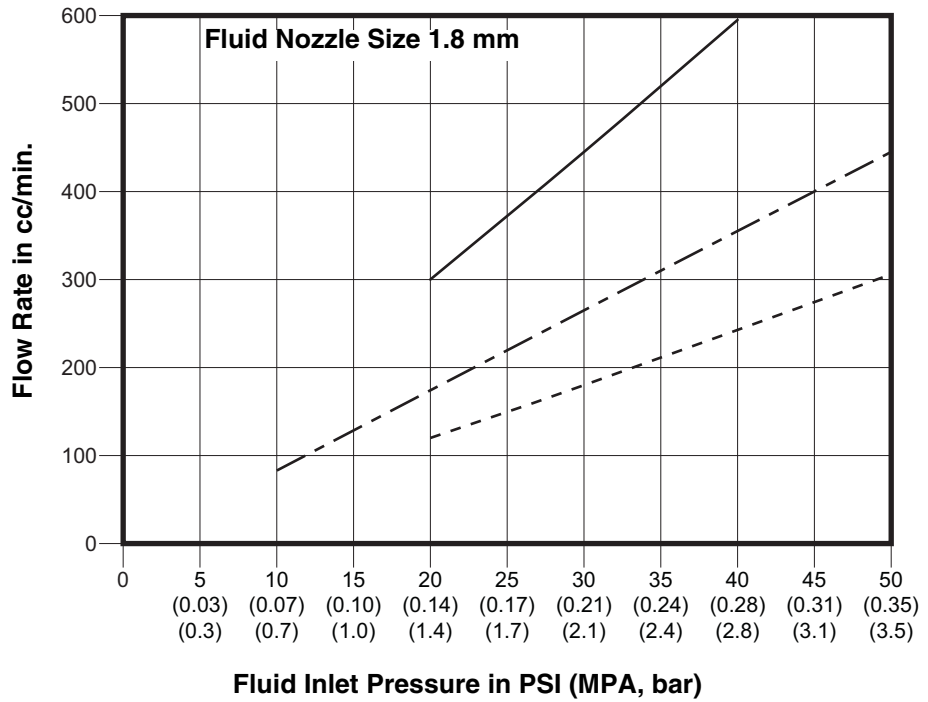

## Pressure Loss Charts

These charts show the pressure loss per foot of hose in psi (MPa, bar) for three hose sizes. See the key for the viscosity represented by each line.

**KEY:**

- 150 cps
- - - - - 100 cps
- ..... 50 cps

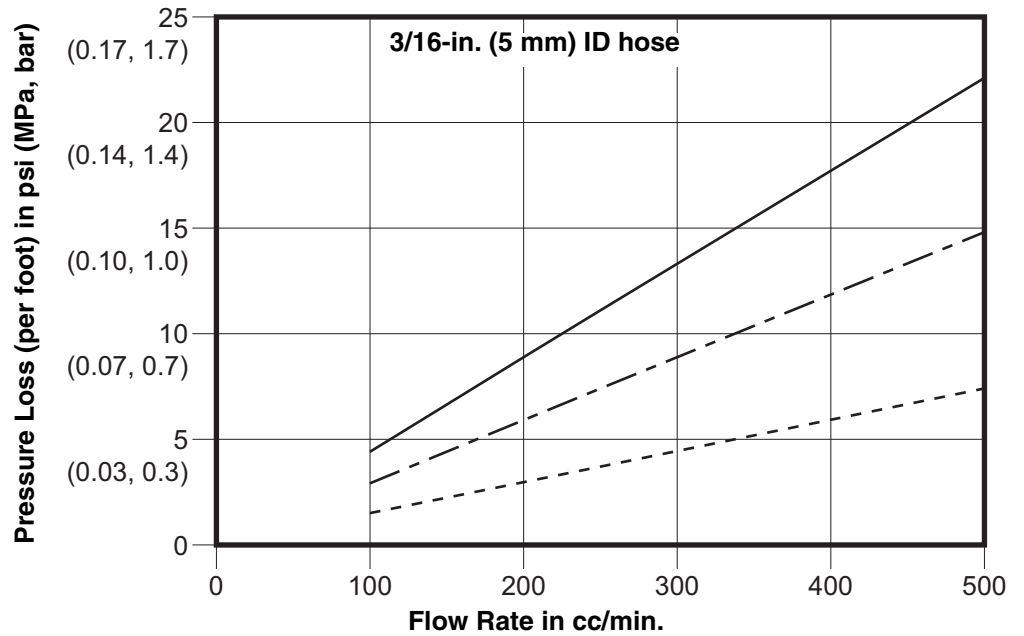
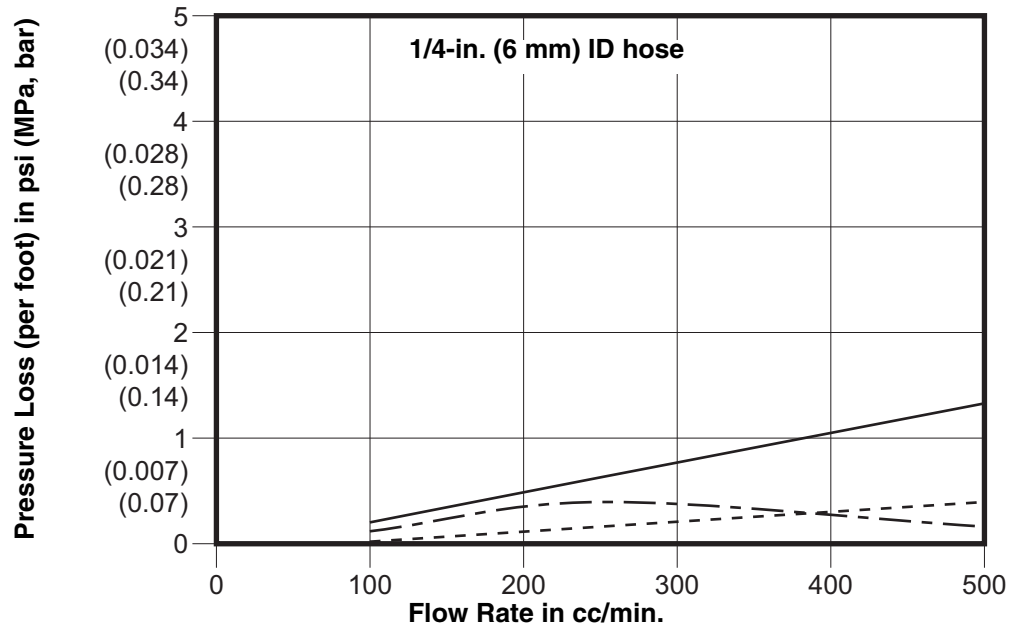

### Pressure Loss Charts (Continued)

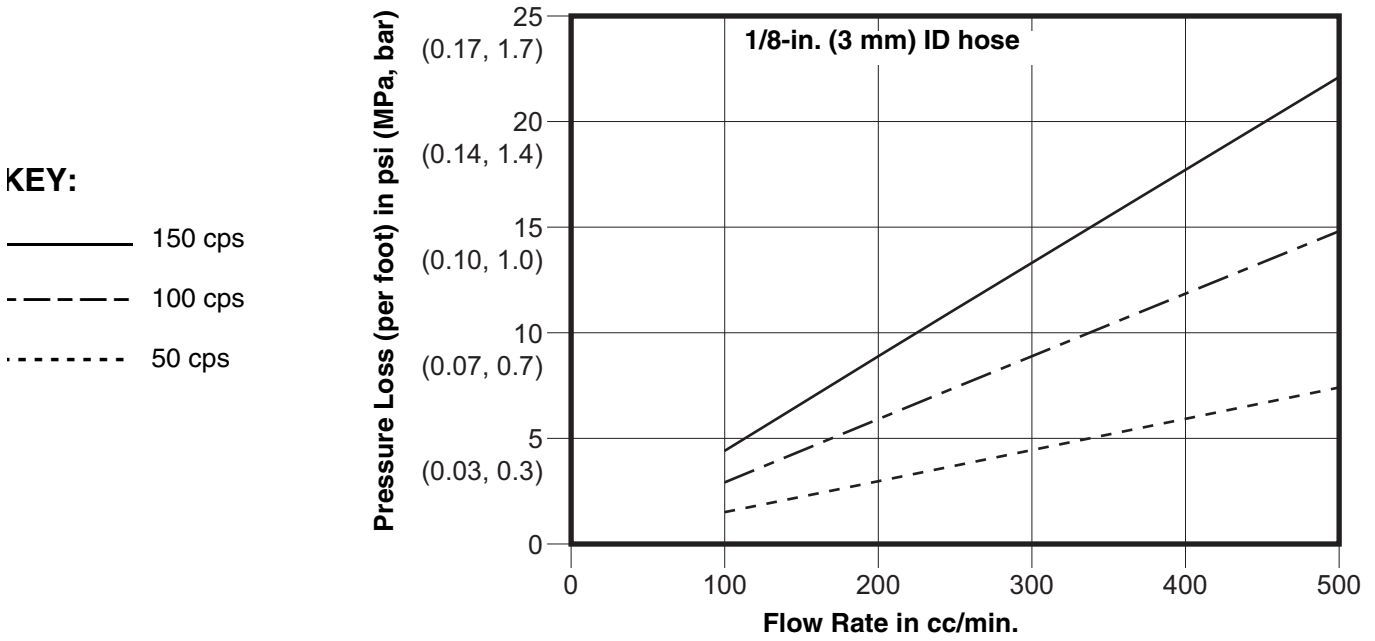



# Technical Specifications

<b>ProBell Rotary Applicator</b>		
	<b>US</b>	<b>Metric</b>
Maximum air working pressure	100 psi	0.69 MPa, 7.0 bar
Maximum air consumption	50 scfm (25 scfm is typical)	
Bearing air - minimum required	70 psi	0.5 MPa, 5.0 bar
Turbine and bearing air conditions		
Maximum dew point	10° F	- 12° C
Aerosol limit	99% aerosol free	
Maximum particle size	.00002 inches	0.5 microns
Maximum air and fluid temperature	120°F	49°C
Maximum fluid working pressure	150 psi	1.03 MPa, 10.3 bar
Turbine speed - maximum operating	60,000 rpm	
Viscosity Range	30 - 150 centistokes	
Maximum flow rate, 50 mm cup	500 cc/min	
Maximum flow rate, 30 mm cup	400 cc/min	
Maximum flow rate, 15 mm cup	100 cc/min	
Paint resistivity range	Solventborne systems: 1 megohm-cm to infinity Waterborne systems: Conductive waterborne fluids	
Weight	13.5 lbs (6 kg)	
Maximum output voltage	Solventborne systems: 100 kV Waterborne systems: 60 kV	
Maximum current draw	150 micro-amperes	
Sound pressure level at 60 kRPM, 70 psi (0.48 MPa, 4.8 bar); measured per ISO 9614-2, 1 m from applicator	77 dB(A)	
Ambient temperature range	41° F to 104° F	5° C to 40° C
Wetted parts	acetal, 300 series stainless steel, fluoroelastomer, coated aluminum, nylon, PTFE, PEEK	

# Graco Standard Warranty

Graco warrants all equipment referenced in this document which is manufactured by Graco and bearing its name to be free from defects in material and workmanship on the date of sale to the original purchaser for use. With the exception of any special, extended, or limited warranty published by Graco, Graco will, for a period of twelve months from the date of sale, repair or replace any part of the equipment determined by Graco to be defective. This warranty applies only when the equipment is installed, operated and maintained in accordance with Graco's written recommendations.

This warranty does not cover, and Graco shall not be liable for general wear and tear, or any malfunction, damage or wear caused by faulty installation, misapplication, abrasion, corrosion, inadequate or improper maintenance, negligence, accident, tampering, or substitution of non-Graco component parts. Nor shall Graco be liable for malfunction, damage or wear caused by the incompatibility of Graco equipment with structures, accessories, equipment or materials not supplied by Graco, or the improper design, manufacture, installation, operation or maintenance of structures, accessories, equipment or materials not supplied by Graco.

This warranty is conditioned upon the prepaid return of the equipment claimed to be defective to an authorized Graco distributor for verification of the claimed defect. If the claimed defect is verified, Graco will repair or replace free of charge any defective parts. The equipment will be returned to the original purchaser transportation prepaid. If inspection of the equipment does not disclose any defect in material or workmanship, repairs will be made at a reasonable charge, which charges may include the costs of parts, labor, and transportation.

**THIS WARRANTY IS EXCLUSIVE, AND IS IN LIEU OF ANY OTHER WARRANTIES, EXPRESS OR IMPLIED, INCLUDING BUT NOT LIMITED TO WARRANTY OF MERCHANTABILITY OR WARRANTY OF FITNESS FOR A PARTICULAR PURPOSE.**

Graco's sole obligation and buyer's sole remedy for any breach of warranty shall be as set forth above. The buyer agrees that no other remedy (including, but not limited to, incidental or consequential damages for lost profits, lost sales, injury to person or property, or any other incidental or consequential loss) shall be available. Any action for breach of warranty must be brought within two (2) years of the date of sale.

**GRACO MAKES NO WARRANTY, AND DISCLAIMS ALL IMPLIED WARRANTIES OF MERCHANTABILITY AND FITNESS FOR A PARTICULAR PURPOSE, IN CONNECTION WITH ACCESSORIES, EQUIPMENT, MATERIALS OR COMPONENTS SOLD BUT NOT MANUFACTURED BY GRACO.** These items sold, but not manufactured by Graco (such as electric motors, switches, hose, etc.), are subject to the warranty, if any, of their manufacturer. Graco will provide purchaser with reasonable assistance in making any claim for breach of these warranties.

In no event will Graco be liable for indirect, incidental, special or consequential damages resulting from Graco supplying equipment hereunder, or the furnishing, performance, or use of any products or other goods sold hereto, whether due to a breach of contract, breach of warranty, the negligence of Graco, or otherwise.

## **FOR GRACO CANADA CUSTOMERS**

The Parties acknowledge that they have required that the present document, as well as all documents, notices and legal proceedings entered into, given or instituted pursuant hereto or relating directly or indirectly hereto, be drawn up in English. Les parties reconnaissent avoir convenu que la rédaction du présente document sera en Anglais, ainsi que tous documents, avis et procédures judiciaires exécutés, donnés ou intentés, à la suite de ou en rapport, directement ou indirectement, avec les procédures concernées.

# Graco Information

For the latest information about Graco products, visit [www.graco.com](http://www.graco.com).

For patent information, see [www.graco.com/patents](http://www.graco.com/patents).

**TO PLACE AN ORDER**, contact your Graco distributor or call to identify the nearest distributor.

**Phone:** 612-623-6921 **or Toll Free:** 1-800-328-0211 **Fax:** 612-378-3505

*All written and visual data contained in this document reflects the latest product information available at the time of publication. Graco reserves the right to make changes at any time without notice.*

Original instructions. This manual contains English. MM 334626

**Graco Headquarters:** Minneapolis

**International Offices:** Belgium, China, Japan, Korea

**GRACO INC. AND SUBSIDIARIES • P.O. BOX 1441 • MINNEAPOLIS MN 55440-1441 • USA**  
**Copyright 2016, Graco Inc. All Graco manufacturing locations are registered to ISO 9001.**

[www.graco.com](http://www.graco.com)

Revision G, April 2018