

Volumetric Fluid Flow Meter

308778Y

EN

**For precise metering of plural component fluids or solvents (depending on model).
For professional use only.**

See page 3 for model information, including maximum working pressure.



Important Safety Instructions

Read all warnings and instructions in this manual. Save these instructions.

G3000, G3000A, and G3000HR

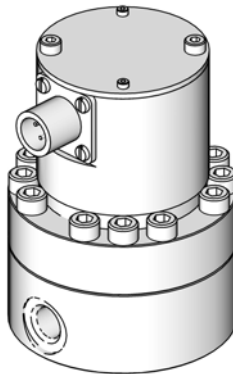

TI11579a



 Intertek
 3151640
 Class I, Div 1, Group D,
 T3 (Ta = 0° - 60°C)

 **II 1 G**
 Ex ia IIA T3
 0°C<Ta<60°C Ga
 ITS12ATEX27565X

 **0359**

Intrinsically Safe for Hazardous Locations (Class I; Division 1; Group D) when used with an approved barrier only.

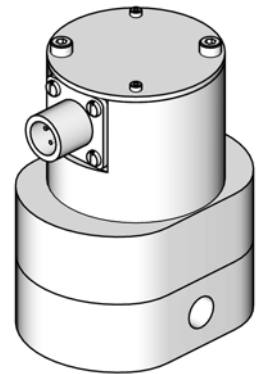
S3000 Solvent Meter



TI14674b

G250 and G250HR

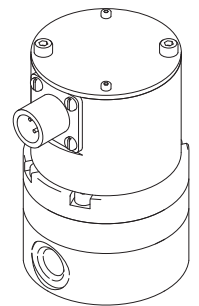

TI13038a

Contents

Meter Models	3	Maintenance	12
Low Pressure Fluid Meters	3	Residue Build-up on the Meter Gears	12
High Pressure Fluid Meters	3	Flushing	12
High Pressure Solvent Meter	3	Cleaning or Servicing the Meter Chamber	13
Meter Kits	3	Replacing the Electronic Sensor	13
G3000 Fluid Meter Kits	3	Cleaning or Servicing the Solvent Meter	14
Solvent Meter Kit	3	Parts	15
Warnings	4	Flow Meter Kits, for ProMix	
Installation	7	2KS Wall Fluid Panel	15
Dust and Foreign Matter	7	Bare Meter Assemblies	16
Installing the Flow Meter	7	Solvent Meter Assembly	18
Intrinsically Safe Installation Requirements	8	Dimensions	20
Grounding	9	Technical Data	22
Meter Cables and Adaptor	9	Pressure Drop Curve	23
Operation	10	Graco Standard Warranty	24
Pressure Relief Procedure	10	Graco Information	24
Flow Meter Function	10		
Recommended Usage	10		
Flow Volume Range	10		
Checking the Meter Accuracy	10		
Troubleshooting	11		

Meter Models

Low Pressure Fluid Meters

300 psi (2.1 MPa, 21 bar) Maximum Fluid Working Pressure

Meter Part No.	Series	Model	Flow Range
249426	B	G250	0.02 to 1.0 gpm (75 to 3800 cc/min)
249427	B	G250HR	0.01 to 0.5 gpm (38 to 1900 cc/min)

High Pressure Fluid Meters

4000 psi (28 MPa, 280 bar) Maximum Fluid Working Pressure

Meter Part No.	Series	Model	Flow Range
289813	B	G3000	0.02 to 1.0 gpm (75 to 3800 cc/min)
289814	B	G3000HR	0.01 to 0.5 gpm (38 to 1900 cc/min)
26A119	A	G3000A	0.02 to 1.0 gpm (75 to 3800 cc/min)

High Pressure Solvent Meter

3000 psi (21 MPa, 210 bar) Maximum Fluid Working Pressure

Meter Part No.	Series	Model	Flow Range
258718	B	S3000	0.01 to 0.42 gpm (38 to 1600 cc/min)

Meter Kits

G3000 Fluid Meter Kits

For use with ProMix 2KS Wall Fluid Panel. Kits include meter, cable, fluid tube, check valve, mounting bracket and hardware.

Kit Part No.	Meter
15V804	Part No. 289813 G3000 Meter
15V827	Part No. 289814 G3000HR Meter
826216	Part No. 26A119 G3000A Meter

Solvent Meter Kit



For use with ProMix 2KS Wall Fluid Panel. Kit includes meter, cable, fluid hose, check valve, fittings, mounting bracket and hardware.

Kit Part No.	Meter
280555	Part No. 258718 S3000 Solvent Meter

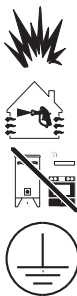

Warnings

The following warnings are for the setup, use, grounding, maintenance, and repair of this equipment. The exclamation point symbol alerts you to a general warning and the hazard symbols refer to procedure-specific risks. When these symbols appear in the body of this manual, refer back to these Warnings. Product-specific hazard symbols and warnings not covered in this section may appear throughout the body of this manual where applicable.



WARNING

	<p>FIRE AND EXPLOSION HAZARD</p> <p>Flammable fumes, such as solvent and paint fumes, in work area can ignite or explode. To help prevent fire and explosion:</p> <ul style="list-style-type: none"> • Use equipment only in well ventilated area. • Eliminate all ignition sources; such as pilot lights, cigarettes, portable electric lamps, and plastic drop cloths (potential static arc). • Keep work area free of debris, including solvent, rags and gasoline. • Do not plug or unplug power cords, or turn power or light switches on or off when flammable fumes are present. • Ground all equipment in the work area. See Grounding instructions. • Use only grounded hoses. • Hold gun firmly to side of grounded pail when triggering into pail. Do not use pail liners unless they are antistatic or conductive. • Stop operation immediately if static sparking occurs or you feel a shock. Do not use equipment until you identify and correct the problem. • Keep a working fire extinguisher in the work area.
	<p>INTRINSIC SAFETY</p> <p>Intrinsically safe equipment that is installed improperly or connected to non-intrinsically safe equipment will create a hazardous condition and can cause fire, explosion, or electric shock. Follow local regulations and the following safety requirements.</p> <ul style="list-style-type: none"> • Be sure your installation complies with national, state, and local codes for the installation of electrical apparatus in a Class I, Group D, Division 1 Hazardous Location, including all of the local safety fire codes, NFPA 33, NEC 500 and 516, and OSHA 1910.107. • Equipment that comes in contact with the safety barrier's intrinsically safe terminals must be rated for Intrinsic Safety. This includes DC voltage meters, ohmmeters, cables, and connections. Remove the unit from the hazardous area when troubleshooting. • If a printer, computer, or other electrical component is connected, it must be used in conjunction with a safety barrier. • Without the safety barrier, the equipment is no longer intrinsically safe and must not be operated in hazardous locations, as defined in article 500 of the National Electrical Code (USA) or your local electrical code. • Do not install equipment approved only for a non-hazardous location in a hazardous area. See the ID label for the intrinsic safety rating for the flow meter sensor. • Ground the intrinsically safe power supply. A voltage limiting safety barrier must be properly grounded to be effective. For proper grounding, use the ground wire provided (or a 12 gauge minimum ground wire), and the barrier's ground must be within 1 ohm of true earth ground. • Do not operate the safety barrier module with the cover removed. • Never use the flow meter with an electrostatic gun isolation stand.

! WARNING

	<p>SPECIAL CONDITIONS FOR SAFE USE</p> <p>Equipment must comply with the following conditions to avoid a hazardous condition which can cause fire, explosion, or electric shock:</p> <ul style="list-style-type: none"> • Sensor housing is of aluminum construction. Precautions must be taken to avoid impacts or contact with moving parts.
	<p>SKIN INJECTION HAZARD</p> <p>High-pressure fluid from gun, hose leaks, or ruptured components will pierce skin. This may look like just a cut, but it is a serious injury that can result in amputation. Get immediate surgical treatment.</p> <ul style="list-style-type: none"> • Do not spray without tip guard and trigger guard installed. • Engage trigger lock when not spraying. • Do not point gun at anyone or at any part of the body. • Do not put your hand over the spray tip. • Do not stop or deflect leaks with your hand, body, glove, or rag. • Follow the Pressure Relief Procedure when you stop spraying and before cleaning, checking, or servicing equipment. • Tighten all fluid connections before operating the equipment. • Check hoses and couplings daily. Replace worn or damaged parts immediately.
	<p>PRESSURIZED EQUIPMENT HAZARD</p> <p>Fluid from the equipment, leaks, or ruptured components can splash in the eyes or on skin and cause serious injury.</p> <ul style="list-style-type: none"> • Follow the Pressure Relief Procedure when you stop spraying/dispensing and before cleaning, checking, or servicing equipment. • Tighten all fluid connections before operating the equipment. • Check hoses, tubes, and couplings daily. Replace worn or damaged parts immediately.

! WARNING

	<p>EQUIPMENT MISUSE HAZARD</p> <p>Misuse can cause death or serious injury.</p> <ul style="list-style-type: none"> • Do not operate the unit when fatigued or under the influence of drugs or alcohol. • Do not exceed the maximum working pressure or temperature rating of the lowest rated system component. See Technical Data in all equipment manuals. • Use fluids and solvents that are compatible with equipment wetted parts. See Technical Data in all equipment manuals. Read fluid and solvent manufacturer’s warnings. For complete information about your material, request MSDS from distributor or retailer. • Do not leave the work area while equipment is energized or under pressure. • Turn off all equipment and follow the Pressure Relief Procedure when equipment is not in use. • Check equipment daily. Repair or replace worn or damaged parts immediately with genuine manufacturer’s replacement parts only. • Do not alter or modify equipment. Alterations or modifications may void agency approvals and create safety hazards. • Make sure all equipment is rated and approved for the environment in which you are using it. • Use equipment only for its intended purpose. Call your distributor for information. • Route hoses and cables away from traffic areas, sharp edges, moving parts, and hot surfaces. • Do not kink or over bend hoses or use hoses to pull equipment. • Keep children and animals away from work area. • Comply with all applicable safety regulations.
	<p>TOXIC FLUID OR FUMES HAZARD</p> <p>Toxic fluids or fumes can cause serious injury or death if splashed in the eyes or on skin, inhaled, or swallowed.</p> <ul style="list-style-type: none"> • Read MSDSs to know the specific hazards of the fluids you are using. • Store hazardous fluid in approved containers, and dispose of it according to applicable guidelines. • Always wear chemically impermeable gloves when spraying, dispensing, or cleaning equipment.
	<p>PERSONAL PROTECTIVE EQUIPMENT</p> <p>Wear appropriate protective equipment when in the work area to help prevent serious injury, including eye injury, hearing loss, inhalation of toxic fumes, and burns. This protective equipment includes but is not limited to:</p> <ul style="list-style-type: none"> • Protective eyewear, and hearing protection. • Respirators, protective clothing, and gloves as recommended by the fluid and solvent manufacturer.

Installation

<p>Improper wiring can cause fire and explosion, electric shock, or other serious injury.</p> <ul style="list-style-type: none"> • Disconnect power source before installing. • All electrical equipment must only be installed by a qualified electrician. • Understand and follow your local code and safety regulations for hazardous location wiring of intrinsically safe circuits. 						

Installing the Flow Meter

NOTE: You must assemble the meter sensor to the meter body before connecting the cable to the sensor for the meter to function properly.

- Flow volume can only be measured at the location where the flow meter is installed.
- The Fluid Flow Meters are intrinsically safe for Hazardous (Classified) Locations, when installed with an intrinsically safe power device and wiring:
 Class I, Div I, Group D, T3 (US and Canada)
 Class I, Zone I Group IIA T3 (ATEX only)
 TA = 0°C to 60°C

Refer to ANSI standards ISA-RP12.6, NEC Article 504 and the Canadian Electrical Code Appendix F.

Dust and Foreign Matter

Avoid having dust or foreign matter enter the flow meter by taking the following precautions:

- Thoroughly flush the fluid supply lines before installing the flow meter.
- When installing fittings, make sure that no sealing tape overlaps into the inside of the pipe.
- Install a 100 mesh fluid filter upstream of the flow meter.

- Do not use more than 200 ft. (61 m) of cable.
- Refer to FIG. 1 to locate and install the flow meter, connectors, and fluid shutoff valves. Install a check valve to prevent backflow. The arrows on the flow meter and check valve show the direction of fluid flow.
- The shutoff valves allow you to isolate the meter for service.
- Refer to **Dimensions** on page 20 and **Technical Data** on page 22 for dimension, inlet/outlet size, temperature and other specifications.

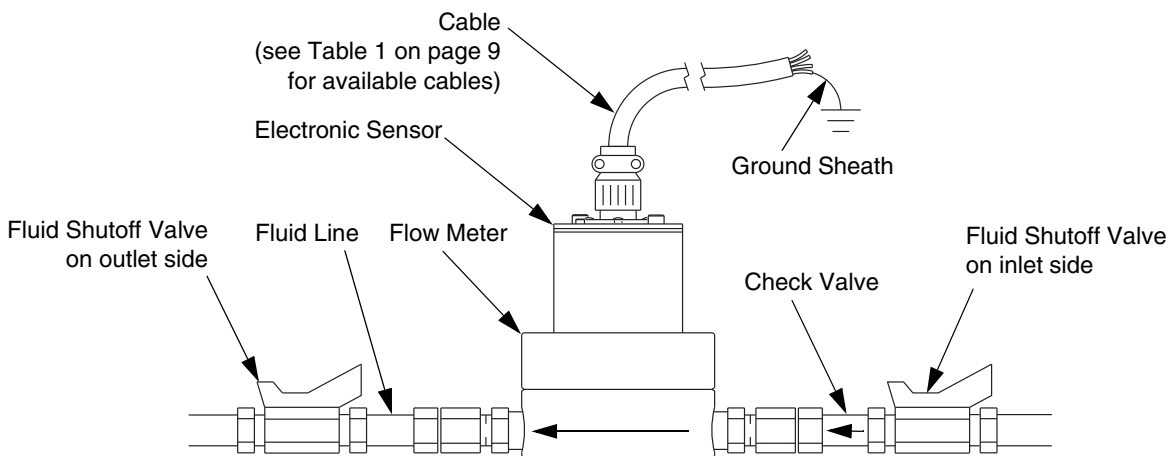

7379A

FIG. 1: Typical Installation

Intrinsically Safe Installation Requirements

See FIG. 2.

1. The non-intrinsically safe terminals must not be connected to any device which uses or generates more than 250 Vrms or dc unless it has been determined that the voltage has been adequately isolated.
2. The installation must meet the requirements of the National Electric Code, Canadian Electrical Code Part I, NFPA 70, Article 504 Resp., Article 505 and ANSI/ISA 12.06.01.
3. Multiple earthing of components is allowed only if high integrity equipotential system is realized between the points of bonding.
4. Do not operate system with safety barrier cover removed.

5. For ATEX, install per EN 60079-14 and applicable local and national codes.
6. Cable used to connect sensor and safety barrier must take capacitance and inductance into account. The maximum capacitance of the barrier is to be greater than the cable capacitance plus the sensor capacitance (Ci). The maximum inductance of the barrier is to be greater than the cable inductance plus the sensor inductance (Li).

Find cable capacitance and inductance by:

- a. Using the most exacting electrical parameters provided by the cable manufacturer.
 - b. Using the electrical parameters determined by measurement of a sample.
7. Product meets 500 Vac isolation test between the intrinsically safe circuits and earth ground.

ATEX CERTIFICATE #ITS12ATEX27565X SYSTEM ASSEMBLY CERTIFICATE

NON-HAZARDOUS LOCATION ONLY

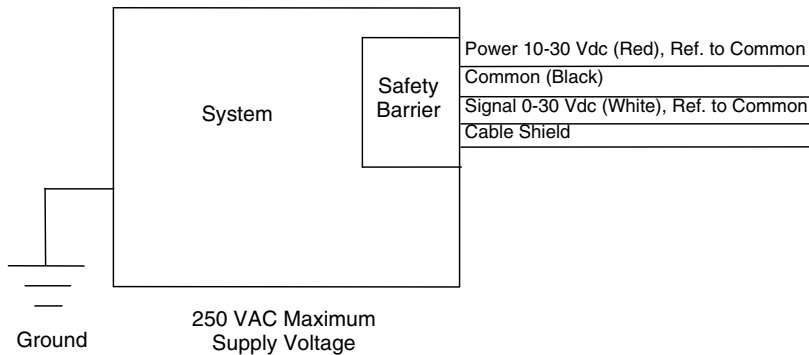

NOTE: See **Intrinsically Safe Installation Requirements** above.

WARNING: Substitution of components may impair intrinsic safety. For installation, maintenance or operation instructions, see instruction manual.

ADVERTISSEMENT: La substitution de composants peut compromettre la sécurité intrinsèque.

HAZARDOUS (CLASSIFIED) LOCATION

CLASS I, DIV I, GROUP D, T3 (US AND CANADA)
CLASS I, ZONE I GROUP IIA T3 (ATEX ONLY)
TA = 0°C TO 60°C

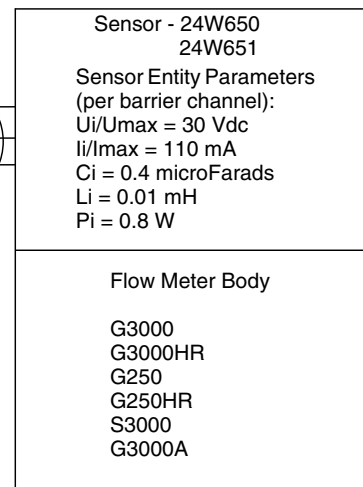

Ground
(Grounded thru meter mounting bracket to system ground.)

24M600
Control Drawing

FIG. 2. Intrinsically Safe Installation

Grounding

<p>The equipment must be grounded to reduce the risk of static sparking and electric shock. Electric or static sparking can cause fumes to ignite or explode. Improper grounding can cause electric shock. Grounding provides an escape wire for the electric current.</p>						

1. Ground the flow meter by connecting a grounded cable to the meter housing or sensor.

Have a qualified electrician check the electrical grounding continuity between the flow meter sensor and a true earth ground; remove the cable connector from the sensor and measure the resistance from the cable connector Pin 2 to true earth ground. Refer to FIG. 3.

If the resistance is greater than 25 ohms, check the cable ground connection. Refer to FIG. 3. Reconnect the ground sheath or replace the cable. Do not operate the system until the problem is corrected.

2. Always ground the meter, using one of the following options:

- a. Mount the meter to a grounded conductive surface, or
 - b. Connect the conductive fluid hose to the meter inlet and outlet, or
 - c. Connect a ground wire to the meter's M6 mounting holes.
3. Never use the flow meter with an electrostatic gun isolation stand.

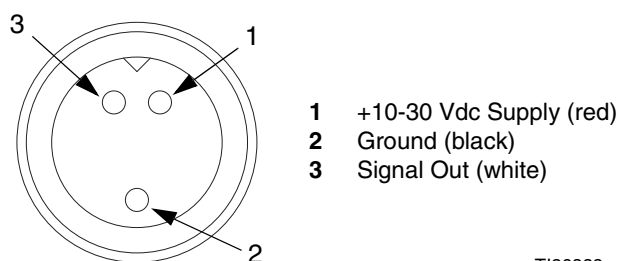

T126838a

FIG. 3

Meter Cables and Adaptor

See Table 1 for available meter cables or the adaptor for use with cables with a black plastic connector and a replacement sensor.

Table 1: Meter Cables

Cable Part No.	Length	Ferrite	Platform
17C743	5 ft (1.52 m)		Various
17C910	42 in. (1029 mm)	15D906	ProMix 2KS
17C887	6 ft (1.83 m)		Various
17C888	50 ft (15.25 m)		Various
17C889	150 ft (45.75 m)		Various
24Y434	Adaptor - Not included with cables (see note)		
<p>NOTE: These cables have a metal connector, which will only mate with a sensor that also has a metal connector. Adaptor 24Y434 is required to connect an existing cable with a plastic connector to a replacement sensor, which has a metal connector.</p> <p>Adaptor 24Y434 purchased separately.</p>			

Operation

Pressure Relief Procedure



This equipment stays pressurized until pressure is manually relieved. To help prevent serious injury from pressurized fluid, such as skin injection, splashing fluid and moving parts, follow the Pressure Relief Procedure when you stop spraying and before cleaning, checking, or servicing the equipment.

1. Shut off the fluid supply to the meter.
2. Shut off all electrical power to the fluid system.
3. Follow the **Pressure Relief Procedure** for your fluid system dispensing device.

Flow Meter Function

This is a positive displacement, gear flow meter. The gear flow meter is highly accurate, even with low flow rates. The fluid flowing through the meter rotates the gears. The gear tooth is picked up by a sensor device, which produces an impulse for every gear tooth passing by.

Recommended Usage



Do not exceed the maximum working pressure of your meter or any component or accessory in your system.

- See the **Technical Data** on page 22 for fluid and ambient temperature limits.
- Only use the flow meter with fluids that are compatible with the “Wetted Parts” listed in the **Technical Data**.

Flow Volume Range

The G3000v G3000A, and G250 meters flow volume range is 0.02-1.0 gal./min. (75-3800 cc/min.).

The G3000HR and G250HR meters flow volume range is 0.01-0.5 gal./min. (38-1900 cc/min.).

The S3000 solvent meter flow volume range is 0.01-0.42 gpm (38-1600 cc/min).

NOTICE
The flow meter gears and bearings can be damaged if they rotate at excessive speeds. To avoid high speed rotation, open the fluid valve gradually. Do not over-speed the meter with air or fluid. Do not use compressed air to rotate flow meter gears. Do not exceed the meter’s maximum flow rate.

Checking the Meter Accuracy

1. To check the accuracy of the meter, turn your gun fan and atomizing air off, then trigger the fluid into a graduated cylinder; dispense at least 500 cc of fluid.
2. Measure the volume of fluid in the beaker in cubic-centimeters (cc) and read the volume on the flow meter monitor.

G3000, G3000A, and G250: If the flow meter scale factor is not between 0.112-0.140 cc/pulse, follow the cleaning procedure on page 13, then recalibrate the flow meter.

G3000HR and G250HR: If the flow meter scale factor is not between 0.05-0.07 cc/pulse, follow the cleaning procedure on page 13, then recalibrate the flow meter.

S3000: If the solvent meter scale factor is not between 0.019-0.022 cc/pulse, follow the cleaning procedure on page 13, then recalibrate the flow meter.

Troubleshooting





Before servicing this equipment always make sure to **relieve the pressure**.

NOTE: The sensor is not a serviceable part. Replace it if it is malfunctioning.

Problem	Cause	Solution
No flow volume displayed at monitoring unit.	Flow volume is too low to measure.	Increase flow volume.
	Fluid is not flowing.	Repair.
	Damaged cable.	Replace cable.
	Improper input voltage to sensor.	Make sure input voltage is 10-30 Vdc.
	Damaged sensor.	Replace sensor if it is malfunctioning.
Fluid is not flowing.	Clogs in fluid line or in meter.	Clean fluid line and/or meter; see Maintenance on page 12.
	Gears worn or damaged.	Repair meter; see Maintenance on page 12.

Maintenance

						
<p>Improper wiring can cause fire and explosion, electric shock, or other serious injury.</p> <ul style="list-style-type: none"> • Disconnect power source before installing. • All electrical equipment must only be installed by a qualified electrician. • Understand and follow your local code and safety regulations for hazardous location wiring of intrinsically safe circuits. 						

NOTICE
<p>Do not immerse the meter in solvent with the electronic sensor installed. Solvent could damage the electrical components.</p> <p>Air purge is not recommended for any gear-type flow meter. Air purges do not provide the lubrication the meter gears require.</p>

Residue Build-up on the Meter Gears

Residue build-up may cause the meter gears to bind or stop rotating, which decreases the meter accuracy and makes meter recalibration necessary. As more build-up occurs, recalibration is required more often.

The frequency that your meter requires cleaning depends on the type of fluid being used. Excessive residue build-up usually means that you are using improper cleaning solvents and/or cleaning sequences or processes.

- Check the meter routinely to develop the correct cleaning schedule.
- Use the proper cleaning solvent for the fluid being metered.

Flushing





Flush the fluid supply line and meter fluid reservoir daily with a compatible solvent as instructed below.

1. Follow the **Pressure Relief Procedure**, on page 10.
2. Connect the fluid line to the solvent supply unit.
3. Flush the meter until it is clean.
4. Follow the **Pressure Relief Procedure**, then disconnect the fluid line from the solvent supply unit.
5. Reconnect the fluid line to the fluid (paint) supply.
6. Turn on the fluid supply.
7. Operate until the meter and fluid line are free of solvent.

Cleaning or Servicing the Meter Chamber

NOTICE

Clean and service the meter at a clean workbench.
Use only lint-free cloth on parts.

						
<p>Installing and servicing this equipment requires access to parts that may cause electric shock or other serious injury if the work is not performed properly. Do not install or service this equipment unless you are trained and qualified.</p> <p>Use only genuine Graco replacement parts. Substitution of components may impair intrinsic safety. This could result in a failure which causes serious injury and/or substantial property damage.</p>						

						
---	---	---	---	---	--	--

1. Follow the **Pressure Relief Procedure**, on page 10. Then close the fluid shut-off valve on each side of the meter.
2. Disconnect the cable from the electronic sensor device.
3. Disconnect both fluid line fittings and remove the meter from the fluid line.
4. Loosen the two screws and remove the electronic sensor device from the flow meter upper housing. See the **Parts** drawings, pages 16-18.
5. Loosen the screws. Keep a few threads of two opposing bolts engaged to minimize the torque stress on the shafts when you separate the meter housings.
6. Hold onto the upper housing and gently tap the opposing bolts to separate the lower housing.

NOTICE

To avoid damaging the shafts, keep the housings parallel to each other when separating them; do not rock the housings from side to side. Do not use chisels or screwdrivers to split and pry apart the housings.

7. Remove and inspect the gears and shafts. Clean the meter parts with solvent.
8. Reassemble the gears and shafts into the lower housing in the position they were removed from. Check the gears for free and easy rotation.
9. Make sure the two locating pins are in place.
10. Assemble the two meter housings, making sure to keep them parallel to each other.
11. Install the screws. Tighten them oppositely and evenly. Tighten to 12 ft-lb (16 N•m) for 289813, 289814, and 26A119. Tighten to 42 in-lb (4.7 N•m) for 249426 and 249427. Do not over-tighten.
12. After re-assembling the meter, test the gear rotation by applying a brief air blast to the meter inlet. You should clearly hear the gears spin.
13. Set the electronic sensor on the upper housing and tighten the two screws hand-tight, about 27-57 in-lb (3.1-6.4 N•m). Do not over-tighten.
14. Attach fluid lines and sensor cable.
15. Open fluid shut-off valves.

Replacing the Electronic Sensor

1. Follow the **Pressure Relief Procedure**, on page 10. Then close the fluid shut-off valve on each side of the meter.
2. Disconnect the cable from the electronic sensor device.
3. Loosen the two screws and remove the electronic sensor device from the flow meter upper housing. See the **Parts** drawings, pages 16-18.
4. Set the electronic sensor on the upper housing and tighten the two screws hand-tight, about 27-57 in-lb (3.1-6.4 N•m). Do not over-tighten.
5. Attach sensor cable.

Cleaning or Servicing the Solvent Meter

NOTICE

Clean and service the meter at a clean workbench. Use only lint-free cloth on parts.

--	--	--	--	--	--

Installing and servicing this equipment requires access to parts that may cause electric shock or other serious injury if the work is not performed properly. Do not install or service this equipment unless you are trained and qualified.

Use only genuine Graco replacement parts. Substitution of components may impair intrinsic safety. This could result in a failure which causes serious injury and/or substantial property damage.

--	--	--	--	--	--	--

1. Follow the **Pressure Relief Procedure**, on page 10. Then close the fluid shut-off valve on each side of the meter.
2. Disconnect the cable from the electronic sensor device.
3. Disconnect both fluid line fittings and remove the meter from the fluid line.
4. Loosen the two screws and remove the electronic sensor device from the flow meter upper housing. See the **Parts** drawing, page 18.
5. Unscrew the 8 screws (3a) from the base (3b) of the meter.
6. Carefully remove the cover (3f). Turn it over and remove the shims (3c).

NOTE: See FIG. 4. Two shim configurations are used. Some meters use one 0.1 mm shim (3c) above each gear (3d) and one below. Other meters stack three shims (.02 and .05 mm, for a total shim height of .09 mm) above and below each gear. When replacing shims, always maintain the configuration used on your meter.

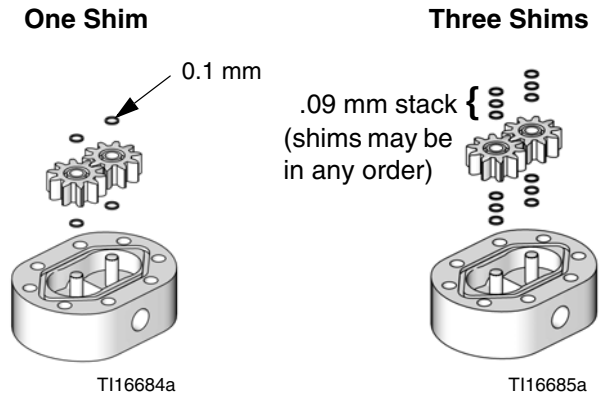

FIG. 4. Shim Configurations

7. Remove the o-ring (3e). Carefully remove the gear/bearing assemblies (3d). Remove the shims (3c).

NOTE: Do not remove the gear shafts (S) or the gear bearings (B).

8. Clean the meter parts with solvent. Do not use aggressive cleaning agents. Ultrasonic cleaning is recommended for the gear/bearing assemblies. Dry all parts thoroughly after cleaning.
9. Place the bottom shims (3c) on the shafts (S). Maintain the configuration used on your meter.
10. Install the gear/bearing assemblies (3d) on the shafts. Install the top shims (3c). Maintain the configuration used on your meter.
11. Insert the o-ring (3e) in the groove of the cover (3f). Carefully mount the cover on the base (3b).
12. Install the screws (3a). Tighten them oppositely and evenly, to 11 ft-lb (15 N•m). Do not over-tighten.
13. After tightening all screws, insert a plastic pick through the meter inlet or outlet and check that the gears can turn freely.
14. Set the electronic sensor on the cover and tighten the two screws hand-tight, about 27-57 in-lb (3.1-6.4 N•m). Do not over-tighten.

Parts

Flow Meter Kits, for ProMix 2KS Wall Fluid Panel

15V804 G3000 Meter Kit
 826212 G3000A Meter Kit
 15V827 G3000HR Meter Kit

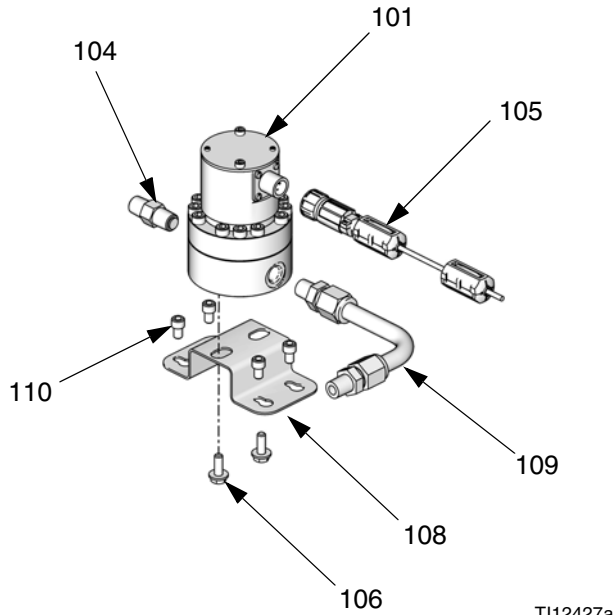

280555 S3000 Solvent Meter Kit

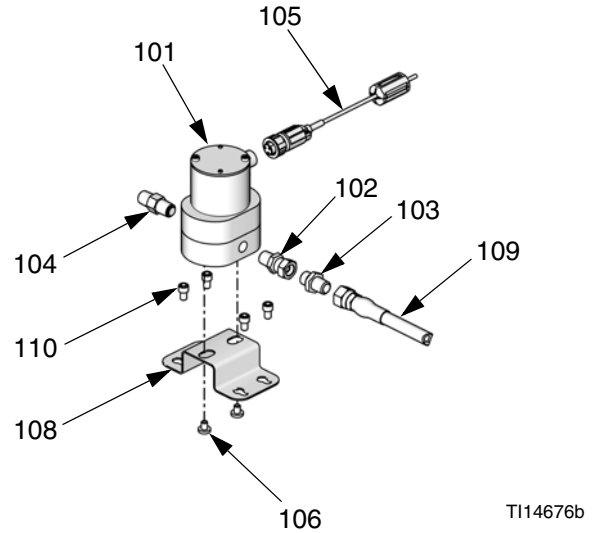

Ref. No.	Part No.	Description	Qty
101	289813	METER, gear, G3000; used on 15V804; see page 16	1
	26A119	METER, gear, G3000A; used on 826212; see page 16	1
	289814	METER, gear, G3000HR; used on 15V827; see page 16	1
104	501867	VALVE, check	1
	24T894	VALVE, check (826212)	1
105	17C910	HARNESS, cable, with connector	1
106	114182	SCREW, machine, hex flange hd; M6 x 10; 16 mm	2
108	15U749	BRACKET, mounting	1
109	15U750	TUBE, assembly; sst; 1/2 in. (13 mm) OD tube x 1/4 npt	1
	25A517	HOSE (826212)	1
110	C19798	SCREW, cap, socket-hd; 1/4-20 x 3/8 in. (10 mm)	4
111	121907	FITTING, NIPPLE, HEX 1/4 npt 316 sst (826212)	2

Ref. No.	Part No.	Description	Qty
101	258718	METER, gear, S3000; used on 280555; see page 18	1
102	114339	UNION, swivel; 1/4 npt(m) x 1/4 npsm(f)	1
103	166846	ADAPTER; 1/4 npt x 1/4 npsm (mbe)	1
104	501867	VALVE, check	1
105	17C910	HARNESS, cable, with connector	1
106	551295	SCREW, machine, pan hd; M6 x 1; 8 mm	2
108	15U749	BRACKET, mounting	1
109	512616	HOSE; ptfе; 1/4 in. (13 mm) ID; 1/4 npsm(f); 1.5 ft (0.46 m)	1
110	C19798	SCREW, cap, socket-hd; 1/4-20 x 3/8 in. (10 mm)	4

Bare Meter Assemblies

289813 G3000 Meter
 26A119 G3000A Meter
 289814 G3000HR Meter

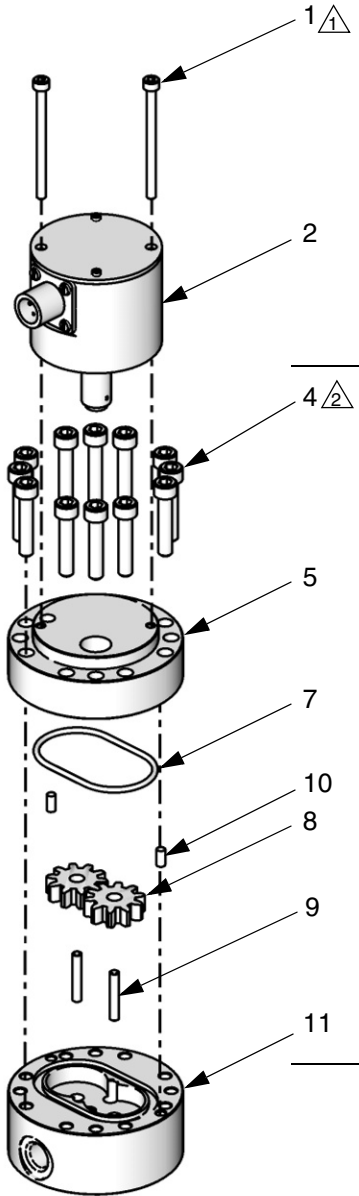

Item 3, Gear Meter Assembly includes items 4-11

T111580a

1 Torque to 27-57 in-lb (3.1-6.4 N•m).

2 Torque to 12 ft-lb (16 N•m).

Ref. No.	Part No.	Description	Qty
1	114100	SCREW, socket-hd; M4 x 55 mm long	2
2	24W651	ELECTRONIC SENSOR**	1
3	239719	GEAR METER ASSEMBLY; includes items 4-11; used on 289813	1
	26A118	GEAR METER ASSEMBLY; includes items 4-11; used on 26A119	1
	244291	GEAR METER ASSEMBLY; includes items 4-11; used on 289814	1
4	110580	• SCREW	12
5	*	• HOUSING, upper	1
7	110588	• O-RING; ptfе	1
8	239718	• GEAR; used on 289813	2
	26A120	• GEAR; used on 26A119	2
	244290	• GEAR; used on 289814	2
9	192383	• SHAFT, gear; used on 289813	2
	17L420	• SHAFT, gear; used on 26A119	2
	197142	• SHAFT, gear; used on 289814	2
10	192387	• PIN, locating	2
11	*	• HOUSING, lower	1

* Not a replacement part. Order item 3, gear meter assembly.

** Replacing this part will also require adaptor 24Y434 or a replacement cable if the existing cable has a black plastic coupler.

249426 G250 Meter

249427 G250HR Meter

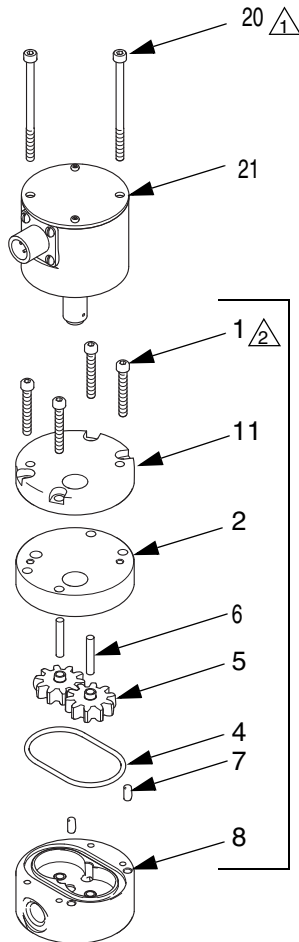

Item 22, Gear Meter Assembly includes items 1-11

Ref. No.	Part No.	Description	Qty
1	111308	SCREW, cap, socket-hd	4
2	*	HOUSING, upper	1
4	110588	O-RING; ptfе	1
5	239718	GEAR; used on 249426	2
	244290	GEAR; used on 249427	2
6	192383	SHAFT, gear; used on 249426	2
	197142	SHAFT, gear; used on 249427	2
7	192387	PIN, locating	2
8	*	HOUSING, lower	1
11	15F866	SPACER	1
20	119839	SCREW, cap, socket-hd; M4x65	2
21	24W651	ELECTRONIC SENSOR**	1
22	249428	GEAR METER ASSEMBLY; includes items 1-11; used on 249426	1
	249429	GEAR METER ASSEMBLY; includes items 1-11; used on 249427	1

* Not a replacement part. Order item 22, gear meter assembly.

** Replacing this part will also require adaptor 24Y434 or a replacement cable if the existing cable has a black plastic coupler.

T113039a

Torque to 27-57 in-lb (3.1-6.4 N•m).

Torque to 42 in-lb (4.7 N•m).

Solvent Meter Assembly

258718 S3000 Meter

△1 Torque to 27-57 in-lb (3.1-6.4 N•m).

△2 Torque to 11 ft-lb (15 N•m).

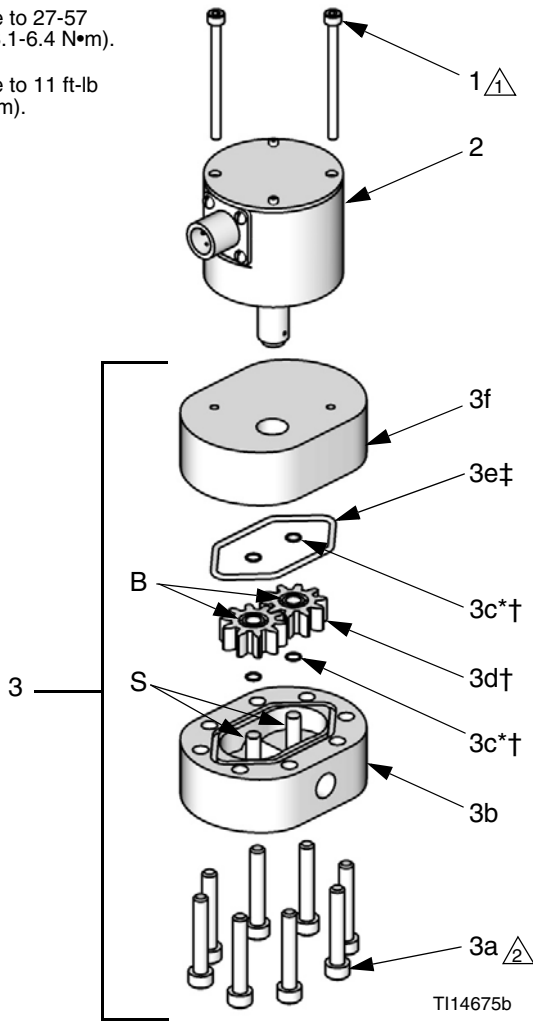

Ref. No.	Part No.	Description	Qty
1	114100	SCREW, socket-hd; M4 x 55 mm long	2
2	24W650	ELECTRONIC SENSOR**	1
3	24G951	GEAR METER ASSEMBLY; used on 258718; includes items 3a-3f	1
3a	---	• SCREW; M6 x 30	8
3b	---	• BASE	1
3c*†	---	• SHIM SET; see sizes below	4
3d†	---	• GEAR/BEARING ASSEMBLY	2
3e‡	---	• O-RING; ptfе	1
3f	---	• COVER	1

* Included in Shim Kit 24G735. Order separately. Kit includes 4 each of 0.1 mm and .05 mm sizes, and 8 of .02 mm size. Use sizes appropriate for your meter. Discard unused sizes. See page 14 for shim installation instructions.

** Replacing this part will also require adaptor 24Y434 or a replacement cable if the existing cable has a black plastic coupler.

† Included in Gear/Shim Kit 24G736. Order separately. Kit includes 2 gear/bearing assemblies with appropriate size shims.

‡ Included in O-Ring Kit 24G737. Order separately.

Detail of Three Shim Configuration

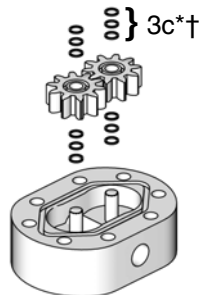

Dimensions

G3000, G3000A, and G3000HR

Mounting Holes (bottom)

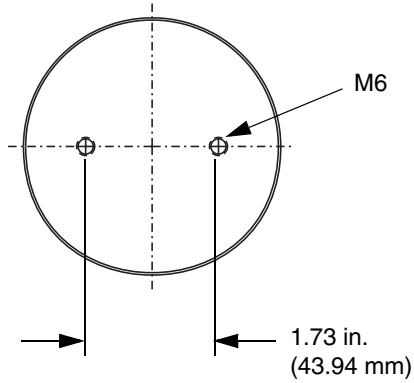

TI7382a

G250 and G250HR

Mounting Holes (bottom)

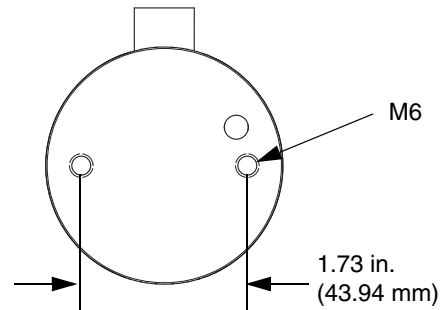

TI13043a

Part Nos. 289813, 289814, and 26A119

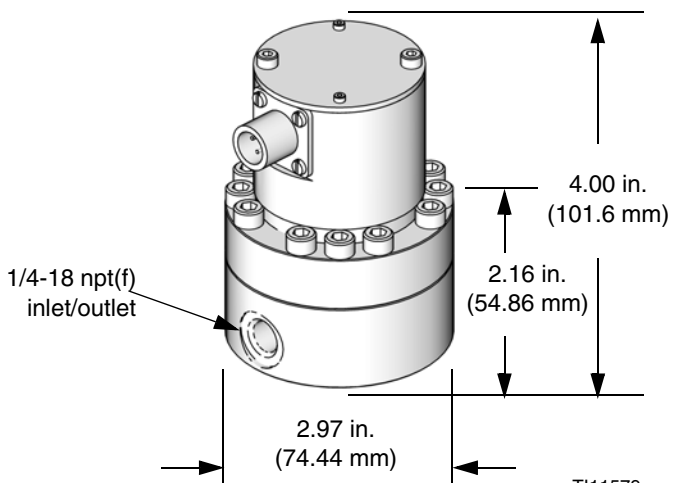

TI11579a

Part Nos. 249426 and 249427

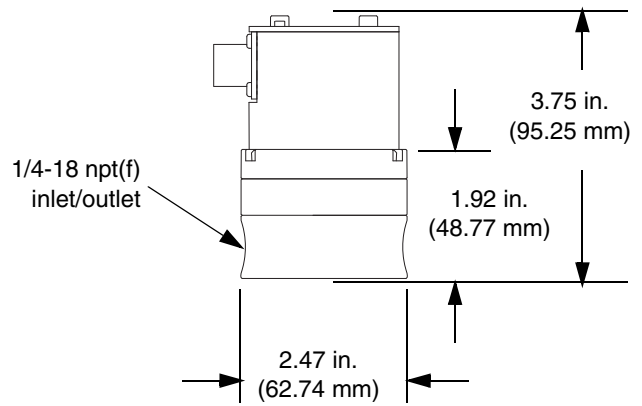

TI13042a

Solvent Meter

Part No. 258718

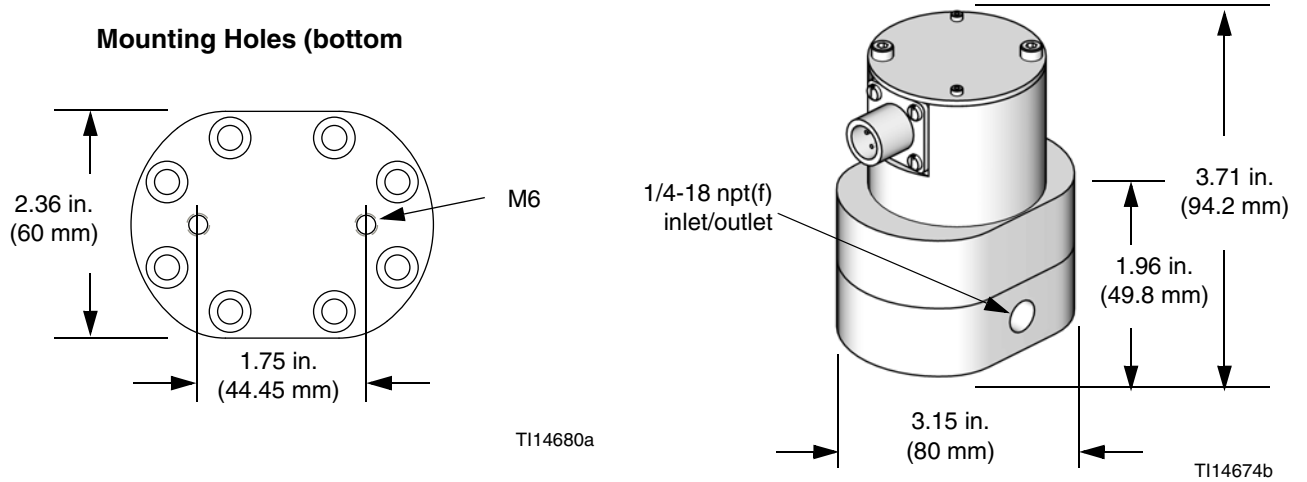

Kit Mounting Bracket

Part No. 15U749

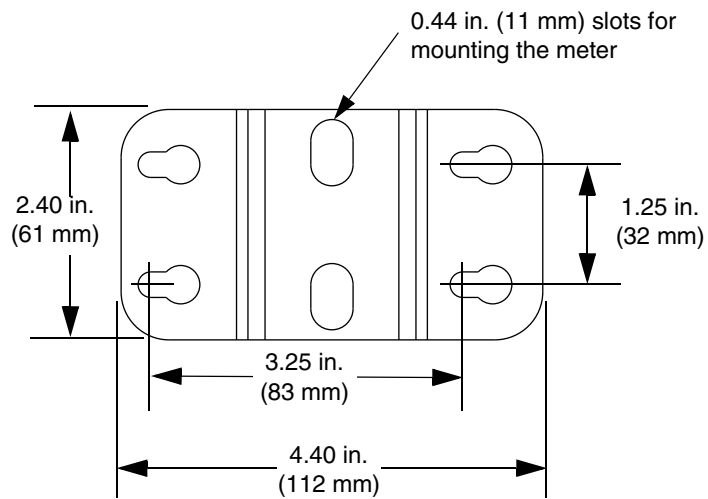

Technical Data

Volumetric Fluid Flow Meters		
	U.S.	Metric
Maximum Fluid Working Pressure		
G3000, G3000A, and G3000HR	4000 psi	28 MPa, 276 bar
S3000 Solvent Meter	3000 psi	21 MPa, 210 bar
G250 and G250HR	300 psi	2.1 MPa, 21 bar
Flow Range		
G3000, G3000A, and G250	0.02-1.0 gal/min	75-3800 cc/min
G3000HR and G250HR	0.01-0.5 gal/min	38-1900 cc/min
S3000 Solvent Meter	0.01-0.42 gal/min	38-1600 cc/min
Fluid Temperature Range		
	40-180°F	4-82°C
Maximum Ambient Temperature		
	140°F	60°C
Fluid Viscosity Range		
G3000, G3000A, and G3000HR	20-3000 cps (see Pressure Drop Curve on page 23)	
S3000 Solvent Meter	solvent and light viscosity clear fluids (20-50 cps)	
G250 and G250HR	20-3000 cps (see Pressure Drop Curve on page 23)	
Maximum Cable Length		
	200 ft	61 m
Flow Meter Inlet/Outlet		
	1/4 npt(f)	
Resolution		
G3000, G3000A, and G250	0.119 cc/pulse	
G3000HR and G250HR	0.061 cc/pulse	
S3000 Solvent Meter	0.021 cc/pulse	
Accuracy		
G3000, G3000A, G3000HR, G250, and G250HR	+/- 0.5% through communicated flow range for most commonly used coatings. Accuracy will diminish at low viscosities and low flow rates.	
S3000 Solvent Meter	+/- 2.5% through communicated flow range.	
Supply Voltage		
	10-30 Vdc	
Entity Parameters		
	V max = 30 V; I max = 15 mA; Ci = 0.4 microfarads; Li = .01 mH	
Approvals		
	See front cover	
Wetted Parts		
G3000 and G3000HR	303 Stainless Steel, Tungsten Carbide, PTFE	
G3000A	316 SST, 17-4 SST, PTFE	
S3000 Solvent Meter	303 Stainless Steel, PTFE	
G250 and G250HR	303 Stainless Steel, Tungsten Carbide, PTFE	
15V804, 15V827, and 280555 Meter Kits	303, 304, 17-4, and 17-7 Stainless Steel, PTFE	
Weight		
G3000, G3000A, and G3000HR	6 lb	2.7 kg
S3000 Solvent Meter	6 lb	2.7 kg
G250 and G250HR	2.6 lb	1.8 kg

Pressure Drop Curve

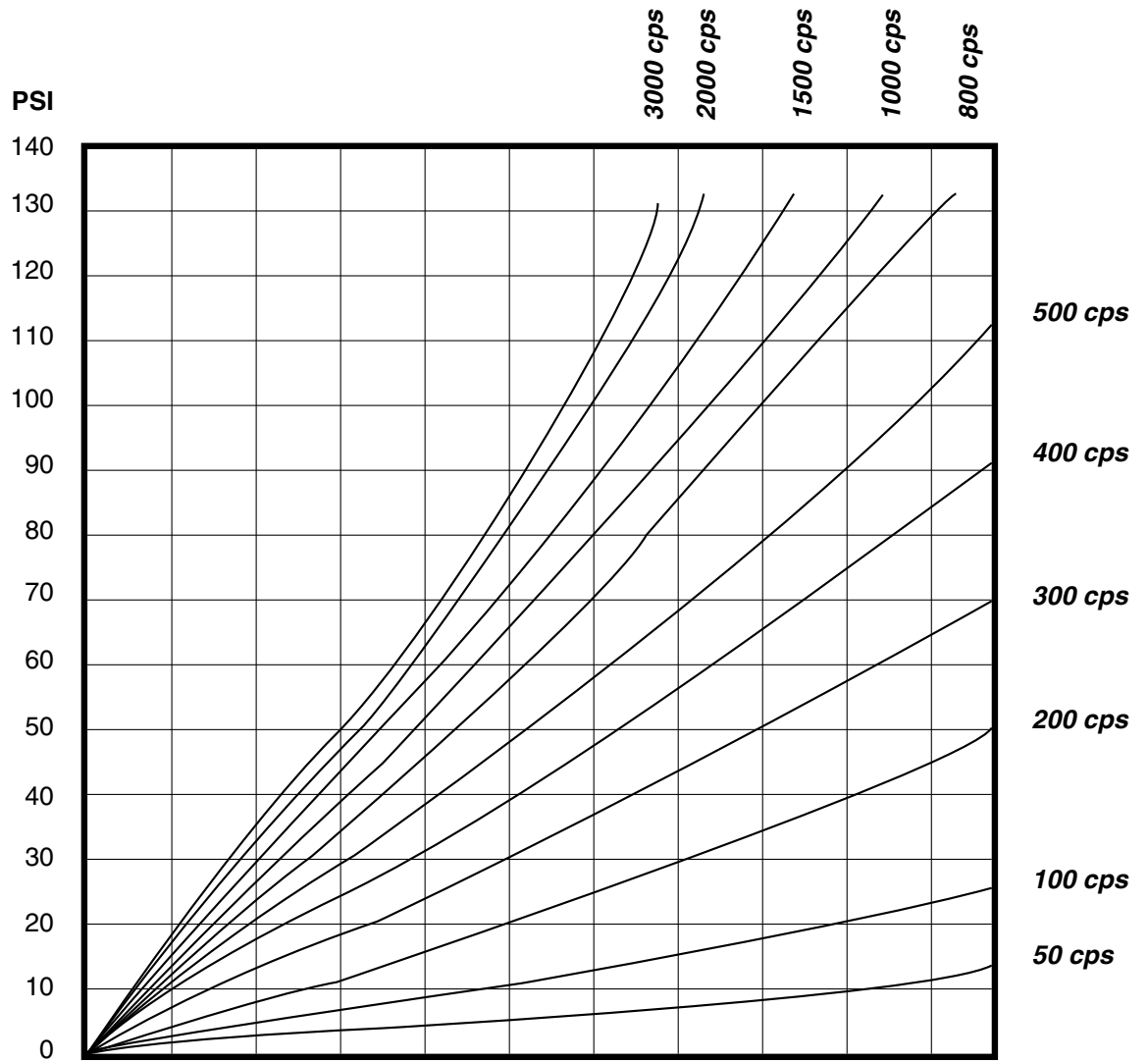

G3000/G3000A	0.0	0.1	0.2	0.3	0.4	0.5	0.6	0.7	0.8	0.9	1.0	1.1	gal/min
G250	0.0	0.05	0.10	0.15	0.20	0.25	0.30	0.35	0.40	0.45	0.50	0.55	gal/min
G3000HR/G250HR	0.0	0.025	0.05	0.065	0.076	0.083	0.10	0.13	0.16	0.19	0.22	0.25	gal/min

Graco Standard Warranty

Graco warrants all equipment referenced in this document which is manufactured by Graco and bearing its name to be free from defects in material and workmanship on the date of sale to the original purchaser for use. With the exception of any special, extended, or limited warranty published by Graco, Graco will, for a period of twelve months from the date of sale, repair or replace any part of the equipment determined by Graco to be defective. This warranty applies only when the equipment is installed, operated and maintained in accordance with Graco's written recommendations.

This warranty does not cover, and Graco shall not be liable for general wear and tear, or any malfunction, damage or wear caused by faulty installation, misapplication, abrasion, corrosion, inadequate or improper maintenance, negligence, accident, tampering, or substitution of non-Graco component parts. Nor shall Graco be liable for malfunction, damage or wear caused by the incompatibility of Graco equipment with structures, accessories, equipment or materials not supplied by Graco, or the improper design, manufacture, installation, operation or maintenance of structures, accessories, equipment or materials not supplied by Graco.

This warranty is conditioned upon the prepaid return of the equipment claimed to be defective to an authorized Graco distributor for verification of the claimed defect. If the claimed defect is verified, Graco will repair or replace free of charge any defective parts. The equipment will be returned to the original purchaser transportation prepaid. If inspection of the equipment does not disclose any defect in material or workmanship, repairs will be made at a reasonable charge, which charges may include the costs of parts, labor, and transportation.

THIS WARRANTY IS EXCLUSIVE, AND IS IN LIEU OF ANY OTHER WARRANTIES, EXPRESS OR IMPLIED, INCLUDING BUT NOT LIMITED TO WARRANTY OF MERCHANTABILITY OR WARRANTY OF FITNESS FOR A PARTICULAR PURPOSE.

Graco's sole obligation and buyer's sole remedy for any breach of warranty shall be as set forth above. The buyer agrees that no other remedy (including, but not limited to, incidental or consequential damages for lost profits, lost sales, injury to person or property, or any other incidental or consequential loss) shall be available. Any action for breach of warranty must be brought within two (2) years of the date of sale.

GRACO MAKES NO WARRANTY, AND DISCLAIMS ALL IMPLIED WARRANTIES OF MERCHANTABILITY AND FITNESS FOR A PARTICULAR PURPOSE, IN CONNECTION WITH ACCESSORIES, EQUIPMENT, MATERIALS OR COMPONENTS SOLD BUT NOT MANUFACTURED BY GRACO. These items sold, but not manufactured by Graco (such as electric motors, switches, hose, etc.), are subject to the warranty, if any, of their manufacturer. Graco will provide purchaser with reasonable assistance in making any claim for breach of these warranties.

In no event will Graco be liable for indirect, incidental, special or consequential damages resulting from Graco supplying equipment hereunder, or the furnishing, performance, or use of any products or other goods sold hereto, whether due to a breach of contract, breach of warranty, the negligence of Graco, or otherwise.

FOR GRACO CANADA CUSTOMERS

The Parties acknowledge that they have required that the present document, as well as all documents, notices and legal proceedings entered into, given or instituted pursuant hereto or relating directly or indirectly hereto, be drawn up in English. Les parties reconnaissent avoir convenu que la rédaction du présente document sera en Anglais, ainsi que tous documents, avis et procédures judiciaires exécutés, donnés ou intentés, à la suite de ou en rapport, directement ou indirectement, avec les procédures concernées.

Graco Information

For the latest information about Graco products, visit www.graco.com.

TO PLACE AN ORDER, contact your Graco distributor or call to identify the nearest distributor.

Phone: 612-623-6921 **or Toll Free:** 1-800-328-0211 **Fax:** 612-378-3505

All written and visual data contained in this document reflects the latest product information available at the time of publication. Graco reserves the right to make changes at any time without notice.

Original instructions. This manual contains English. MM 308778

Graco Headquarters: Minneapolis

International Offices: Belgium, China, Japan, Korea

GRACO INC. AND SUBSIDIARIES • P.O. BOX 1441 • MINNEAPOLIS MN 55440-1441 • USA
Copyright 1997, Graco Inc. All Graco manufacturing locations are registered to ISO 9001.

www.graco.com

Revision Y, August 2018