



# Throat Seal Upgrade Kits

406864D  
EN

To upgrade older 1000cc, 1500cc, and 2000cc High-Flo lowers that have torqueable throat packings and an open wet-cup to spring loaded throat packings and an open wet-cup.

**Kit 24F063 - For SST Lowers.**

**Kit 24F064 - For CST Lowers.**



**Important Safety Instructions**

Read all warnings and instructions in this manual and in your 4-Ball pump manual 3A0539. Save all instructions.

**NOTE:** Use these kits to upgrade the following lowers. A Shield Kit is also required; see manual 406876 to order the correct kit for your pump.

Kit	Lower
24F064 (CST)	253061 (1000cc)
	253062 (1500cc)
	253063 (2000cc)

**NOTE:** See page 2 for drawing of pump assembly showing kit parts and location.

Kit	Lower
24F063 (SST)	253033 (1000cc)
	253034 (1500cc)
	253035 (2000cc)
	253085 (1500cc)
	253086 (2000cc)
	253396 (2000cc)
	253397 (1500cc)
	253398 (1000cc)
	253423 (1000cc)
	253520 (1000cc)
	253521 (1500cc)
	253522 (2000cc)
	253523 (1000cc)
	253524 (1500cc)
	253525 (2000cc)
	253568 (1000cc)
	253569 (1500cc)
	253570 (2000cc)
	24E783 (1000cc)
	24E784 (1500cc)
24E785 (2000cc)	

Ref.	Description	Qty
2	O-RING; ptfе	6
4	GASKET, cylinder, 1000 cc size	2
	GASKET, cylinder, 1500 cc size	2
	GASKET, cylinder, 2000 cc size	2
7	GASKET, seat; UHMWPE	2
16	HOUSING, outlet; sst	1
	HOUSING, outlet; cst	1
17	ROD, piston	1
19	GLAND, male	2
20	V-PACKING; UHMWPE	5
25	V-PACKING; leather	3
26	GLAND, female	1
35	O-RING; ptfе	1
39	SPACER	1
40	CARTRIDGE, packing, throat	1
41	WET-CUP	1
42	O-RING; ptfе	1
43	SPRING	1
47	O-RING	2
49	COVER, wet-cup	1

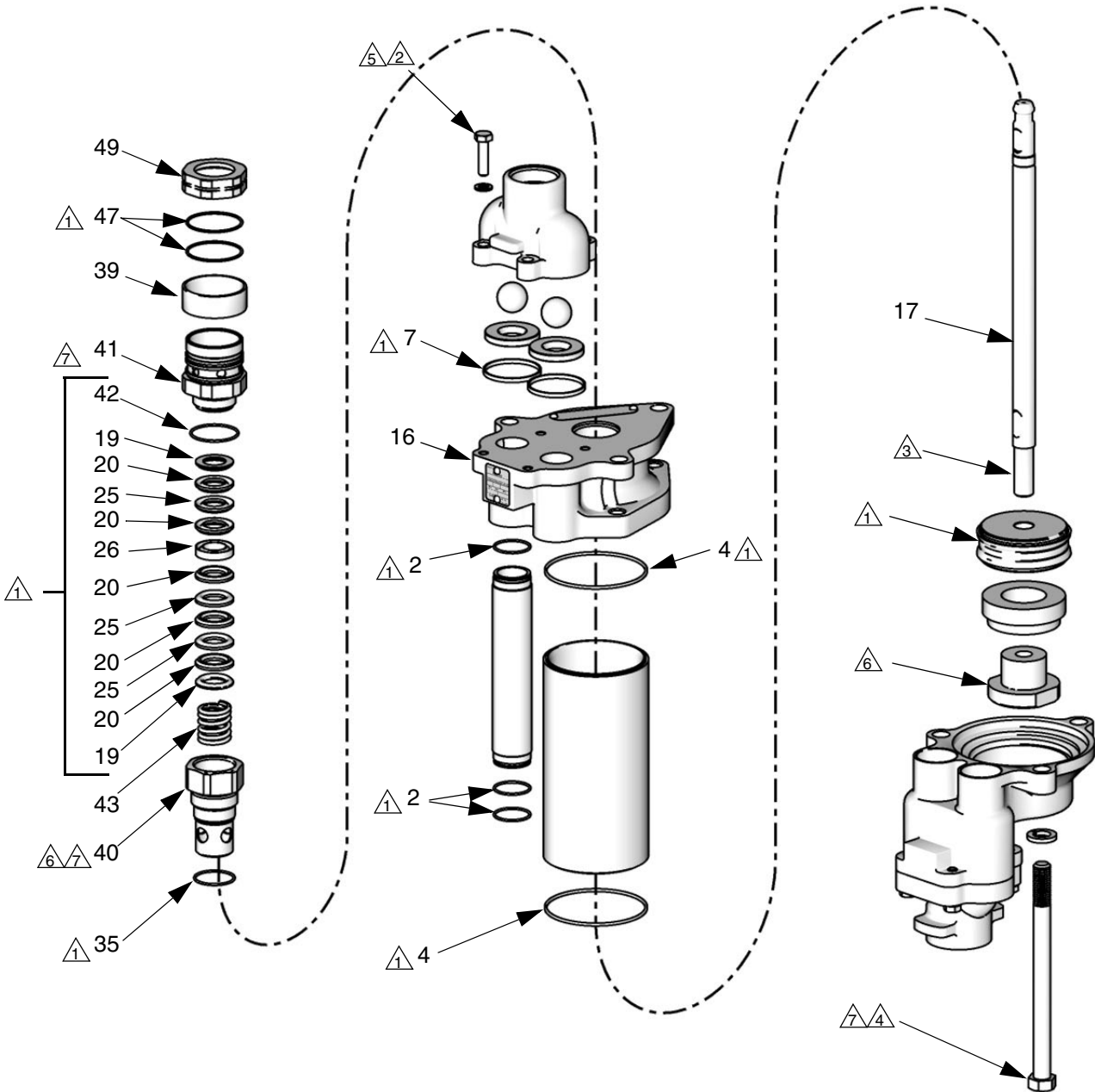

ti15546b

△1 Apply lubricant to all packings.

△2 Apply removable (blue) Loctite® 243 to entire length of threads. Sealant must be allowed to cure for a minimum of 12 hours before use.

△3 Apply high strength (red) Loctite® 263 or 2760 to entire length of threads. Sealant must be allowed to cure for a minimum of 12 hours before use.

△4 Tighten uniformly until cylinder (4) is seated. Torque to 25-30 ft-lb (34-40 N•m).

△5 Torque 25-30 ft-lb (34-40 N•m).

△6 Torque 95-100 ft-lb (129-135 N•m).

△7 Apply thread lubricant.

All written and visual data contained in this document reflects the latest product information available at the time of publication. Graco reserves the right to make changes at any time without notice.

Original instructions. This manual contains English. MM 406864

**Graco Headquarters:** Minneapolis  
**International Offices:** Belgium, China, Japan, Korea

**GRACO INC. AND SUBSIDIARIES • P.O. BOX 1441 • MINNEAPOLIS, MN 55440-1441 • USA**

**Copyright 2010, Graco Inc. All Graco manufacturing locations are registered to ISO 9001.**

www.graco.com  
 Revised 09/2011