

Instructions—Parts List



SEVERE-DUTY

Stainless Steel Pumps

308106G

For airless and air-assisted spraying of finishing materials.



Important Safety Instructions
Read all warnings and instructions in this manual.
Save these instructions.

See page 2 for Table of Contents.

Part No. 223843, Series A 30:1 Ratio President® Pump

3600 psi (25.0 MPa, 250 bar) Maximum Fluid Working Pressure
120 psi (0.8 MPa, 8 bar) Maximum Air Input Pressure

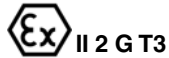

Part No. 223844, Series A 15:1 Ratio Monark® Pump

2700 psi (18.5 MPa, 185 bar) Maximum Fluid Working Pressure
180 psi (1.25 MPa, 12.5 bar) Maximum Air Input Pressure

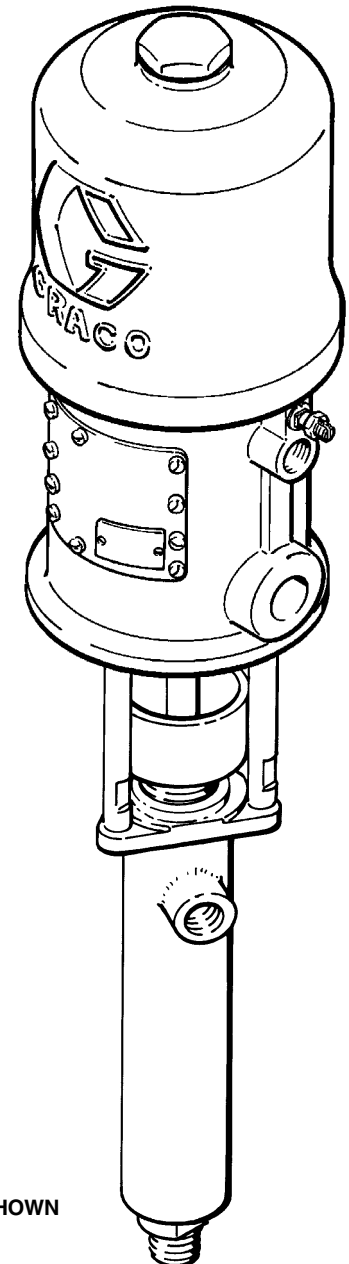
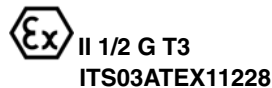

MODEL 223843 SHOWN



Table of Contents

Warnings	2
Installation	6
Operation	9
Troubleshooting	12
Parts	16
Technical Data	20
Mounting Hole Layout	22
Graco Standard Warranty	24
Graco Information	24

Symbols

Warning Symbol



This symbol alerts you to the possibility of serious injury or death if you do not follow the instructions.

Caution Symbol



This symbol alerts you to the possibility of damage to or destruction of equipment if you do not follow the corresponding instructions.

WARNING



INSTRUCTIONS

EQUIPMENT MISUSE HAZARD

Equipment misuse can cause the equipment to rupture or malfunction and result in serious injury.

- This equipment is for professional use only.
- Read all instruction manuals, tags, and labels before operating the equipment.
- Use the equipment only for its intended purpose. If you are uncertain about usage, call your Graco distributor.
- Do not alter or modify this equipment. Use only genuine Graco parts and accessories.
- Check equipment daily. Repair or replace worn or damaged parts immediately.
- Do not exceed the maximum working pressure of the lowest rated system component. Refer to the **Technical Data** on pages 20 and 21 for the maximum working pressure of this equipment.
- Use fluids and solvents which are compatible with the equipment wetted parts. Refer to the **Technical Data** section of all equipment manuals. Read the fluid and solvent manufacturer's warnings.
- Do not use hoses to pull equipment.
- Route hoses away from traffic areas, sharp edges, moving parts, and hot surfaces. Do not expose Graco hoses to temperatures above 82°C (180°F) or below -40°C (-40°F).
- Wear hearing protection when operating this equipment.
- Do not lift pressurized equipment.
- Comply with all applicable local, state, and national fire, electrical, and safety regulations.



TOXIC FLUID HAZARD

Hazardous fluid or toxic fumes can cause serious injury or death if splashed in the eyes or on the skin, inhaled, or swallowed.

- Know the specific hazards of the fluid you are using.
- Store hazardous fluid in an approved container. Dispose of hazardous fluid according to all local, state and national guidelines.
- Always wear protective eyewear, gloves, clothing and respirator as recommended by the fluid and solvent manufacturer.



MOVING PARTS HAZARD

Moving parts, such as the air motor piston, can pinch or amputate your fingers.

- Keep clear of all moving parts when starting or operating the pump.
- Before servicing the equipment, follow the **Pressure Relief Procedure** on page 9 to prevent the equipment from starting unexpectedly.

WARNING



SKIN INJECTION HAZARD

Spray from the gun/valve, hose leaks, or ruptured components can inject fluid into your body and cause extremely serious injury, including the need for amputation. Fluid splashed in the eyes or on the skin can also cause serious injury.



- Fluid injected into the skin might look like just a cut, but it is a serious injury. **Get immediate medical attention.**
- Do not point the gun at anyone or at any part of the body.
- Do not put your hand or fingers over the spray tip.
- Do not stop or deflect leaks with your hand, body, glove or rag.
- Do not “blow back” fluid; this is not an air spray system.
- Always have the tip guard and the trigger guard on the gun when spraying.
- Be sure the gun trigger safety operates before spraying.
- Lock the gun trigger safety when you stop spraying.
- Follow the **Pressure Relief Procedure** on page 9 whenever you: are instructed to relieve pressure; stop spraying; clean, check, or service the equipment; and install or clean the spray tip.
- Tighten all fluid connections before operating the equipment.
- Check the hoses, tubes, and couplings daily. Replace worn, damaged, or loose parts immediately. Permanently coupled hoses cannot be repaired; replace the entire hose.
- Use only Graco approved hoses. Do not remove any spring guard that is used to help protect the hose from rupture caused by kinks or bends near the couplings.



FIRE AND EXPLOSION HAZARD

Improper grounding, poor ventilation, open flames or sparks can cause a hazardous condition and result in a fire or explosion and serious injury.



- Ground the equipment and the object being sprayed. Refer to **Grounding** on page 6.
- If there is any static sparking or you feel an electric shock while using this equipment, **stop spraying immediately**. Do not use the equipment until you identify and correct the problem.
- Provide fresh air ventilation to avoid the buildup of flammable fumes from solvents or the fluid being sprayed.
- Keep the spray area free of debris, including solvent, rags, and gasoline.
- Electrically disconnect all equipment in the spray area.
- Extinguish all open flames or pilot lights in the spray area.
- Do not smoke in the spray area.
- Do not turn on or off any light switch in the spray area while operating or if fumes are present.
- Do not operate a gasoline engine in the spray area.

Installation

Grounding

WARNING



FIRE AND EXPLOSION HAZARD

Before operating the pump, ground the system as explained below. Also read the section **FIRE AND EXPLOSION HAZARD** on page 4.



1. *Pump*: loosen the grounding lug locknut (W) and washer (X). Insert one end of a 12 ga (1.5 mm²) minimum ground wire (Y) into the slot in lug (Z) and tighten the locknut securely. See Fig. 1. Connect the other end of the wire to a true earth ground. Order Part No. 237569, Ground Wire and Clamp.
2. *Air and fluid hoses*: use only electrically conductive hoses with a maximum of 500 ft (150 m) combined hose length to ensure grounding continuity.
3. *Air compressor*: follow manufacturer's recommendations.
4. *Spray gun*: grounding is obtained through connection to a properly grounded fluid hose and pump.

5. *Object being sprayed*: according to your local code.
6. *Fluid supply container*: according to your local code.
7. *All solvent pails used when flushing*, according to your local code. Use only metal pails, which are conductive, placed on a grounded surface. Do not place the pail on a nonconductive surface, such as paper or cardboard, which interrupts the grounding continuity.
8. *To maintain grounding continuity when flushing or relieving pressure*, always hold a metal part of the spray gun firmly to the side of a grounded metal pail, then trigger the gun.

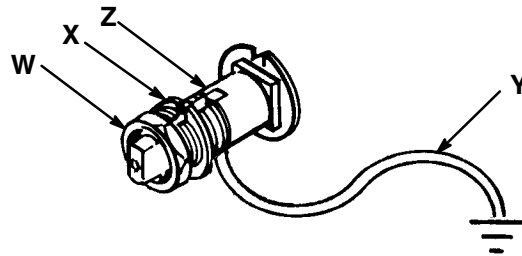
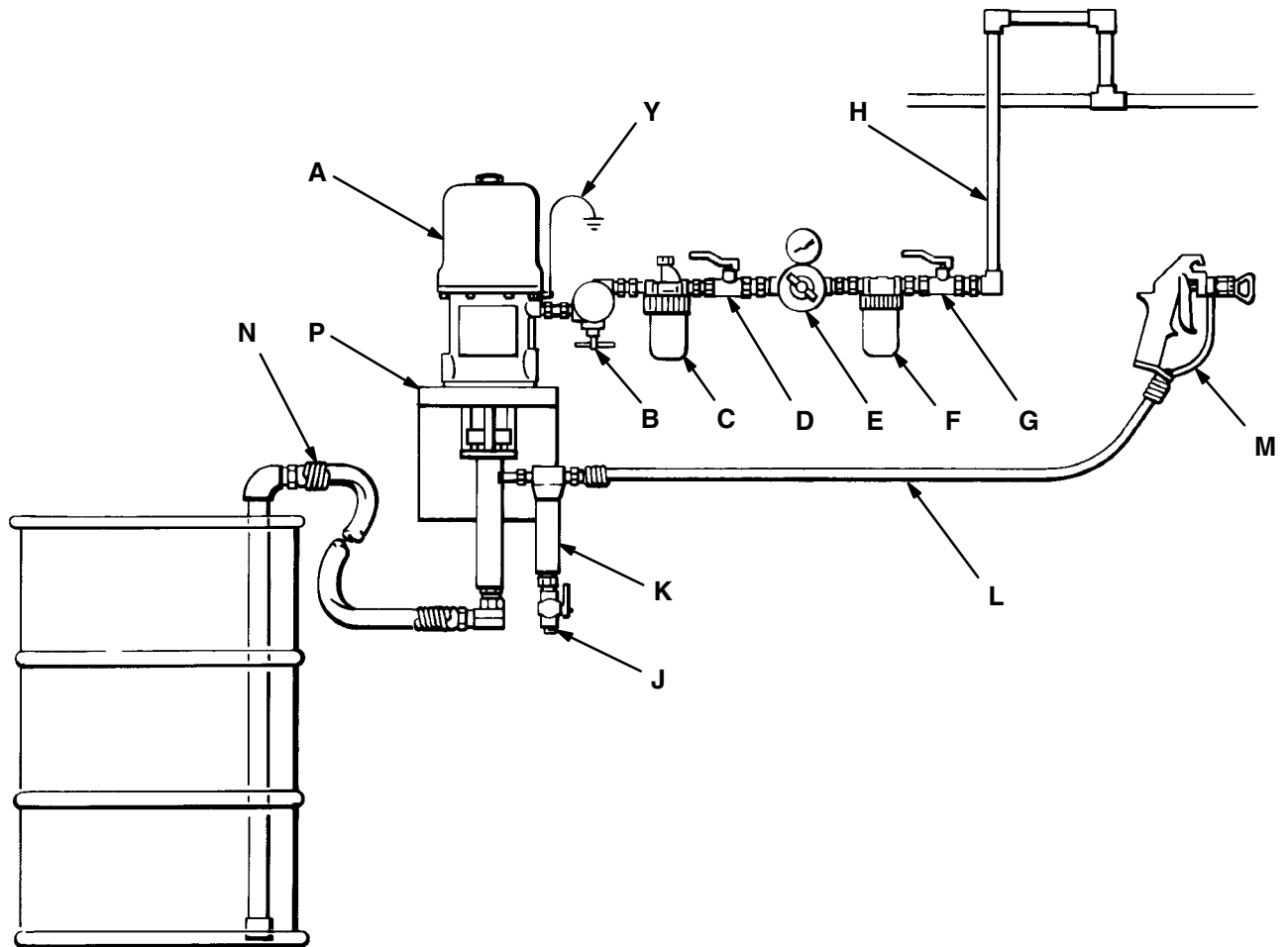

Fig. 1

Installation

Typical Installation



KEY

- A Pump
- B Pump Runaway Valve
- C Air Line Lubricator
- D Bleed-Type Master Air Valve (required, for pump)
- E Pump Air Regulator
- F Air Line Filter
- G Bleed-Type Master Air Valve (for accessories)
- H Air Supply Hose
- J Fluid Drain Valve (required)
- K Fluid Filter
- L Fluid Supply Hose
- M Spray Gun
- N Fluid Suction Hose
- P Wall Bracket
- Y Ground Wire (required)

Installation

NOTE: Reference numbers and letters in parentheses in the text refer to the callouts in the figures and the parts drawing.

Contact your Graco distributor for available accessories. If you supply your own accessories, be sure they are adequately sized and pressure-rated to meet the system's requirements.

The Typical Installation shown on page 7 is only a guide for selecting and installing system components and accessories. Contact your Graco distributor for assistance in designing a system to suit your particular needs.

System Accessories

Refer to the Typical Installation drawing on page 7.

WARNING

Two accessories are required in your system: a bleed-type master air valve (D) and a fluid drain valve (J). These accessories help reduce the risk of serious injury including splashing in the eyes or on the skin, and injury from moving parts if you are adjusting or repairing the pump.

The bleed-type master air valve relieves air trapped between this valve and the pump after the air is shut off. Trapped air can cause the pump to cycle unexpectedly. Locate the valve close to the pump.

The fluid drain valve assists in relieving pressure in the displacement pump, hose, and gun. Triggering the gun to relieve pressure may not be sufficient.

Mounting Accessories

Mount the pump (A) to suit the type of installation planned. The pump dimensions and mounting hole layout are shown on page 22.

Air and Fluid Hoses

Be sure all air and fluid hoses are properly sized and pressure-rated for your system. Use only grounded air and fluid hoses. Fluid hoses must have spring guards on both ends.

Connect a grounded fluid hose (L) to the pump's 3/8 npt(f) fluid outlet. Use of a short whip hose between the main fluid hose (L) and the gun (M) allows freer gun movement.

Connect a fluid suction hose (N) to the pump's 3/4 npt(m) fluid intake.

Use a grounded 1/2 in. I.D. (minimum) air hose (H) to supply air to the pump.

Air Line Accessories

Install the following accessories in the order shown in the Typical Installation, using adapters as necessary:

- **A pump runaway valve (B)** senses when the pump is running too fast and automatically shuts off the air to the motor. A pump which runs too fast can be seriously damaged. Install closest to the pump air inlet.
- **An air line lubricator (C)** provides automatic air motor lubrication.
- **A bleed-type master air valve (D)** is required in your system to relieve air trapped between it and the air motor when the valve is closed (see the **WARNING** at left). Be sure the bleed valve is easily accessible from the pump, and is located **downstream** from the air regulator.
- **An air regulator (E)** controls pump speed and outlet pressure by adjusting the air pressure to the pump. Locate the regulator close to the pump, but **upstream** from the bleed-type master air valve.
- **An air line filter (F)** removes harmful dirt and moisture from the compressed air supply.
- **A second bleed-type air valve (G)** isolates the air line accessories for servicing. Locate upstream from all other air line accessories.

Fluid Line Accessories

Install the following accessories in the positions shown in the Typical Installation, using adapters as necessary:

- **A fluid drain valve (J)** is required in your system to relieve fluid pressure in the hose and gun (see the **WARNING** at left). Install the drain valve pointing down, but so the handle points up when opened.
- **A fluid filter (K)** filters harmful particles from the fluid.
- **A spray gun (M)** dispenses the fluid. The gun shown in the Typical Installation is an airless spray gun.

Operation

Pressure Relief Procedure

⚠ WARNING

 **SKIN INJECTION HAZARD**
Fluid under high pressure can be injected through the skin and cause serious injury. To reduce the risk of an injury from injection, splashing fluid, or moving parts, follow the **Pressure Relief Procedure** whenever you:

- are instructed to relieve the pressure,
- stop spraying,
- check or service any of the system equipment,
- or install or clean the spray tip.

1. Lock the spray gun trigger safety.
2. Shut off the air to the pump.

3. Close the bleed-type master air valve (required in your system).
4. Unlock the spray gun trigger safety.
5. Hold a metal part of the gun firmly to the side of a grounded metal pail, and trigger the gun to relieve pressure.
6. Lock the spray gun trigger safety.
7. Open the drain valve (required in your system), having a container ready to catch the drainage.
8. Leave the drain valve open until you are ready to spray again.

If you suspect that the spray tip or hose is completely clogged, or that pressure has not been fully relieved after following the steps above, very slowly loosen the tip guard retaining nut or hose end coupling and relieve pressure gradually, then loosen completely. Now clear the tip or hose.

Operation

WARNING

Moving parts can pinch or amputate your fingers or other body parts. When air is supplied to the motor, the air motor piston (located behind the air motor plates) moves. See Fig. 2. Therefore, never operate the pump with the air motor plates removed.

Flush the Pump Before Using

The pump is tested with lightweight motor oil, which is left in to protect the pump parts. If the fluid you are using may be contaminated by the oil, flush it out with a compatible solvent before using the pump. If the pump is being used to supply a circulating system, allow the solvent to circulate until the pump is thoroughly flushed.

WARNING



FIRE AND EXPLOSION HAZARD

Before operating the pump, ground the system as explained in **Grounding** on page 6. Also read the section **FIRE AND EXPLOSION HAZARD** on page 4.

Starting and Adjusting the Pump

See the **Typical Installation** on page 7. Be sure the air regulator (E) and bleed-type master air valve (D) are closed. **DO NOT INSTALL THE SPRAY TIP YET!**

Connect a suction hose (N) to the pump's fluid inlet. Hold a metal part of the spray gun (M) firmly to the side of a grounded metal pail and hold the trigger open. Then open the pump's bleed-type master air valve (D). Now slowly open the air regulator until the pump starts, about 40 psi (280 kPa, 2.8 bar).

Cycle the pump slowly until all the air is pushed out and the pump and hoses are fully primed. Release the spray gun trigger and engage the safety latch. The pump should stall against pressure when the trigger is released.

WARNING

To reduce the risk of serious injury whenever you are instructed to relieve pressure, always follow the **Pressure Relief Procedure** on page 9.

Relieve the pressure, then install the spray tip in the gun.

With the pump and lines primed, and with adequate air pressure and volume supplied, the pump will start and stop as the spray gun is opened and closed. In a circulating system, the pump will run continuously and will speed up or slow down as supply demands until the air supply is shut off.

Use an adequately sized air regulator (E) to control the pump speed and the fluid pressure. Always use the lowest air pressure necessary to get the desired results. Higher pressures waste fluid and cause premature wear of the pump packings and spray tip.

WARNING

To reduce the risk of overpressurizing your system, which could result in component rupture and cause serious injury, never exceed the *Maximum Incoming Air Pressure* given on your pump or in the **Technical Data** on pages 20 and 21.

Keep the packing nut/wet-cup (4) filled with Graco Throat Seal Liquid (TSL) or compatible solvent, to help prolong the packing life. Adjust the packing nut weekly so it is just tight enough to prevent leakage; do not overtighten. See Fig. 2. Always **relieve the pressure** before adjusting the packing nut.

Never allow the pump to run dry of the fluid being pumped. A dry pump will quickly accelerate to a high speed, possibly damaging itself. A pump runaway valve (B), which shuts off the air supply to the pump if the pump accelerates beyond the pre-set speed, is available. See the **Typical Installation** on page 7. If your pump accelerates quickly, or is running too fast, stop it immediately and check the fluid supply. If the supply container is empty and air has been pumped into the lines, refill the container and prime the pump and the lines with fluid, or flush and leave it filled with a compatible solvent. Be sure to eliminate all air from the fluid system.

Operation

WARNING

To reduce the risk of serious injury whenever you are instructed to relieve pressure, always follow the **Pressure Relief Procedure** on page 9.

Shutdown and Care of the Pump

For overnight shutdown, **relieve the pressure**. Always stop the pump at the bottom of the stroke to prevent the fluid from drying on the exposed displacement rod and damaging the throat packings.

Always flush the pump before the fluid dries on the displacement rod. **Relieve the pressure** after flushing.

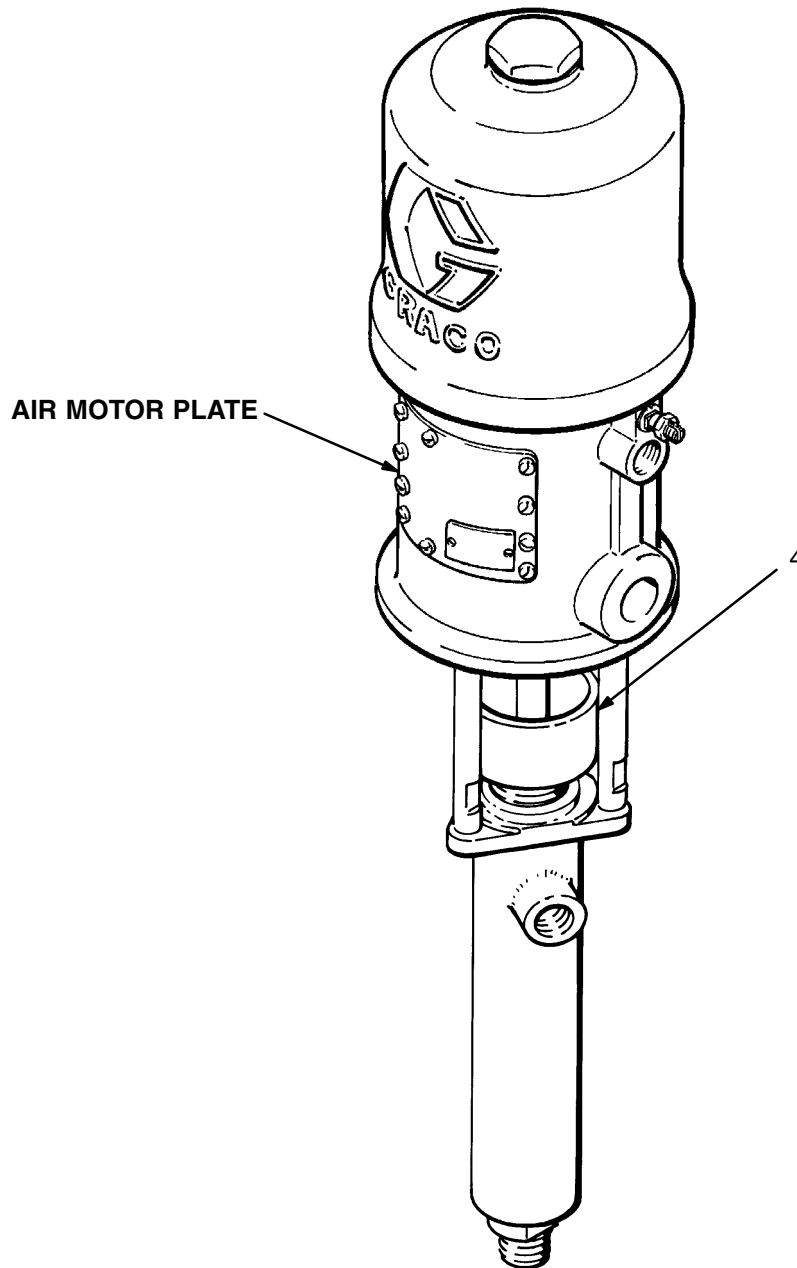

Fig. 2

Troubleshooting

WARNING

To reduce the risk of serious injury whenever you are instructed to relieve pressure, always follow the **Pressure Relief Procedure** on page 9.

1. Relieve the pressure.
2. Check all possible causes and problems before disassembling the pump.

PROBLEM	CAUSE	SOLUTION
Pump fails to operate	Restricted line or inadequate air supply	Clear; increase air supply.
	Insufficient air pressure; closed or clogged air valves, etc.	Open, clean.
	Exhausted fluid supply	Refill; purge all air from pump and fluid lines.
	Damaged air valving mechanism; stalling	Service air motor (see 306982 or 307043).
	Dried fluid seizure of displacement rod (19)	Clean, check or replace throat packings (8, 13); always stop pump at bottom of stroke and keep wet-cup filled with compatible solvent.
Pump operates, but output low on both strokes	Restricted line or inadequate air supply	Clear; increase air supply.
	Insufficient air pressure; closed or clogged air valves, etc.	Open, clean.
	Exhausted fluid supply	Refill; purge all air from pump and fluid lines.
	Clogged fluid line, valve, etc.	Clear.*
	Packing nut (4) too tight	Loosen (see page 10).
	Loose packing nut (4) or worn throat packings (8, 13).	Tighten packing nut (see page 10); replace throat packings
Pump operates, but output low in down stroke	Held open or worn intake valve	Clear; service.
Pump operates, but output low on up stroke	Held open or worn fluid piston valve or packings (8, 13).	Clear; service.
Erratic or accelerated operation	Exhausted fluid supply	Refill; purge all air from pump and fluid lines
	Held open or worn intake valve	Clear; service.
	Held open or worn fluid piston valve or packings (8, 13).	Clear; service.

* To determine if the fluid hose or gun is obstructed, **relieve the pressure**. Disconnect the fluid hose and place a container at the pump fluid outlet to catch any fluid. Turn on the air just enough to start the pump (about 20–40 psi [140–280 kPa, 1.4–2.8 bar]). If the pump starts when the air is turned on, the obstruction is in the fluid hose or gun.

Service

WARNING



To reduce the risk of serious injury whenever you are instructed to relieve pressure, always follow the **Pressure Relief Procedure** on page 9.

DISCONNECTING THE DISPLACEMENT PUMP

1. Flush the pump if possible. Stop the pump at the bottom of its stroke. **Relieve the pressure.**
2. Disconnect the air and fluid hoses. Remove the pump from its mounting. Note the relative position of the pump's fluid outlet to the air motor's air inlet.
3. Unscrew the tie rod locknuts (106) from the tie rods (110). Remove the cotter pin (105). Unscrew the displacement rod (19) from the air motor (101). Carefully pull the displacement pump (102) off the air motor (101). See Fig 3.
4. Refer to page 14 for displacement pump service. To service the air motor, refer to the separate air motor manual (306982 or 307043), supplied.

RECONNECTING THE DISPLACEMENT PUMP

1. Screw the displacement rod (19) into the base of the air motor (101). Install the cotter pin (105). Orient the pump's fluid outlet to the air motor's air inlet as was noted in step 2 under **Disconnecting the Displacement Pump**. See Fig 3.
2. Position the displacement pump (102) on the tie rods (110). Screw the locknuts (106) onto the tie rods (110) loosely.
3. Mount the pump and reconnect all hoses. Reconnect the ground wire if it was disconnected during repair. Torque the packing nut/wet-cup (4) to 18–20 ft-lb (24–27 N.m). Fill the wet-cup with Graco Throat Seal Liquid or compatible solvent.
4. Tighten the tie rod locknuts (106) evenly, and torque to 25–30 ft-lb (34–41 N.m).
5. Start the pump and run it at about 40 psi (280 kPa, 2.8 bar) air pressure, to check that it is operating properly.

- 1  Torque President to 25–30 ft-lb (34–41 N.m); Monark to 15–20 ft-lb (20–27 N.m)
- 2  Torque to 18–20 ft-lb (24–27 N.m)
- 3  Torque to 25–30 ft-lb (34–41 N.m)

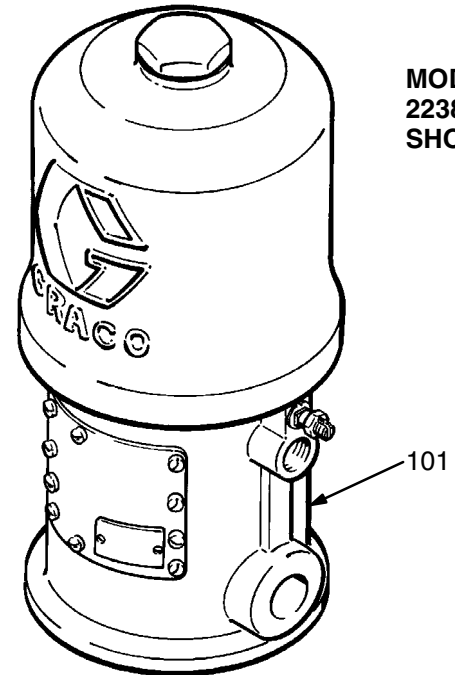

MODEL
223843
SHOWN

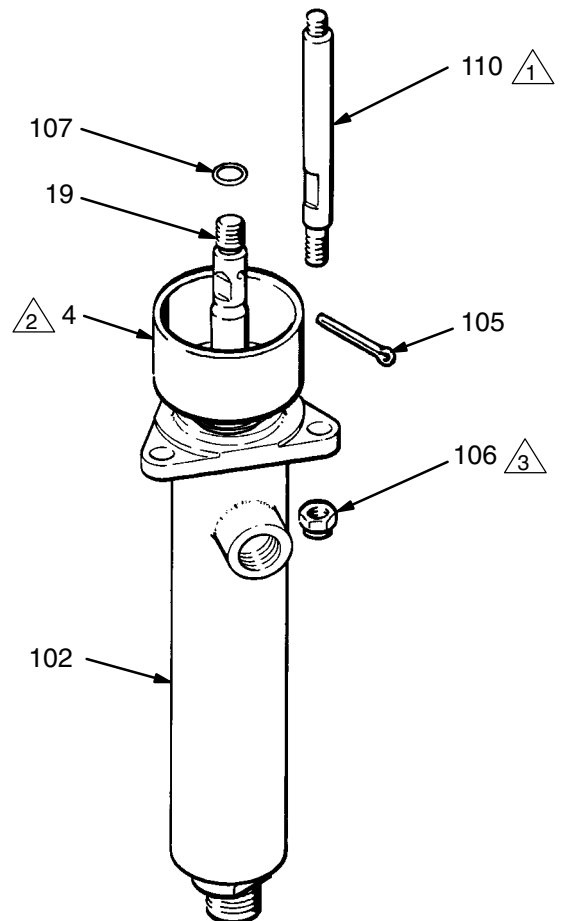

Fig. 3

Displacement Pump Service

Disassembly

When disassembling the pump, lay out all removed parts in sequence, to ease reassembly. Refer to Fig 4.

NOTE: Repair Kit 235635 is available. For the best results, use all the new parts in the kit. Parts included in the kit are denoted with one asterisk, for example (6*).

Clean all the parts thoroughly when disassembling. Check them carefully for damage or wear, replacing parts as needed.

1. Remove the displacement pump from the air motor as explained on page 13.
2. Unscrew the intake valve housing (1) from the outlet housing (3). If it is difficult to remove, squirt penetrating oil around the threads and *gently* tap around the valve housing with a plastic hammer to loosen it. See Fig 4.
3. Remove the ball stop pin (14), o-ring retainer (16), o-ring (15), guide (22) and ball (7) from the intake valve housing (1).
4. Loosen the packing nut (4). Push the displacement rod (19) down as far as possible, then pull it out the bottom of the outlet housing (3).
5. Secure the flats of the piston stud (2) in a vise. Using a wrench on the flats of the displacement rod (19), screw the rod off the piston. Remove the ball (6), retainer (12), packings (8, 13) and glands (17, 18).
6. Remove the packing nut (4), throat packings (8, 13) and glands (17, 18) from the outlet housing (3).
7. Inspect all parts for damage. Clean all parts and threads with a compatible solvent before reassembling. Inspect the polished surfaces of the displacement rod (19) and sleeve (10) for scratches, scoring or other damage, which can cause premature packing wear and leaking. To check, run a finger over the surface or hold the part up to the light at an angle. Be sure the ball seats of the piston (2) and intake valve housing (1) are not chipped or nicked. Replace any worn or damaged parts.

NOTE: If the sleeve (10) needs replacement and is hard to remove, contact your Graco distributor.

Reassembly

1. Lubricate the throat packings and install them in the outlet housing (3) one at a time as follows, *with the lips of the v-packings facing down*: the male gland (17*), one PTFE v-packing (13*), two leather v-packings (8*), one PTFE (13*), one leather (8*), one PTFE (13*), and the female gland (18*). Install the packing nut (4) loosely. See Fig 4.
2. If you removed the sleeve (10), reinstall it in the outlet housing (3), making sure to replace the gasket (9*). *Be sure the tapered end of the sleeve faces down, toward the pump intake.*
3. Lubricate the piston packings and install them onto the piston stud (2) one at a time in the following order, *with the lips of the v-packings facing up*: the female gland (18*), one PTFE v-packing (13*), two leather v-packings (8*), one PTFE (13*), one leather (8*), one PTFE (13*), the male gland (17*), and the packing retainer (12). See Fig 4.
4. DO NOT use thread sealant on the piston stud. Install the piston ball (6*) on the piston and screw the piston valve assembly into the displacement rod (19). Torque to 65–75 ft-lb (88–102 N.m).
5. Insert the displacement rod (19) into the bottom of the outlet housing (3), being careful not to scratch the sleeve (10). Push the rod straight up until it protrudes from the packing nut (4).
6. Install the ball (7*), guide (22), o-ring (15*), retainer (16), and ball stop pin (14) in the intake valve housing (1). Screw the intake housing into the outlet housing (3). Torque to 75–100 ft-lb (102–136 N.m).
7. Reconnect the displacement pump to the air motor as explained on page 13.

Service

- △1 Torque to 18–20 ft-lb (24–27 N.m)
- △2 Torque to 25–30 ft-lb (34–41 N.m)
- △3 Torque President to 25–30 ft-lb (34–41 N.m);
Monark to 15–20 ft-lb (20–27 N.m)
- △4 Torque to 65–75 ft-lb (88–102 N.m)
- △5 Torque to 75–100 ft-lb (102–136 N.m)
- △6 Lips of v-packings must face down
- △7 Lips of v-packings must face up

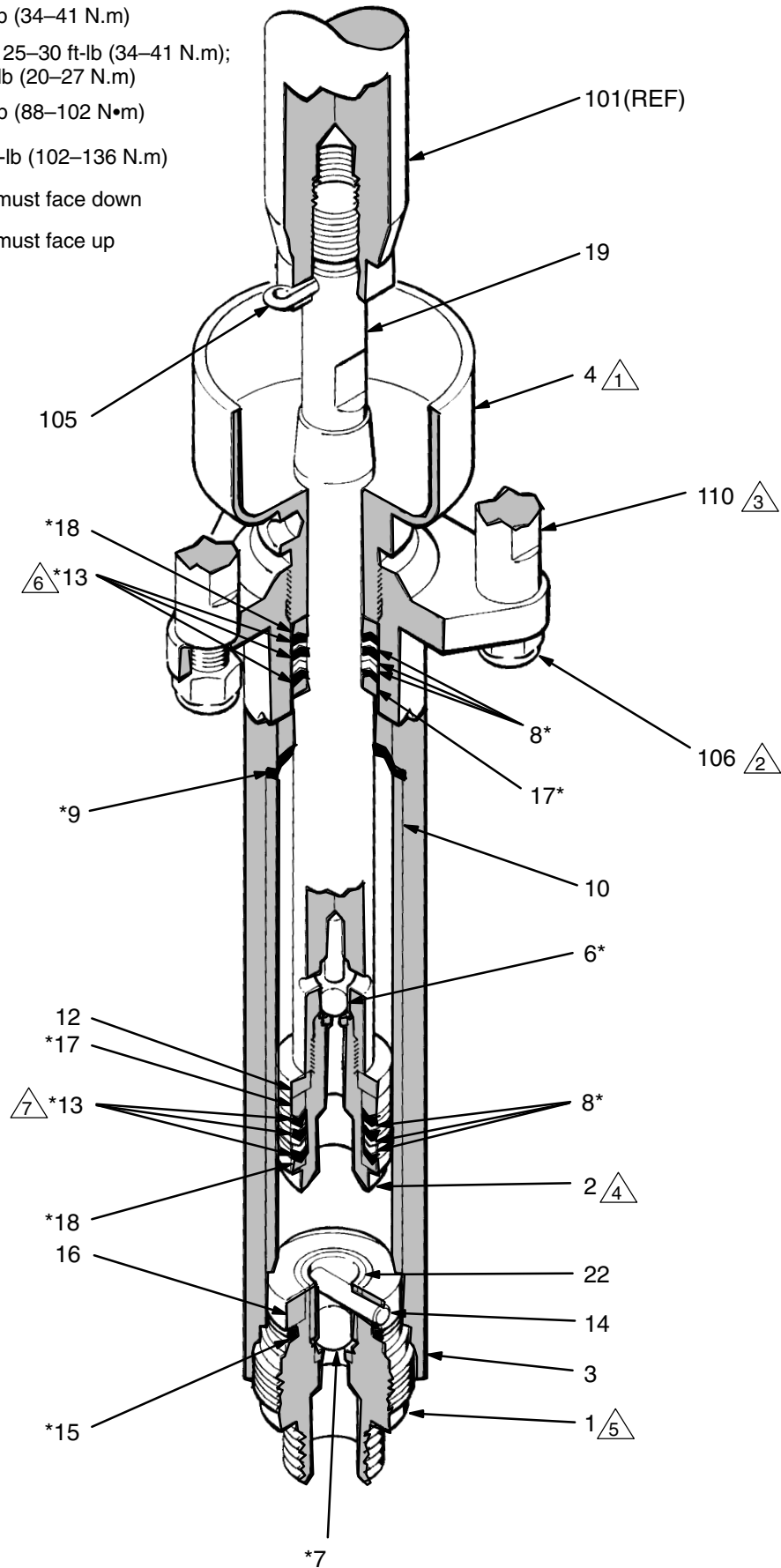

Fig. 4

Parts

Model 223843, Series A
30:1 Ratio President® Pump
 Includes items 101–110

REF NO.	PART NO.	DESCRIPTION	QTY
101	207352	AIR MOTOR See 306982 for parts	1
102	223842	DISPLACEMENT PUMP ASSY See pages 18 and 19 for parts	1
105†	101946	PIN, cotter; stainless steel; 0.12" (3.2 mm) x 1.5" (3.8 mm)	1
106	101566	NUT, lock; 3/8–16	3
107†	156082	SEAL, o-ring; nitrile rubber	1
110	168221	ROD, tie; carbon steel; 4.5" (114 mm) shoulder-to-shoulder	3

† Recommended "tool box" spare parts. Keep on hand to reduce downtime.

306 and 307 numbers in descriptions refer to separate instruction manuals, supplied.

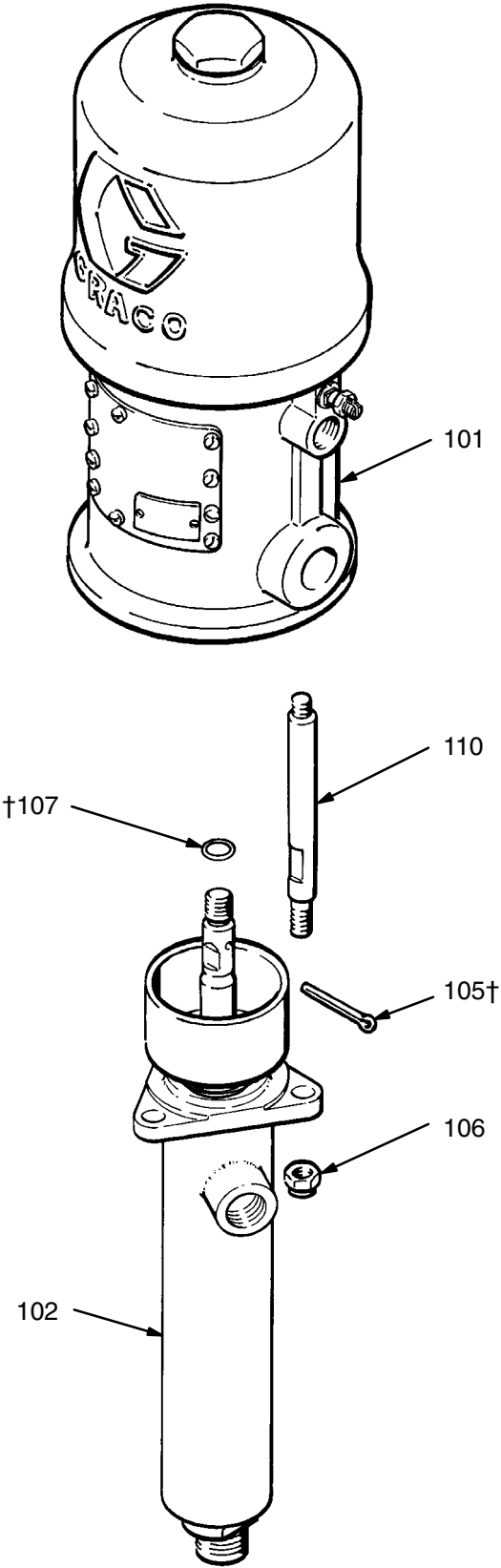

Parts

Model 223844, Series A
15:1 Ratio Monark® Pump
 Includes items 101–110

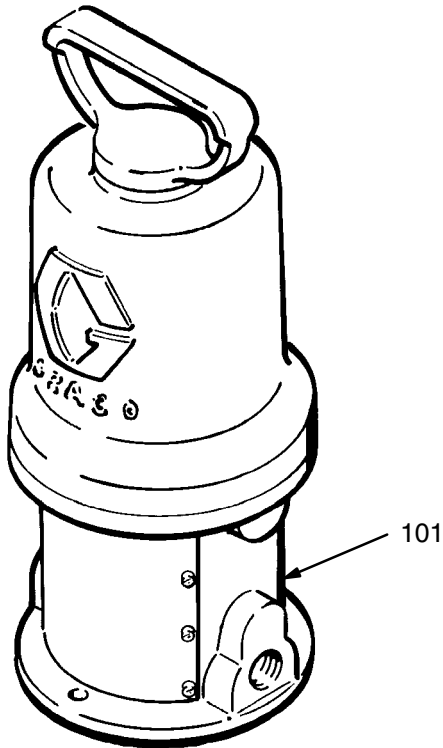

REF NO.	PART NO.	DESCRIPTION	QTY
101	215363	AIR MOTOR See 307043 for parts	1
102	223842	DISPLACEMENT PUMP ASSY See pages 18 and 19 for parts	1
105†	101946	PIN, cotter; stainless steel; 0.12" (3.2 mm) x 1.5" (3.8 mm)	1
106	101566	NUT, lock; 3/8–16	3
107†	156082	SEAL, o-ring; nitrile rubber	1
110	164722	ROD, tie; carbon steel; 4.375" (112 mm) shoulder-to-shoulder	3

† Recommended "tool box" spare parts. Keep on hand to reduce downtime.

306 and 307 numbers in descriptions refer to separate instruction manuals, supplied.

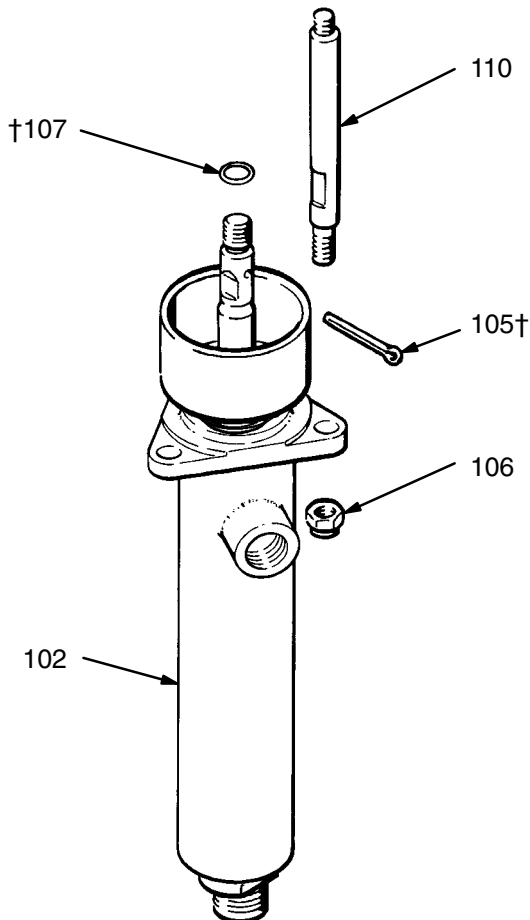

Parts

Model 223842, Series B
Severe-Duty, Stainless Steel Displacement Pump
Includes items 1-22

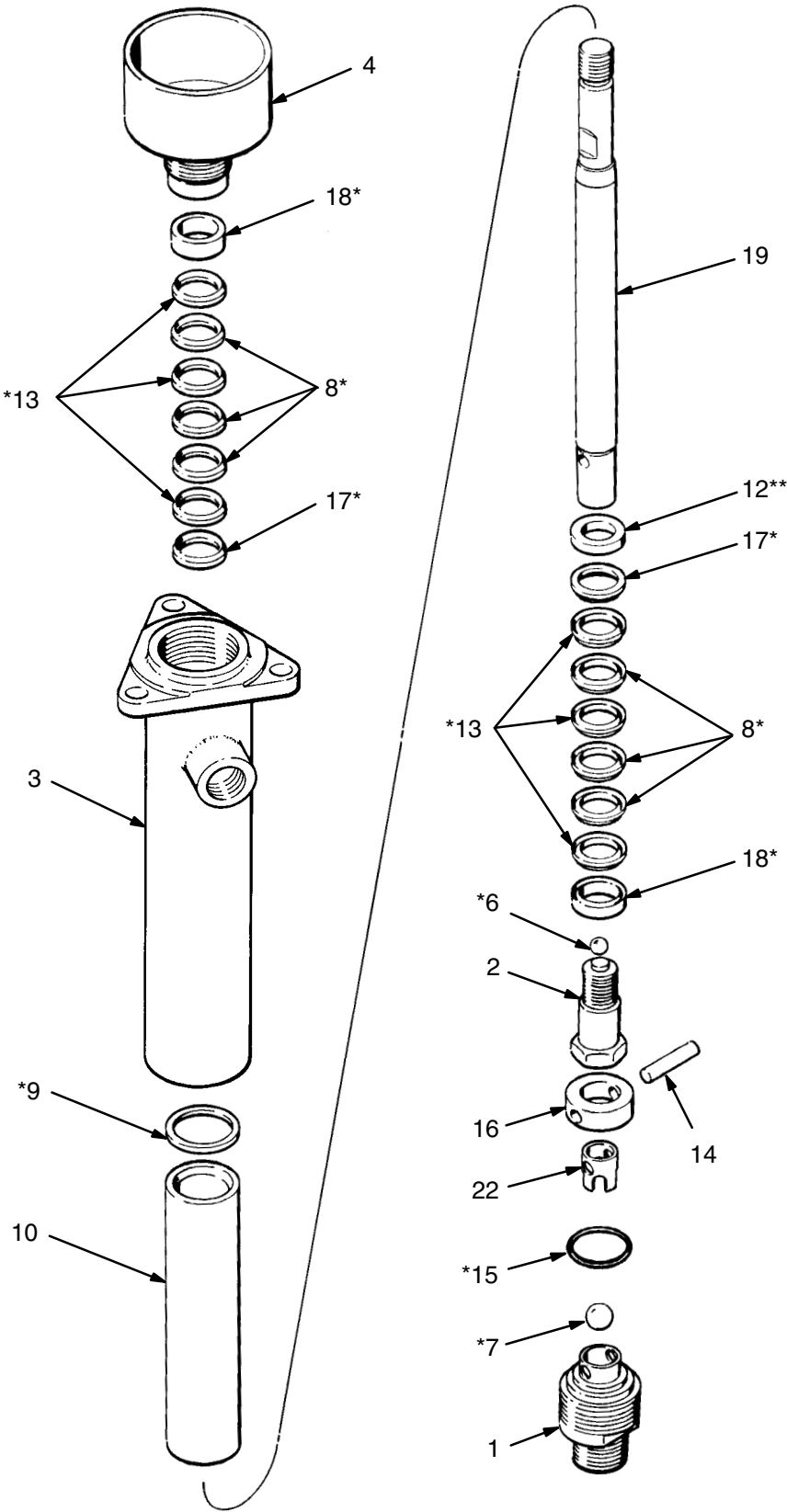

Parts

Model 223842, Series B
Severe-Duty, Stainless Steel Displacement Pump
 Includes items 1–22

REF NO.	PART NO.	DESCRIPTION	QTY	REF NO.	PART NO.	DESCRIPTION	QTY
1	223593	HOUSING, valve, intake; stainless steel with tungsten carbide seat	1	14	186179	PIN, ball stop; stainless steel	1
2	223565	STUD, piston; stainless steel with tungsten carbide seat	1	15*	165052	SEAL, o-ring; PTFE	1
3	239137	HOUSING, outlet; stainless steel	1	16	186183	RETAINER, o-ring; stainless steel	1
4	223590	PACKING NUT/WET-CUP; stainless steel	1	17*	186182	GLAND, packing, male; stainless steel	2
6*	105444	BALL, bearing; SST, 5/16 dia.	1	18*	186181	GLAND, packing, female; stainless steel	2
7*	105445	BALL, bearing; SST, 1/2 dia.	1	19	24C507	ROD, displacement; stainless steel	1
8*	164477	V-PACKING; leather	6	20	172479	TAG, warning (not shown)	1
9*	164480	GASKET, flat; PTFE	1	22	186187	GUIDE, ball; stainless steel	1
10	24C500	SLEEVE, housing; stainless steel	1	* Included in Repair Kit 235635.			
12†	186184	RETAINER, packing; stainless steel	1	† Recommended "tool box" spare parts. Keep on hand to reduce downtime.			
13*	164862	V-PACKING; PTFE	6	306 and 307 numbers in descriptions refer to separate instruction manuals, supplied.			

Technical Data

Maximum fluid working pressure	3600 psi (25.0 MPa, 250 bar)
Maximum air input pressure	120 psi (0.8 MPa, 8 bar)
Pump cycles per 1 gallon (3.8 liters)	60
Maximum flow at 60 cycles/min	1 gallon (3.8 liters)
Recommended speed for optimum pump life	15–25 cycles/min;
	0.25 to 0.42 gpm (0.9 to 1.6 liters/min)
Air consumption	approx. 35 scfm (0.98 m ³ /min)
	at 1 gpm (3.8 liters/min) at 100 psi (0.7 MPa, 7 bar) air pressure
Weight	approx. 24 lb (11 kg)
Wetted parts	AISI 304, 316, 420, and 17–4 PH grades of Stainless Steel; Chrome Plating; Tungsten Carbide; PTFE; Leather

KEY: Fluid Outlet Pressure – Black Curves
Air Consumption – Gray Curves

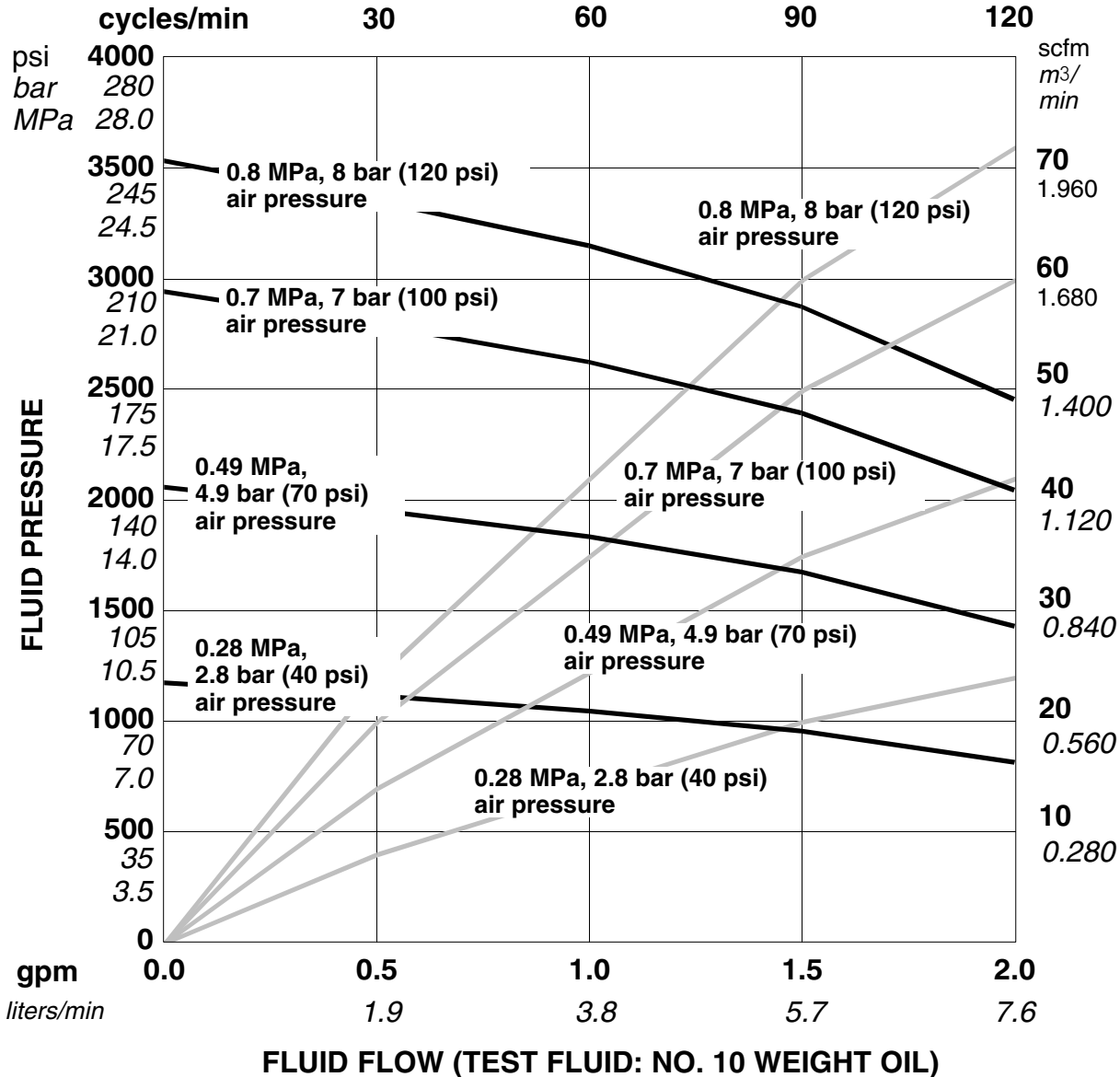

To find Fluid Outlet Pressure (bar/psi) at a specific fluid flow (lpm/gpm) and operating air pressure (bar/psi):

1. Locate desired flow along bottom of chart.
2. Follow vertical line up to intersection with selected fluid outlet pressure curve (black). Follow left to scale to read fluid outlet pressure.

To find Pump Air Consumption (m³/min or scfm) at a specific fluid flow (lpm/gpm) and air pressure (bar/psi):

1. Locate desired flow along bottom of chart.
2. Read vertical line up to intersection with selected air consumption curve (gray). Follow right to scale to read air consumption.

Technical Data

Maximum fluid working pressure 2700 psi (18.5 MPa, 185 bar)
 Maximum air input pressure 180 psi (1.25 MPa, 12.5 bar)
 Pump cycles per 1 gallon (3.8 liters) 84
 Maximum flow at 60 cycles/min 0.75 gallon (2.8 liters)
 Recommended speed for optimum pump life 15–25 cycles/min;
 0.18 to 0.30 gpm (0.7 to 1.14 liters/min)
 Air consumption approx. 16 scfm (0.45 m³/min)
 at 1 gpm (3.8 liters/min) at 100 psi (0.7 MPa, 7 bar) air pressure
 Weight approx. 24 lb (11 kg)
 Wetted parts AISI 304, 316, 420, and 17–4 PH grades of Stainless Steel;
 Chrome Plating; Tungsten Carbide; PTFE; Leather

KEY: Fluid Outlet Pressure – Black Curves
 Air Consumption – Gray Curves

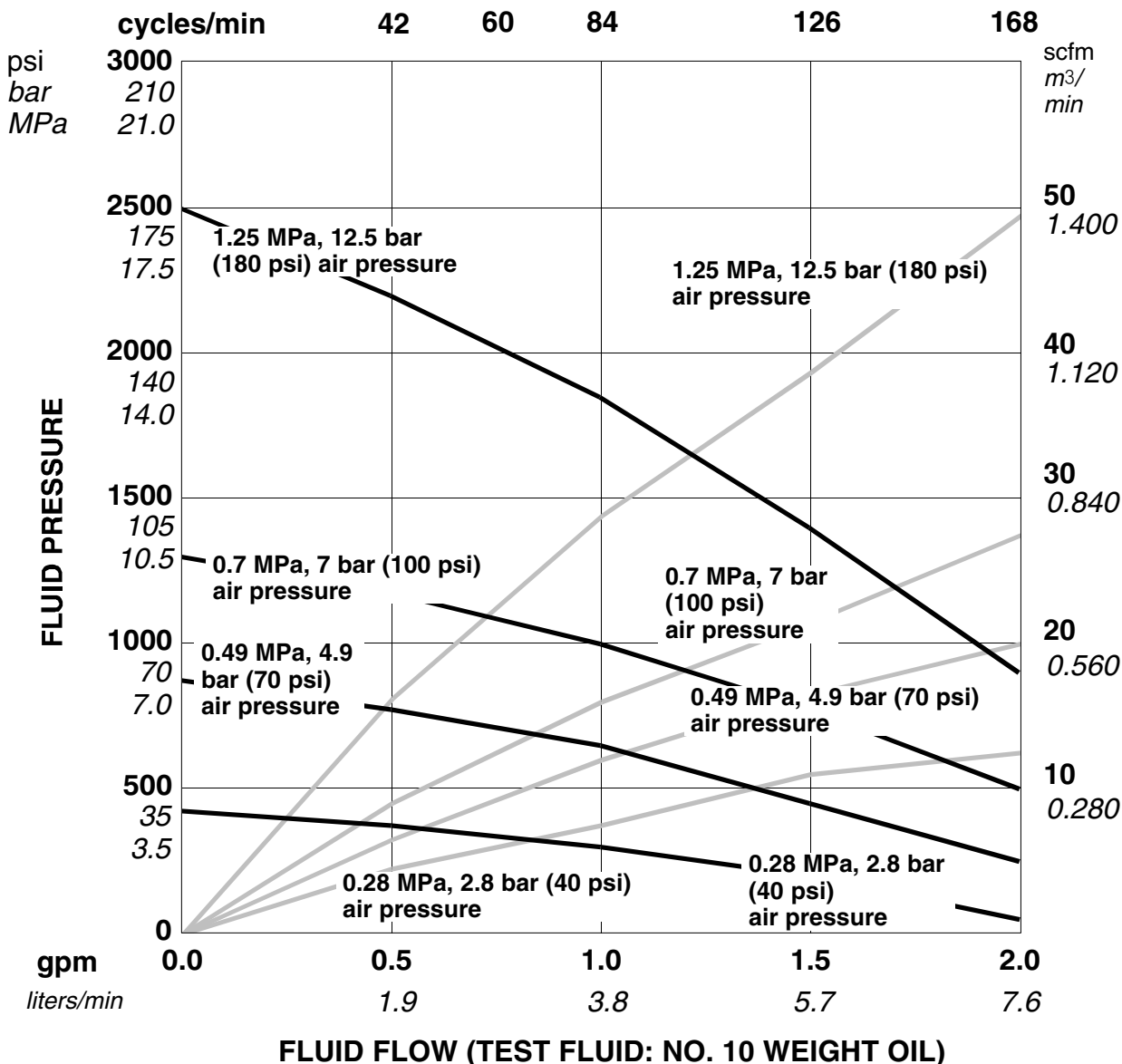

To find Fluid Outlet Pressure (bar/psi) at a specific fluid flow (lpm/gpm) and operating air pressure (bar/psi):

1. Locate desired flow along bottom of chart.
2. Follow vertical line up to intersection with selected fluid outlet pressure curve (black). Follow left to scale to read fluid outlet pressure.

To find Pump Air Consumption (m³/min or scfm) at a specific fluid flow (lpm/gpm) and air pressure (bar/psi):

1. Locate desired flow along bottom of chart.
2. Read vertical line up to intersection with selected air consumption curve (gray). Follow right to scale to read air consumption.

Dimensions

Model 223843 Shown

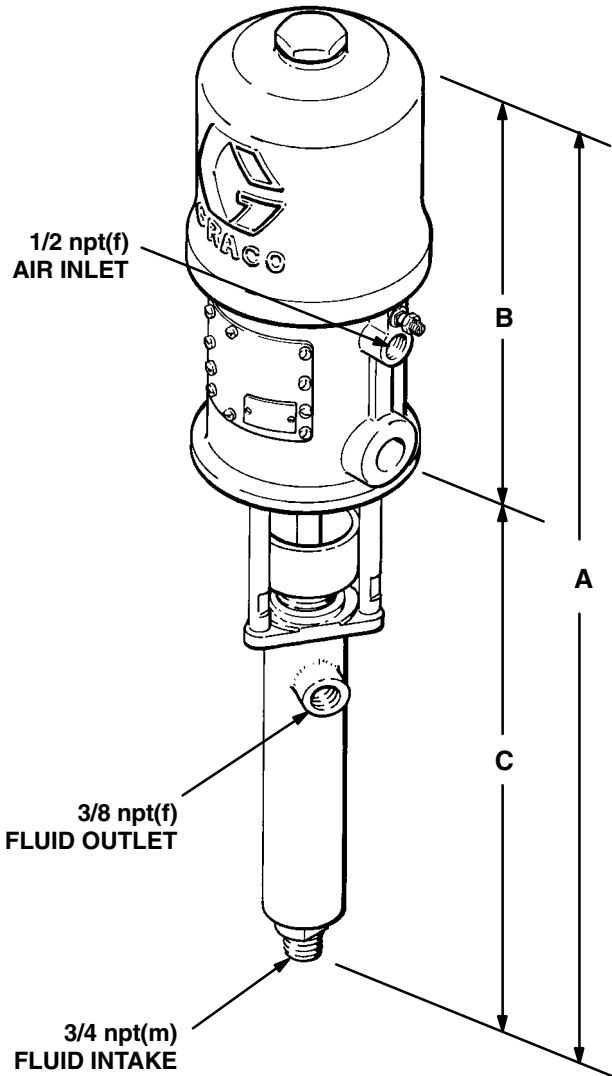

Mounting Hole Layout

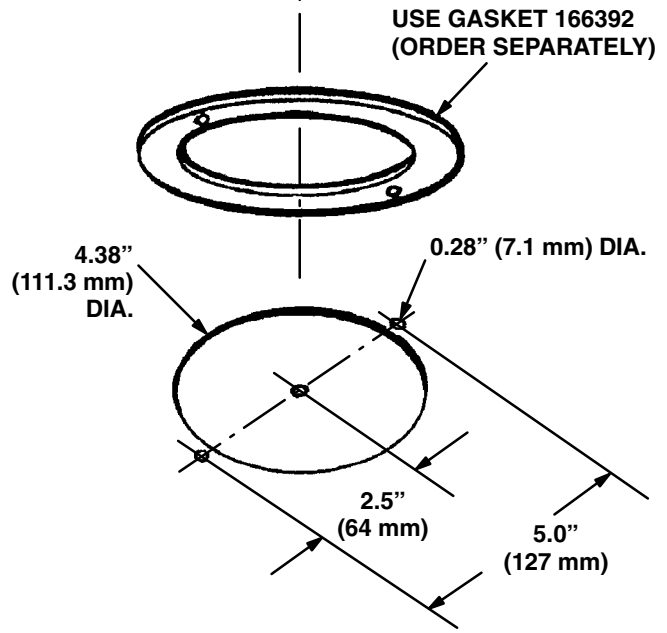

Pump Model	A	B	C
223843	30 in. (762 mm)	14.8 in. (376 mm)	15.2 in. (386 mm)
223844	28.4 in. (722 mm)	13.3 in. (338 mm)	15.1 in. (384 mm)

Graco Standard Warranty

Graco warrants all equipment manufactured by Graco and bearing its name to be free from defects in material and workmanship on the date of sale to the original purchaser for use. With the exception of any special, extended, or limited warranty published by Graco, Graco will, for a period of twelve months from the date of sale, repair or replace any part of the equipment determined by Graco to be defective. This warranty applies only when the equipment is installed, operated and maintained in accordance with Graco's written recommendations.

This warranty does not cover, and Graco shall not be liable for general wear and tear, or any malfunction, damage or wear caused by faulty installation, misapplication, abrasion, corrosion, inadequate or improper maintenance, negligence, accident, tampering, or substitution of non-Graco component parts. Nor shall Graco be liable for malfunction, damage or wear caused by the incompatibility of Graco equipment with structures, accessories, equipment or materials not supplied by Graco, or the improper design, manufacture, installation, operation or maintenance of structures, accessories, equipment or materials not supplied by Graco.

This warranty is conditioned upon the prepaid return of the equipment claimed to be defective to an authorized Graco distributor for verification of the claimed defect. If the claimed defect is verified, Graco will repair or replace free of charge any defective parts. The equipment will be returned to the original purchaser transportation prepaid. If inspection of the equipment does not disclose any defect in material or workmanship, repairs will be made at a reasonable charge, which charges may include the costs of parts, labor, and transportation.

THIS WARRANTY IS EXCLUSIVE, AND IS IN LIEU OF ANY OTHER WARRANTIES, EXPRESS OR IMPLIED, INCLUDING BUT NOT LIMITED TO WARRANTY OF MERCHANTABILITY OR WARRANTY OF FITNESS FOR A PARTICULAR PURPOSE.

Graco's sole obligation and buyer's sole remedy for any breach of warranty shall be as set forth above. The buyer agrees that no other remedy (including, but not limited to, incidental or consequential damages for lost profits, lost sales, injury to person or property, or any other incidental or consequential loss) shall be available. Any action for breach of warranty must be brought within two (2) years of the date of sale.

Graco makes no warranty, and disclaims all implied warranties of merchantability and fitness for a particular purpose in connection with accessories, equipment, materials or components sold but not manufactured by Graco. These items sold, but not manufactured by Graco (such as electric motors, switches, hose, etc.), are subject to the warranty, if any, of their manufacturer. Graco will provide purchaser with reasonable assistance in making any claim for breach of these warranties.

In no event will Graco be liable for indirect, incidental, special or consequential damages resulting from Graco supplying equipment hereunder, or the furnishing, performance, or use of any products or other goods sold hereto, whether due to a breach of contract, breach of warranty, the negligence of Graco, or otherwise.

FOR GRACO CANADA CUSTOMERS

The parties acknowledge that they have required that the present document, as well as all documents, notices and legal proceedings entered into, given or instituted pursuant hereto or relating directly or indirectly hereto, be drawn up in English. Les parties reconnaissent avoir convenu que la rédaction du présente document sera en Anglais, ainsi que tous documents, avis et procédures judiciaires exécutés, donnés ou intentés à la suite de ou en rapport, directement ou indirectement, avec les procédures concernées.

Graco Information

For the latest information about Graco products, visit www.graco.com.

TO PLACE AN ORDER, contact your Graco distributor, or call one of the following numbers to identify the distributor closest to you:

1-800-328-0211 Toll Free

612-623-6921

612-378-3505 Fax

All written and visual data contained in this document reflects the latest product information available at the time of publication. Graco reserves the right to make changes at any time without notice.

This manual contains English. MM 308106

Graco Headquarters: Minneapolis

International Offices: Belgium, China, Japan, Korea

GRACO INC. P.O. BOX 1441 MINNEAPOLIS, MN 55440-1441

Copyright 1991, Graco Inc. is registered to ISO 9001

www.graco.com

Revised 07/2009