

## GH<sup>TM</sup> Power Pack

334914B

EN

**Use to power XP-h<sup>TM</sup> Hydraulic Plural-Component Sprayers. For professional use only.**  
**Not approved for use in explosive atmospheres or hazardous locations.**



### Important Safety Instructions

Read all warnings and instructions in this manual and in related manuals. Save these instructions.

### Part No. 24X011

*Maximum Working Pressure 1800 psi (12.4 MPa, 124 ba)*

### Related Manuals

Manual No.	Description
3A0420	XP <sup>TM</sup> and XP-h Proportioners

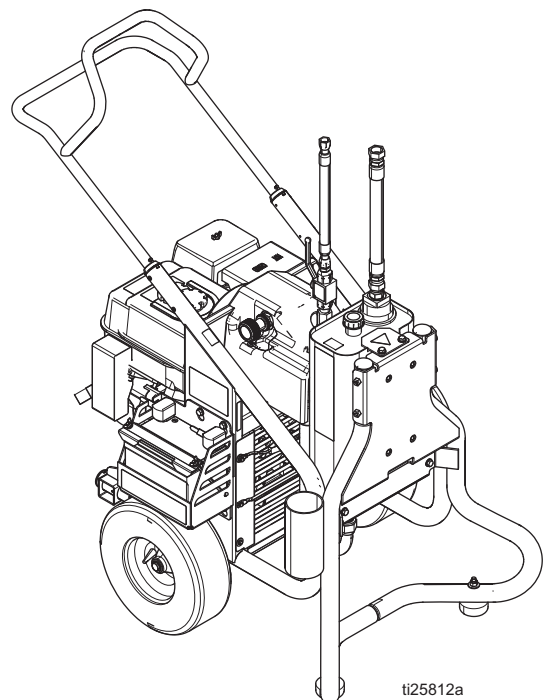

ti25812a







# Contents







<b>Warnings</b> .....	<b>3</b>	<b>Changing Hydraulic Oil Filter</b> .....	<b>25</b>
<b>Component Identification</b> .....	<b>6</b>	Removal .....	25
<b>Lift Instructions</b> .....	<b>7</b>	Installation .....	25
<b>Removing Handle</b> .....	<b>8</b>	<b>Cooler Replacement</b> .....	<b>26</b>
Fixed Mounting (optional) .....	8	Removal .....	26
Repositioning Handle .....	8	Installation .....	27
<b>Securing Unit to Vehicle Bed</b> .....	<b>9</b>	<b>Engine Replacement</b> .....	<b>28</b>
<b>Pressure Relief Procedure</b> .....	<b>10</b>	Removal .....	28
<b>Grounding</b> .....	<b>10</b>	Installation .....	28
<b>Setup</b> .....	<b>11</b>	Engine Replacement .....	29
<b>Startup</b> .....	<b>12</b>	<b>Battery Replacement</b> .....	<b>30</b>
<b>Spraying</b> .....	<b>13</b>	Removal .....	30
<b>Maintenance</b> .....	<b>14</b>	Installation .....	30
<b>Troubleshooting</b> .....	<b>15</b>	<b>Frame</b> .....	<b>32</b>
<b>Compensator Seal Replacement</b> .....	<b>16</b>	Frame Parts List .....	33
Removal .....	16	<b>Frame (continued)</b> .....	<b>34</b>
<b>Hydraulic Pump Replacement</b> .....	<b>17</b>	Frame (Continued) Parts List .....	35
Changing Hydraulic Oil .....	17	<b>Hydraulic Pump and Reservoir</b> .....	<b>36</b>
Removal .....	17	Hydraulic Pump and Reservoir Parts List .....	37
Installation .....	19	<b>Battery</b> .....	<b>38</b>
<b>Belt Removal and Installation</b> .....	<b>21</b>	Parts List .....	38
<b>Replacing Oil Reservoir</b> .....	<b>22</b>	<b>Technical Data</b> .....	<b>39</b>
Removal .....	22	<b>Graco Standard Warranty</b> .....	<b>40</b>
Installation .....	23		

# Warnings



The following warnings are for the setup, use, grounding, maintenance, and repair of this equipment. The exclamation point symbol alerts you to a general warning and the hazard symbols refer to procedure-specific risks. When these symbols appear in the body of this manual or on warning labels, refer back to these Warnings. Product-specific hazard symbols and warnings not covered in this section may appear throughout the body of this manual where applicable.

 <b>WARNING</b>	
	<p><b>FIRE AND EXPLOSION HAZARD</b></p> <p>Flammable fumes, such as solvent and paint fumes, in <b>work area</b> can ignite or explode. To help prevent fire and explosion:</p> <ul style="list-style-type: none"> <li>• Use equipment only in well ventilated area.</li> <li>• Do not fill fuel tank while engine is running or hot; shut off engine and let it cool. Fuel is flammable and can ignite or explode if spilled on hot surface.</li> <li>• Eliminate all ignition sources; such as pilot lights, cigarettes, portable electric lamps, and plastic drop cloths (potential static arc).</li> <li>• Keep work area free of debris, including solvent, rags and gasoline.</li> <li>• Do not plug or unplug power cords, or turn power or light switches on or off when flammable fumes are present.</li> <li>• Ground all equipment in the work area. See <b>Grounding</b> instructions.</li> <li>• Use only grounded hoses.</li> <li>• Hold gun firmly to side of grounded pail when triggering into pail. Do not use pail liners unless they are antistatic or conductive.</li> <li>• <b>Stop operation immediately</b> if static sparking occurs or you feel a shock. Do not use equipment until you identify and correct the problem.</li> <li>• Keep a working fire extinguisher in the work area.</li> </ul>
	<p><b>SKIN INJECTION HAZARD</b></p> <p>High-pressure fluid from gun, hose leaks, or ruptured components will pierce skin. This may look like just a cut, but it is a serious injury that can result in amputation. <b>Get immediate surgical treatment.</b></p> <ul style="list-style-type: none"> <li>• Do not spray without tip guard and trigger guard installed.</li> <li>• Engage trigger lock when not spraying.</li> <li>• Do not point gun at anyone or at any part of the body.</li> <li>• Do not put your hand over the spray tip.</li> <li>• Do not stop or deflect leaks with your hand, body, glove, or rag.</li> <li>• Follow the <b>Pressure Relief Procedure</b> when you stop spraying and before cleaning, checking, or servicing equipment.</li> <li>• Tighten all fluid connections before operating the equipment.</li> <li>• Check hoses and couplings daily. Replace worn or damaged parts immediately.</li> </ul>
	<p><b>MOVING PARTS HAZARD</b></p> <p>Moving parts can pinch, cut or amputate fingers and other body parts.</p> <ul style="list-style-type: none"> <li>• Keep clear of moving parts.</li> <li>• Do not operate equipment with protective guards or covers removed.</li> <li>• Pressurized equipment can start without warning. Before checking, moving, or servicing equipment, follow the <b>Pressure Relief Procedure</b> and disconnect all power sources.</li> </ul>

# ! WARNING

 	<p><b>ENTANGLEMENT HAZARD</b></p> <p>Rotating parts can cause serious injury.</p> <ul style="list-style-type: none"> <li>• Keep clear of moving parts.</li> <li>• Do not operate equipment with protective guards or covers removed.</li> <li>• Do not wear loose clothing, jewelry or long hair while operating equipment.</li> <li>• Equipment can start without warning. Before checking, moving, or servicing equipment, follow the <b>Pressure Relief Procedure</b> and disconnect all power sources.</li> </ul>
	<p><b>CARBON MONOXIDE HAZARD</b></p> <p>Exhaust contains poisonous carbon monoxide, which is colorless and odorless. Breathing carbon monoxide can cause death.</p> <ul style="list-style-type: none"> <li>• Do not operate in an enclosed area.</li> </ul>
	<p><b>TOXIC FLUID OR FUMES HAZARD</b></p> <p>Toxic fluids or fumes can cause serious injury or death if splashed in the eyes or on skin, inhaled, or swallowed.</p> <ul style="list-style-type: none"> <li>• Read MSDSs to know the specific hazards of the fluids you are using.</li> <li>• Store hazardous fluid in approved containers, and dispose of it according to applicable guidelines.</li> </ul>
	<p><b>BATTERY SAFETY</b></p> <p>The battery may leak, explode, cause burns, or cause an explosion if mishandled.</p> <ul style="list-style-type: none"> <li>• Only use the battery type specified for use with the equipment.</li> <li>• Battery maintenance must only be performed or supervised by personnel knowledgeable of batteries and the required precautions. Keep unauthorized personnel away from battery.</li> <li>• Do not dispose of battery in fire. The battery is capable of exploding.</li> <li>• Follow local ordinances and/or regulations for disposal.</li> <li>• Do not open or mutilate the battery. Released electrolyte has been known to be harmful to the skin and eyes and to be toxic.</li> <li>• Remove watches, rings, or other metal objects.</li> <li>• Only use tools with insulated handles. Do not lay tools or metal parts on top of battery.</li> </ul>
	<p><b>BURN HAZARD</b></p> <p>Equipment surfaces and fluids that are heated can become very hot during operation. To avoid severe burns:</p> <ul style="list-style-type: none"> <li>• Do not touch hot fluid or equipment.</li> </ul>

# ! WARNING

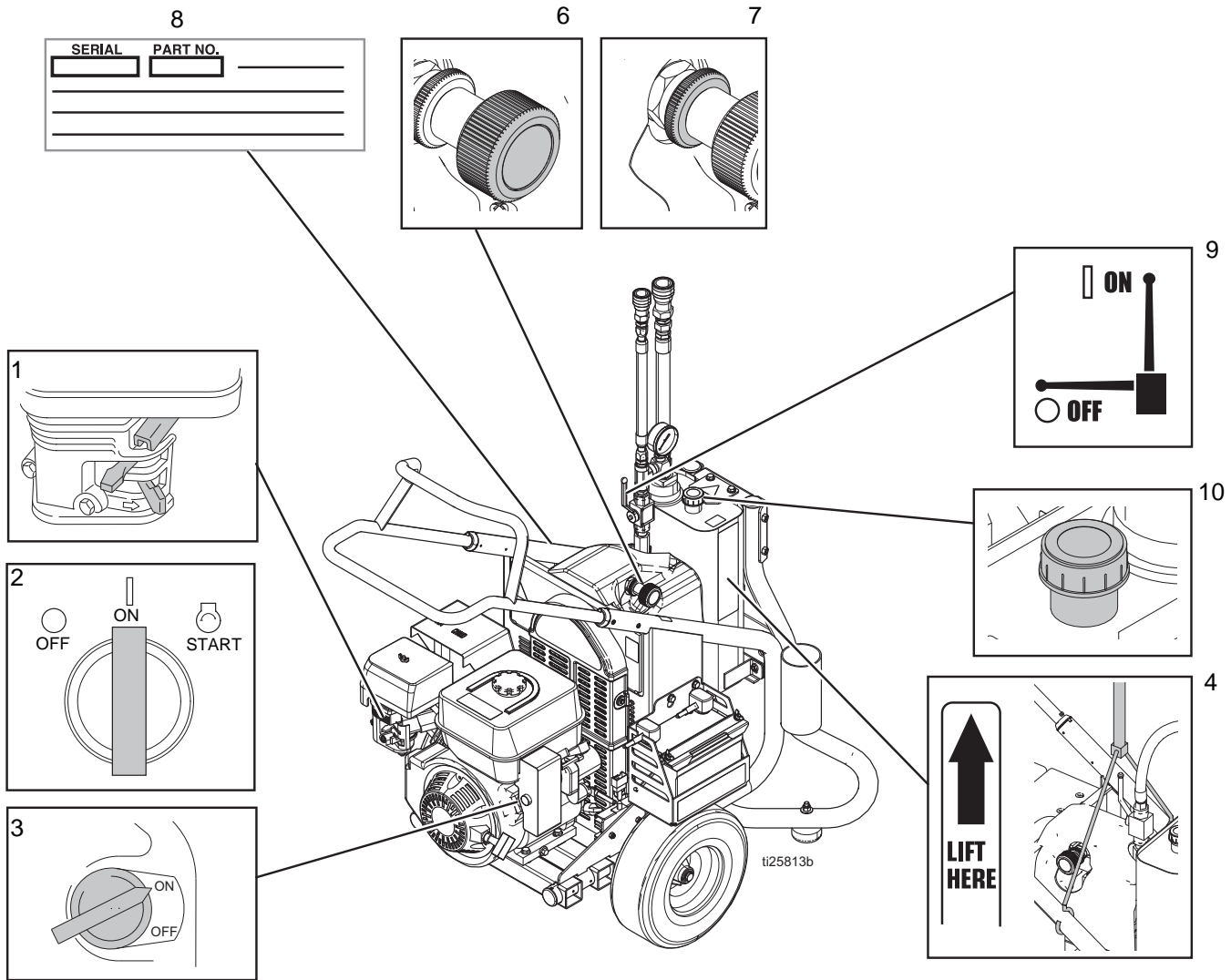

 	<p><b>EQUIPMENT MISUSE HAZARD</b></p> <p>Misuse can cause death or serious injury.</p> <ul style="list-style-type: none"> <li>• Do not operate the unit when fatigued or under the influence of drugs or alcohol.</li> <li>• Do not exceed the maximum working pressure or temperature rating of the lowest rated system component. See <b>Technical Data</b> in all equipment manuals.</li> <li>• Use fluids and solvents that are compatible with equipment wetted parts. See Technical Data in all equipment manuals. Read fluid and solvent manufacturer's warnings. For complete information about your material, request MSDS from distributor or retailer.</li> <li>• Do not leave the work area while equipment is energized or under pressure.</li> <li>• Turn off all equipment and follow the <b>Pressure Relief Procedure</b> when equipment is not in use.</li> <li>• Check equipment daily. Repair or replace worn or damaged parts immediately with genuine manufacturer's replacement parts only.</li> <li>• Do not alter or modify equipment. Alterations or modifications may void agency approvals and create safety hazards.</li> <li>• Make sure all equipment is rated and approved for the environment in which you are using it.</li> <li>• Use equipment only for its intended purpose. Call your distributor for information.</li> <li>• Route hoses and cables away from traffic areas, sharp edges, moving parts, and hot surfaces.</li> <li>• Do not kink or over bend hoses or use hoses to pull equipment.</li> <li>• Keep children and animals away from work area.</li> <li>• Comply with all applicable safety regulations.</li> </ul>
	<p><b>PERSONAL PROTECTIVE EQUIPMENT</b></p> <p>Wear appropriate protective equipment when in the work area to help prevent serious injury, including eye injury, hearing loss, inhalation of toxic fumes, and burns. Protective equipment includes but is not limited to:</p> <ul style="list-style-type: none"> <li>• Protective eyewear, and hearing protection.</li> <li>• Respirators, protective clothing, and gloves as recommended by the fluid and solvent manufacturer.</li> </ul>
	<p><b>CALIFORNIA PROPOSITION 65</b></p> <p>The engine exhaust from this product contains a chemical known to the State of California to cause cancer, birth defects or other reproductive harm.</p>

# Component Identification



1	Engine Controls
2	Engine ON/OFF Switch (Electric-Start Units)
3	Ignition
4	Lift Location
6	Pressure Control
7	Lock Ring
8	Serial Number ID Label
9	Hydraulic Pump Valve
10	Hydraulic Oil Fill

# Lift Instructions

						
<p>To avoid injury, always use designated Lift Locations when lifting the unit. Always use approved equipment for securing the unit to transporting equipment.</p>						

1. When lifting the power pack, balance weight evenly across two straps/chains as shown.

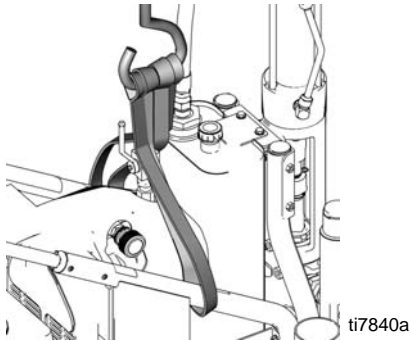

2. Wrap each strap/chain securely around frame where indicated on frame label as shown.

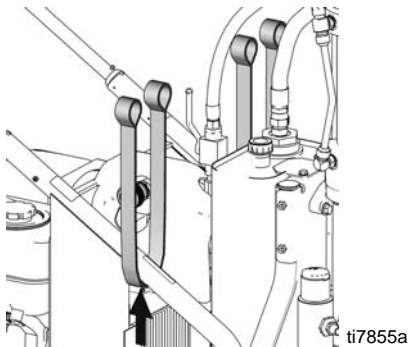

3. Be sure straps/chains used for lifting are rated to support weight of the power pack: 390 lbs (177 kg).

**NOTE:** Lift power pack and sprayer components separately. Disconnect fluid hoses.

<p><b>NOTICE</b></p> <p>Do not lift unit with only one strap secured across pump. This could put stress on frame and damage pump.</p>
---



# Removing Handle



## Fixed Mounting (optional)

To prevent damaging the unit when transporting it in a truck or on a trailer, Graco recommends fixed mounting to the vehicle.

## Repositioning Handle

Before you can secure the unit to a truck or trailer bed, you must reposition the handle.

1. Remove the 4 handle sleeve screws (143).

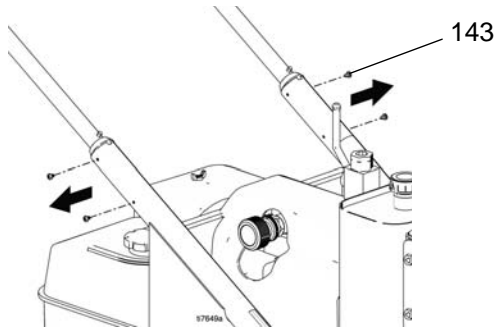

2. Remove handle assembly (25) by pulling it out of upper frame tubes (1).

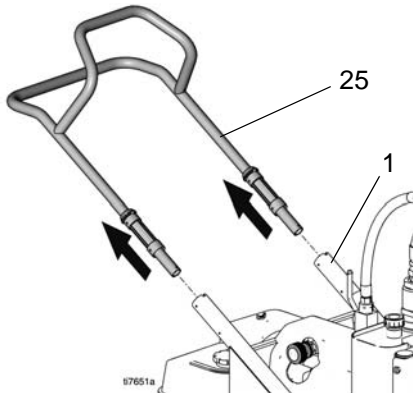

3. Remove frame tube plugs (120) located behind the wheels.

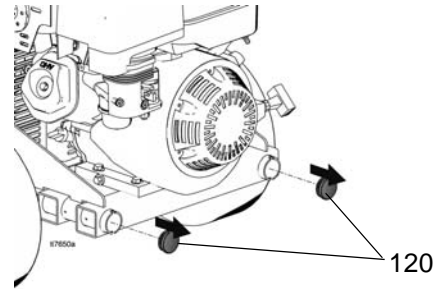

4. Insert plugs (120) in upper frame handle tubes (a).

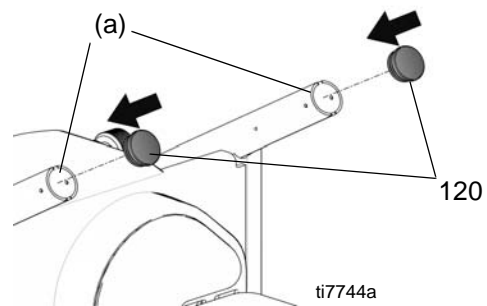

5. Insert handle assembly (25) into lower frame tubes (b). The hose bracket should face down. Adjust to appropriate in/out location.

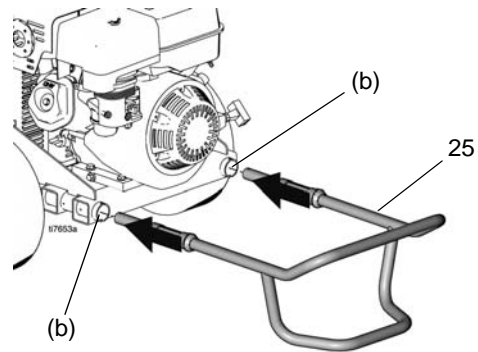

6. Install sleeve screws (143) in lower frame tubes.

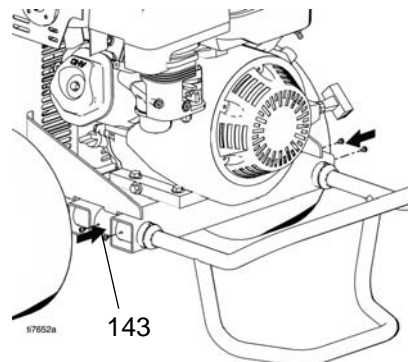



# Securing Unit to Vehicle Bed

For fixed mounting, fasten U-bolts over sprayer frame as indicated in the following illustration.

1. Reposition handle, steps 1-5, page 8.

2. Place U-bolts over sprayer frame and through holes in vehicle bed. Place a washer and nut over bolt end. Using a wrench, tighten nut securely.

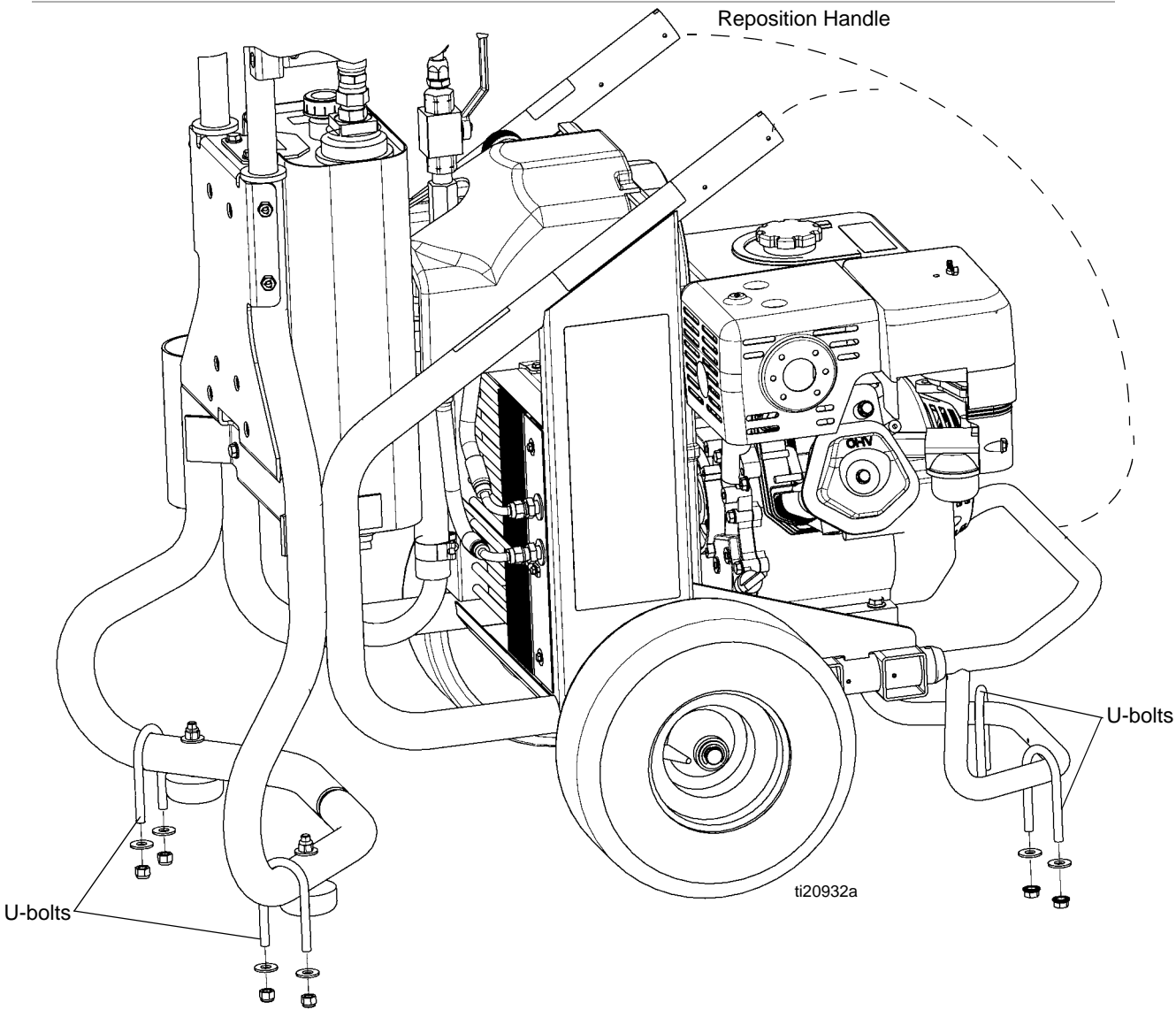

# Pressure Relief Procedure



Follow the Pressure Relief Procedure whenever you see this symbol.



This equipment stays pressurized until pressure is manually relieved. To help prevent serious injury from pressurized fluid, such as skin injection, splashing fluid and moving parts, follow the Pressure Relief Procedure when you stop spraying and before cleaning, checking, or servicing the equipment.

1. Set pump valve OFF.

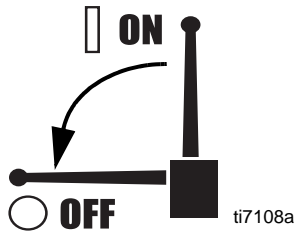

2. Turn engine OFF.

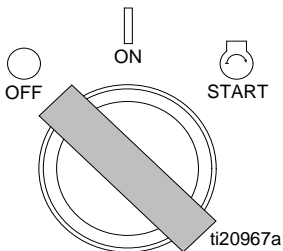

3. Loosen Lock Ring. Turn pressure control to lowest setting.

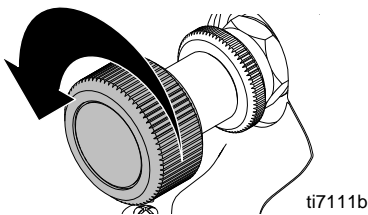

4. Trigger gun into pail to relieve pressure.
5. See XP-h manual 3A0420 for the **Pressure Relief Procedure** of the XP-h proportioner.

# Grounding



The equipment must be grounded to reduce the risk of static sparking. Static sparking can cause fumes to ignite or explode. Grounding provides an escape wire for the electric current.

Use ground wire and clamp (supplied). Loosen ground ing lug locknut (W) and washer (X). Insert ground wire end (Y) into lug (Z) slot and tighten locknut securely. Connect ground clamp to a true earth ground.

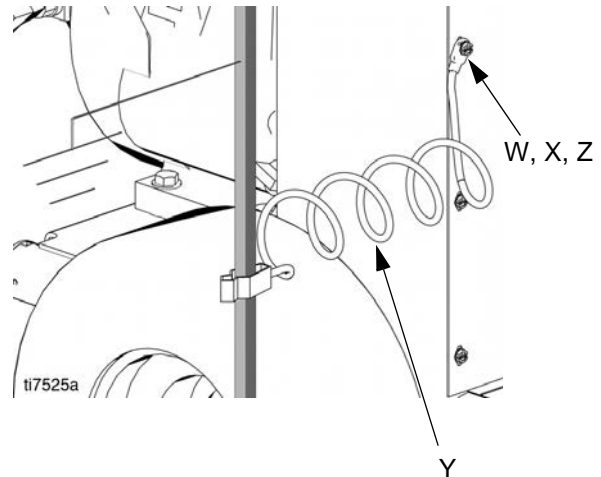

# Setup



1. Follow **Setup** instructions in the XP-h Proportioner manual.
2. Check engine oil level. Add SAE 10W-30 (summer) or 5W-20 (winter), if necessary.

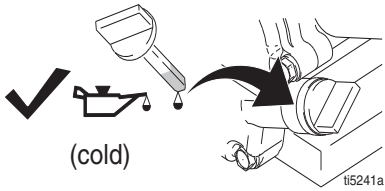

3. Fill engine fuel tank.

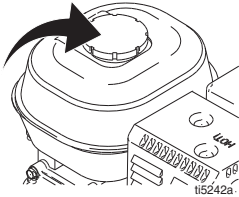

4. Remove the hydraulic oil fill cap (27) and check the hydraulic reservoir oil level. Add only Graco Hydraulic Oil, ISO 46 169236 (5 gallon/18.9 liter) or 207428 (1 gallon/3.8 liter). Hydraulic reservoir capacity is approximately 4.0 gallons (15.14 liters).

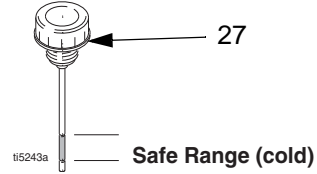

5. Verify all hose/fitting connections from the power pack and XP-h Proportioner are tight.

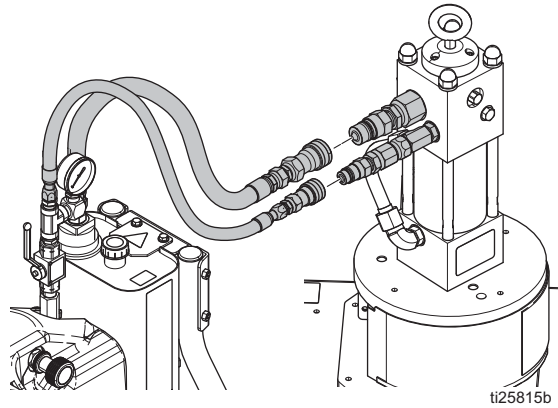

Attach XP-h Proportioner grounding clamp to earth ground to reduce the risk of static sparking. See XP Proportioner manual for instructions.						

# Startup



Hydraulic system and engine may become very hot during operation and could burn skin if touched. Flammable materials spilled on hot, bare motor could cause fire or explosion. Have belt guard in place during operation to reduce risk of entanglement or loss of fingers.

1. Loosen lock nut and turn pressure control counter clockwise to lowest pressure.

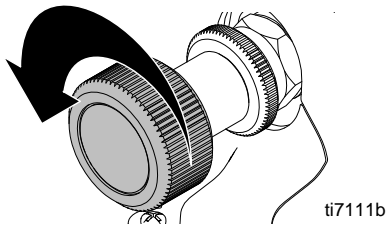

2. Set pump valve OFF.

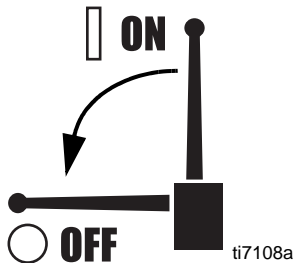

3. Start engine.

- a. Move fuel valve to open.

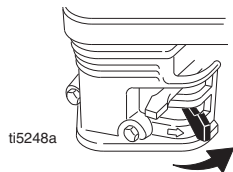

- b. Move choke to closed.

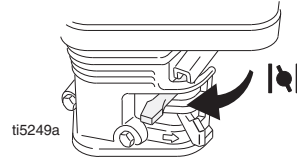

- c. Set throttle to fast.

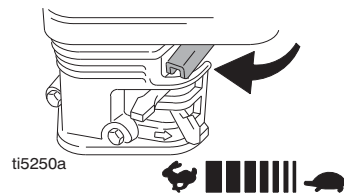

- d. Rotate key to start.

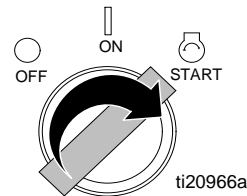

- e. After engine starts, move choke to open.

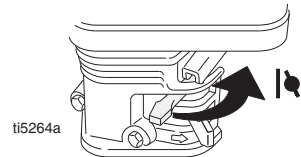

- f. Set throttle to desired setting.



# Spraying



1. Set pump valve ON.

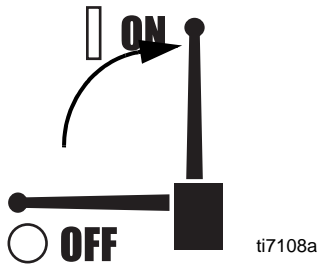

2. Increase pressure enough to start hydraulic motor stroking and allow fluid to circulate for 15 seconds; turn pressure down.

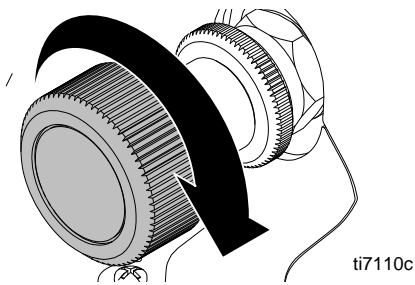

3. Turn spray gun trigger safety OFF.

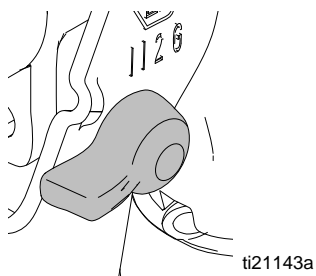

4. Adjust pressure to desired setting. Begin spraying.

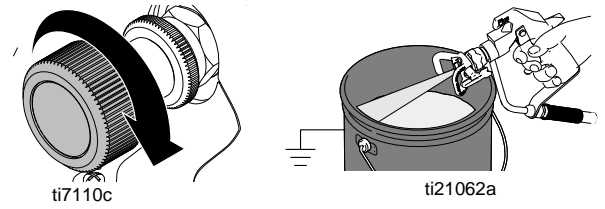

5. Rotate Lock Ring clockwise to set pressure.

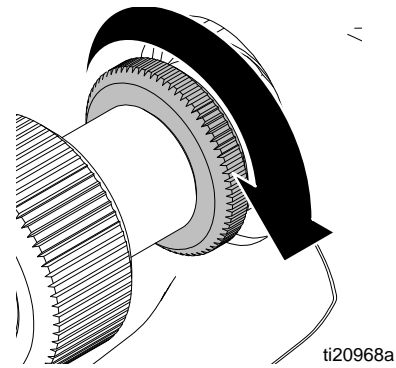

# Maintenance



For detailed engine maintenance and specifications, refer to separate Honda Engines Owner's Manual, supplied.

### Spark Plug:

- Use BPR6ES (NGK) or W20EPR-U (NIPPONDENSO) plug, only.
- Gap plug to 0.028 to 0.031 in. (0.7 to 0.8 mm).
- Use spark plug wrench when installing and removing plug.

Frequency	Procedure
Daily	Check engine oil level and fill as necessary.
Daily	Check hydraulic oil level and fill as necessary.
Daily	Check hose for wear and damage.
Daily	Check gun safety for proper operation.
Daily	Check pressure drain valve for proper operation.
Daily	Check and fill gas tank.
After first 20 hours of operation	Drain engine oil and refill with clean oil. Reference Honda Engines Owner's Manual for correct oil viscosity.
Weekly	Remove engine air filter cover and clean element. Replace element, if necessary. If operating in an unusually dusty environment; check filter daily and replace, if necessary. Replacement elements can be purchased from your local Honda dealer.
Weekly/Daily	Remove and debris or media from hydraulic rod.
After each 100 hours of operation	Change engine oil. Reference Honda Engines Owner's Manual for correct oil viscosity.
Semi-annually	Check belt wear; replace if necessary.
Yearly or 2000 hours	Replace hydraulic oil and filter element with Graco ISO 46 Hydraulic Oil 169236; 5 gallon/20 liter or 207428; 1 gallon/3.8 liter) and filter element 287871.

# Troubleshooting



PROBLEM	CAUSE	SOLUTION
Gas engine pulls hard (will not start).	Hydraulic pressure is too high.	Turn hydraulic pressure knob counterclockwise to lowest setting.
Gas engine does not start.	Switch OFF, low oil, no gasoline or dead battery.	Consult engine manual, supplied. Change battery if necessary.
Gas engine doesn't work properly.	Faulty engine.	Consult engine manual, supplied.
Gas engine operates, but displacement pump doesn't operate.	Pump valve is OFF.	Set pump valve ON.
	Pressure setting too low.	Increase pressure.
	Tip or tip filter (if used) is clogged.	Remove tip and/or filter and clean.
	Hydraulic fluid too low.	Shut off sprayer. Add fluid*.
	Belt worn, broken or off.	Replace belt.
	Hydraulic pump worn or damaged.	Bring sprayer to Graco distributor for repair.
Excessive leakage around hydraulic motor piston rod wiper.	Hydraulic motor not shifting.	Set pump valve OFF. Turn pressure down. Turn engine OFF. Pry rod up or down until hydraulic motor shifts.
	Piston rod seal worn or damaged.	Replace these parts.
Fluid delivery is low.	Pressure setting too low.	Increase pressure.
	Displacement pump outlet filter (if used) is dirty or clogged.	Clean filter.
	Intake line to pump inlet is not tight.	Tighten.
	Hydraulic motor is worn or damaged.	Bring sprayer to Graco distributor for repair.
	Large pressure drop in fluid hose.	Use larger diameter or shorter hose.
The sprayer overheats.	Paint buildup on hydraulic components.	Clean hydraulic components.
	Oil level is low.	Fill with oil.
Excessive hydraulic pump noise.	Low hydraulic fluid level.	Turn sprayer OFF. Add fluid*.

\*Check hydraulic fluid level often. Do not allow it to become too low. Use only Graco approved hydraulic fluid, page 25.

# Compensator Seal Replacement

## Removal

Allow hydraulic system to cool before beginning the service procedure to prevent injury.					

1. Perform **Pressure Relief Procedure**, page 10.
2. Remove screw (197) and pump handle cover (196). Remove four cover bolts (79) and cover (140).

**NOTE:** It is not necessary to remove the hydraulic lines before removing the cover. The cover is designed to provide ample room for the cover to fit over the hose.

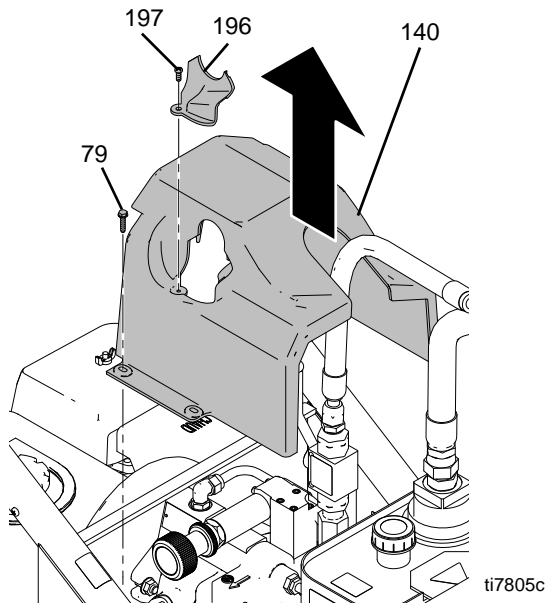

3. Remove compensator screws and separate compensator and adapter block.

4. Install new gaskets and torque screws.

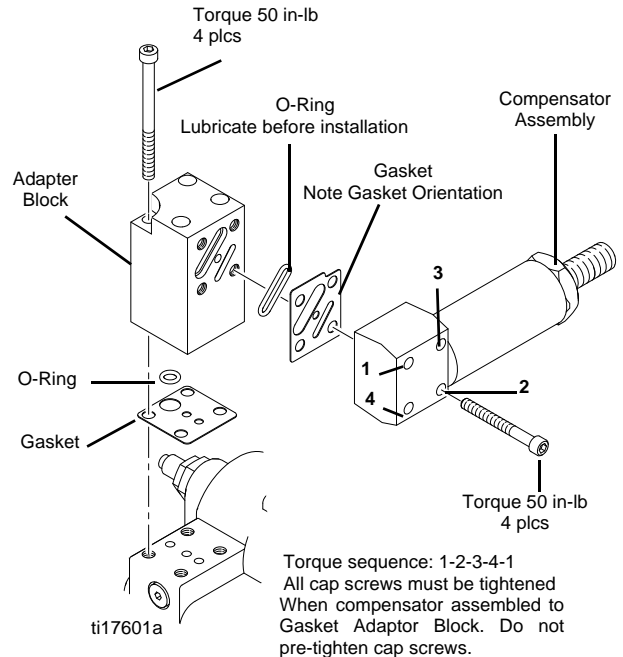

5. Install cover (140) with four screws (79). Torque to 25-30 in-lb (2.8 - 3.4 N•m). Install pump handle cover (196) with screw (197).

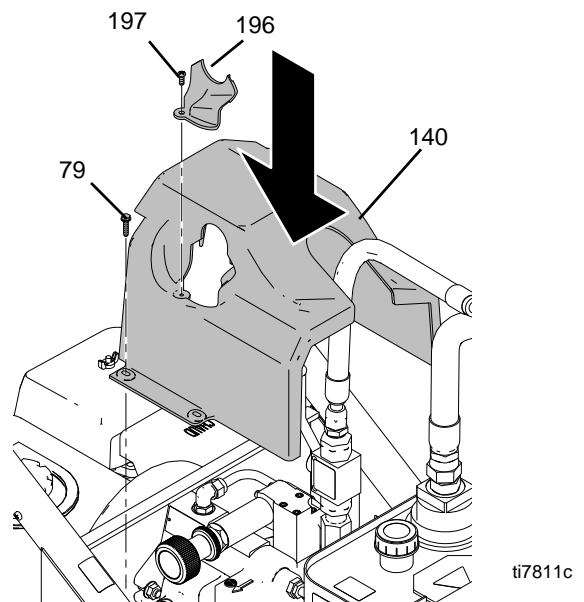



# Hydraulic Pump Replacement

## Changing Hydraulic Oil

<b>NOTICE</b>	
To prevent damage to the hydraulic pump, only use hydraulic fluid.	

### Draining Oil

- a. Place drain pan under oil reservoir and drain plug.
- b. Unscrew reservoir (64) drain plug and drain oil from reservoir.

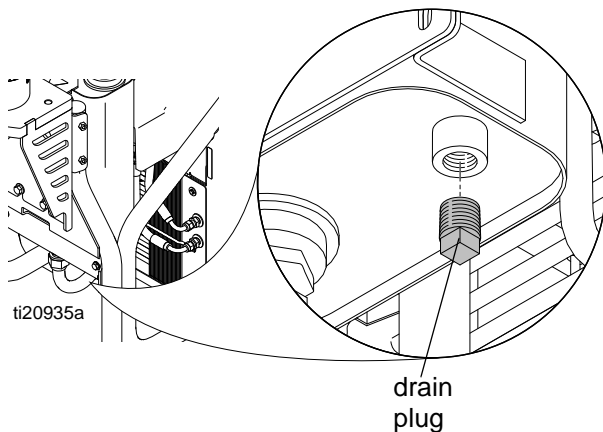

### Refilling Oil

- a. Replace drain plug.
- b. Fill tank with Graco Hydraulic Oil, ISO 46. Reservoir holds approximately 4 gallons (15.14 liters).

### Removal

						
Allow hydraulic system to cool before beginning the service procedure to prevent injury.						

1. Perform **Pressure Relief Procedure**, page 10.
2. Drain oil, **Changing Hydraulic Oil** procedure, page 17.
3. Remove screw (197) and pump handle cover (196). Remove four cover bolts (79) and cover (140). (It is not necessary to remove the hydraulic lines before removing cover. The cover is designed to provide ample room for the cover to fit over the hose.)

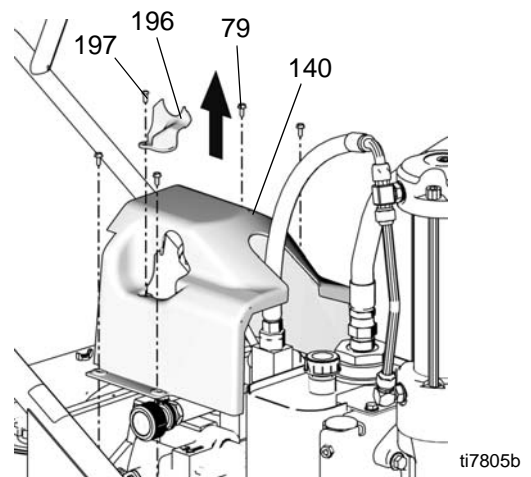

4. Unscrew suction line connections to hydraulic pump. Place a container under hoses to catch any dripping oil.

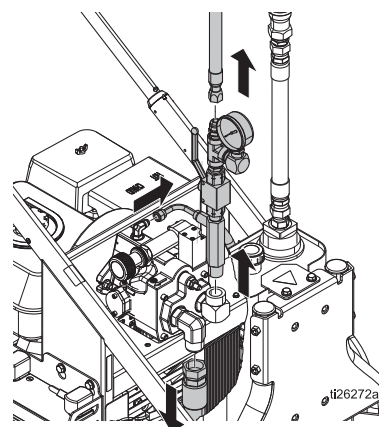

## Hydraulic Pump Replacement

5. Remove belt cover screws (79), washers (78) and grommets (80) (2 each side).

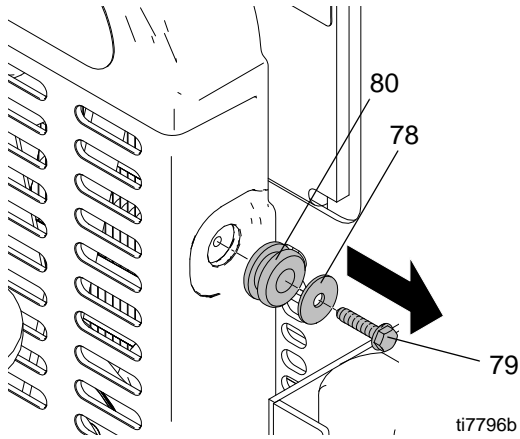

6. Remove belt cover (67).

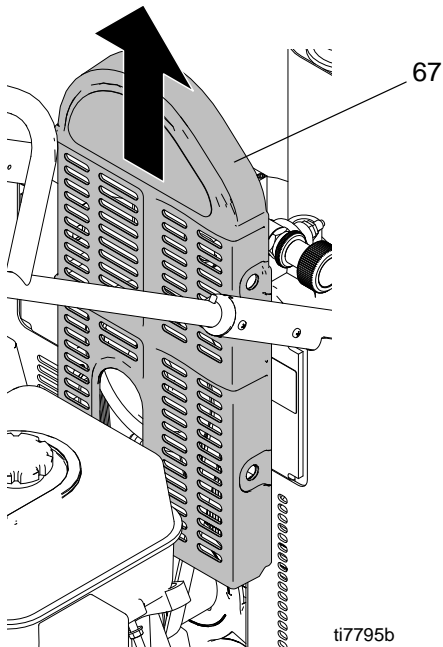

7. Remove belt (19), page 21.

8. Loosen set-screws (87) on front of large pulley (4).

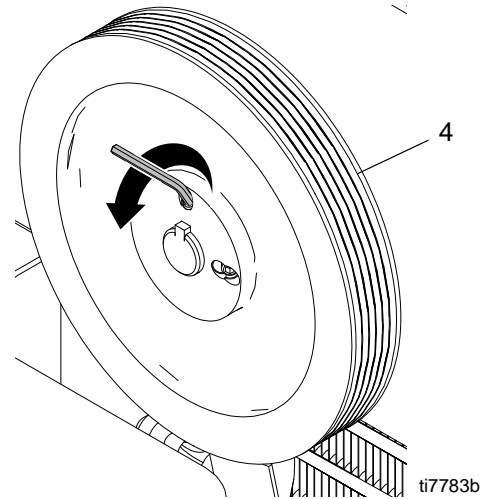

9. Remove pulley (4) from hydraulic pump shaft.

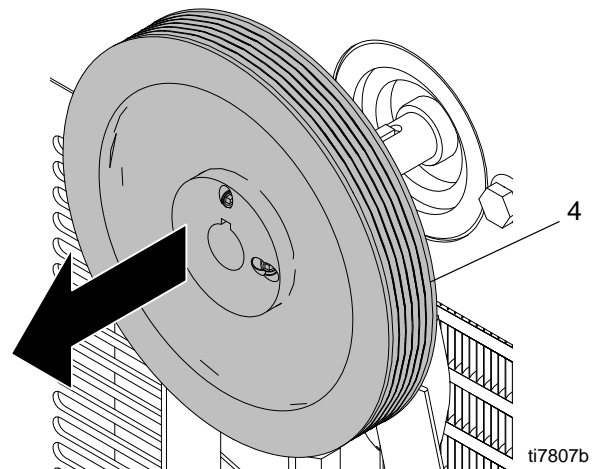

10. Remove nuts (10) and screws (9) holding pump to frame.

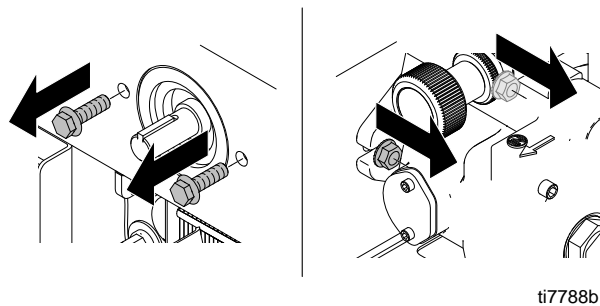

11. Remove hydraulic pump (3).

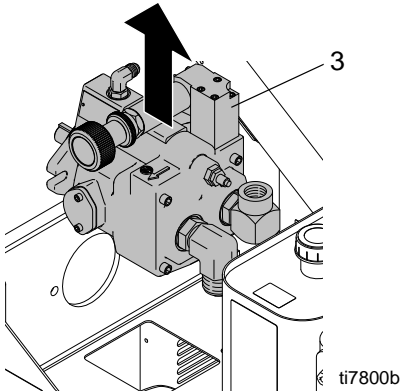

12. Remove fittings (30, 34, 35) from pump (3) and set aside to use on the new pump.

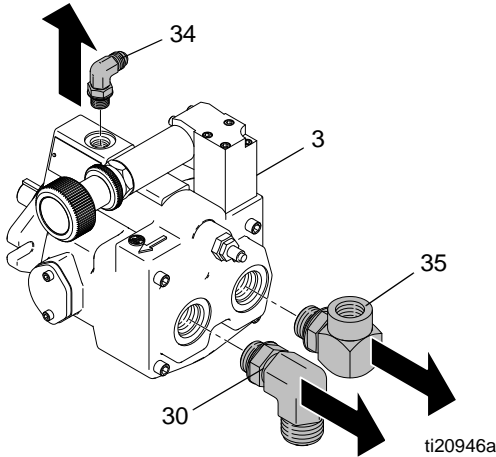

**Installation**

1. Install fittings (30, 34, 35) from old pump on new pump. Torque fitting (30) and (35) to  $600 \pm 10$  in-lb ( $67.8 \text{ N}\cdot\text{m}$ ). Torque fitting (34) to  $450$  in-lb ( $50.8 \text{ N}\cdot\text{m}$ ).

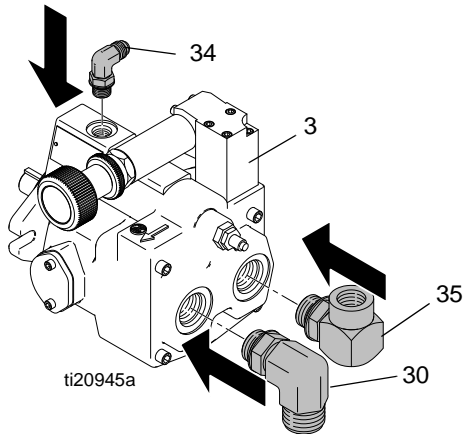

**NOTE:** Fill pump casing with hydraulic oil before installing fitting (34).

2. Install new pump (3) in frame.

3. Install screws (9) and nuts (10). Torque to  $225 \pm 10$  in-lb ( $25.42 \text{ N}\cdot\text{m}$ ).

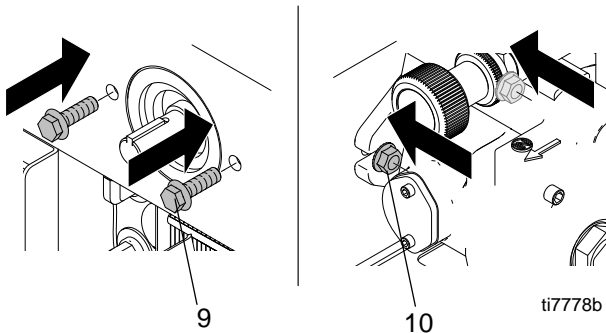

4. Replace large pulley (4) on hydraulic pump shaft.

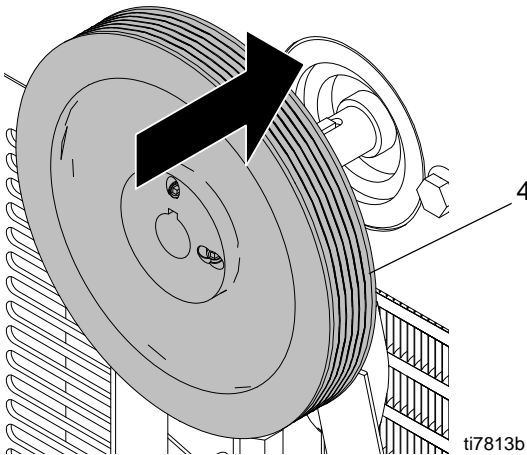

5. Align pulley (4) on shaft. When properly positioned approximately 1/8 inch of shaft (139) will protrude.

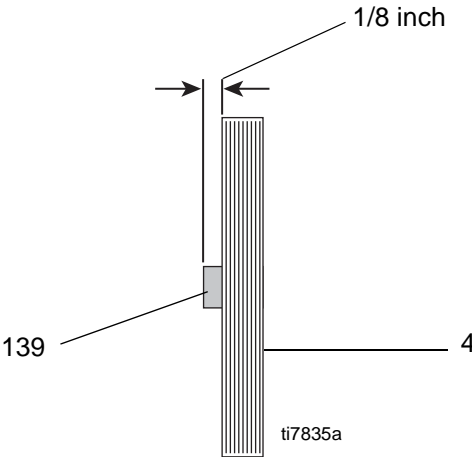

## Hydraulic Pump Replacement

6. Replace set-screws (87). Tighten and torque to  $60 \pm 2$  in-lb ( $6.8 \pm 0.2$  N•m).

**NOTE:** Tighten set-screw on shaft before tightening set-screw on pump shaft.

7. Position belt (19) over pulleys (4, 6); Installing Belt, page 21.
8. Replace belt cover (67) and grommets (80), washers (78) and screws (79), (2 each side). Torque screws to 25-30 in-lb ( $2.8 - 3.4$  N•m).

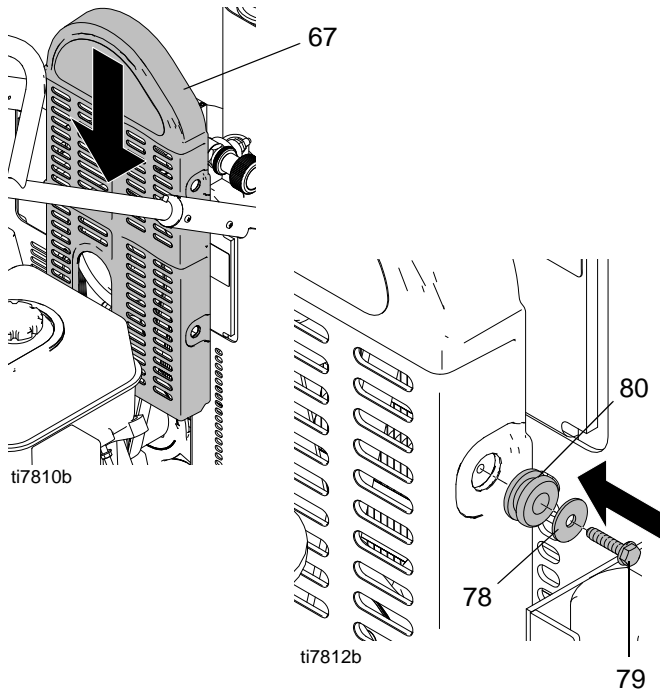

9. Install suction lines. Tighten fittings. Torque fitting A to  $225 \pm 10$  in-lb ( $25.4 \pm 1.1$  N•m). Fitting B to  $450 \pm 10$  in-lb ( $50.1 \pm 1.1$  N•m). Fitting C to 225 in-lb ( $25.4$  N•m).

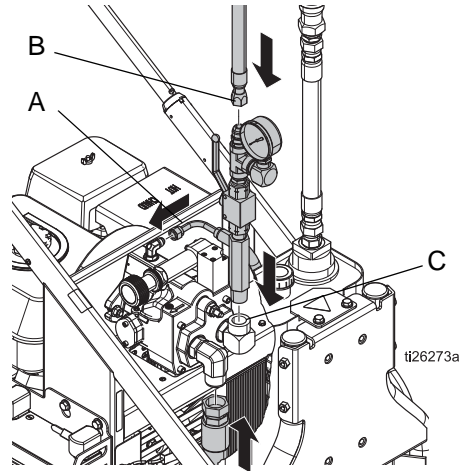

10. Install cover (140) and with four screws (79). Torque to 25-30 in-lb ( $2.8 - 3.4$  N•m). Install pump handle cover (196) with screw (197).

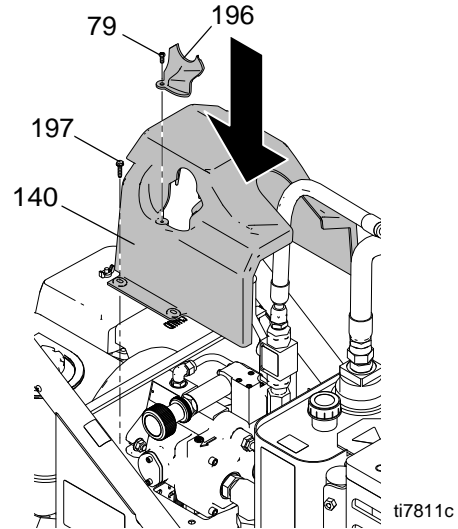

11. Fill oil tank following Refilling Oil procedure on page 17.

# Belt Removal and Installation

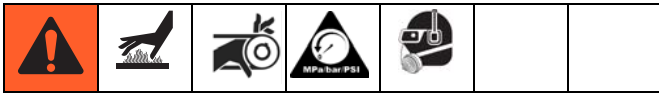

1. Perform **Pressure Relief Procedure**, page 10.

## Removing Belt

- a. Loosen engine bolts (21) to relieve tension on belt.
- b. Slide belt off pulleys.

## Installing Belt

- a. Install belt (19) over small (6) and large (4) pulleys.
- b. Tighten engine bolts (21). Torque to  $225 \pm 10$  in-lb ( $25.4 \pm 1.1$  N•m).
- c. Check belt (19) alignment on both large (4) and small pulley (6). When properly positioned over pulleys, belt should be centered on pulleys and completely over all grooves.

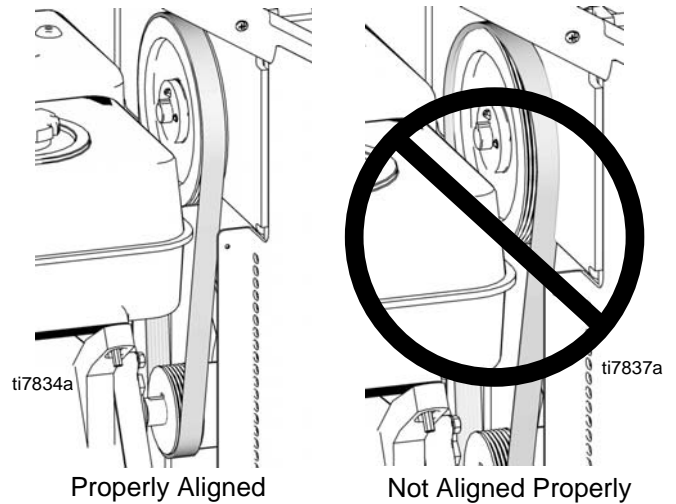

**NOTE:** If belt is not aligned properly, to adjust belt, slowly pull engine recoil while at the same time pushing or pull ing belt to reposition over pulley.

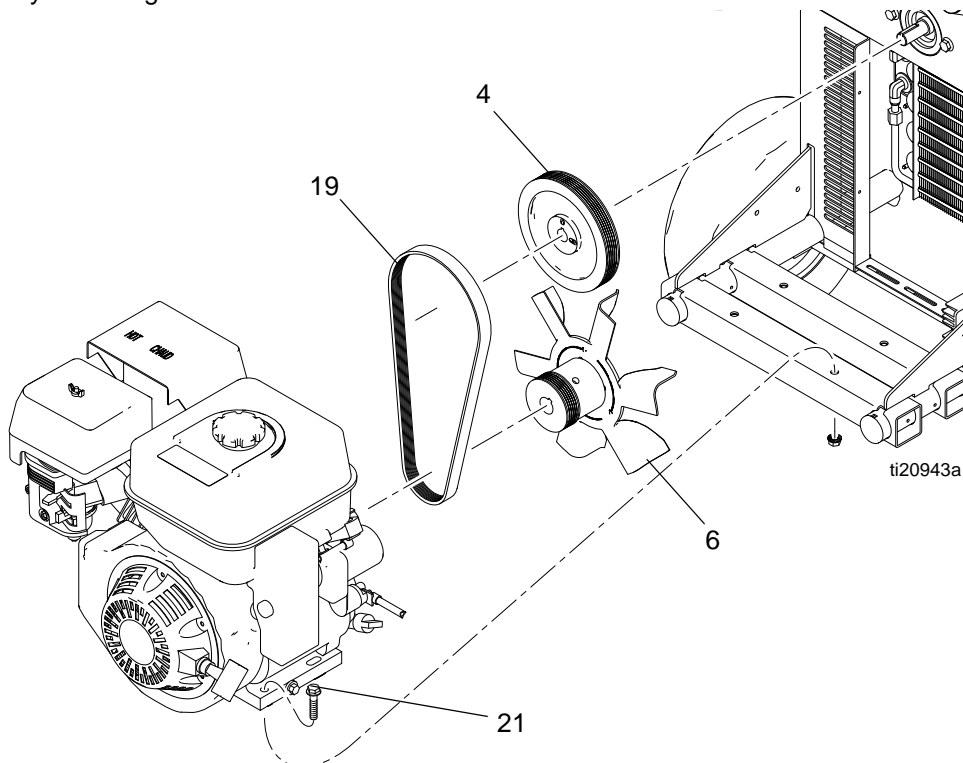

# Replacing Oil Reservoir

## Removal



1. Perform **Pressure Relieve Procedure**, page 10.
2. Drain oil from reservoir (64) following Draining Oil procedure, page 17. Keep plug for use on new reservoir.

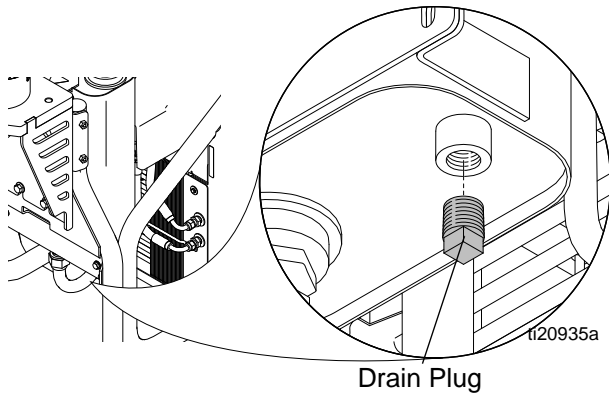

3. Remove fill cap (27) and filter assembly (111). Keep for use on new reservoir.

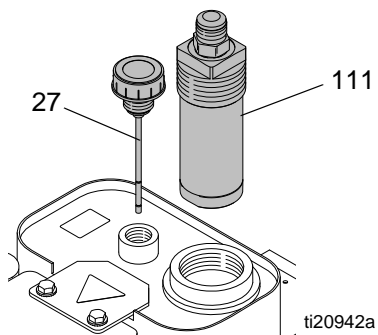

4. Loosen and remove suction hose (153).

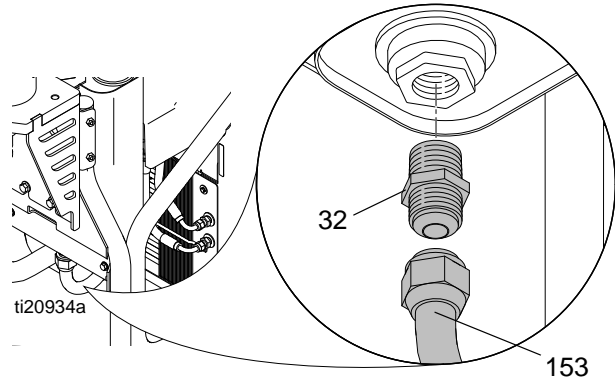

5. Remove and keep suction fitting (32) for use on new reservoir.
6. Disconnect hydraulic lines from the hydraulic pump.

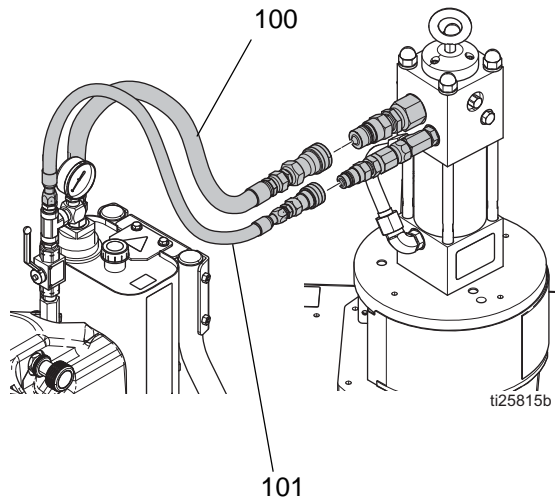

7. Remove cooler line from reservoir (64).

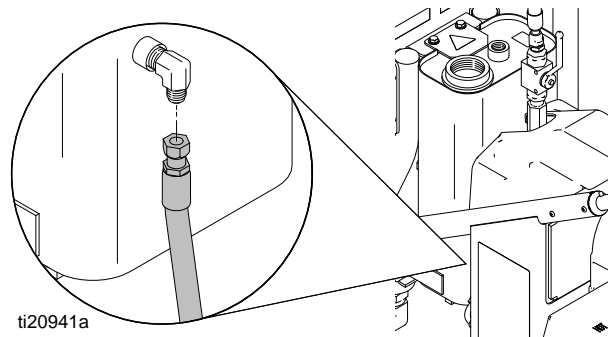

- Remove two top bolts (86) and two bottom nuts (84) securing reservoir (64) to frame.

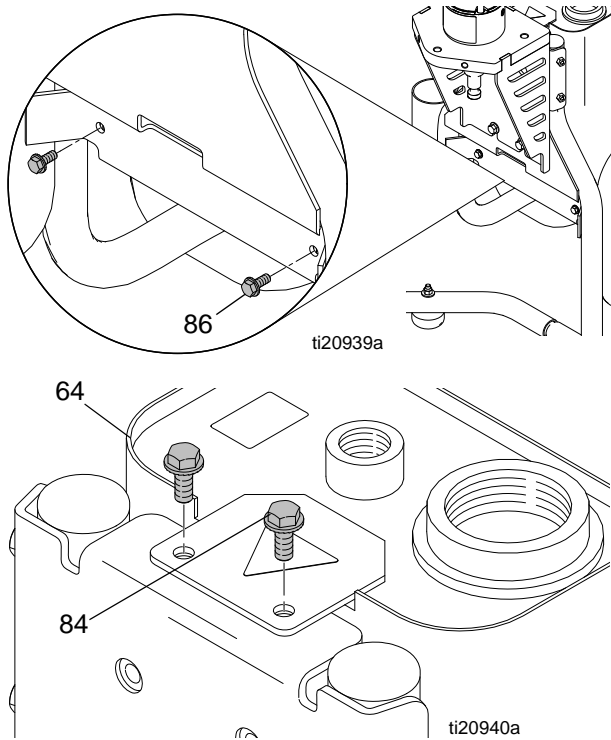

- Lift reservoir (64) out of frame.

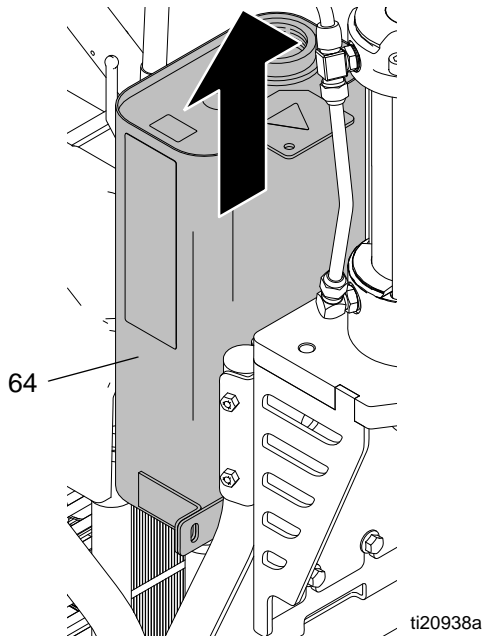

## Installation

- Install plug (102), return elbow (31), suction fitting (32), inlet screen (89) and filter assembly (111) in new reservoir (64).

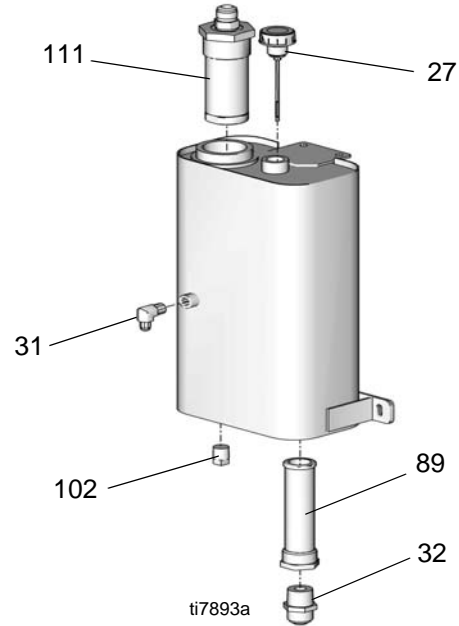

- Install new reservoir (64) in frame.

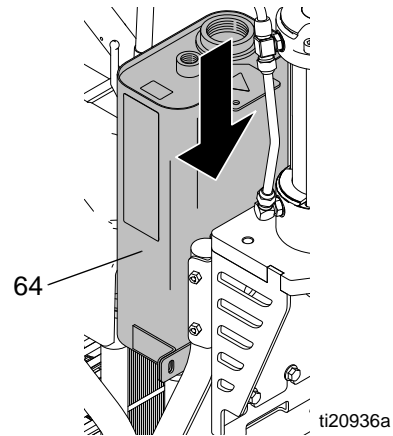

## Replacing Oil Reservoir

3. Replace bolts (86) and nuts (84). Tighten bolts. Torque to  $125 \pm 10$  in-lb ( $14 \pm 1.1$  N•m).
4. Connect coolant line to reservoir (64). Torque to 225 in-lb ( $14.1$  N•m).

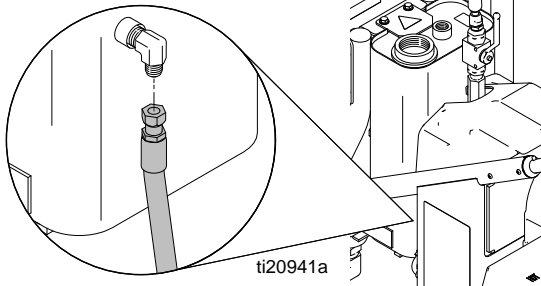

5. Reattach fluid lines (100, 101). Ensure fittings are connected securely.

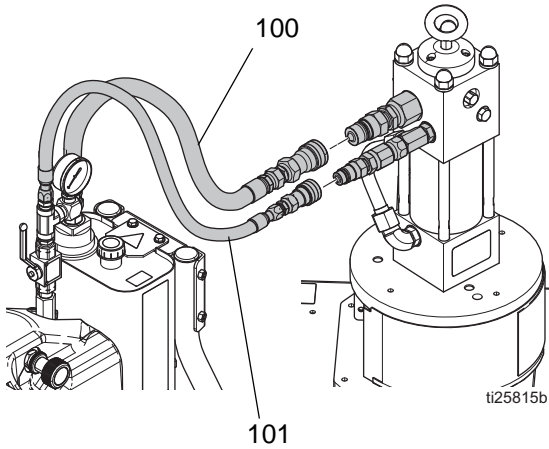

6. Install filter (107).

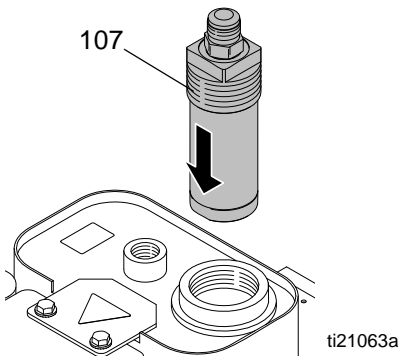

7. Reattach suction hose (153). Torque to  $600 \pm 10$  in-lb ( $68 \pm 1.1$  N•m).

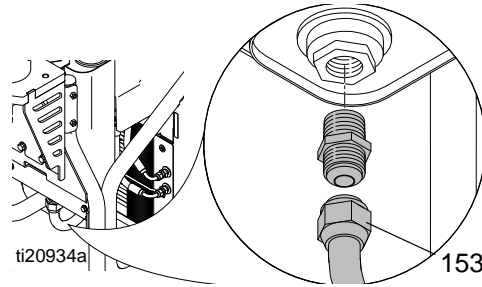

8. Verify drain plug has been replaced. Fill oil reservoir with oil to high mark on dip stick (approximately 3.5 gallons).

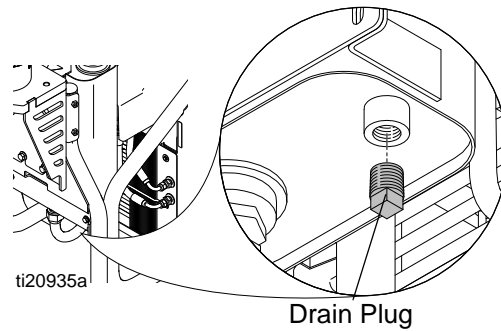

9. Replace cap (27).

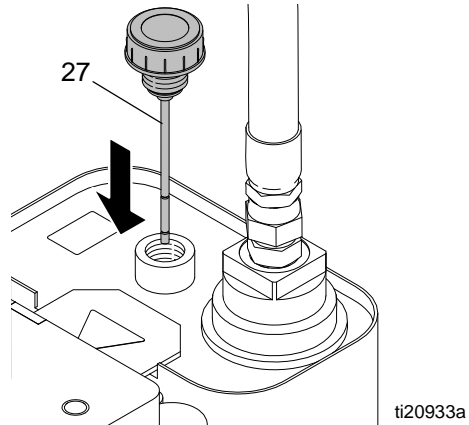



# Changing Hydraulic Oil Filter

## Removal



1. Perform **Pressure Relieve Procedure**, page 10.
2. Loosen and remove hose (101) from fitting (103).
3. Remove filter housing (111) from reservoir (64).
4. Remove bottom filter cap (155) from housing (111).
5. Pull filter (108) off cap (155).

## Installation

1. Install new o-ring (113) from kit.
2. Install new filter (108) over cap (155).
3. Install cap (155) and filter (108) in filter housing (111). Hand tighten cap till snug. Then torque to  $375 \pm 10$  in-lb ( $42 \pm 1.1$  N•m).
4. Install filter housing (111) into reservoir.
5. Install fitting (103) in filter housing (111). Torque to  $600 \pm 10$  in-lb ( $67.8 \pm 1.1$  N•m).
6. Reattach hose (101) to fitting (103). Torque to  $450 \pm 10$  in-lb ( $51 \pm 1.1$  N•m).

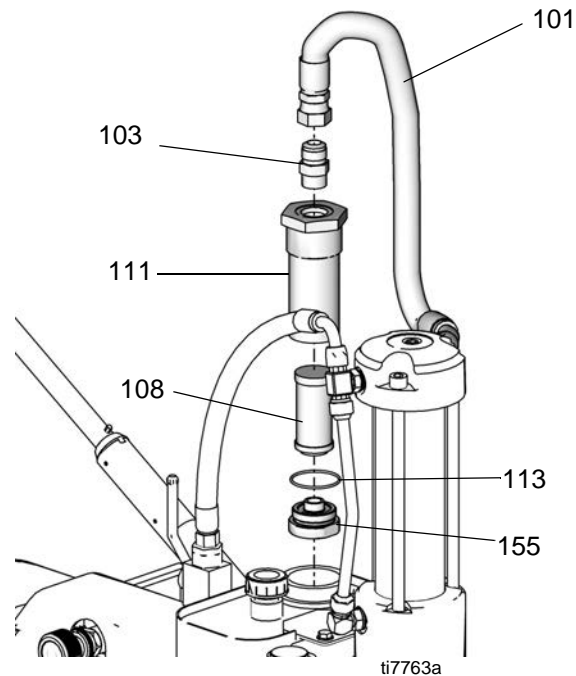

# Cooler Replacement



## Removal

1. Perform **Pressure Relieve Procedure**, page 10.
2. Loosen ground screw and remove ground clamp (95) from sprayer.

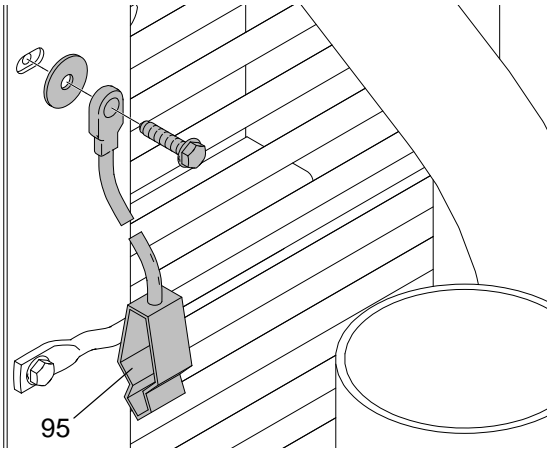

ti7799b

3. Loosen and remove return line to oil tank and hydraulic line to cooler.

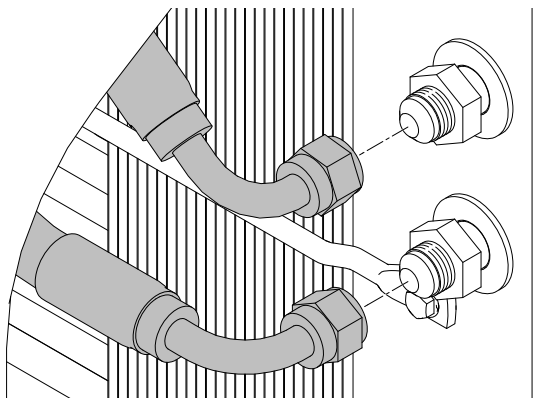

ti7802b

4. Remove screws (79), washers (78) and support bar (77) from cooling coil (72).

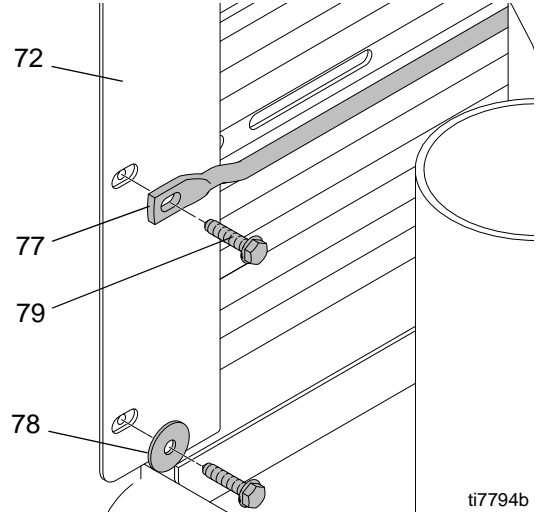

ti7794b

5. Remove coil (72) from sprayer frame.

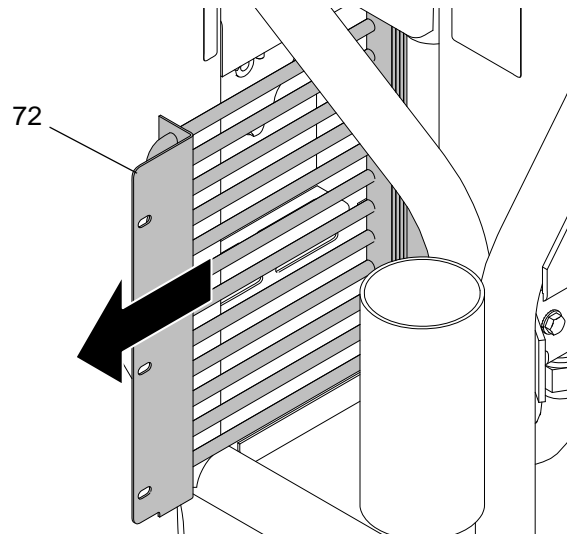

ti7792b

## Installation

1. Install new coil (72). Replace support bar (77), washers (78) and screws (79). Tighten screws.

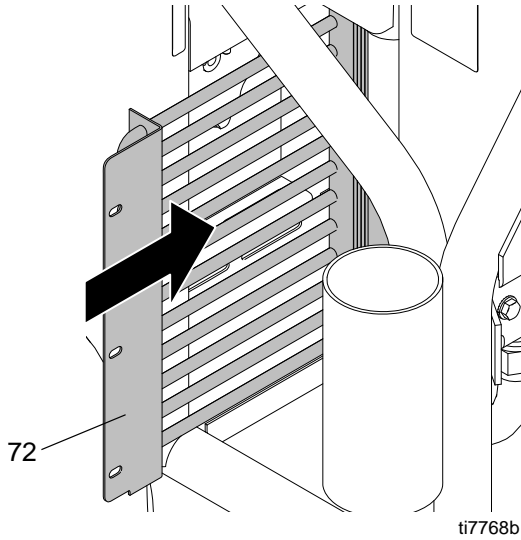

2. Replace bar and screws. Torque to 25-30 in-lb (2.8-3.4 N•m).

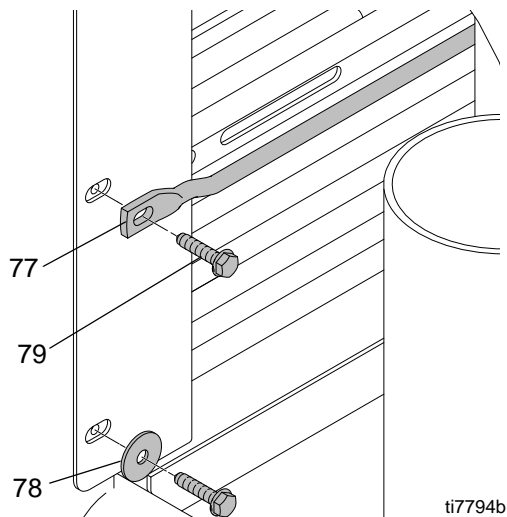

3. Reconnect return line to oil tank and hydraulic line to cooler. Torque to 225 in-lb (25.4 N•m).

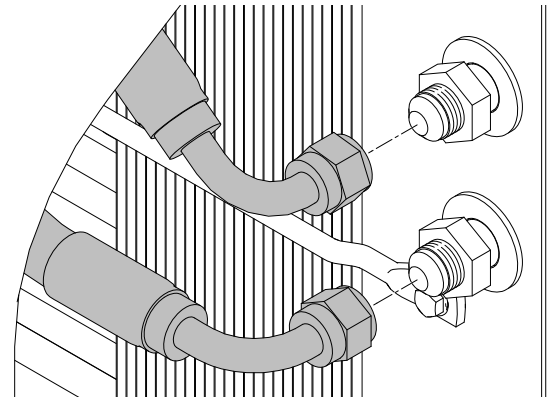

4. Replace ground wire (95) and tighten screw. Torque to 25-30 in-lb (2.8 - 3.4 N•m).

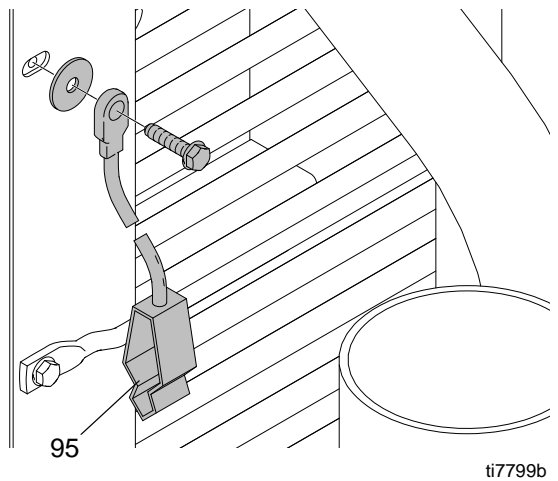

# Engine Replacement



## Removal

1. Perform **Pressure Relieve Procedure**, page 10.
2. Remove screws (79) and washers (78) and belt cover (67). See FIG. 1, page 29.
3. Remove belt (19), page 21.
4. Remove screws (21), washers (70) and nuts (10) securing motor (5) to frame.
5. Disconnect battery cables and voltage regulator.

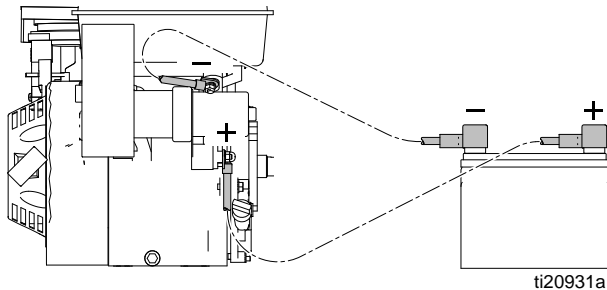

6. Remove motor (5) from frame.

## Replacing Motor Fan

### Removal

- a. Loosen and remove bolts (86) on front of fan (14).
- b. Pull fan (14) off small pulley (6).

### Installation

- a. Position new fan (14) over small pulley (6).
- b. Replace bolts (86) and tighten securely. Torque to  $125 \pm 10$  in-lb ( $14.1 \pm 1.1$  N•m).

## Removing Pulley

**NOTE:** This procedure is only necessary if you are replacing the motor. When you install a new motor you reuse the existing pulley.

### Removal

- a. Loosen set screw (87) located on the side of the pulley (6).
- b. Remove large bolt (24) in the center of pulley (6).
- c. Pull pulley (6) off motor (5).

### Installation

- a. Position new pulley (6) on motor (5).
- b. Install large bolt (24) and washer (65) in center of pulley (6). Torque to  $125 \pm 10$  in-lb ( $14.1 \pm 1.1$  N•m).
- c. Tighten set screw (87). Torque to  $60 \pm 2$  in-lb ( $25.4$  N•m).

## Installation

1. Install motor (5) in frame.
2. Reconnect battery cables and voltage regulator connection.

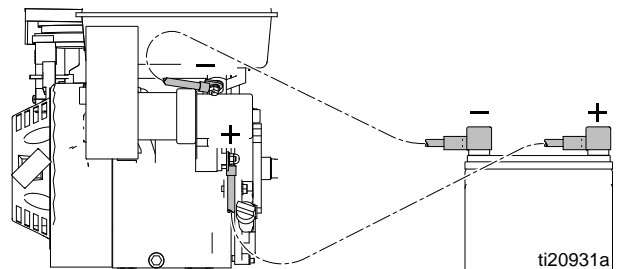

3. Replace all screws (21), washers (70) and nuts (10). Tighten securely.
4. Install belt (19) over pulleys (4, 6), page 21.
5. Replace belt cover (67) and screws (79) and washers (78) (2 each side). Using a wrench tighten bolts. Torque to 25-30 in-lb ( $2.8$ - $3.4$  N•m).

# Engine Replacement

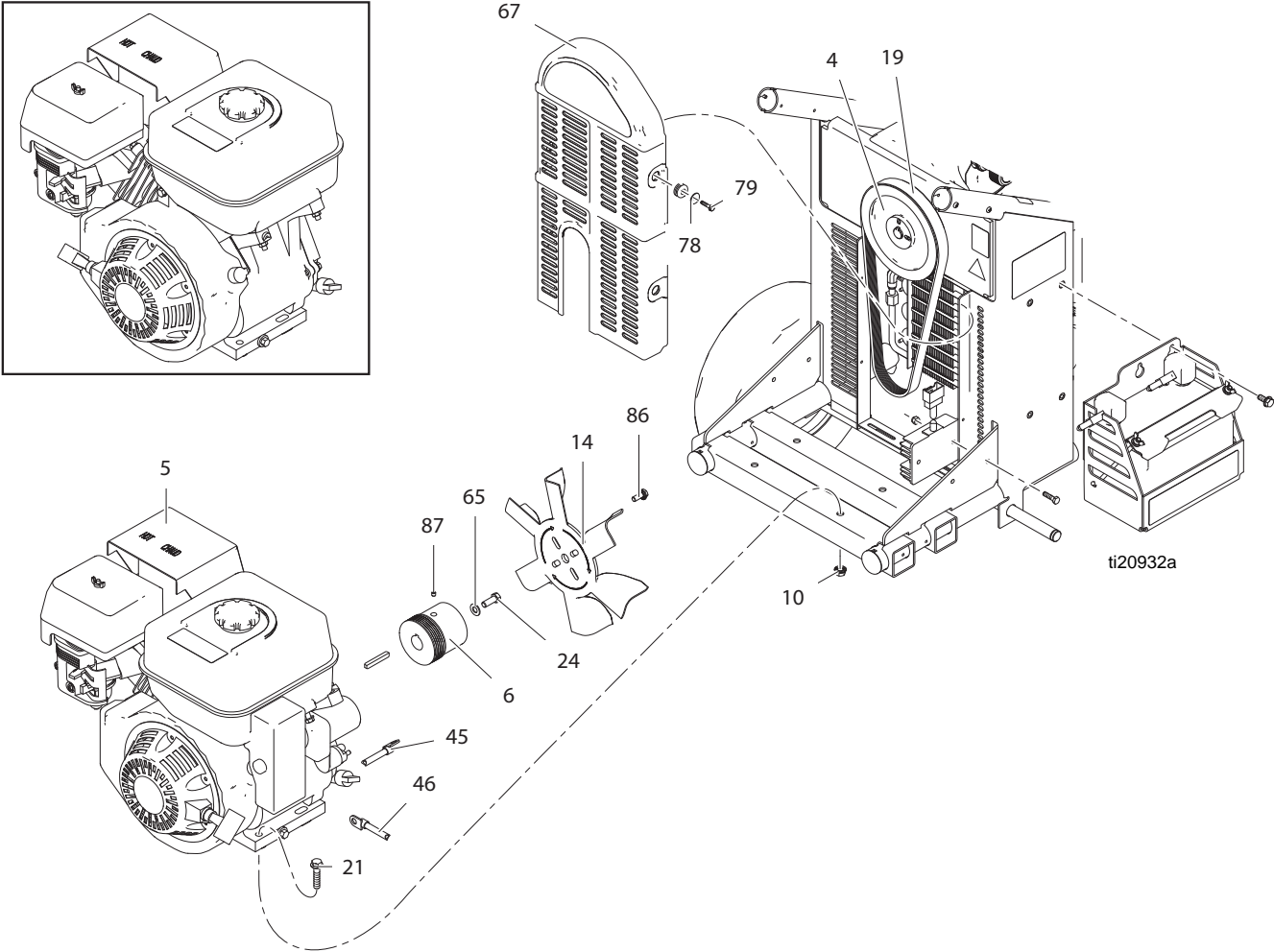

FIG. 1

# Battery Replacement

## Removal

1. Loosen wing nuts (48) and remove washers (58, 49), battery clamp (47), and hooks (38). Set parts aside.
2. Remove terminal covers (43, 44) and cables (45, 46) from battery lugs (33).
3. Dispose of battery per local codes and regulations.

## Installation

1. Place new battery (33) on pad (39).
2. Reconnect battery cables (45, 46) and terminal covers (43, 44) to battery.
3. Install battery clamp (47).

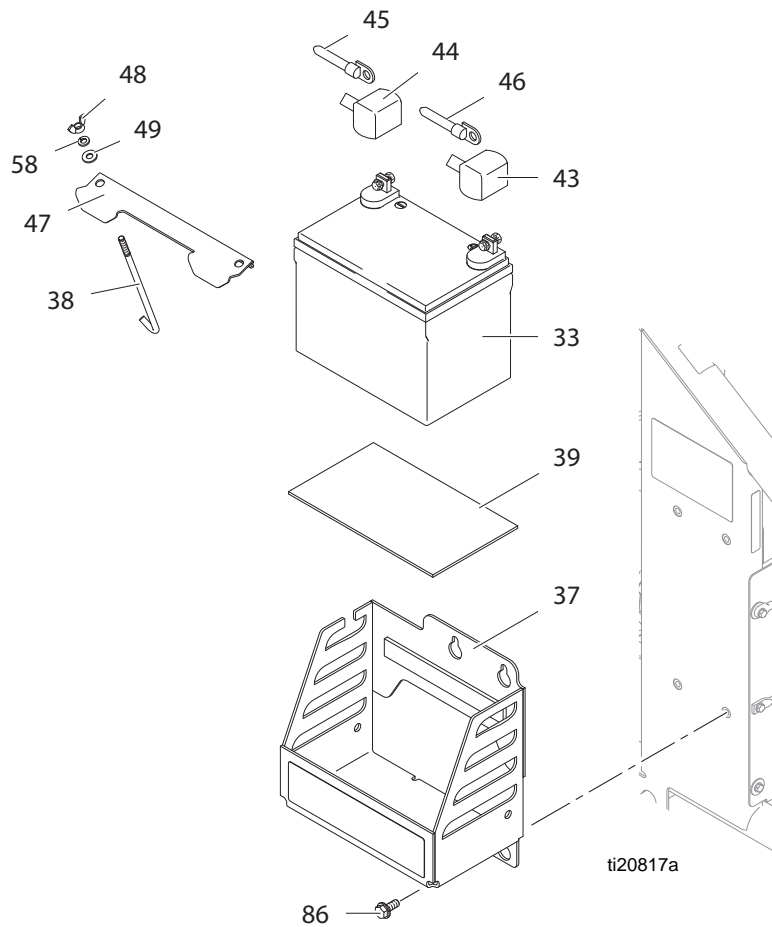



# Frame

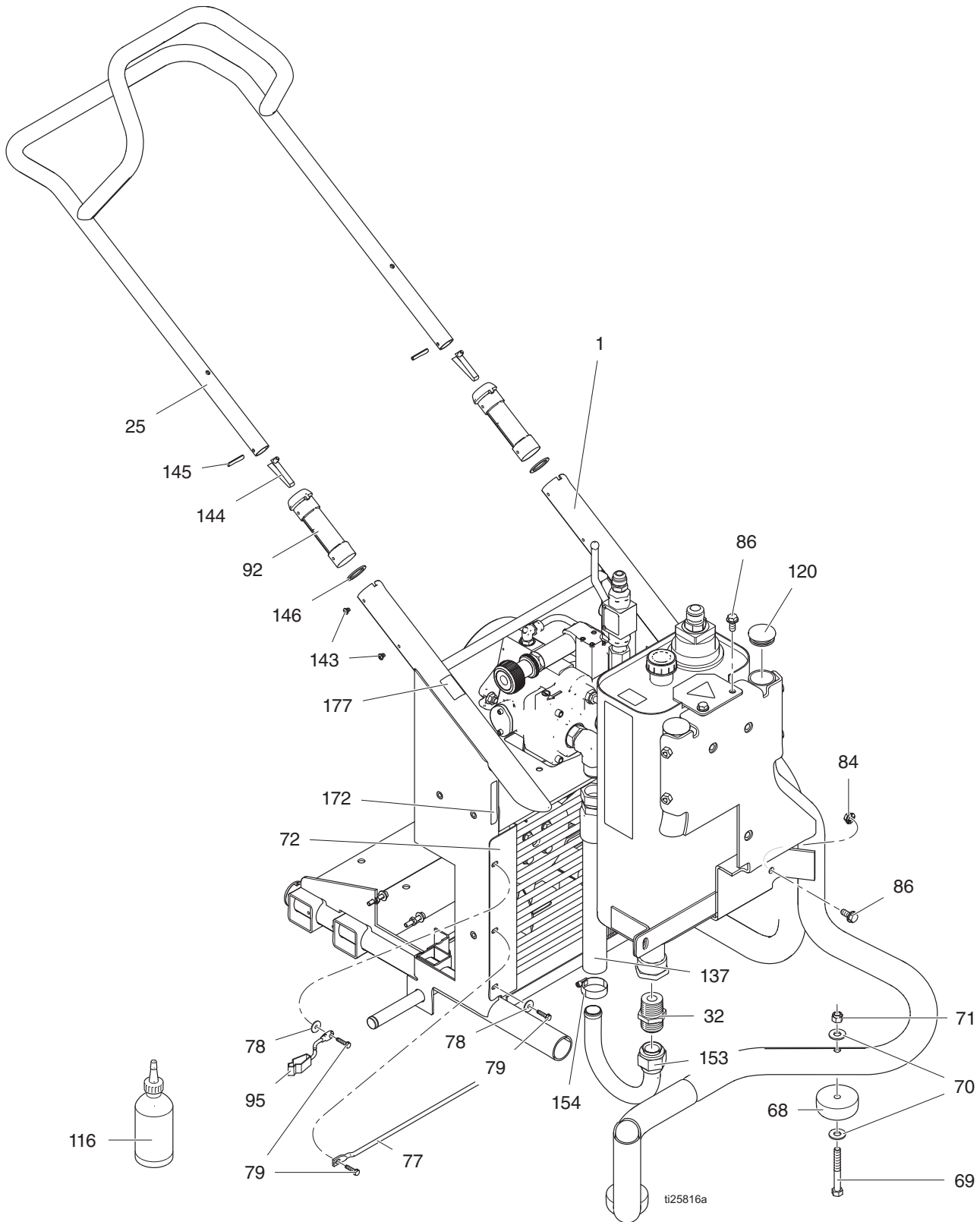



## Frame Parts List

Ref.	Part	Description	Qty.	Ref.	Part	Description	Qty.
1	15G839	FRAME, GH833, painted	1	95	237686	WIRE, ground assembly w/ clamp	1
25	287797	HANDLE, weldment, GH833	1	116	238049	FLUID, TSL, 4 oz	1
32	120068	FITTING, hydraulic	1	120	120314	PLUG, tube	4
68	801504	FOOT, rubber	2	137	15G813	HOSE, coupled	1
69	100454	SCREW, cap hex hd	2	143	109032	SCREW, mach, pnh	4
70	100132	WASHER, flat	4	144	112827	BUTTON, snap	2
71	101566	NUT, lock	2	145	108068	PIN, spring straight	2
72	287925	COOLER, oil	1	146	116891	WASHER	2
77	15H480	BAR, support	1	153	15G541	TUBE, J suction	1
78	120339	WASHER, fender	8	154	101818	CLAMP, hose	1
79	C20474	SCREW, self-tapping	10	172	15G906	LABEL, lift here	2
84	110996	NUT, hex, flange head	2	177	16D577	LABEL, USA made with Honda	1
86	110963	SCREW, cap, flange head	12				
92	15G797	SLEEVE, handle	2				

# Frame (continued)

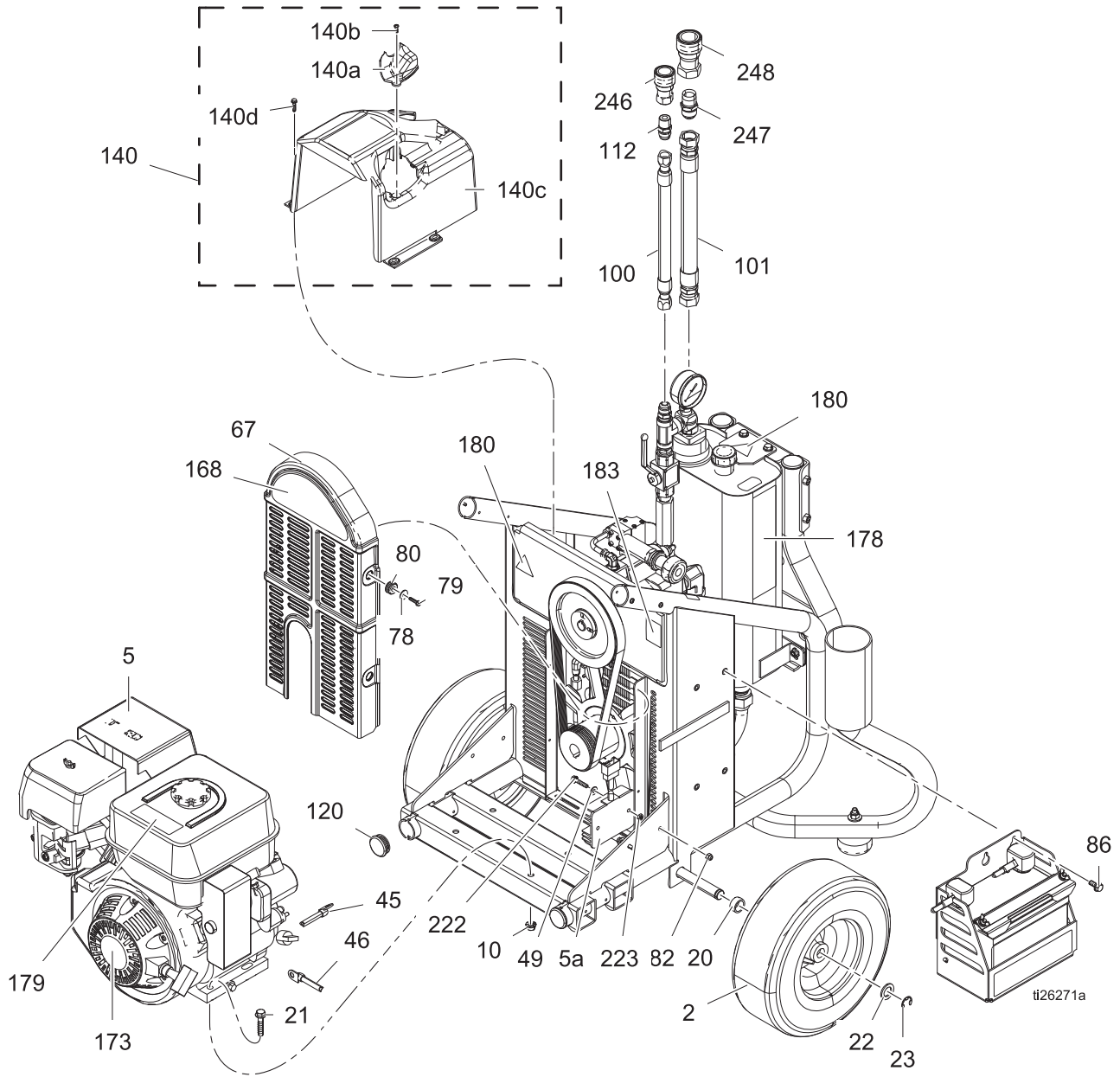

## Frame (Continued) Parts List

Ref.	Part	Description	Qty	Ref.	Part	Description	Qty
2	119509	WHEEL, pneumatic	2	112	120304	FITTING, nipple	1
5	16U399	ENGINE, gas, 13HP, electric start, 18amp	1	120	120314	PLUG, tube	4
5a		VOLTAGE REGULATOR (see Honda manual)	1	140	288098	KIT, repair, pump cover (includes 140a, 140b, 140c, 140d)	1
10	112958	NUT, hex, flanged	6	140a		COVER, pump handle	1
20	15G547	SPACER, axle	2	140b		SCREW, thread form, hi/lo	1
21	116780	SCREW, hex, hd, flanged	4	140c		COVER, pump	1
22	154628	WASHER	2	140d		SCREW, self-tapping	4
23	120211	RING, retaining, e-ring	2	168	16U558	LABEL, brand, big rig, rear	1
45	113951	CABLE, electric, neg	1	173	15G907	LABEL, Honda GX390 13HP	1
46	107073	CABLE, electric, positive	1	▲178	15D523	LABEL, warning, EN/FR/ES	1
49	110755	WASHER	2	▲179	194126	LABEL, warning	1
67	288099	KIT, repair, cover, fan pulley	1	▲180	189285	LABEL, caution	2
78	120339	WASHER, fender	8	▲183	198492	LABEL, warning	1
79	C20474	SCREW, self-tapping	10	222	120444	SCREW	2
80	120415	GROMMET, pulley fan GH833	4	223	101345	NUT	2
81	100021	SCREW, cap hex hd	2	246	17E120	FITTING, q.d., 1/2 in.	1
82	102040	WASHER, lock	2	247	127133	FITTING, nipple	1
86	110963	SCREW, cap, flange head	12	248	17E122	FITTING, q.d., 3/4 in.	1
100	17D581	HOSE, coupled	1	▲Replacement Danger and Warning labels, tags, and cards are available at no cost.			
101	17D582	HOSE, coupled	1				

# Hydraulic Pump and Reservoir

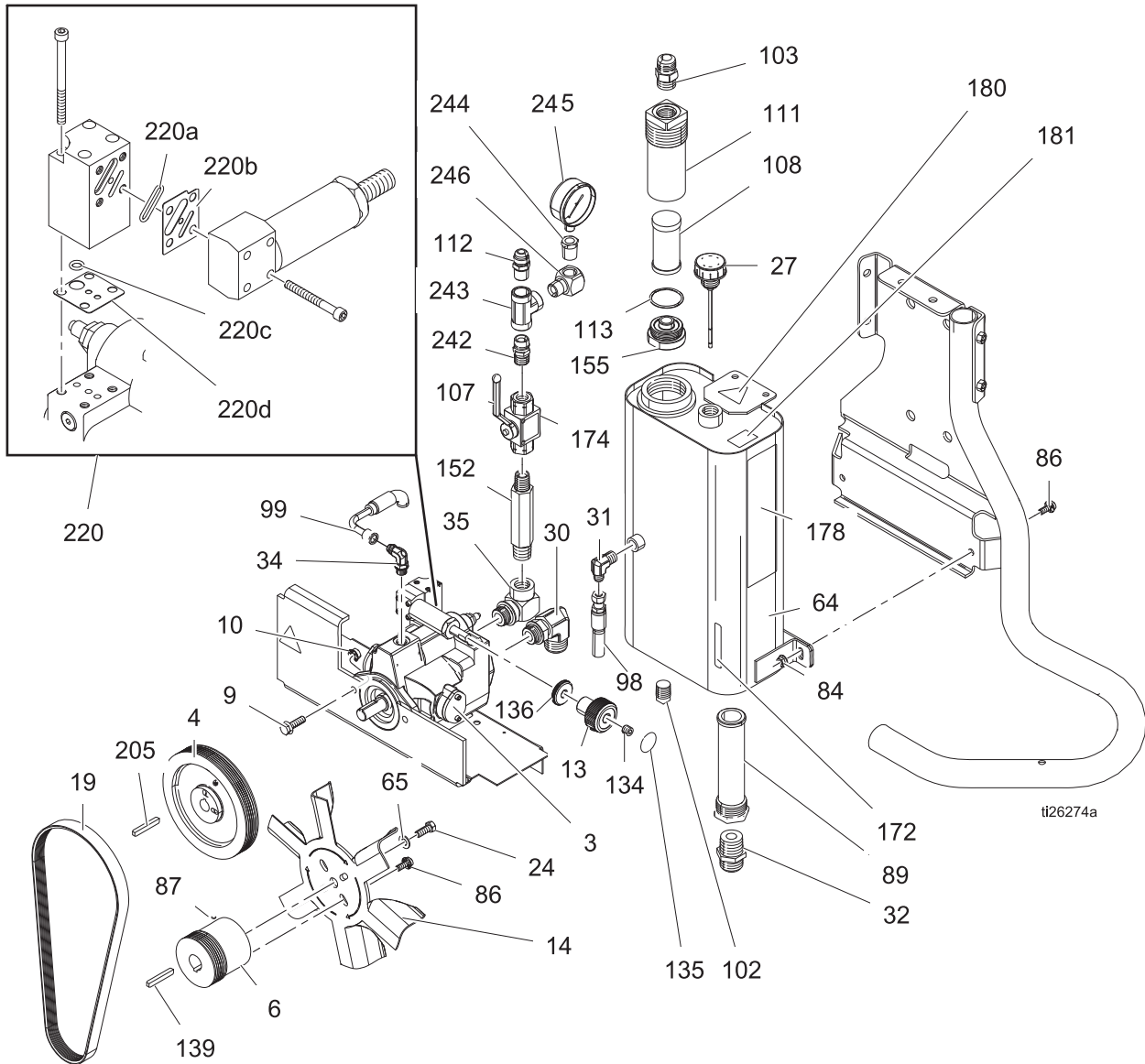

## Hydraulic Pump and Reservoir Parts List

Ref.	Part	Description	Qty	Ref.	Part	Description	Qty
3	24X189	PUMP, hydraulic (includes 9, 10, 13, 134, 135, 136)	1	112	120304	FITTING, nipple, straight	1
4	15G812	PULLEY, pump	1	113	120315	O-RING, packing	1
6	15G811	PULLEY, drive, engine	1	134	117560	SCREW, set, socket head	1
9	111193	SCREW, cap flange hd	2	135	15A464	LABEL, control	1
10	112958	NUT, hex, flanged	6	136	15G767	COLLAR, locking, pressure knob	1
13	15B438	KNOB, pressure	1	139	801137	KEY, engine, pulley	1
14	119971	FAN	1	152	120175	FITTING, ball valve	1
19	120172	BELT, poly-v	1	155	15H247	CAP, filter, hydraulic	1
24	116596	SCREW, cap, hex head	1	172	15G906	LABEL, lift here	2
27	17L161	CAP, oil fill	1	174	15G908	LABEL, hydraulic lever on/off	1
30	120066	FITTING, elbow, hydraulic	1	▲178	15D523	LABEL, warning, EN/FR/ES	1
31	120064	FITTING, elbow, hydraulic	1	▲180	189285	LABEL, caution	1
32	120068	FITTING, hydraulic	1	▲181	16P142	LABEL, hydraulic fluid only	1
34	116793	FITTING	1	205	183401	KEY, pump, pulley	1
35	120067	FITTING	1	220	287100	KIT, repair (includes 220a-220d)	1
64	15G545	RESERVOIR, painted	1	220a		O-RING, oval	
65	100731	WASHER	1	220b		GASKET, comp/block	
84	110996	NUT, hex, flange head	2	220c		O-RING	
86	110963	SCREW, cap, flange head	12	220d		GASKET, block/cover	
87	100002	SCREW, set, sch	3	242	158491	NIPPLE	1
89	120137	FILTER, suction	1	243	103475	FITTING, tee	1
98	15G784	HOSE, coupled	1	244	100206	ADAPTER	1
99	15G782	HOSE, coupled	1	245	102814	GAUGE, pressure	1
102	124489	PLUG, pipe	1	246	112307	ELBOW, street	1
103	120063	FITTING, hydraulic	1				
107	120140	VALVE, ball, assembly	1				
108	120310	FILTER, hydraulic fluid	1				
111	15H246	HOUSING, filter, hydraulic	1				

*Kit 287871 includes 108, 113*

▲ *Replacement Danger and Warning labels, tags, and cards are available at no cost.*

# Battery

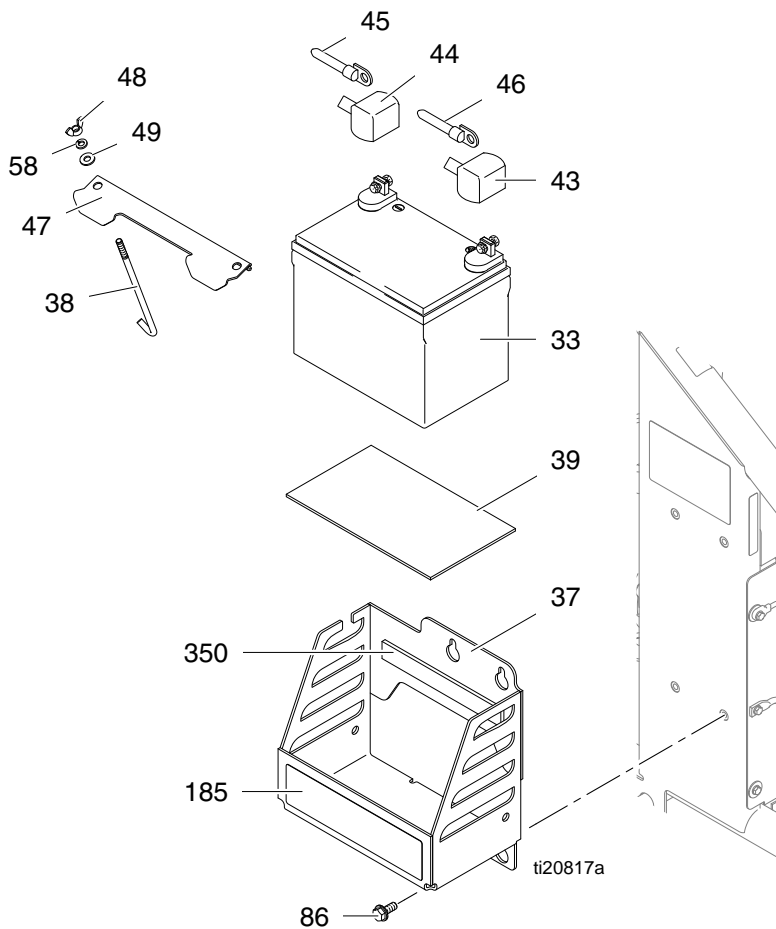

## Parts List

Ref.	Part	Description	Qty	Ref.	Part	Description	Qty
33	115753	BATTERY, 33 AH, sealed	1	47	107069	CLAMP, battery	1
37	16U412	TRAY, battery, gh-es, painted	1	48	100011	NUT, wing	2
38	107068	HOOK, bolt	2	49	110755	WASHER, plain	2
39	801972	PAD, battery	1	58	100016	WASHER, lock	2
43	801958	PROTECTOR, terminal, red	1	86	110963	SCREW, cap, flange head	12
44	801959	TERMINAL, protector, black	1	185	16U559	LABEL, brand, es, side	1
45	113951	CABLE, electric, neg (black)	1	350	15F366	PAD, foam	1
46	107073	CABLE, electric, positive (red)	1				

# Technical Data

<b>GH™ Power Pack</b>		
	<b>US</b>	<b>Metric</b>
Hydraulic Pressure	1800 psi	12.4 MPa, 124 bar
Hydraulic Reservoir Capacity	4.0 gallons	15.1 liters
Honda Motor	13 HP	9.7 KW
Hydraulic Supply	1/2 in JIC	
Return Line	3/4 in JIC	
<b>Dimensions</b>		
Weight	390 lb	177 kg
Height	49 in.	124 cm
Width	28 in.	71 cm
Length	43 in.	109 cm
<b>Sounds Levels (measured at maximum normal load conditions)</b>		
Sound Pressure (measured per ISO-9614-2)	91 dB(A)	
Sound Power	106 dB(A)	
<b>Miscellaneous</b>		
Graco-Approved Hydraulic Oil		
169236	5 gallons	19 liters
207428	1 gallon	3.8 liters

# Graco Standard Warranty

Graco warrants all equipment referenced in this document which is manufactured by Graco and bearing its name to be free from defects in material and workmanship on the date of sale to the original purchaser for use. With the exception of any special, extended, or limited warranty published by Graco, Graco will, for a period of twelve months from the date of sale, repair or replace any part of the equipment determined by Graco to be defective. This warranty applies only when the equipment is installed, operated and maintained in accordance with Graco's written recommendations.

This warranty does not cover, and Graco shall not be liable for general wear and tear, or any malfunction, damage or wear caused by faulty installation, misapplication, abrasion, corrosion, inadequate or improper maintenance, negligence, accident, tampering, or substitution of non-Graco component parts. Nor shall Graco be liable for malfunction, damage or wear caused by the incompatibility of Graco equipment with structures, accessories, equipment or materials not supplied by Graco, or the improper design, manufacture, installation, operation or maintenance of structures, accessories, equipment or materials not supplied by Graco.

This warranty is conditioned upon the prepaid return of the equipment claimed to be defective to an authorized Graco distributor for verification of the claimed defect. If the claimed defect is verified, Graco will repair or replace free of charge any defective parts. The equipment will be returned to the original purchaser transportation prepaid. If inspection of the equipment does not disclose any defect in material or workmanship, repairs will be made at a reasonable charge, which charges may include the costs of parts, labor, and transportation.

**THIS WARRANTY IS EXCLUSIVE, AND IS IN LIEU OF ANY OTHER WARRANTIES, EXPRESS OR IMPLIED, INCLUDING BUT NOT LIMITED TO WARRANTY OF MERCHANTABILITY OR WARRANTY OF FITNESS FOR A PARTICULAR PURPOSE.**

Graco's sole obligation and buyer's sole remedy for any breach of warranty shall be as set forth above. The buyer agrees that no other remedy (including, but not limited to, incidental or consequential damages for lost profits, lost sales, injury to person or property, or any other incidental or consequential loss) shall be available. Any action for breach of warranty must be brought within two (2) years of the date of sale.

**GRACO MAKES NO WARRANTY, AND DISCLAIMS ALL IMPLIED WARRANTIES OF MERCHANTABILITY AND FITNESS FOR A PARTICULAR PURPOSE, IN CONNECTION WITH ACCESSORIES, EQUIPMENT, MATERIALS OR COMPONENTS SOLD BUT NOT MANUFACTURED BY GRACO.** These items sold, but not manufactured by Graco (such as electric motors, switches, hose, etc.), are subject to the warranty, if any, of their manufacturer. Graco will provide purchaser with reasonable assistance in making any claim for breach of these warranties.

In no event will Graco be liable for indirect, incidental, special or consequential damages resulting from Graco supplying equipment hereunder, or the furnishing, performance, or use of any products or other goods sold hereto, whether due to a breach of contract, breach of warranty, the negligence of Graco, or otherwise.

## **FOR GRACO CANADA CUSTOMERS**

The Parties acknowledge that they have required that the present document, as well as all documents, notices and legal proceedings entered into, given or instituted pursuant hereto or relating directly or indirectly hereto, be drawn up in English. Les parties reconnaissent avoir convenu que la rédaction du présente document sera en Anglais, ainsi que tous documents, avis et procédures judiciaires exécutés, donnés ou intentés, à la suite de ou en rapport, directement ou indirectement, avec les procédures concernées.

# Graco Information

For the latest information about Graco products, visit [www.graco.com](http://www.graco.com).

For patent information, see [www.graco.com/patents](http://www.graco.com/patents).

**TO PLACE AN ORDER**, contact your Graco distributor or call 1-800-690-2894 to identify the nearest distributor.

*All written and visual data contained in this document reflects the latest product information available at the time of publication.  
Graco reserves the right to make changes at any time without notice.*

*For patent information, see [www.graco.com/patents](http://www.graco.com/patents).*

Original instructions. This manual contains English. MM 334914

**Graco Headquarters:** Minneapolis  
**International Offices:** Belgium, China, Japan, Korea

**GRACO INC. AND SUBSIDIARIES • P.O. BOX 1441 • MINNEAPOLIS MN 55440-1441 • USA**

**Copyright 2015, Graco Inc. All Graco manufacturing locations are registered to ISO 9001.**

[www.graco.com](http://www.graco.com)

Revision B, May 2016