



ProMix® PD2K Proportioner for Automatic Spray Applications

332458H
EN

Electronic positive displacement proportioner for fast-setting two-component materials. Automatic system with Advanced Display Module. For professional use only.



Important Safety Instructions

Read all warnings and instructions in this manual and in your operation, repair, and associated component manuals. Save these instructions.

See page 3 for model part numbers and approvals information.

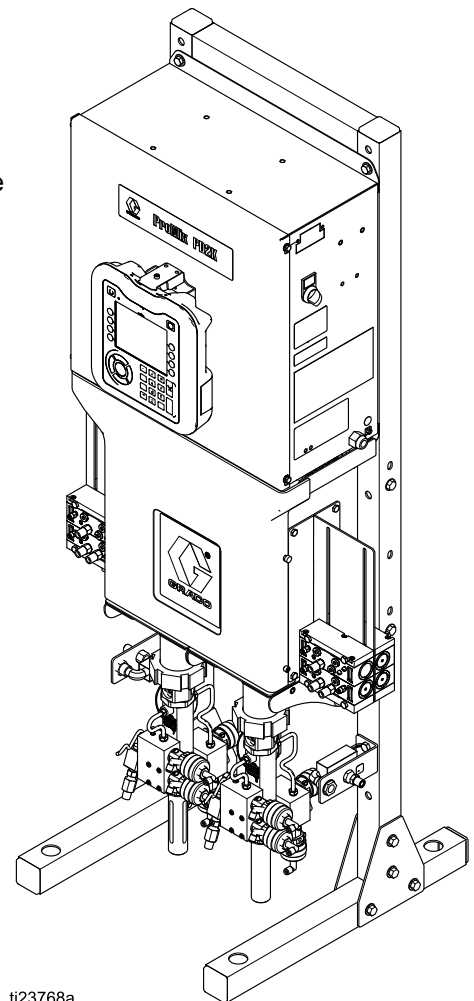

ti23768a

Contents

Related Manuals	2	Fluid Requirements	27
Models	3	Single Color Connections	28
Important Isocyanate (ISO) Information	9	Color Change Connections	28
Important Acid Catalyst Information	11	Solvent Connections	28
System Control Drawing 16P577	12	Dual Panel Solvent Connections	29
Configure Your System	14	PD3K+ Solvent Connections	29
1. Select a Base Model	14	TSL Cup Kit.....	30
2. Select Hoses	18	Alternate TSL Plumbing for	
3. Select Remote Mix Manifold	20	Highly-Reactive/Moisture-Sensitive	
4. Select a Spray Gun	20	ISO Catalyst PD2K Pumps	32
5. Select Color and Catalyst Change		Solvent Meter Accessory.....	34
Control Module Kits	21	Light Tower Accessory.....	34
6. Select Color and Catalyst Change		Electrical Supply.....	35
Manifold Kits	21	Electrical Requirements.....	35
7. Select Pump Expansion Kits	23	Electrical Connections	35
8. Select Communication Options	23	Grounding.....	37
9. Accessory Tool Kit	23	Electrical Schematics.....	39
10. Upgrade Kit	23	Standard Models (AC1000, AC2000,	
General Information	24	AC3000, AC4000)	39
Location.....	24	Dual Panel Models (AC1002, AC2002,	
Install the Display Module.....	25	AC3002, AC4002)	45
Upgrade Software for ProMix PD3K+		Optional Cables and Modules.....	51
System	25	Dimensions	52
Air Supply	26	Technical Data	53
Fluid Supply	27		

Related Manuals

Current manuals are available at www.graco.com.

Manual No.	Description
332709	PD2K Proportioner Repair-Parts Manual, Automatic Systems
332564	PD2K Proportioner Operation Manual, Automatic Systems
3A4486	PD2K Dual Panel Proportioner Manual, Automatic Systems
3A6287	PD3K+ Proportioner Operation Manual, Automatic Systems
332339	Pump Repair-Parts Manual
332454	Color/Catalyst Dispense Valves Instructions-Parts Manual

Manual No.	Description
332455	Color Change Kits Instructions-Parts Manual
333282	Color Change and Remote Mix Manifold Kits Instructions-Parts Manual
332456	3rd and 4th Pump Kits Instructions-Parts Manual
334494	ProMix PD2K CGM Installation Kits Instructions-Parts Manual

Models

See Figs. 1–7 for component identification labels, including approval information and certification.

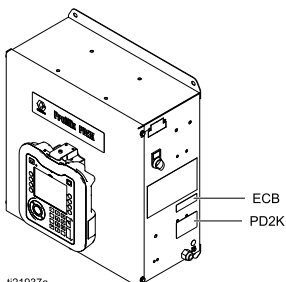
Part No.	Series	Maximum Air Working Pressure	Maximum Fluid Working Pressure	Location of PD2K and Electrical Control Box (ECB) Labels
AC0500 AC0502	A	100 psi (0.7 MPa, 7.0 bar)	With low-pressure pumps: 300 psi (2.068 MPa, 20.68 bar)	 <p>i21937a</p>
			With high-pressure pumps: 1500 psi (10.34 MPa, 103.4 bar)	
AC1000 AC1002	A	100 psi (0.7 MPa, 7.0 bar)	300 psi (2.068 MPa, 20.68 bar)	
AC3000 AC3002 Acid-based Material				
AC2000 AC2002	A	100 psi (0.7 MPa, 7.0 bar)	1500 psi (10.34 MPa, 103.4 bar)	
AC4000 AC4002 Acid-based Material				



**ProMix® PD
Electronic Proportioner**

Ex
II 2 G
Ex ia IIA T3
FM13 ATEX 0026
IECEX FMG 13.0011

CE 0359

ERC

FM
APPROVED
c FM US
FM16US0241
FM16CA0129
Intrinsically safe
equipment for Class I,
Div 1, Group D, T3
Ta = 2°C to 50°C

Intrinsically Safe (IS) System. Install per IS Control Drawing No. 16P577. Control Box IS Associated Apparatus for use in non hazardous location, with IS Connection to color change and booth control modules Apparatus for use in: Class I, Division 1, Group D T3 Hazardous Locations

Read Instruction Manual
Warning: Substitution of components may impair intrinsic safety.

MAX AIR WPR

.7	7	100
MPa	bar	PSI

MAX FLUID WPR

2.068	20.68	300
MPa	bar	PSI

MAX TEMP 50°C (122°F)

Artwork No. 294021 Rev. G

PART NO.	SERIES	SERIAL
MFG. YR.		

GRACO INC.
P.O. Box 1441
Minneapolis, MN
55440 U.S.A.

Figure 1 Model AC1000, AC1002, AC3000, and AC3002 (Low Pressure) Identification Label

Continued on the next page.

ProMix® PD			POWER REQUIREMENTS	
PART NO.	SERIES NO.	MFG. YR.	VOLTS	90-250 ~
[]	[]	[]	AMPS	7 AMPS MAX
			50/60 Hz	

GRACO INC.
P.O. Box 1441
Minneapolis, MN
55440 U.S.A.

APPROVED
FM16US0241
FM16CA0129
Intrinsically safe connections for Class I, Div 1, Group D
Ta = 2°C to 50°C
Install per 16P577

II (2) G
[Ex ia] IIA Gb
FM13 ATEX 0026
IECEX FMG 13.0011

0359

Um: 250 V Artwork No. 294024 Rev. E

Figure 2 24M672 and 26A188 Control Box Identification Label

ProMix® PD			Intrinsically Safe (IS) System. Install per IS Control Drawing No. 16P577. Control Box IS Associated Apparatus for use in non hazardous location, with IS Connection to color change and booth control modules Apparatus for use in: Class I, Division 1, Group D T3 Hazardous Locations Read Instruction Manual Warning: Substitution of components may impair intrinsic safety.	
Electronic Proportioner				

0359

II 2 G
Ex ia IIA T3
FM13 ATEX 0026
IECEX FMG 13.0011

APPROVED
FM16US0241
FM16CA0129
Intrinsically safe equipment for Class I, Div 1, Group D, T3
Ta = 2°C to 50°C

MAX AIR WPR

.7	7	100
MPa	bar	PSI

MAX FLUID WPR

10.34	103.4	1500
MPa	bar	PSI

MAX TEMP 50°C (122°F)

PART NO. SERIES SERIAL

[]	[]	[]
-----	-----	-----

MFG. YR.

[]	[]	[]
-----	-----	-----

GRACO INC.
P.O. Box 1441
Minneapolis, MN
55440 U.S.A.

Artwork No. 294022 Rev. G

Figure 3 Model AC2000, AC2002, AC4000, and AC4002 (High Pressure) Identification Label

ProMix® PD			Intrinsically Safe (IS) System. Install per IS Control Drawing No. 16P577. Control Box IS Associated Apparatus for use in non hazardous location, with IS Connection to color change and booth control modules Apparatus for use in: Class I, Division 1, Group D T3 Hazardous Locations Read Instruction Manual Warning: Substitution of components may impair intrinsic safety.	
Electronic Proportioner				

0359

II 2 G
Ex ia IIA T3
FM13 ATEX 0026
IECEX FMG 13.0011

APPROVED
FM16US0241
FM16CA0129
Intrinsically safe equipment for Class I, Div 1, Group D, T3
Ta = 2°C to 50°C

MAX AIR WPR

.7	7	100
MPa	bar	PSI

POWER REQUIREMENTS

90-250 ~	7 AMPS MAX
VOLTS	AMPS

50/60 Hz Um: 250 V

MAX TEMP 50°C (122°F)

PART NO. SERIES SERIAL

[]	[]	[]
-----	-----	-----

MFG. YR.

[]	[]	[]
-----	-----	-----

GRACO INC.
P.O. Box 1441
Minneapolis, MN
55440 U.S.A.

Artwork No. 294280 Rev. F

Figure 4 Model AC0500 and AC0502 Identification Label

ProMix® PD				COLOR CHANGE CONTROL		
PART NO.	SERIES	SERIAL	MFG. YR.	MAX AIR WPR		
[]	[]	[]	[]	.7	7	100
				MPa	bar	PSI

GRACO INC.
P.O. Box 1441
Minneapolis, MN
55440 U.S.A.

294057d

Figure 5 Non-Intrinsically Safe Color Change Control (Accessory) Identification Label

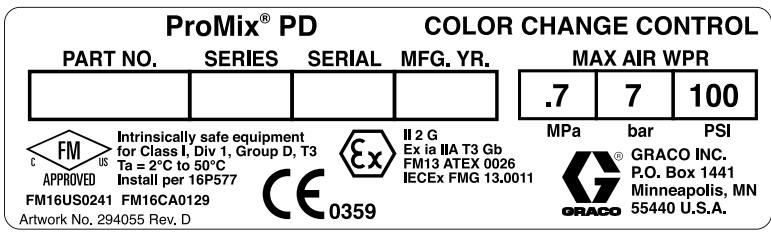

Figure 6 Inherently Safe Color Change Control (Accessory) Identification Label

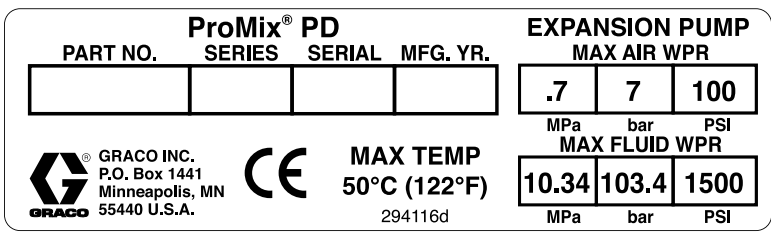

Figure 7 Pump Expansion Kit (Accessory) Identification Label

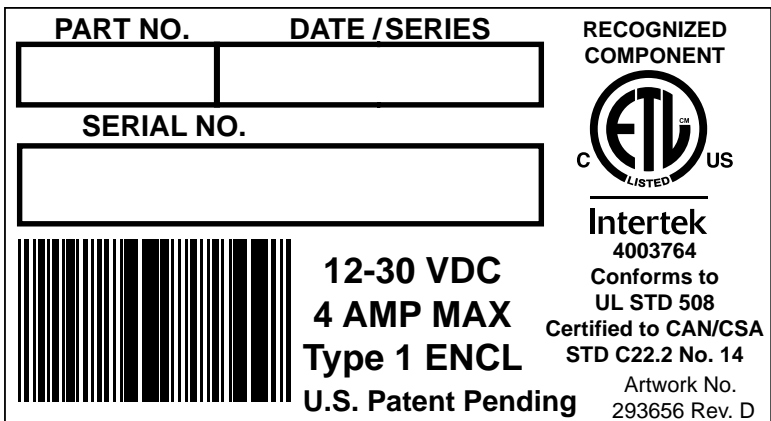

Figure 8 CGM Identification Label



WARNING



FIRE AND EXPLOSION HAZARD

Flammable fumes, such as solvent and paint fumes, in **work area** can ignite or explode. Paint or solvent flowing through the equipment can cause static sparking. To help prevent fire and explosion:



- Use equipment only in well ventilated area.
- Eliminate all ignition sources; such as pilot lights, cigarettes, portable electric lamps, and plastic drop cloths (potential static arc).



- Ground all equipment in the work area. See **Grounding** instructions.



- Never spray or flush solvent at high pressure.

- Keep work area free of debris, including solvent, rags and gasoline.

- Do not plug or unplug power cords, or turn power or light switches on or off when flammable fumes are present.

- Use only grounded hoses.

- Hold gun firmly to side of grounded pail when triggering into pail. Do not use pail liners unless they are antistatic or conductive.

- **Stop operation immediately** if static sparking occurs or you feel a shock, Do not use equipment until you identify and correct the problem.

- Keep a working fire extinguisher in the work area.



ELECTRIC SHOCK HAZARD

This equipment must be grounded. Improper grounding, setup, or usage of the system can cause electric shock.















- Turn off and disconnect power at main switch before disconnecting any cables and before servicing or installing equipment.

- Connect only to grounded power source.

- All electrical wiring must be done by a qualified electrician and comply with all local codes and regulations.



WARNING

  	<p>INTRINSIC SAFETY</p> <p>Intrinsically safe equipment that is installed improperly or connected to non-intrinsically safe equipment will create a hazardous condition and can cause fire, explosion, or electric shock. Follow local regulations and the following safety requirements.</p> <ul style="list-style-type: none"> • Be sure your installation complies with national, state, and local codes for the installation of electrical apparatus in a Class I, Group D, Division 1 (North America) or Class I, Zones 1 and 2 (Europe) Hazardous Location, including all of the local safety fire codes (for example, NFPA 33, NEC 500 and 516, OSHA 1910.107, etc.). • To help prevent fire and explosion: <ul style="list-style-type: none"> • Do not install equipment approved only for a non-hazardous location in a hazardous location. See model ID label for the intrinsic safety rating of your model. • Do not substitute system components as this may impair intrinsic safety. • Equipment that comes in contact with the intrinsically safe terminals must be rated for Intrinsic Safety. This includes DC voltage meters, ohmmeters, cables, and connections. Remove the unit from the hazardous area when troubleshooting.
    	<p>SKIN INJECTION HAZARD</p> <p>High-pressure fluid from gun, hose leaks, or ruptured components will pierce skin. This may look like just a cut, but it is a serious injury that can result in amputation. Get immediate surgical treatment.</p> <ul style="list-style-type: none"> • Do not spray without tip guard and trigger guard installed. • Engage trigger lock when not spraying. • Do not point gun at anyone or at any part of the body. • Do not put your hand over the spray tip. • Do not stop or deflect leaks with your hand, body, glove, or rag. • Follow the Pressure Relief Procedure when you stop spraying/dispensing and before cleaning, checking, or servicing equipment. • Tighten all fluid connections before operating the equipment. • Check hoses and couplings daily. Replace worn or damaged parts immediately.
 	<p>MOVING PARTS HAZARD</p> <p>Moving parts can pinch, cut or amputate fingers and other body parts.</p> <ul style="list-style-type: none"> • Keep clear of moving parts. • Do not operate equipment with protective guards or covers removed. • Pressurized equipment can start without warning. Before checking, moving, or servicing equipment, follow the Pressure Relief Procedure and disconnect all power sources.
 	<p>TOXIC FLUID OR FUMES</p> <p>Toxic fluids or fumes can cause serious injury or death if splashed in the eyes or on skin, inhaled, or swallowed.</p> <ul style="list-style-type: none"> • Read Safety Data Sheet (SDS) for handling instructions and to know the specific hazards of the fluids you are using, including the effects of long-term exposure. • When spraying, servicing equipment, or when in the work area, always keeps work area well ventilated and always wear appropriate personal protective equipment. See Personal Protective Equipment warnings in this manual. • Store hazardous fluid in approved containers, and dispose of it according to applicable guidelines.



WARNING



PERSONAL PROTECTIVE EQUIPMENT

Always wear appropriate personal protective equipment and cover all skin when spraying, servicing equipment, or when in the work area. Protective equipment helps prevent serious injury, including long-term exposure; inhalation of toxic fumes, mists, or vapors; allergic reactions; burns; eye injury and hearing loss. This protective equipment includes, but is not limited to:

- A properly fitting respirator, which may include a supplied-air respirator, chemically impermeable gloves, protective clothing and foot coverings as recommended by the fluid manufacturer and local regulatory authority.
- Protective eyewear, and hearing protection.



EQUIPMENT MISUSE HAZARD

Misuse can cause death or serious injury.







- Do not operate the unit when fatigued or under the influence of drugs or alcohol.
- Do not exceed the maximum working pressure or temperature rating of the lowest rated system component. See **Technical Data** in all equipment manuals.
- Use fluids and solvents that are compatible with equipment wetted parts. See **Technical Data** in all equipment manuals. Read fluid and solvent manufacturer's warnings. For complete information about your material, request SDS from distributor or retailer.
- Do not leave the work area while equipment is energized or under pressure.
- Turn off all equipment and follow the **Pressure Relief Procedure** when equipment is not in use.
- Check equipment daily. Repair or replace worn or damaged parts immediately with genuine manufacturer's replacement parts only.
- Do not alter or modify equipment. Alterations or modifications may void agency approvals and create safety hazards.
- Make sure all equipment is rated and approved for the environment in which you are using it.
- Use equipment only for its intended purpose. Call your distributor for information.
- Route hoses and cables away from traffic areas, sharp edges, moving parts, and hot surfaces.
- Do not kink or over bend hoses or use hoses to pull equipment.
- Keep children and animals away from work area.
- Comply with all applicable safety regulations.

Important Isocyanate (ISO) Information

Isocyanates (ISO) are catalysts used in two component materials.



Isocyanate Conditions

				
---	---	---	---	--

Spraying or dispensing fluids that contain isocyanates creates potentially harmful mists, vapors, and atomized particulates



- Read and understand the fluid manufacturer's warnings and Safety Data Sheet (SDS) to know specific hazards and precautions related to isocyanates.
- Use of isocyanates involves potentially hazardous procedures. Do not spray with the equipment unless you are trained, qualified, and have read and understood the information in this manual and in the fluid manufacturer's application instructions and SDS.
- Use of incorrectly maintained or mis-adjusted equipment may result in improperly cured material. Equipment must be carefully maintained and adjusted according to instructions in the manual.
- To prevent inhalation of isocyanate mists, vapors, and atomized particulates, everyone in the work area must wear appropriate respiratory protection. Always wear a properly fitting respirator, which may include a supplied-air respirator. Ventilate the work area according to instructions in the fluid manufacturer's SDS.
- Avoid all skin contact with isocyanates. Everyone in the work area must wear chemically impermeable gloves, protective clothing and foot coverings as recommended by the fluid manufacturer and local regulatory authority. Follow all fluid manufacturer recommendations, including those regarding handling of contaminated clothing. After spraying, wash hands and face before eating or drinking.

Material Self-ignition

				
---	--	--	--	--

Some materials may become self-igniting if applied too thick. Read material manufacturer's warnings and Safety Data Sheet (SDS).

Keep Components A and B Separate

				
---	--	---	--	--

Cross-contamination can result in cured material in fluid lines which could cause serious injury or damage equipment. To prevent cross-contamination:

- **Never** interchange component A and component B wetted parts.
- Never use solvent on one side if it has been contaminated from the other side.

Moisture Sensitivity of Isocyanates

Exposure to moisture (such as humidity) will cause ISO to partially cure; forming small, hard, abrasive crystals, which become suspended in the fluid. Eventually a film will form on the surface and the ISO will begin to gel, increasing in viscosity.

NOTICE

Partially cured ISO will reduce performance and the life of all wetted parts.

- Always use a sealed container with a desiccant dryer in the vent, or a nitrogen atmosphere. **Never** store ISO in an open container.
- Keep the ISO pump wet cup or reservoir (if installed) filled with appropriate lubricant. The lubricant creates a barrier between the ISO and the atmosphere.
- Use only moisture-proof hoses compatible with ISO.
- Never use reclaimed solvents, which may contain moisture. Always keep solvent containers closed when not in use.
- Always lubricate threaded parts with an appropriate lubricant when reassembling.

NOTE: The amount of film formation and rate of crystallization varies depending on the blend of ISO, the humidity, and the temperature.

Changing Materials

NOTICE







Changing the material types used in your equipment requires special attention to avoid equipment damage and downtime.

- When changing materials, flush the equipment multiple times to ensure it is thoroughly clean.
- Always clean the fluid inlet strainers after flushing.
- Check with your material manufacturer for chemical compatibility.
- When changing between epoxies and urethanes or polyureas, disassemble and clean all fluid components and change hoses. Epoxies often have amines on the B (hardener) side. Polyureas often have amines on the A (resin) side.

Important Acid Catalyst Information

Only the PD2K Proportioner acid catalyst models are designed for acid catalysts (“acid”) currently used in two-component, wood-finishing materials. Current acids in use (with pH levels as low as 1) are more corrosive than earlier acids. More corrosion-resistant wetted materials of construction are required, and must be used without substitution, to withstand the increased corrosive properties of these acids.

Acid Catalyst Conditions

									
---	---	---	---	---	---	--	--	--	--

Acid is flammable, and spraying or dispensing acid creates potentially harmful mists, vapors, and atomized particulates. To help prevent fire and explosion and serious injury:

- Read and understand the acid manufacturer’s warnings and Safety Data Sheet (SDS) to know specific hazards and precautions related to the acid.
- Use only genuine, manufacturer’s recommended acid-compatible parts in the catalyst system (hoses, fittings, etc). A reaction may occur between any substituted parts and the acid.
- To prevent inhalation of acid mists, vapors, and atomized particulates, everyone in the work area must wear appropriate respiratory protection. Always wear a properly fitting respirator, which may include a supplied-air respirator. Ventilate the work area according to instructions in the acid manufacturer’s SDS.
- Avoid all skin contact with acid. Everyone in the work area must wear chemically impermeable gloves, protective clothing, foot coverings, aprons, and face shields as recommended by the acid manufacturer and local regulatory authority. Follow all acid manufacturer recommendations, including those regarding handling of contaminated clothing. Wash hands and face before eating or drinking.
- Regularly inspect equipment for potential leaks and remove spills promptly and completely to avoid direct contact or inhalation of the acid and its vapors.
- Keep acid away from heat, sparks, and open flames. Do not smoke in the work area. Eliminate all ignition sources.
- Store acid in the original container in a cool, dry, and well-ventilated area away from direct sunlight and away from other chemicals in accordance with acid manufacturer’s recommendations. To avoid corrosion of containers, do not store acid in substitute containers. Reseal the original container to prevent vapors from contaminating the storage space and surrounding facility.

Moisture Sensitivity of Acid Catalysts

Acid catalysts can be sensitive to atmospheric moisture and other contaminants. It is recommended the catalyst pump and valve seal areas exposed to atmosphere are flooded with ISO oil, TSL, or other compatible material to prevent acid build-up and premature seal damage and failure.

NOTICE
<p>Acid build-up will damage the valve seals and reduce the performance and life of the catalyst pump. To prevent exposing acid to moisture:</p> <ul style="list-style-type: none"> • Always use a sealed container with a desiccant dryer in the vent, or a nitrogen atmosphere. Never store acids in an open container. • Keep the catalyst pump and the valve seals filled with the appropriate lubricant. The lubricant creates a barrier between the acid and the atmosphere. • Use only moisture-proof hoses compatible with acids. • Always lubricate threaded parts with an appropriate lubricant when reassembling.

System Control Drawing 16P577



Do not substitute or modify system components as this may impair intrinsic safety. For installation, maintenance, or operation instructions, read instruction manuals. Do not install equipment approved only for non-hazardous location in a hazardous location. See the identification label for the intrinsic safety rating for your model.

NOTES FOR SYSTEM CONTROL DRAWING 16P577 (FM13ATEX0026 SYSTEM ASSEMBLY CERTIFICATE)

	Alternate M12 CAN Cables, for Hazardous Locations	
	Cable Part No.	Length ft (m)
	16V423	2.0 (0.6)
	16V424	3.0 (1.0)
	16V425	6.0 (2.0)
	16V426	10.0 (3.0)
	16V427	15.0 (5.0)
	16V428	25.0 (8.0)
	16V429	50.0 (16.0)
16V430	100.0 (32.0)	
<p>2. The non-intrinsically safe terminals (power rail) must not be connected to any device which uses or generates more than $U_m = 250$ Vrms or dc unless it has been determined that the voltage has been adequately isolated.</p>		
<p>3. The electrical enclosure ground screw must be connected to a true earth ground using the supplied ground strap (223547) or by an equivalent 10 AWG or larger isolated conductor. Resistance from the electrical enclosure ground to the true earth ground shall not exceed 1 ohm.</p>		
<p>4. Multiple earthing of components is allowed. Intrinsically safe apparatus provides isolation from earth to 500 Vrms.</p>		
<p> Do not operate system with power barrier cover removed.</p>		
<p>6. Installation should be in accordance with ANSI/ISA RP12.06.01 "Installation of Intrinsically Safe Systems for Hazardous (Classified) Locations" and the National Electrical Code® (ANSI/NFPA 70).</p>		
<p>7. Installation in Canada should be in accordance with the Canadian Electrical Code, CAS C22.1, Part I, Appendix F.</p>		
<p>8. For ATEX, install per EN 60079-14 and applicable local and national codes.</p>		
<p>9. For IECEx install per IEC 60079-14 and applicable local and national codes.</p>		

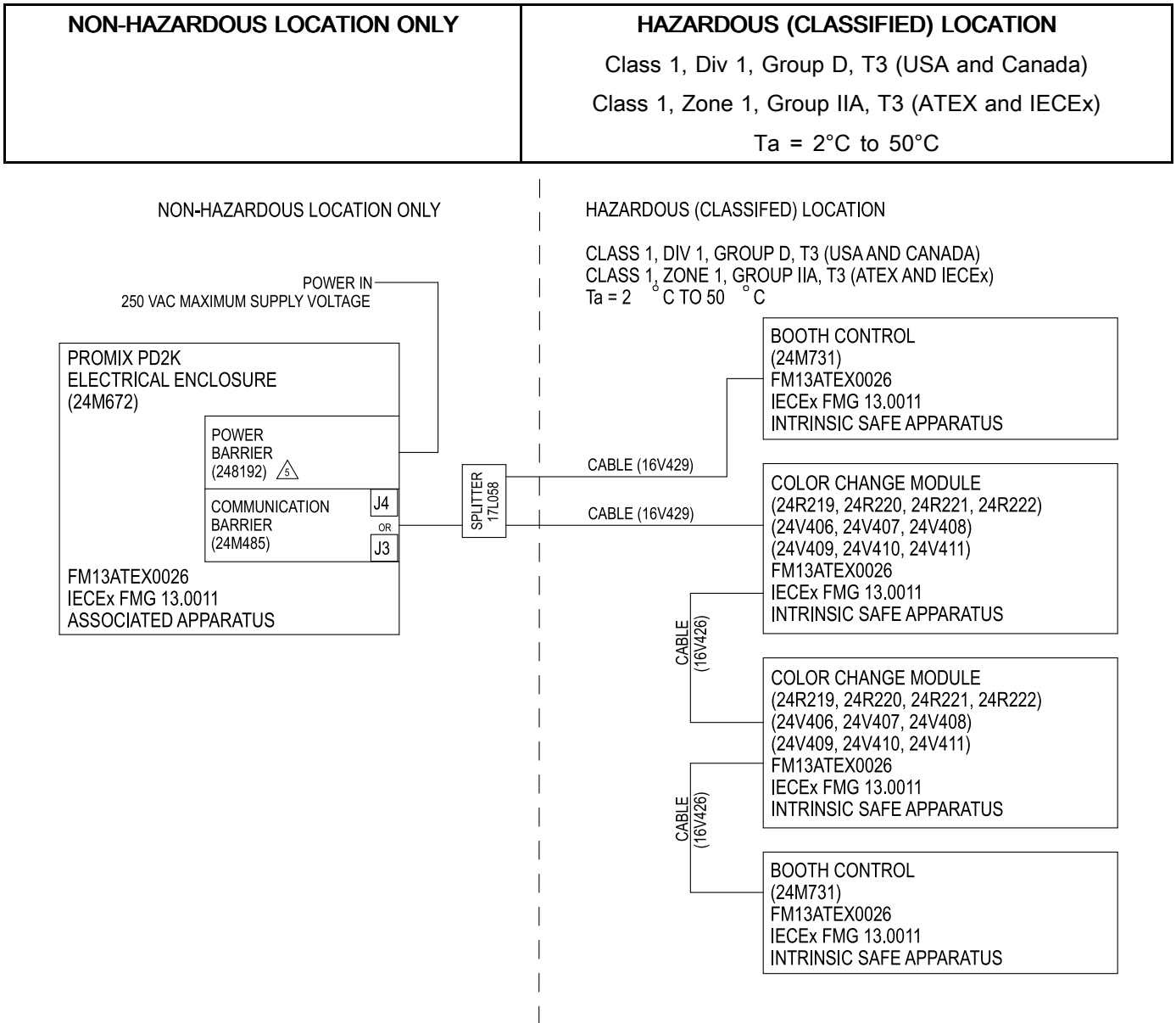

Figure 9 System Control Drawing 16P577

Configure Your System

1. Select a Base Model

Choose a ProMix PD base model that meets your application's requirements. See [Models, page 3](#).

Base unit components are described in the following table.

Base models include components A through F shown in the Typical Installation drawing on the next page.

Component	Description
Fluid Pumps (A, B)	The base models include two fluid pumps, one for resin and one for catalyst. Install in the non-hazardous area.
Solvent Flow Switch (C)	Confirms solvent flow to gun during purge. The base models include two solvent flow switches; one for resin, and one for catalyst.
Electrical Control Box (D)	The electrical control box includes a barrier board, intrinsically safe isolation board, 24 Vdc and 48 Vdc power supplies, Enhanced Fluid Control Module, and Pump Control Modules. The Gateway communication module is installed in the electrical control box. It accepts 90–250 Vac line power and converts that power to acceptable low voltage signals used by other system components. Install the electrical control box in the non-hazardous area.
Advanced Display Module (E)	The Advanced Display Module (ADM) enables the user to setup, monitor, and control the system. Install the ADM in the non-hazardous area.
CAN cable (F)	The CAN cable connects the Gateway communication module to the IS remote mix control module.

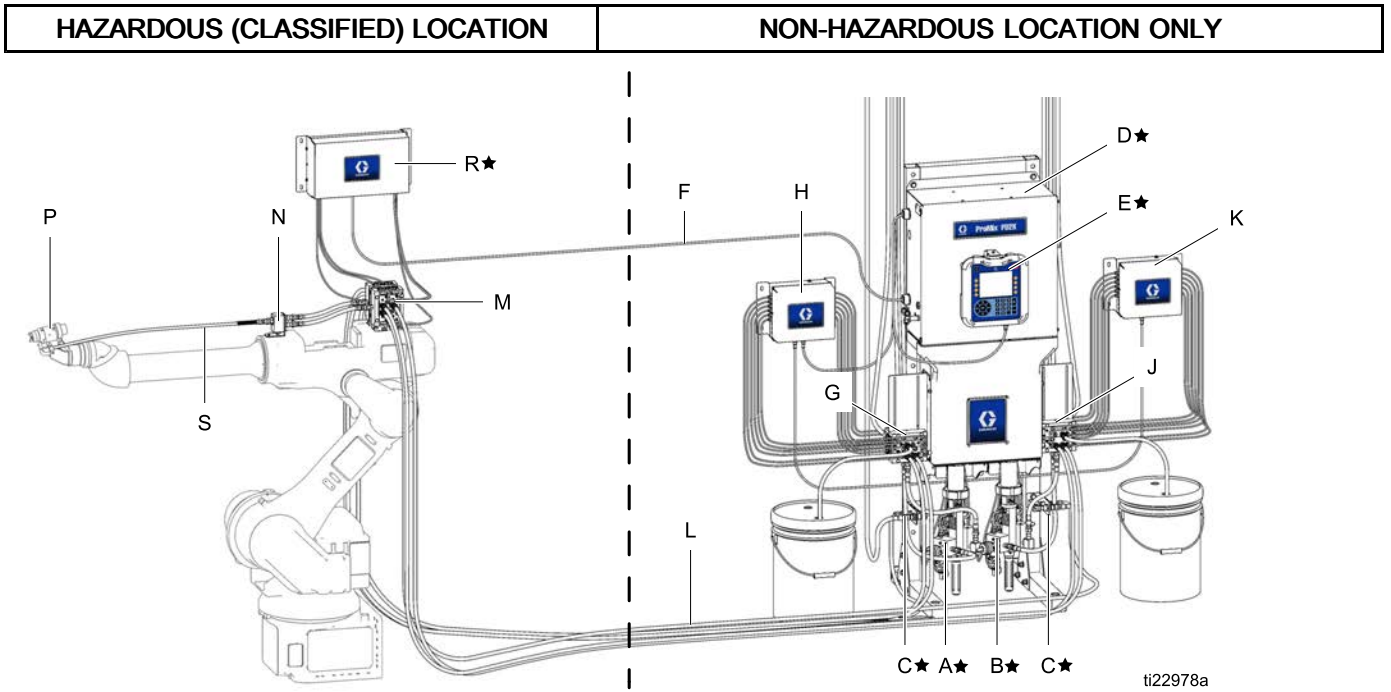

Figure 10 Typical Installation

Component	Description
★ Components A through F are included with the base unit.	
A★	Material A (Color) Pump
B★	Material B (Catalyst) Pump
C★	Solvent Flow Switch
D★	Electrical Control Box
E★	Advanced Display Module
F★	CAN Communication Cable
Components G through K are included in optional color change kits.	
G	Color Change Valves (accessory, non-hazardous area)
H	Color Change Module (accessory, non-hazardous area)
J	Catalyst Change Valves (accessory, non-hazardous area)
K	Catalyst Change Module (accessory, non-hazardous area)
Components L through S are accessories and must be ordered separately.	
L	Fluid/Air Hose Bundle (accessory)
M	Remote Color Change Manifold (accessory, hazardous area)
N	Remote Mix Manifold (accessory, hazardous area)
P	Automatic Spray Gun (accessory)
R	IS Remote Mix Control Module (accessory, hazardous area)
S	Gun Fluid Hose (accessory)
T	Supply Line Drain Valves (accessory, required, not shown)

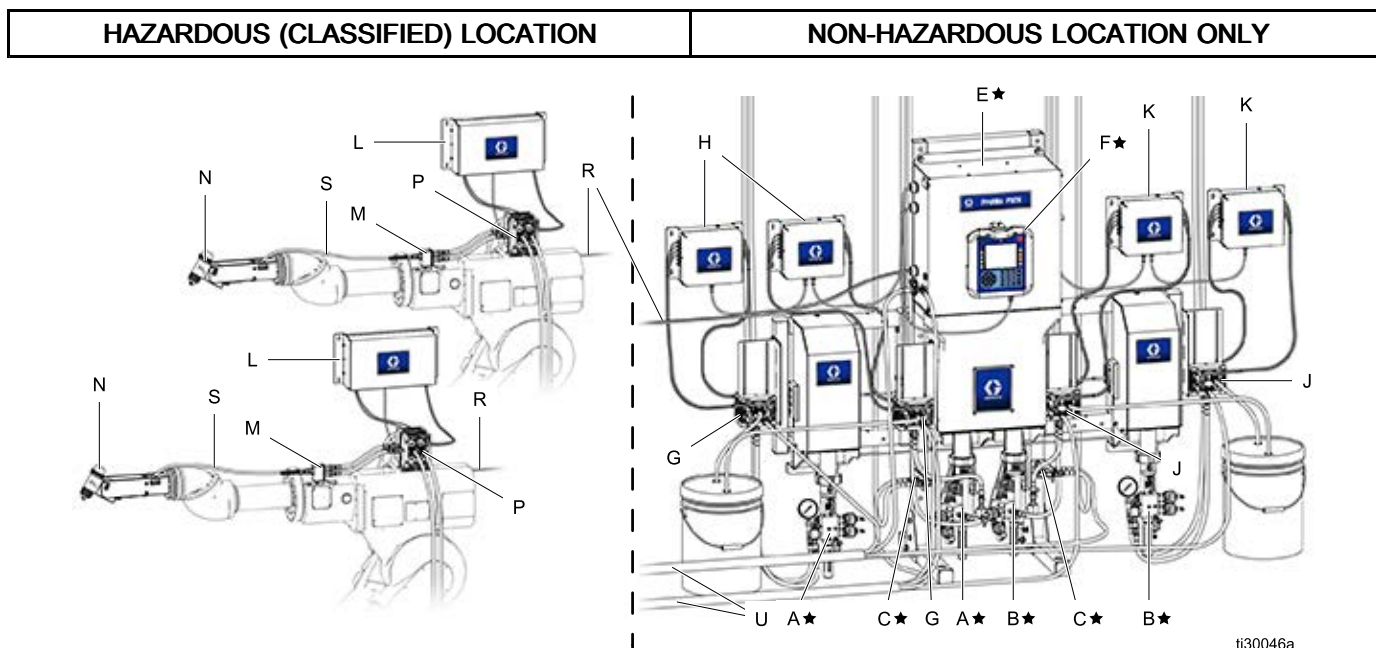
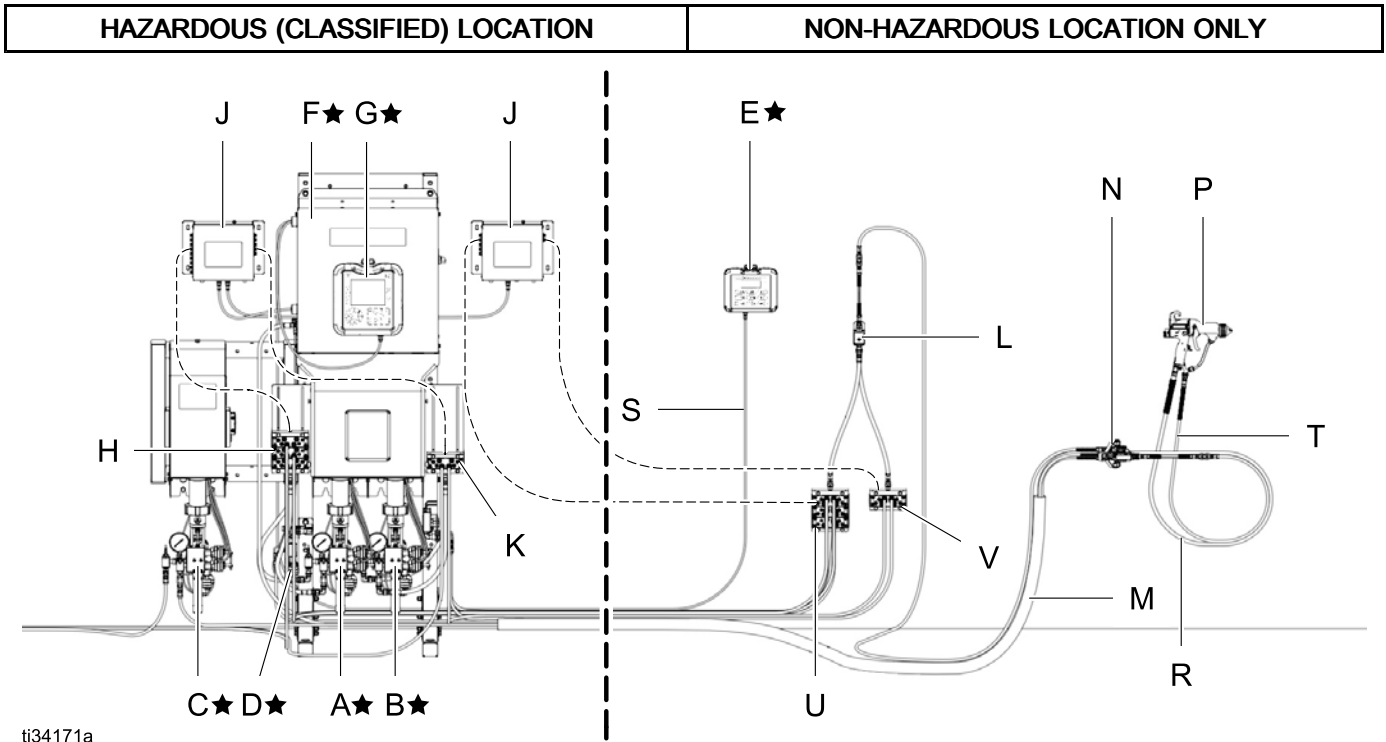

Figure 11 Typical Dual Panel Installation (AC1002 and AC2002 only)

Component	Description
★ Components A through F are included with the base unit.	
A★	Material A (Color) Pump
B★	Material B (Catalyst) Pump
C★	Solvent Flow Switches
E★	Electrical Control Box
F★	Advanced Display Module
Components G through K are included in optional color change kits.	
G	Color Change Valves (accessory)
H	Color Change Module (accessory)
J	Catalyst Change Valves (accessory)
K	Catalyst Change Module (accessory)
Components L through T are accessories and must be ordered separately.	
L	IS Remote Mix Control Module (accessory, hazardous area)
M	Remote Mix Manifold (accessory, hazardous area)
N	Automatic Spray Gun (accessory)
P	Remote Color Change Manifold (accessory, hazardous area)
R	CAN Communication Cable (accessory)
S	Gun Fluid Hose (accessory)
T	Supply Line Drain Valves (accessory, required, not shown)
U	Fluid/Air Hose Bundle (accessory)



ti34171a

Figure 12 Typical PD3K+ Installation (AC1000, AC2000, AC3000, AC4000)

Component	Description
★ Components A through F are included with the base unit.	
A★	Material A Pump
B★	Material B Pump
C★	Material C Pump
D★	Solvent Valve
E★	Booth Control
F★	Electrical Control Box
G★	Advanced Display Module
Components G through K are included in optional color change kits.	
H	Color Change Valves (accessory)
J	Color Change Module (accessory)
K	Catalyst Change Valves (accessory)
L	Remote Mix Manifold
Components L through S are accessories and must be ordered separately.	
M	Fluid/Air Hose Bundle (accessory) — see PD2K Installation Manual (332458) for acid-compatible hose bundles
N	Mix Manifold (accessory) — see Mix Manifold Instruction-Parts Manual (3A2801) for acid-compatible mix manifolds
P	Air Spray Gun (accessory)
R	Gun Air Hose (accessory)
S	Intrinsically Safe CAN Cable (to connect booth control to electrical control box)
T	Gun Fluid Hose (accessory)
U	Remote Color Change Valves
V	Remote Catalyst Change Valves

2. Select Hoses

Hose Selection Tool

Use this chart to determine the proper size hose bundle for your mix ratio and viscosity, then select a hose bundle for your application from the tables on the following page.

NOTE: Always use Graco hoses.

NOTE: Shaded areas may use hose sizes from either of the two adjacent areas.

NOTE: When using the following chart for line selection with a 3K manifold, use a two-step selection process; first the A:B lines, and then the A:C lines. When sizing results differ, select the larger recommended A lines, and the smaller recommended B and C side hoses.

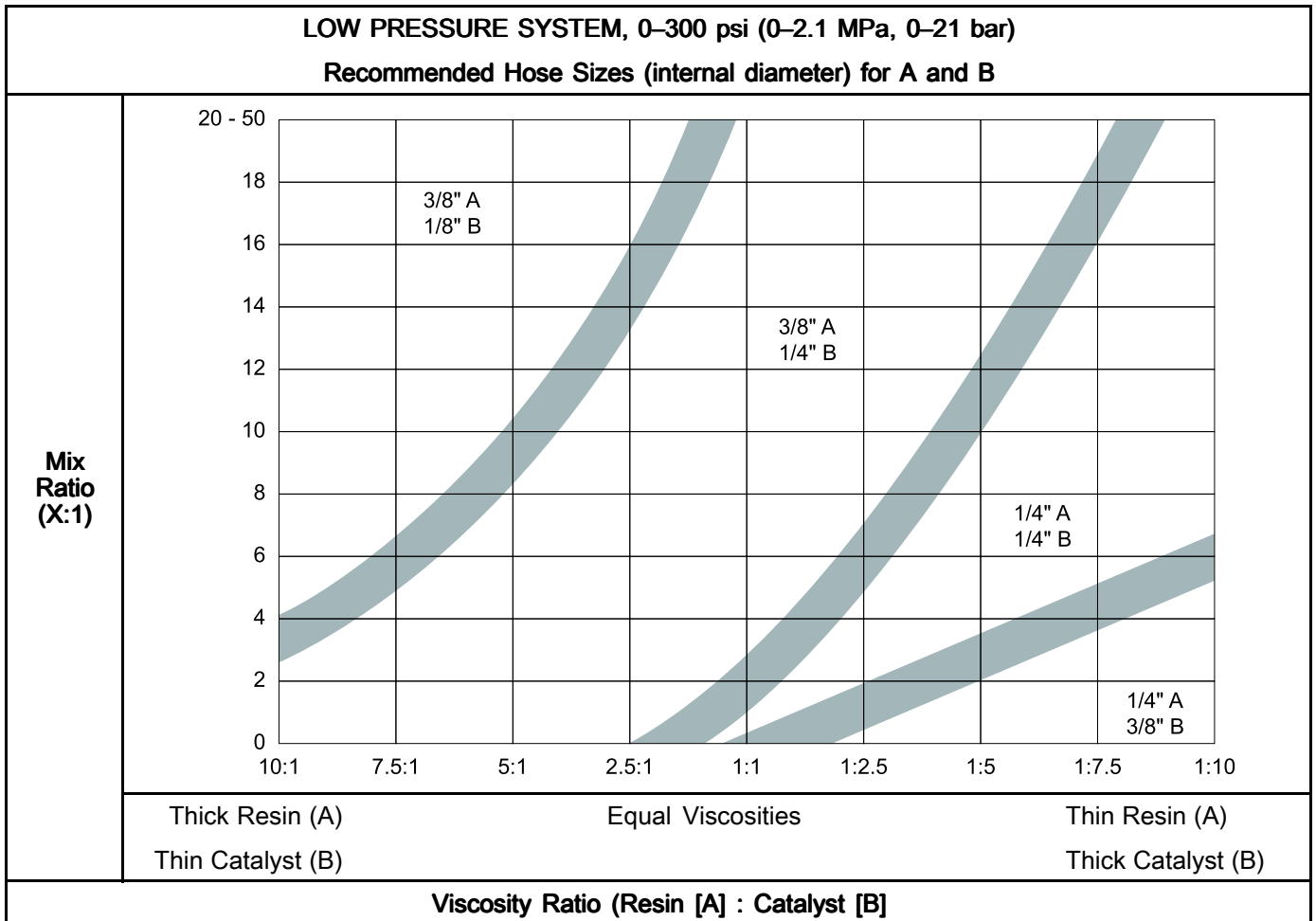

Additional Considerations for PD3K+ Systems**Step 1: Determine hardware requirements**

- Number of pumps (3–4 maximum)
 - A Pump (1 or 2)
 - B Pump (1 or 2)
 - C Pump (1 or 2)
- Pump size (35 cc or 70 cc)
 - The third component material ratio determines the pump size. Ratios less than 1 use a 35 cc pump, and ratios greater than 1 use a 70 cc pump.
- Materials plumbed to each pump (resin, catalyst, thinner, or color)
 - Pump #1 (A, B, or C material) — Typically for the resin material and the highest ratio volume.
 - Pump #2 (A, B, or C material) — Typically for the catalyst material and a lower ratio volume.
 - Pump #3 (A, B, or C material) — Typically for a thinner (solvent, water, activator, or promoter) and a wide variation in ratio volume.
 - Pump #4 — Typically for a dedicated color or a fourth component.
- Number of colors/materials on each pump
 - Number of A Pump color/material valves
 - Number of B Pump color/material valves
 - Number of C Pump color/material valves
 - Number of Pump #4 colors, if used

Step 2: Determine mix manifold configurations

- Mix-at-Wall 3K manifolds (manual or automatic system)
 - All three materials are combined at the same 3K Mix-at-Wall manifold.
- 2K manifolds; combining A and B (or A and C) first, then A+B to C (or A+C to B) prior to the spray gun. Some materials can be combined without a pot life, so only the material from the second manifold may need to be flushed. (Manual applications can use Mix-at-Belt and Mix-at-Wall. Automatic applications can use staged, 2K Mix-at-Wall manifolds.)
 - A and B materials combined first, and then C added (waterborne materials).

- A and C materials combined first, and then B added (solvent reduction for resin for viscosity control).
- Mix manifold locations are based on material chemistry, pot life, component viscosities, and material flush/waste considerations.

Step 3: Determine location of PD3K equipment around the spray booth

- Includes the proportioner, color stacks, and mix manifolds.
- Consider plumbing routing, and then determine the lengths of hosing needed to complete each section of the plumbing installation.

Step 4: Calculate line sizes

- Determine the individual component flow rates by spray gun flow and fluid mix ratios.
- Calculate the pressure loss to the first stage manifold for each component. Select line sizes to keep component pressure losses as close to each other as possible.
 - Pressure loss = (Constant x Viscosity x Flowrate x Distance)/ID⁴
 - Constant = 0.000273
 - Viscosity = CPS
 - Flowrate = GPM
 - Distance = feet
 - ID⁴ = Inside diameter of the hose to the 4th power
- Estimate the viscosity of material from the first stage by considering individual material viscosities and component ratios.
- Calculate the pressure losses for fluid lines to the second stage manifold. Include the line loss of the first hose, plus the mixer and hose loss between the first and second manifold.
- Calculate the final mixed material line loss from the second manifold to the spray gun.

Optimum line sizing lowers the overall spray pressures and minimizes significant transitional effects of flowrate changes.

1/4 in. (6 mm) ID Hoses

Application	Material	Pressure	Maximum Fluid Working Pressure	Length		
				15 ft (4.6 m)	25 ft (7.6 m)	50 ft (15.2 m)
Catalyst	Moisture-Lok	High and Low	2000 psi (13.8 MPa, 138 bar)	947078	24T134	24T135
	Nylon	Low	225 psi (1.6 MPa, 16 bar)	17C967	24T266	24T267
		High	4100 psi (28.3 MPa, 283 bar)	238825	239107	239111
Resin	Nylon	Low	225 psi (1.6 MPa, 16 bar)	17C967	24T266	24T267
		High	4100 psi (28.3 MPa, 283 bar)	238825	239107	239111
Solvent	Nylon	Low	225 psi (1.6 MPa, 16 bar)	17C967	24T266	24T267
		High	4100 psi (28.3 MPa, 283 bar)	238825	239107	239111
Atomizing Air	Nylon	Low	225 psi (1.6 MPa, 16 bar)	17C967	24T194	24T195

3. Select Remote Mix Manifold

The following remote mix manifold kits are available. The mix manifolds may be attached to the wall, in the hazardous area, allowing mixing to occur close to the point of spray. See the Color Change and Remote Mix Manifold Kits manual in [Related Manuals, page 2](#), for more information. The PD3K+ system may use more than one manifold, and/or a Three-port Wall Mounted Manifold.

Mix Manifold	Description	Maximum Fluid Working Pressure
25D543	Low Pressure Remote Mix Manifold	300 psi (2.1 Mpa, 21 bar)
25D605	High Pressure Remote Mix Manifold	1500 psi (10.5 Mpa, 105 bar)
26C288	Three-port Low Pressure Remote Mix Manifold	300 psi (2.1 Mpa, 21 bar)

NOTE: The 26C288 manifold is only used with the ProMix PD3K+ system. Additional flow switch

kits (24T787) may be necessary for additional components that need to be installed.

4. Select a Spray Gun

Spray Guns

Select an automatic spray gun from the following table.

Application	Gun Model	Gun Manual No.	Maximum Fluid Working Pressure
Conventional Air Spray	AirPro	313516	100 psi (0.7 MPa, 7 bar)
Electrostatic Air Spray	Pro Xs	309297	100 psi (0.7 MPa, 7 bar)
Conventional Air-Assisted Spray	G40	311052	4000 psi (28 MPa, 280 bar)
Electrostatic Air-Assisted Spray	Pro Xs AA	309298	3000 psi (21 MPa, 210 bar)

5. Select Color and Catalyst Change Control Module Kits

Using the following tables, choose color/catalyst change control module kits that meet your application's requirements. The kits include a control module with solenoid valves. See the Color Change Kits and Color Change and Remote Mix Manifold Kits manuals in [Related Manuals, page 2](#), for more information.

NOTE: All Color/Catalyst Control Module kits are to be mounted outside of the hazardous location only. If your application requires remote color change and the control modules be mounted in the hazardous location. See the Color Change and Remote Mix Manifold Kits manual in [Related Manuals, page 2](#), for legacy kits that include IS-approved control modules.

Table 1 Color/Catalyst Change Control Kits (300 psi [2.068 Mpa, 20.06 bar])

Kit Part No.	Kit Description
25D328	Control module with 4 solenoids
25D329	Control module with 5 solenoids
25D474	Control module with 6 solenoids
25D475	Control module with 7 solenoids
25D476	Control module with 8 solenoids
25D477	Control module with 9 solenoids
25D478	Control module with 10 solenoids
25D479	Control module with 11 solenoids
25D480	Control module with 12 solenoids
25D481	Control module with 13 solenoids
25D482	Control module with 14 solenoids
25D483	Control module with 15 solenoids
25D484	Control module with 16 solenoids
25D485	Control module with 17 solenoids
25D486	Control module with 18 solenoids

6. Select Color and Catalyst Change Manifold Kits

Using the following tables, choose color/catalyst change control manifold kits that meet your application's requirements. The kits include a manifold with valves. See the Color Change Kits and Color Change and Remote Mix Manifold Kits manuals in [Related Manuals, page 2](#), for more information.

Table 2 Low Pressure Color/Catalyst Change Manifold

Kit Part No.	Kit Description
Low Pressure Pumps Non-Circulating Kits	
24Y936	2 valve manifold
24Y938	3 valve manifold
24Y940	4 valve manifold
24Y942	5 valve manifold
24Y944	6 valve manifold
24Y946	7 valve manifold
24Y948	8 valve manifold
24Y950	9 valve manifold
24Y952	10 valve manifold
26A272	11 valve manifold
26A274	12 valve manifold
26A286	13 valve manifold
26A276	14 valve manifold
26A278	15 valve manifold
26A280	16 valve manifold
26A282	17 valve manifold
26A284	18 valve manifold
Low Pressure Circulating Kits	
24Y937	2 valve manifold
24Y939	3 valve manifold
24Y941	4 valve manifold
24Y943	5 valve manifold
24Y945	6 valve manifold
24Y947	7 valve manifold
24Y949	8 valve manifold
24Y951	9 valve manifold
24Y953	10 valve manifold
26A273	11 valve manifold
26A275	12 valve manifold
25A605	13 valve manifold
26A277	14 valve manifold
26A279	15 valve manifold

Configure Your System

Kit Part No.	Kit Description
26A281	16 valve manifold
26A283	17 valve manifold
26A285	18 valve manifold

Table 3 High Pressure Color/Catalyst Change Manifold

Kit Part No.	Kit Description
High Pressure Pumps Non-Circulating Kits	
24T647	2 valve manifold
24T648	3 valve manifold
24T649	4 valve manifold
24T650	5 valve manifold
24T651	6 valve manifold
24T652	7 valve manifold
24T653	8 valve manifold
24T654	9 valve manifold
24T655	10 valve manifold
24T656	11 valve manifold
24T657	12 valve manifold
24T658	13 valve manifold
24T659	14 valve manifold
24T660	15 valve manifold
24T661	16 valve manifold
24T662	17 valve manifold

Kit Part No.	Kit Description
24T663	18 valve manifold
High Pressure Acid Compatible Non-Circulating Kits	
24X360	2 valve manifold
24U182	3 valve manifold
24U183	4 valve manifold
High Pressure Circulating Kits	
24T677	2 valve manifold
24T678	3 valve manifold
24T679	4 valve manifold
24T680	5 valve manifold
24T681	6 valve manifold
24T682	7 valve manifold
24T683	8 valve manifold
24T684	9 valve manifold
24T685	10 valve manifold
24T686	11 valve manifold
24T687	12 valve manifold
24T688	13 valve manifold
24T689	14 valve manifold
24T690	15 valve manifold
24T691	16 valve manifold
24T692	17 valve manifold
24T693	18 valve manifold

7. Select Pump Expansion Kits

NOTE: These are not required for Acid systems which only use a single catalyst, or for Dual Panel systems since they already include four pumps.

The following table lists available kits to add a third or fourth pump to your system. Each kit includes one pump, a pump control module, solenoid, frame, mounting bracket, and cabling. See the Pump Expansion Kit manual (332456) for further information.

Kit Part No.	Kit Description
Low Pressure Pumps (300 psi [2.068 MPa, 20.68 bar])	
24R968	Low pressure resin 70cc pump
24R970	Low pressure catalyst 35cc pump
High Pressure Pumps (1500 psi [10.34 MPa, 103.4 bar])	
24R969	High pressure resin 70cc pump
24R971	High pressure catalyst 35cc pump

8. Select Communication Options

1. If your application requires integration with a PLC:
 - a. 24W829, CGM Kit for PD2K
26A303, CGM Kit for PD2K Dual Panel
26C284, CGM Kit for PD3K+
25D997, CGM Kit for PD2K Dual Panel with ProfiNet
 - b. CGMEP0, Ethernet IP
CGMDN0, Device Net
CGMPN0, ProfiNet*
24W462, Modbus TCP

* Two CGM modules included with 25D997, CGM Kit for PD2K Dual Panel with ProfitNet.
2. If your application requires AWI:
 - a. 24W829, CGM Kit for PD2K
 - b. 24W462, Modbus TCP**
 - c. 15V337, AWI Module

NOTE: AWI is not currently available for Dual Panel systems.

** AWI requires its own Modbus TCP module. If the PLC is also communicating over Modbus TCP, then two 24W462 modules are necessary.

9. Accessory Tool Kit

The following kit includes an assortment of tools for maintenance and repair of the PD2K system.

Kit Part No.	Kit Description
25D980	PD2K Maintenance Tool Kit

10. Upgrade Kit



The following kit includes software and parts to upgrade a ProMix PD2K to PD3K+.

Kit Part No.	Kit Description
26C416	PD3K+ Upgrade Kit

General Information

- Reference numbers and letters in parentheses in the text refer to numbers and letters in the illustrations.
- Be sure all accessories are adequately sized and pressure-rated to meet system requirements.
- To protect the screens from paints and solvents, clear-plastic protective shields (10 per pack) are available. Order Part No. 197902 for the Advanced Display Module. Clean the screens with a dry cloth if necessary.

Location

				
<p>To prevent tipping which can cause serious injury and equipment damage, the mounting stand must be securely anchored to the floor or to an appropriate base. The stand is not intended for free-standing use or wall mounting.</p>				

Mounting the PD2K Base Unit:

- Mount the PD2K in a non-hazardous location.
- Ensure that the mounting surface and mounting hardware are strong enough to support the weight of the equipment, fluid, hoses, and stress caused during operation.
- Do not mount to a wall.
- Secure the stand to the floor with 1/2 in. (13 mm) bolts which engage at least 6 in. (152 mm) into the floor to prevent the unit from tipping. See [Dimensions, page 52](#).
- There must be sufficient space on all sides of the equipment for installation, operator access, maintenance, and air circulation. The fans at the back of the unit require a minimum of 6 in. (152 mm) clearance from the closest surface to ensure adequate air circulation.

Install the Display Module

1. Use the screws (11) to mount the bracket (10) for the Advanced Display Module (12) on the front of the Control Box or on the wall.
2. Snap the Advanced Display Module into the bracket.

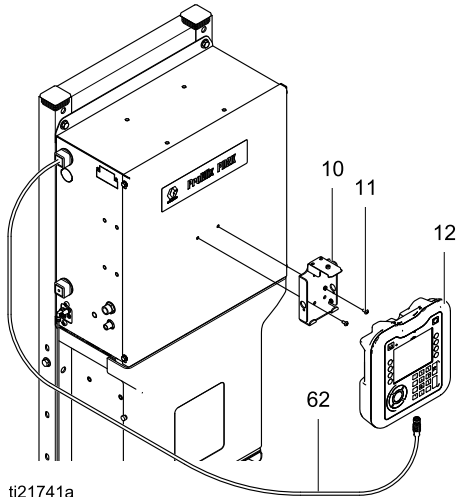

ti21741a

Figure 13 Install Display Module

3. Connect one end of the 5 ft (1.5 m) CAN cable (provided) to the Advanced Display Module (M). The other end of the cable comes from the factory connected to the Enhanced Fluid Control Module (EFCM).

NOTE: For a list of alternate cable lengths, see [Electrical Schematics, page 39](#). The total length of all cable used in the system must not exceed 150 ft (45 m).

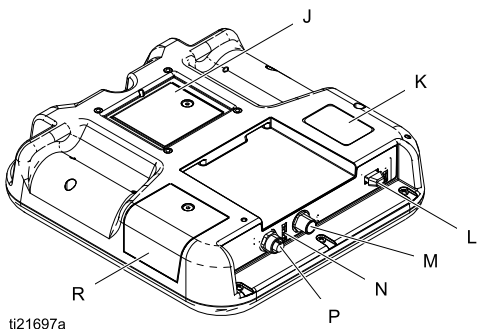

ti21697a

Figure 14 Advanced Display Module Connection Ports

Item	Description
J	Battery Cover
K	Model Number
L	USB Drive Interface
M	CAN Cable Connection
N	ADM Status LEDs
P	Accessory Cable Connection
R	Token Access Cover

Upgrade Software for ProMix PD3K+ System

If upgrading your ProMix PD system to a PD3K+, the software will need to be upgraded when starting up the system. The PD3K+ software comes on a black token with upgrade kit 26C416 (see [10. Upgrade Kit, page 23](#)).

Install the PD3K+ Upgrade Token

1. Shut off the PD2K power switch.
2. Remove the token access panel.

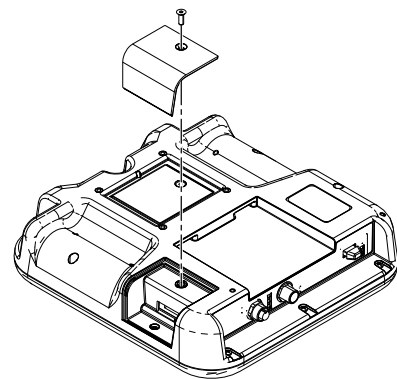

ti21699a

Figure 15 Remove Token Access Panel

3. Insert and press token (T) firmly into slot.

NOTE: There is no preferred orientation of the token.

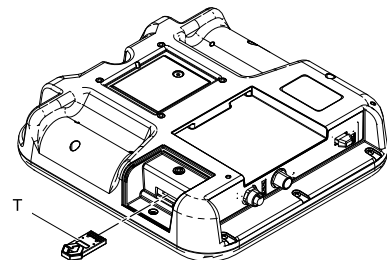

ti21700a

Figure 16 Insert Token

4. Turn the power switch back on. The red indicator light (L) will flash until the new firmware is completely loaded.
5. Remove the token (T).
6. Replace the token access panel.

Air Supply

Air Requirements

- **Compressed air supply pressure:** 85-100 psi (0.6–0.7 MPa, 6.0-7.0 bar).
- **Air hoses:** use grounded hoses that are correctly sized for your system.
- **Air regulator and bleed-type shutoff valve:** include in each air line to fluid supply equipment. Install an additional shutoff valve upstream of all air line accessories to isolate them for servicing.



Trapped air can cause a pump or dispense valve to cycle unexpectedly, which could result in serious injury from splashing or moving parts. Use bleed-type shutoff valves.



To reduce the risk of fire and explosion if using a Graco electrostatic gun, a shutoff valve must be installed in the gun air line to shutoff the atomizing and turbine air to the gun. Contact your Graco distributor for information on air shutoff valves for electrostatic applications.

- **Air Line Filter for System Control Air:** Use supplied air regulator/filter 17M842 to provide clean and dry air to system control solenoids.
- **Air Line Filter for Atomizing Air:** Provided by others to filter oil and water out of the air supply and help avoid paint contamination.

See [Technical Data, page 53](#), for air filtration requirements.

Air Connections

1. Tighten all system air and fluid line connections as they may have loosened during shipment.
2. Connect the main air supply line to air regulator/filter 17M842, and then to the main air inlet (136). This air line supplies the solenoids, valves, and pumps. Do not use this line to supply the gun's atomizing air.
3. Connect a **separate, dedicated**, clean air supply line to the air inlet of the gun atomizing air.

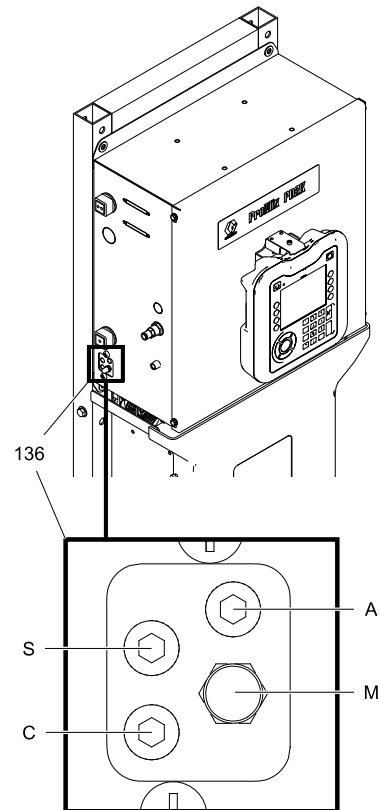





Figure 17 Atomizing Air and Air Manifold Connections Key

Connection	Description
A	Air inlet
C	Air cutoff output (plugged)
M	Exhaust muffler
S	Solvent cutoff output (plugged)

Fluid Supply

Fluid Requirements

				
<ul style="list-style-type: none"> To reduce the risk of equipment overpressurization and rupture which can cause injury, including skin injection, do not exceed the pressure rating of the lowest rated system component. See the identification label for the maximum working pressure of the equipment. To reduce the risk of injury, including skin injection, you must install a shutoff valve between each fluid supply line and the mix manifold. Use the valves to shut off fluid during maintenance and service. 				

Models are available to operate air spray (300 psi) or air-assisted (1500 psi) systems with a capacity of up to 800 cc/minute (depending on material viscosity).

- Fluid supply pressure tanks, feed pumps, or circulating systems can be used to supply fluid to the system.
- Materials can be transferred from their original containers or from a central paint recirculating line.

- Install a 100 mesh (minimum) fluid filter in the fluid supply line, with a drain valve.
- The supply line should be sized to avoid pressure loss of greater than a few psi between the circulation header and the proportioner fluid inlet port.

NOTE: The fluid supply must be free of pressure spikes, which are commonly caused by pump stroke changeover. Read the supply pressure on the gauge (P, see figure on next page). Supply capability for each pump must be at least 2 times the maximum operating flow rate. Supply pressure must be as close as possible to the pressure setpoint:

- For low pressure systems, ± 100 psi (0.7 MPa, 7 bar) of setpoint.

NOTE: For low pressure systems, it is recommended the supply pressure should be maintained at 1/2 to 2/3 of the system operating spray pressure.

- For high pressure systems, ± 300 psi (2.1 MPa, 21 bar) of setpoint.

If necessary, install pressure regulators or a surge tank on the pump fluid inlet lines to reduce pulsation. Contact your Graco distributor for additional information.

Single Color Connections

NOTE: Check valves (J, L) are provided on the inlet (K) and outlet (H) manifolds of each pump.

1. Connect the color supply line to the pump fluid inlet fitting (S).
2. Connect the color outlet line to the pump fluid outlet fitting (R).
3. Make the same connections on the catalyst side.

NOTE: For isocyanate catalyst materials, moisture resistant hose is required to supply fluid to the system and also as a fluid line between the pump and the mix manifold.

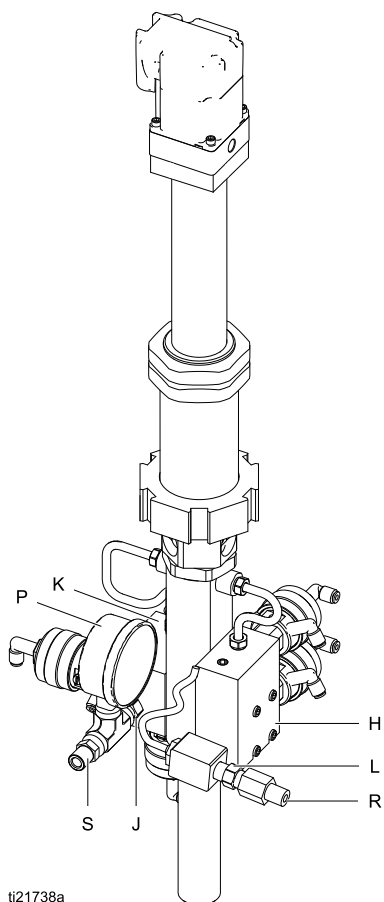

ti21738a

Figure 18 Pump Inlet and Outlet Connections

Color Change Connections

If you are installing the color change accessory kit, make the fluid connections as described in manual 333282.

Solvent Connections

1. Connect the solvent supply line for the resin to the inlet fitting (17) for solvent flow switch 1 (FS1).
2. Connect the solvent supply line for the catalyst to the inlet fitting (17) for solvent flow switch 2 (FS2).
3. Connect the solvent outlet line for the resin to the solvent flow switch 1 (FS1) outlet fitting (74) and then to the appropriate remote color change valve.
4. Connect the solvent outlet line for the catalyst to the solvent flow switch 2 (FS2) outlet fitting (74) and then to the appropriate remote color change valve.

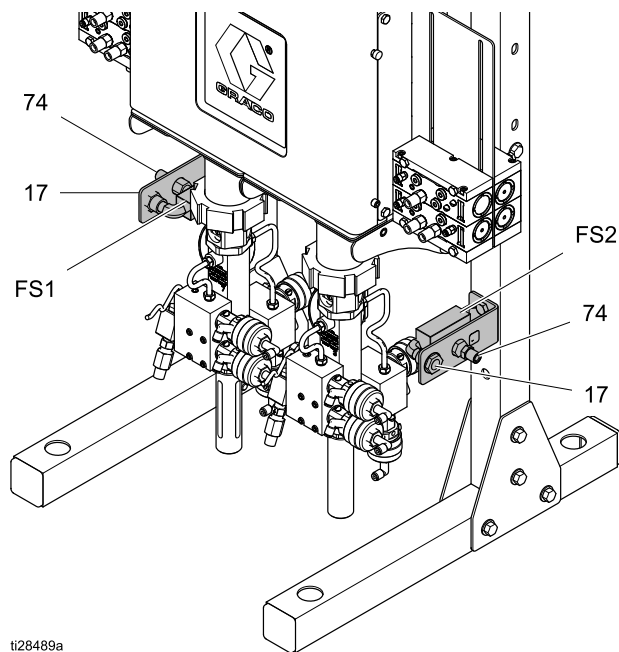

ti28489a

Figure 19 Solvent Connections

Dual Panel Solvent Connections

1. Connect the solvent supply line for the resin for Mix Unit #1 to the inlet fitting (17) for solvent flow switch 1 (FS1).
2. Connect the solvent supply line for the catalyst for Mix Unit #1 to the inlet fitting (17) for solvent flow switch 2 (FS2).
3. Connect the solvent outlet line for the resin Mix Unit #1 to the solvent flow switch 1 (FS1) outlet fitting (74) and then to the appropriate remote color change valve.
4. Connect the solvent outlet line for the catalyst Mix Unit #2 to the solvent flow switch 2 (FS2) outlet fitting (74) and then to the appropriate remote color change valve.
5. Repeat steps 1–4 for Mix Unit #2 using solvent flow switch 3 (FS3) and solvent flow switch 4 (FS4) for resin and catalyst supply lines, respectively.

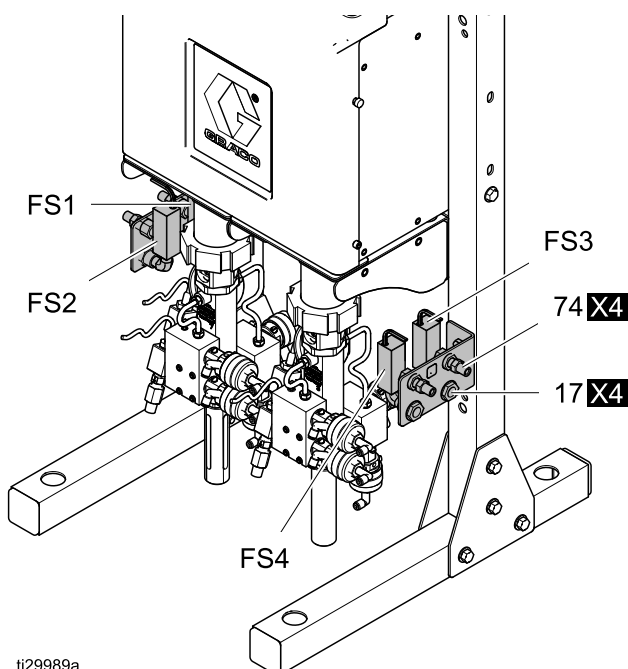

ti29989a

Figure 20 Dual Panel Solvent Connections

PD3K+ Solvent Connections

1. Connect the solvent supply line for component A to inlet fitting (17) for solvent flow switch 1 (FS1).
2. Connect the solvent supply line for component B to inlet fitting (17) for solvent flow switch 2 (FS2).
3. Connect the solvent supply line for component C to inlet fitting (17) for solvent flow switch 3 (FS3).
4. Connect the solvent supply line for component D to inlet fitting (17) for solvent flow switch 4 (FS4).
5. Connect the solvent outlet line for component A to the solvent flow switch 1 (FS1) outlet fitting (74) and then to the appropriate remote color change valve.
6. Connect the solvent outlet line for component B to the solvent flow switch 2 (FS2) outlet fitting (74) and then to the appropriate remote color change valve.
7. Connect the solvent outlet line for component C to the solvent flow switch 3 (FS3) outlet fitting (74) and then to the appropriate remote color change valve.
8. Connect the solvent outlet line for component D to the solvent flow switch 4 (FS4) outlet fitting (74) and then to the appropriate remote color change valve.
9. Connect flow switch wires to the terminals as shown in the table below.

Solvent Flow Switch 1: Component A Remote Solvent	EFCM Connector J6 Pins 11-12
Solvent Flow Switch 2: Component B Remote Solvent	EFCM Connector J7 Pins 9-10
Solvent Flow Switch 3: Component C Remote Solvent	EFCM Connector J6 Pins 7-8
Solvent Flow Switch 4: Component D Remote Solvent	EFCM Connector J6 Pins 9-10

TSL Cup Kit

The cup is used for either Throat Seal Liquid (TSL) or ISO oil. These liquids prevent exposure of air or moisture with the resin or catalyst at the pump throat packings and dosing valves. The PD2K Proportioner includes two TSL Cup Kits, one for each pump. The cups supply TSL to the upper throat cartridge of the color (70 cc) pump, to the upper and lower throat cartridges of the catalyst (35 cc) pump, and to the four pump dosing valves. When using isocyanate catalysts, the cup attached to the catalyst side of the PD2K Proportioner is used to supply ISO oil to the upper and lower throat cartridges of the catalyst (35 cc) pump and the catalyst dosing valves.

NOTE: TSL and ISO oil must be ordered separately. For TSL, order Part No. 206995, one quart (0.95 liter). For ISO oil, order Part No. 217374, one pint (0.48 liter).

1. Slide the kit mounting bracket onto any side of the pump's hex nut.

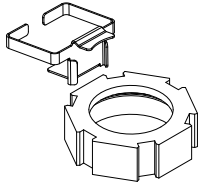

NOTE: Prior to mounting the cup, use a permanent black marker to mark a horizontal line on the front of the cup approximately half way between the top and bottom of the cup. Mark a second horizontal line approximately 1/4 in. (3 mm) above the first line. Shining a strong light towards these lines will provide a shadow that will be visible from inside the TSL cup.

2. Place the TSL cup (73) into the bracket (73a).

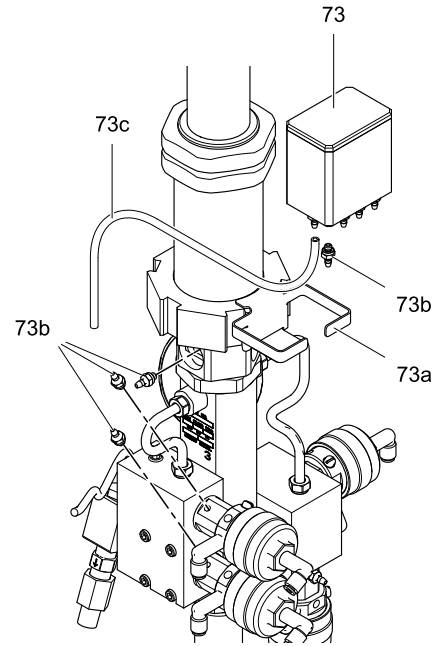
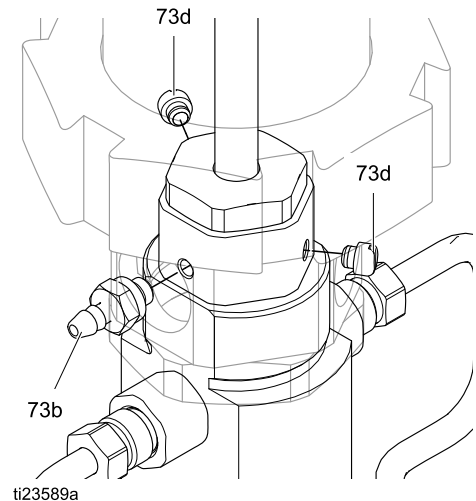

Figure 21 Install TSL Cup Kit

NOTE: The pump's upper throat cartridge has three ports (two are plugged). Move a plug (73d) if necessary so the barbed fitting (73b) can be put in the port closest to the TSL cup.

3. Check that the o-ring is in place on the barbed fitting (73b). Apply low strength thread adhesive and install the fitting in the upper throat cartridge port. Be sure the other two ports are plugged (73d).



4. Repeat for the lower throat cartridge.

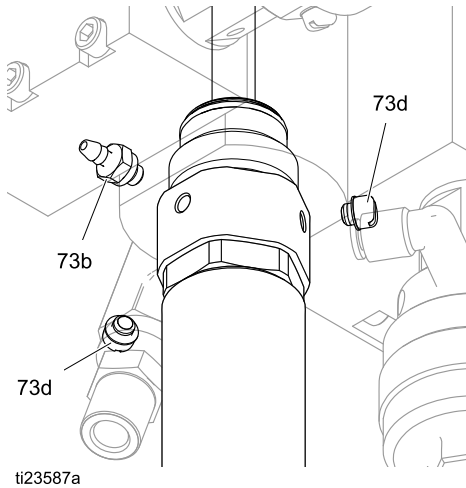

5. If you are lubricating the dosing valves, remove the plug (73d) and gasket from the valve port (V) closest to the TSL cup.

NOTE: Choose the valve port in the upward facing position. This will allow liquid to flow into the valve while allowing air to rise out of the valve.

Check that the o-ring is in place on the barbed fitting (73b). Apply low strength thread adhesive and install the fitting in the valve port (V).

NOTE: Do not confuse the valve port (V) with the air port (W).

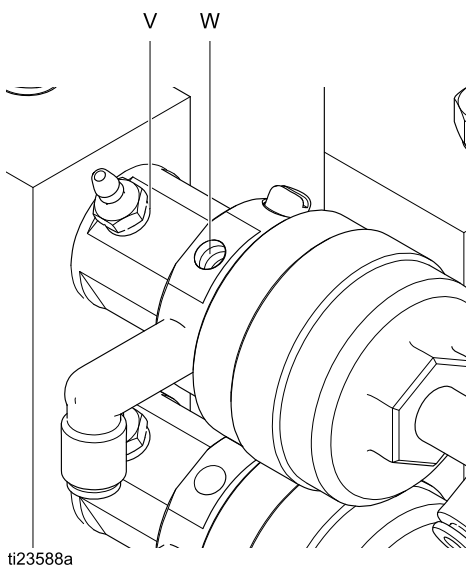

NOTE: If you are not lubricating the dosing valves, remove the unused barbed fittings (73b) from the bottom of the TSL cup (73). Apply low strength thread adhesive and install the plugs and gaskets supplied with the kit.

6. Cut the tubing (73c) to length as required. Connect the TSL cup fittings to the fittings on the pump and valves. TSL is gravity-fed from the cup to the pump and valves; position the fittings and tubing to prevent kinks and enable the TSL to flow freely down to the valve and air to rise up and out of the valve.

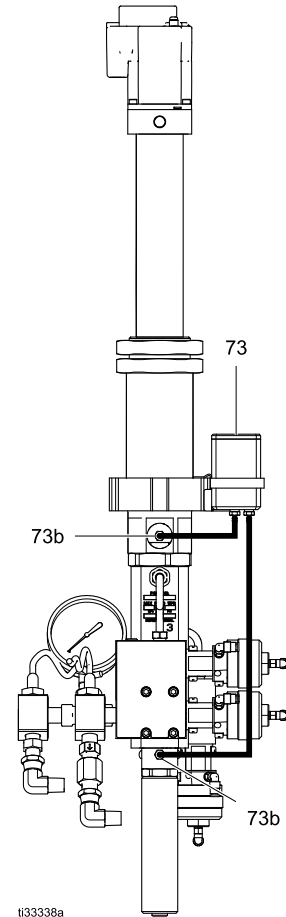

7. Fill the cup to the level of the lower black horizontal line with either TSL or ISO oil, as appropriate for the resin and catalyst materials being used.

NOTE: If TSL leaks from the rod guard of the color (70 cc) pump, be sure the lower u-cup seal is installed in the lower throat cartridge.

NOTE: The fluid levels in the TSL cups should be checked daily. Fluid levels should remain static for an extended period of time. Rising or falling fluid levels in a TSL cup can be an indication of a condition which needs immediate attention. Refer to the troubleshooting steps in the repair manual for guidance.

ISO Oil Fill Procedure

When using polyurethane coatings with isocyanate catalysts in high-humidity environments, use of ISO oil on the catalyst pump TSL cup is recommended instead of TSL. The ISO oil will present a barrier that will prevent catalyst hardening from contact with moisture. When performing the first fill of a cup with ISO oil, it will be necessary to bleed the air out of the feed line.

NOTE: If not already present on the TSL cup, draw the two horizontal lines at, and slightly above, the vertical center of the front of the cup before filling.

To bleed air:

1. Fill the catalyst pump TSL cup to the lower horizontal line.
2. Remove one plug (73d) from the upper throat cartridge and allow air in that area to flow until no air is being expelled. Replace the plug.
3. Repeat step 2 at the lower throat cartridge.
4. Use absorbent rags to clean up excess ISO oil that escaped from the plug holes.
5. Replenish the ISO oil level in the TSL cup to the lower horizontal line.

Alternate TSL Plumbing for Highly-Reactive/Moisture-Sensitive ISO Catalyst PD2K Pumps

NOTE: Graco recommends this alternate TSL (Throat Seal Liquid) plumbing installation only on Catalyst pumps, as the open rod guard of resin pumps does not generate TSL displacement.

The alternate TSL plumbing of the Catalyst pump allows TSL to flow through the upper seal and bearing cartridge by using the rod guard and lower-rod displacement. This flow purges isocyanate- and moisture- contaminated TSL from the throat area; preventing the crystallization reaction of the isocyanate and moisture from accumulating and damaging the pump seals, displacement rod, and bearings.

1. Replace a plug (73d) with a barbed fitting (73b) on a second port of the pump's upper throat cartridge (only one will be plugged). Check that the o-ring is in place on the barbed fitting (73b). Apply low-strength thread adhesive and install the fitting in the upper throat cartridge port. Be sure the third port is plugged (73d).

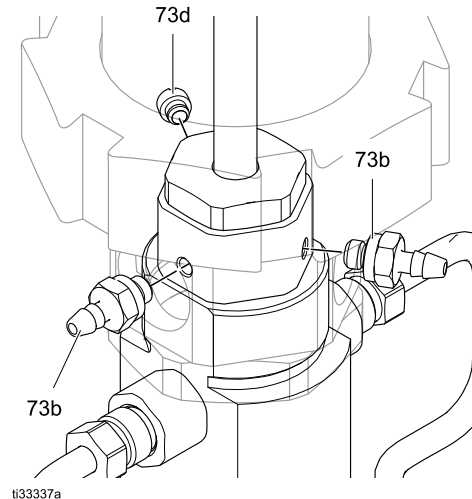

2. Connect the tubing (73c1) from the barbed fitting (73b) on the lower throat cartridge to one of the barbed fittings (73b) on the upper throat cartridge.* Connect tubing (73c2) from the other barbed fitting (73b) on the upper throat cartridge to a TSL cup fitting.

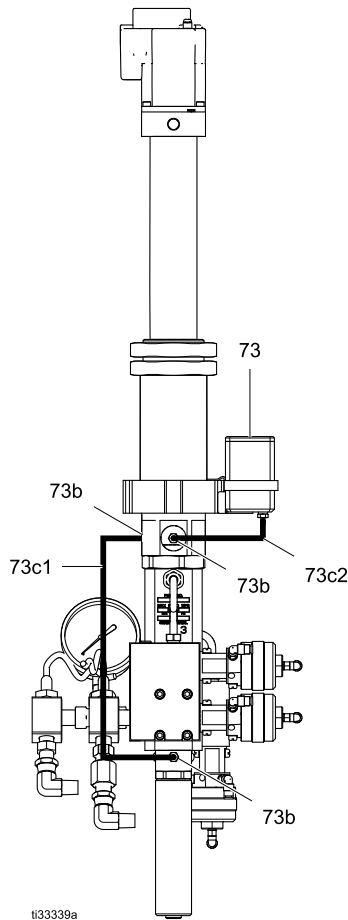

* No additional fittings or tubing are needed for the alternate TSL plumbing if the barb fitting (73b) from the TSL cup (73) and the second plug (73d) from the throat cartridge are used by swapping their positions.

Additional Maintenance and Precautions

The TSL fluid in the TSL reservoir must be replaced more frequently when the alternate TSL plumbing is used. This requirement prevents contaminated TSL from accumulating in the reservoir, causing fluid line contamination and increased pressure in the TSL tubes due to thickening viscosity. The TSL replacement frequency is determined by a number of factors: Catalyst reactivity, temperature and humidity of the pump environment, and seal wear condition. In severe environmental conditions, the TSL can require weekly replacement.

Another maintenance procedure that extends pump life is bleeding the fresh TSL into the rod guard during TSL replacement. This bleed process ensures that all of the air is removed from the guard and bearing cartridge, eliminating wet air contamination during the TSL replacement process.

1. Remove and thoroughly clean the rod guard.
2. Refill the rod guard with fresh TSL.
3. Place the rod guard over the rod.
4. Fill the Reservoir, and let gravity fill the TSL lines.
5. Thread the guard back on to the pump when the TSL begins to overflow the guard.

NOTICE

The rod guard displacement-flow volume through the bearing and barb fittings of the upper cartridge during high-cycle rates of the pump, or from filling and the color change process, can create fluid pressure in the TSL line between the pump's lower and upper cartridges. Route and anchor the TSL lines to prevent equipment damage if the lines develop leaks or separate from a barb fitting.

NOTICE

The TSL lines are flexible, clear, and compatible with TSL. These features make installation much easier, and allow for visual feedback of the TSL condition. The TSL tubing should be replaced to prevent equipment damage from tubing fluid compatibility failure if the lines become contaminated with catalyst material for extended periods of time.

Solvent Meter Accessory

To install Solvent Meter Kit 280555, see manual 308778.

NOTE: Install the solvent meter downstream of the solvent cutoff switch near the base unit.

Light Tower Accessory

To install Light Tower Kit 24K337, see manual 3A1906.

Electrical Supply

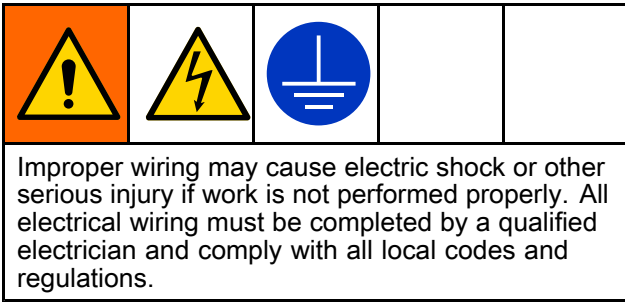

Electrical Requirements

Enclose all cables routed in the spray booth and high traffic areas in conduit to prevent damage from paint, solvent, and traffic.

The unit operates with 90-250 VAC, 50/60 Hz input power, with a maximum of 7 A current draw. The power supply circuit must be protected with a 15 A maximum circuit breaker.

- A power supply cord compatible to your local power configuration is not included. Wire gauge size must be 8-14 AWG.
- The input power access port is 22.4 mm (0.88 in.) in diameter. A strain relief is provided which accepts a cord diameter of 0.157–0.354 in. (4–9 mm). If another cord size is used, a user-supplied, appropriate size strain relief must be installed.

Electrical Connections

See [Electrical Schematics, page 39](#).

1. Verify that electrical power at the main panel is shut off. Open the Control Box cover.
2. Thread the electrical cord wires through the strain relief (S).
3. Connect the wires (L, N, G) securely to the corresponding terminals of the terminal block (T), as shown.
4. Tighten the strain relief nut securely.
5. Close the Control Box. Restore power.
6. Follow instructions in [Grounding, page 37](#).

Wire Key

Wire	Description
L	Line Power
N	Neutral
G	Ground

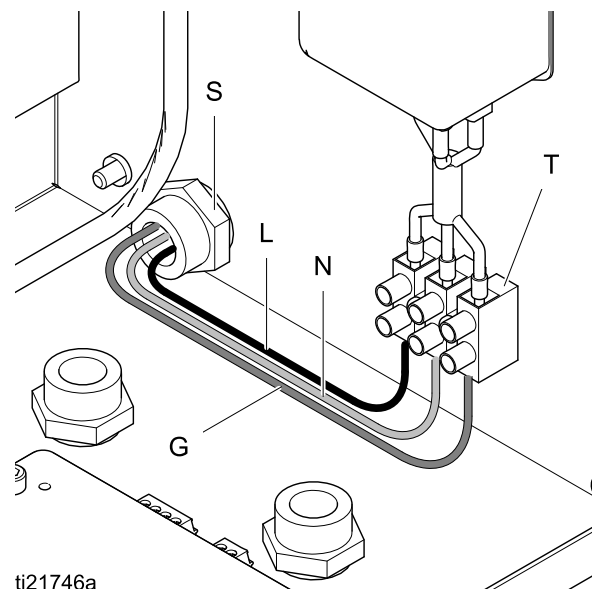

Figure 22 Control Box Electrical Connection

Field Bus Connections

If used, connect the ethernet cable to the CGM as applicable. Connect the other end of the cable to the FieldBus device.

NOTE: Connect the CGM to the FieldBus per FieldBus standards. The Modbus TCP interface operates at 100 MBit, full duplex. The interface is auto polarity sensing and auto-crossover capable.

1. Locate fitting (F) on the Electrical Control Box.

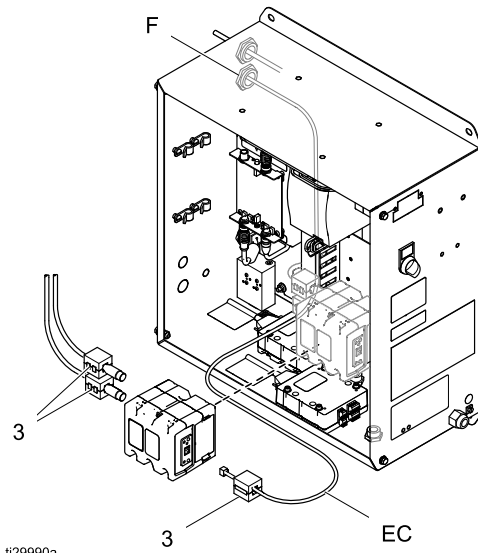

2. Remove the nut on fitting (F).
3. Remove the fitting far enough to allow disassembly of the fitting and to open the grommet.
4. Route FieldBus cable (EC) through the left wireway up to the grommet. Ensure that the ethernet cable is inserted with enough length to allow for routing within the box and for connection to the CGM.
5. Insert the FieldBus cable into the grommet hole and insert the grommet into the fitting.
6. Insert the fitting through the Electrical Control Box wall and install the nut. Tighten finger tight.
7. Attach a ferrite (3) near the end of the FieldBus cable.

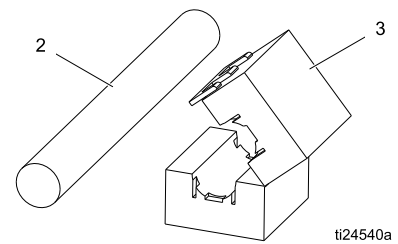

8. Attach the FieldBus cable to the CGM.

Grounding

See illustration on next page.

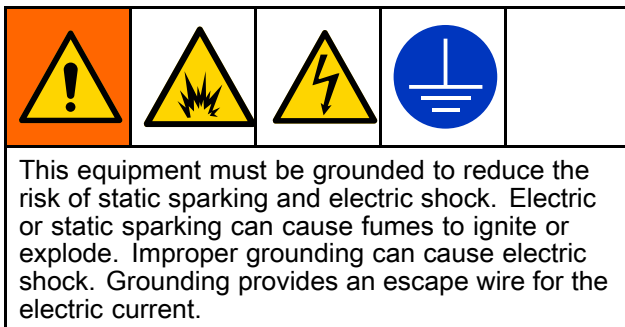

Electrical Control Box

The electrical control box has two ground points. Both connections must be made.

- Connect the ground wire (Y) to the ground screw on the electrical control box. Connect the clamp end to a true earth ground.
- The power supply must be grounded according to local codes. Connect the power supply ground wire to the Ground terminal in the electrical control box. See [Electrical Connections, page 35](#).

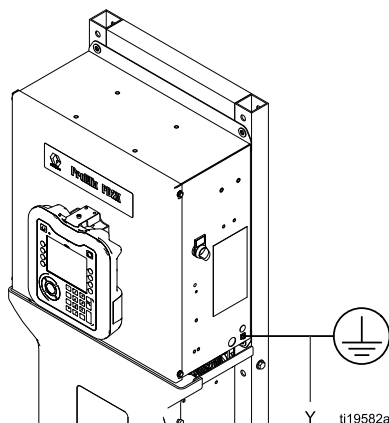

Figure 23 Ground Screw and Power Switch

Fluid Supply Container

Follow local code.

Color Change Module

Connect a ground wire from the color change module to a true earth ground.

Intrinsically safe color change modules located in the hazardous area must be connected to a true earth ground in the hazardous area.

Feed Pumps or Pressure Pots

Connect a ground wire and clamp from a true earth ground to the pumps or pots. See pump or pressure pot manual.

Air and Fluid Hoses

Use grounded hoses only.

Object Being Sprayed

Follow local code.

Solvent Reservoir or Purge Station

Follow local code. Use only a conductive solvent reservoir or purge station placed on a grounded surface. Do not place the solvent reservoir or purge station on a nonconductive surface, such as paper or cardboard, which interrupts the grounding continuity.

Check Resistance

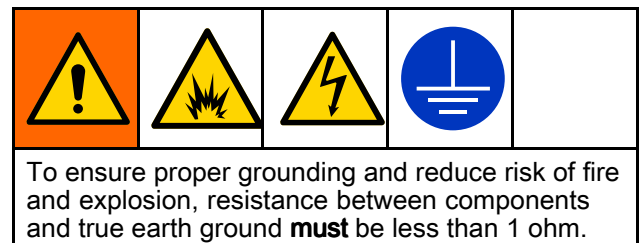

Spray Gun

Follow the grounding instructions in your gun manual.

- **Non-Electrostatic:** Ground the spray gun through connection to a Graco-approved grounded fluid supply hose.
- **Electrostatic:** Ground the spray gun through connection to a Graco-approved grounded air supply hose. Connect the air hose ground wire to a true earth ground.

HAZARDOUS LOCATION

NON-HAZARDOUS LOCATION

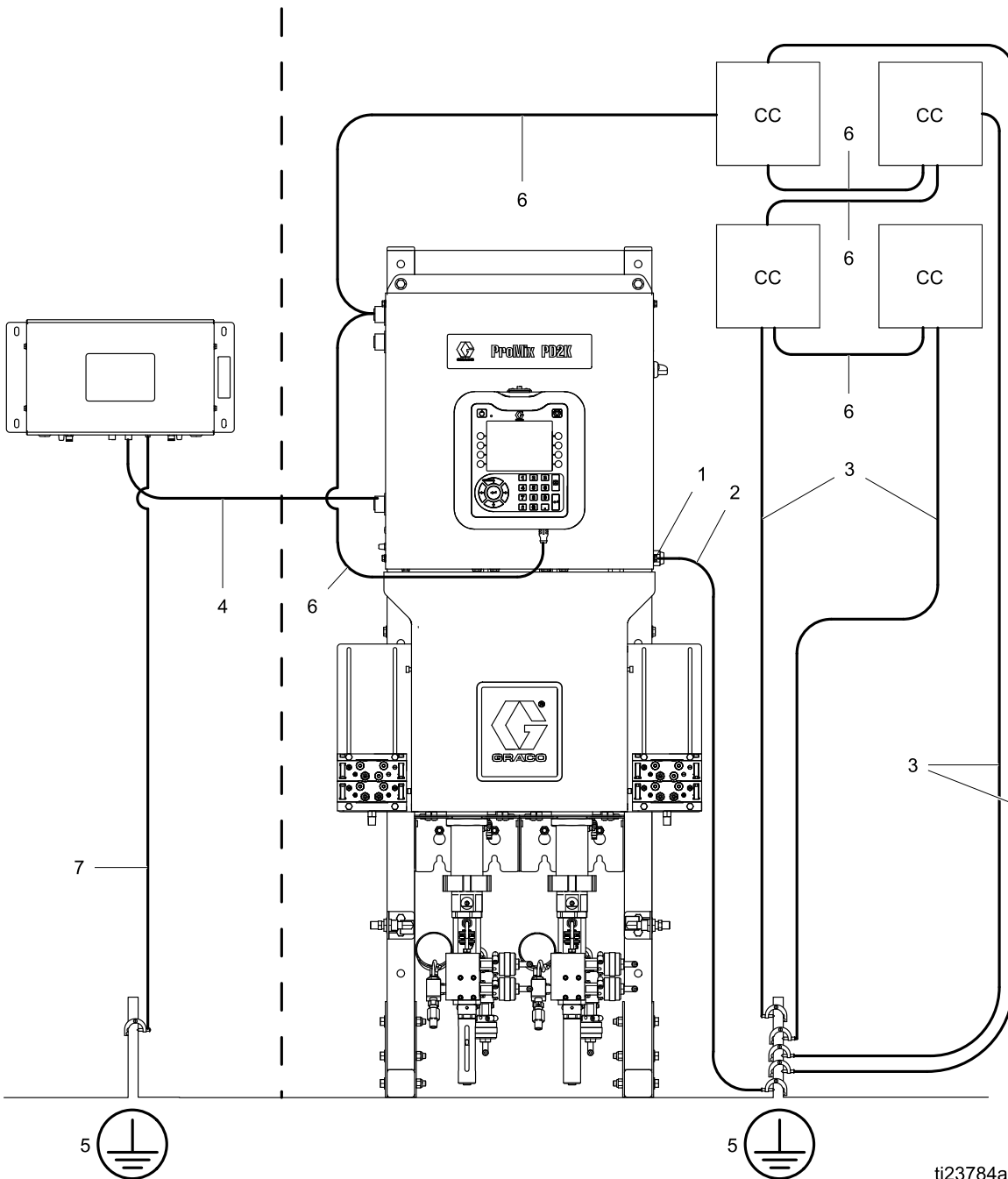

ti23784a

Figure 24 System Grounding

Key

1	Electrical Control Box ground screw
2	Electrical Control Box ground wire
3	Color Change Module (CC) ground wires
4	Intrinsically Safe (IS) cable

5	True Earth Ground; check local code for requirements
6	Non-Intrinsically Safe cable
7	Remote Mix Control Module ground wire

Electrical Schematics

Standard Models (AC1000, AC2000, AC3000, AC4000)

NOTE: The electrical schematic illustrates all possible wiring expansions in a ProMix PD2K system; models AC1000 and AC2000. Some components shown are not included with all systems.

NOTE: See [Optional Cables and Modules, page 51](#) for a list of cable options.

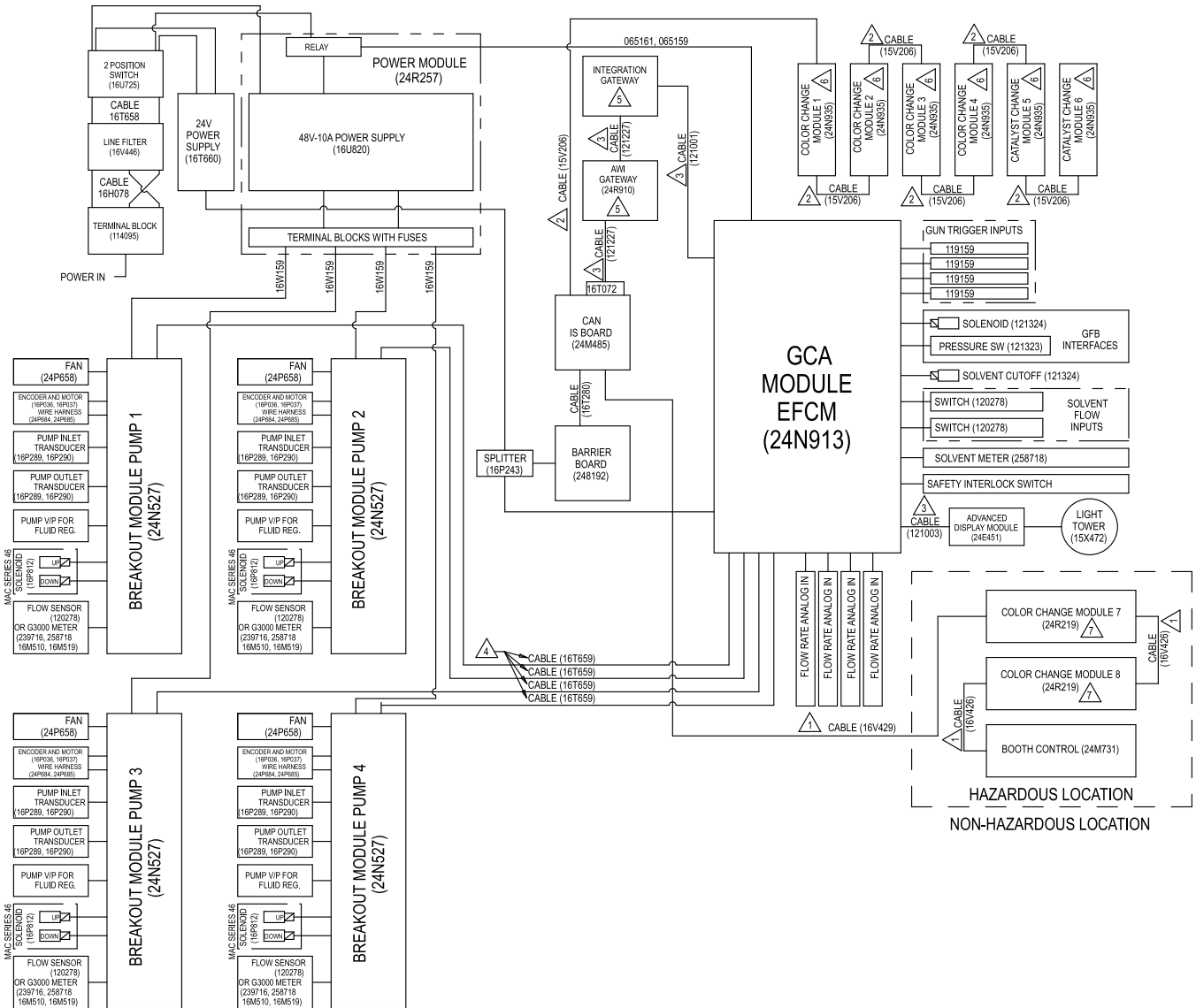

Figure 25 Electrical Schematic, Sheet 1

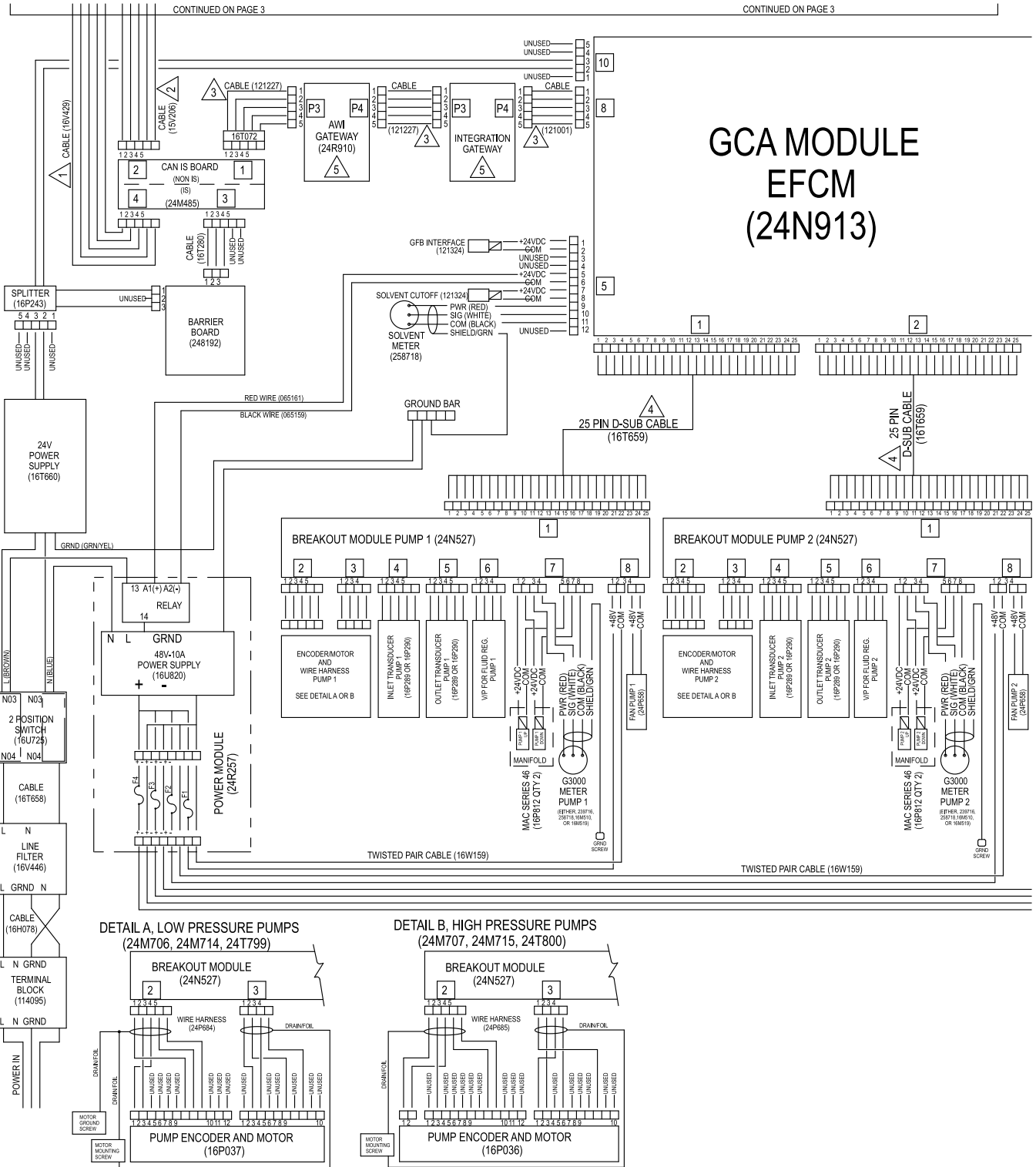

Figure 26 Electrical Schematic, Sheet 2, Part 1

CONTINUED ON THE NEXT PAGE

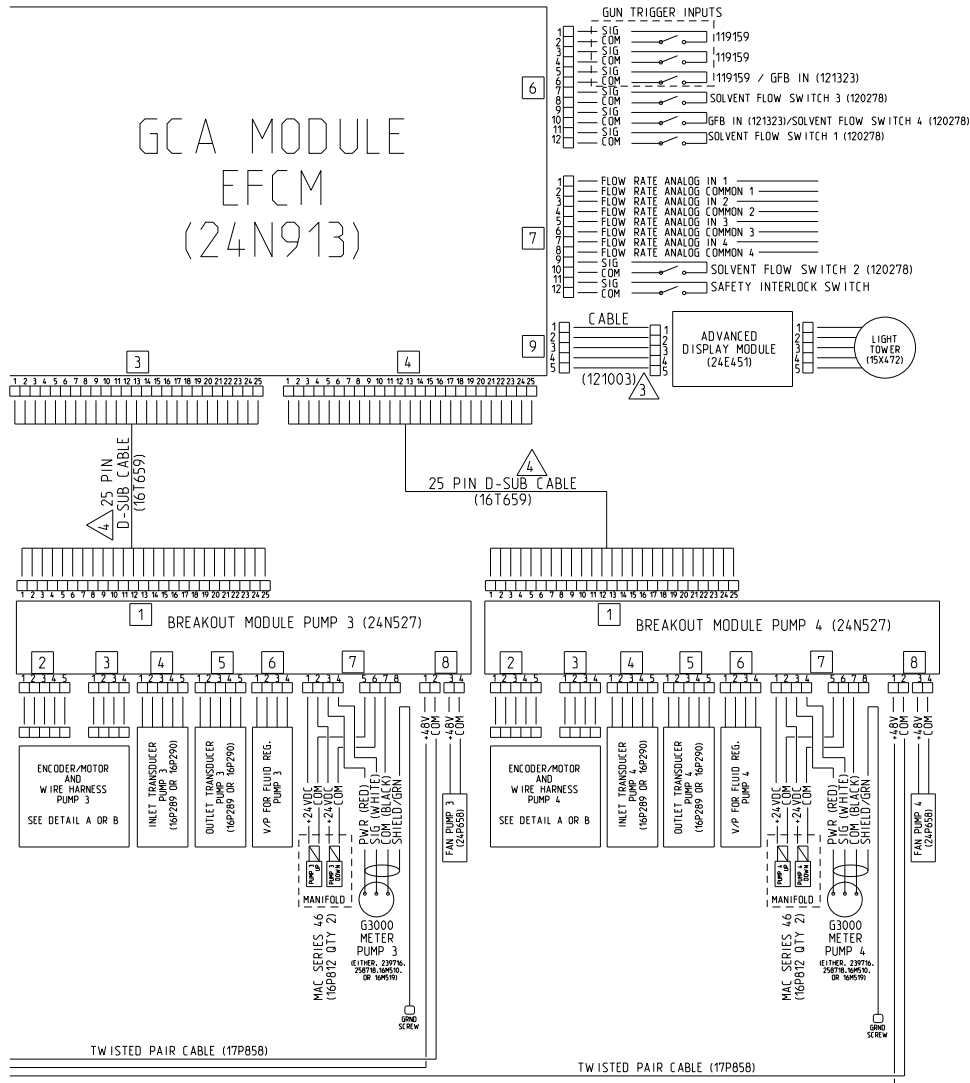

Figure 27 Electrical Schematic, Sheet 2, Part 2
CONTINUED ON THE NEXT PAGE

Electrical Schematics

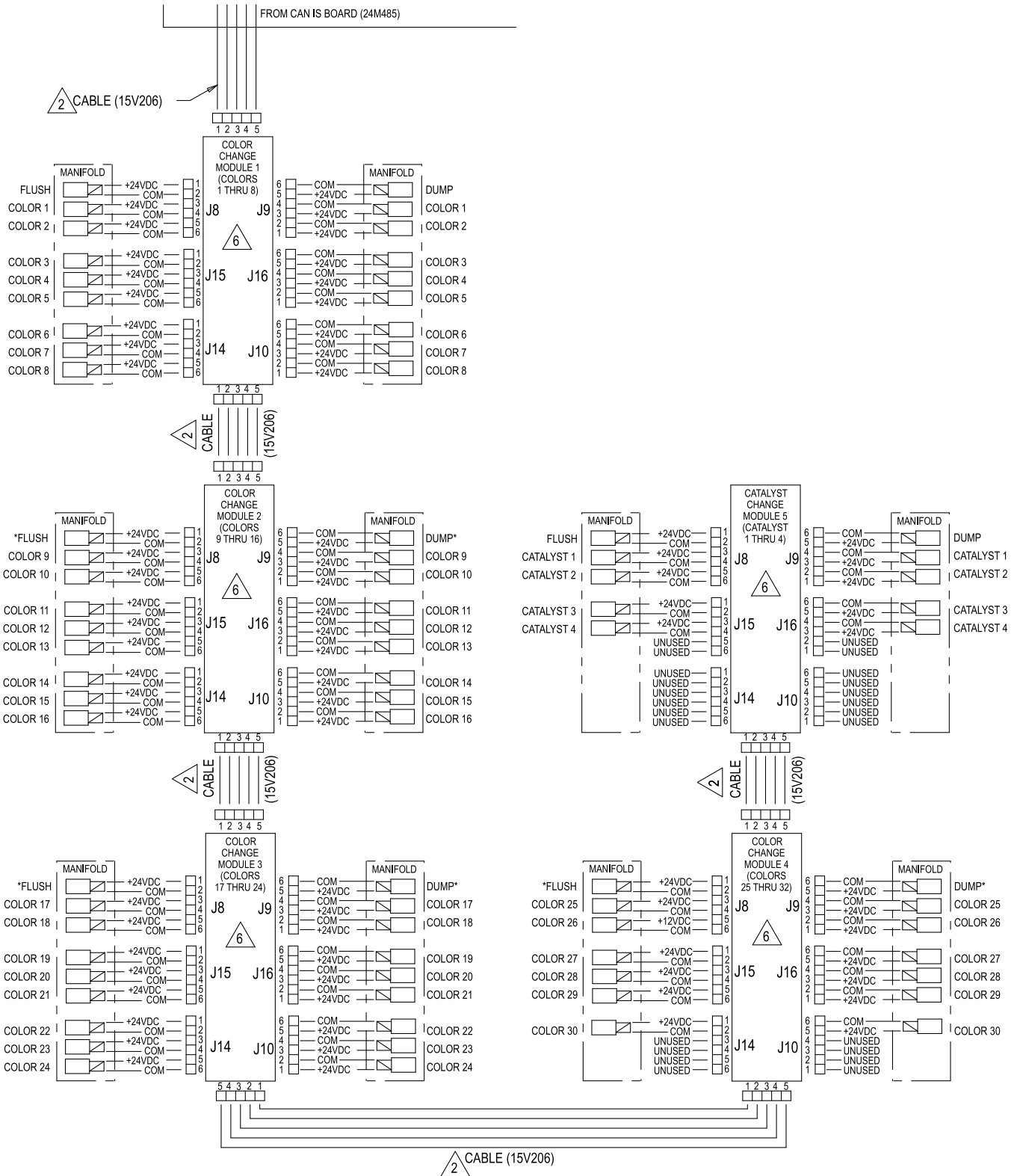
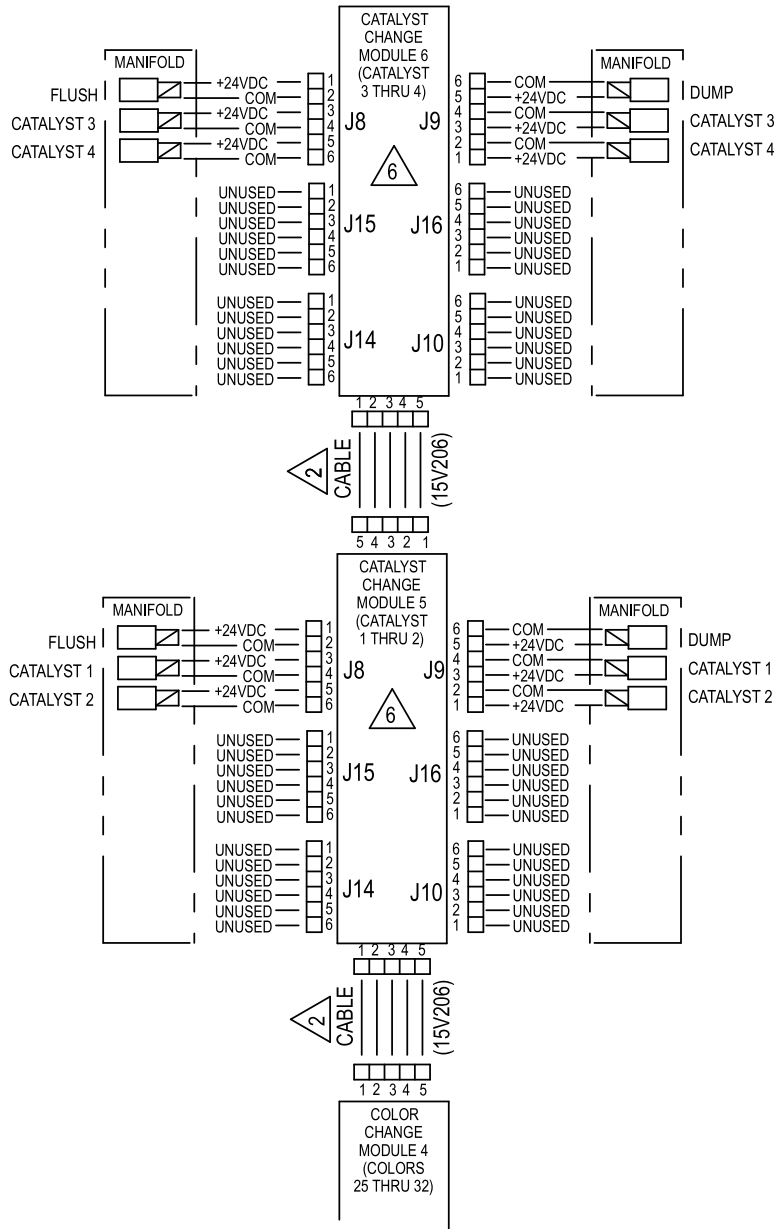

Figure 28 Electrical Schematic, Sheet 3

* May be unused in some configurations.

CONTINUED ON THE NEXT PAGE



ALTERNATE CONFIGURATION
FOR CATALYST CHANGE CONTROL

Figure 29 Electrical Schematic, Sheet 3, Alternate Configuration for Catalyst Change Control

CONTINUED ON THE NEXT PAGE

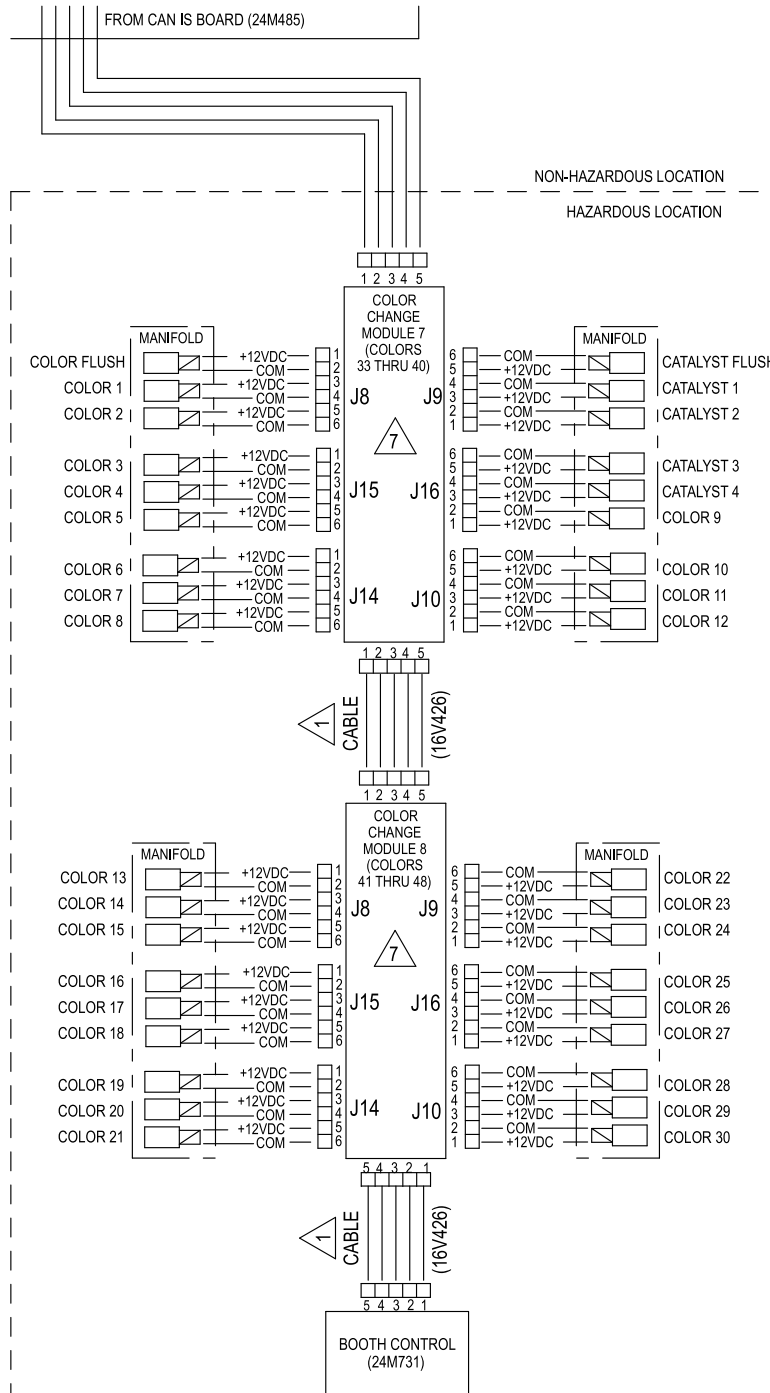

Figure 30 Electrical Schematic, Sheet 3, Hazardous Location

Dual Panel Models (AC1002, AC2002, AC3002, AC4002)

NOTE:The electrical schematic illustrates all possible wiring expansions in a ProMix PD2K system; models AC1002 and AC2002. Some components shown are not included with all systems.

NOTE: See [Optional Cables and Modules, page 51](#) for a list of cable options.

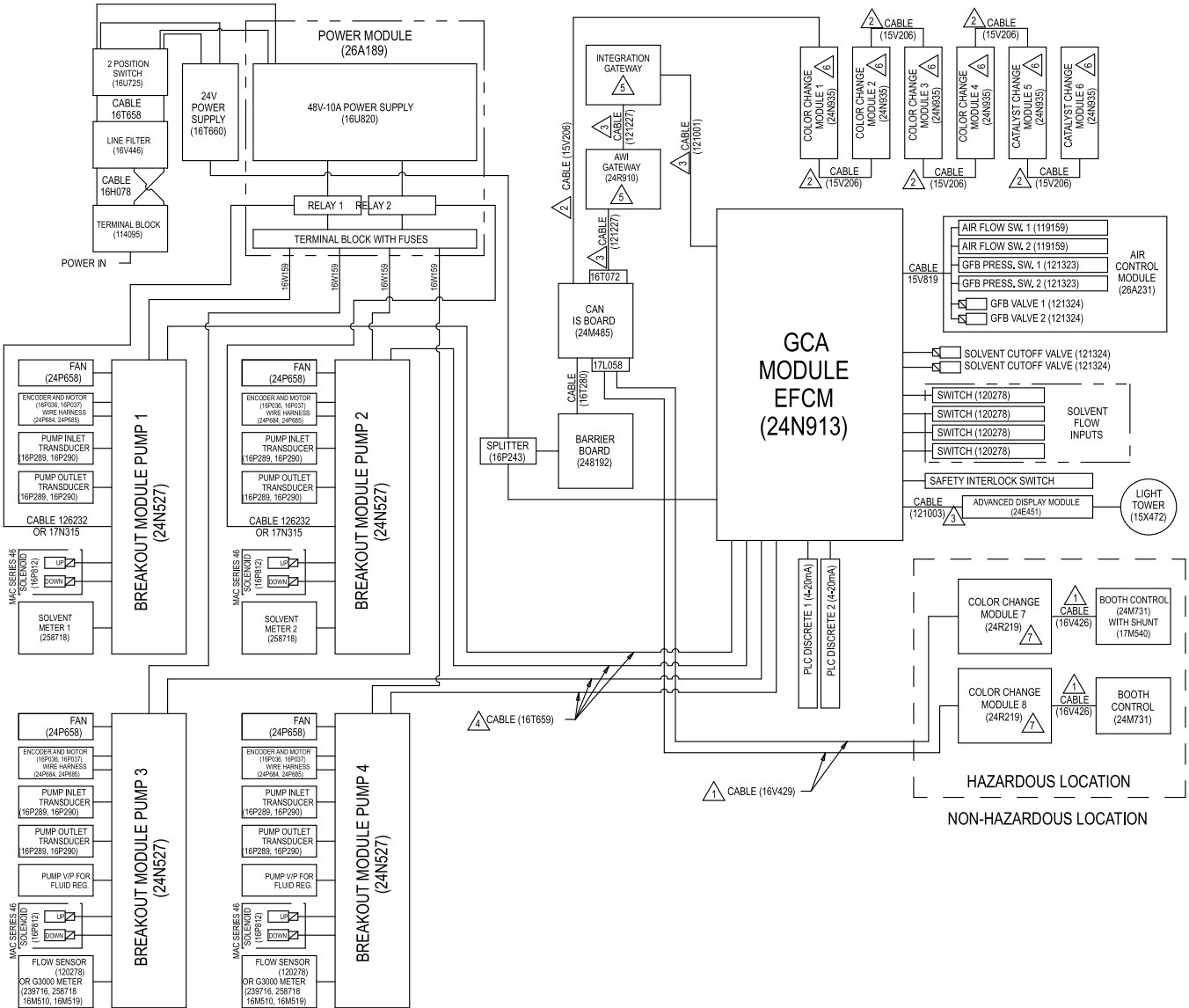

Figure 31 Electrical Schematic, Sheet 1

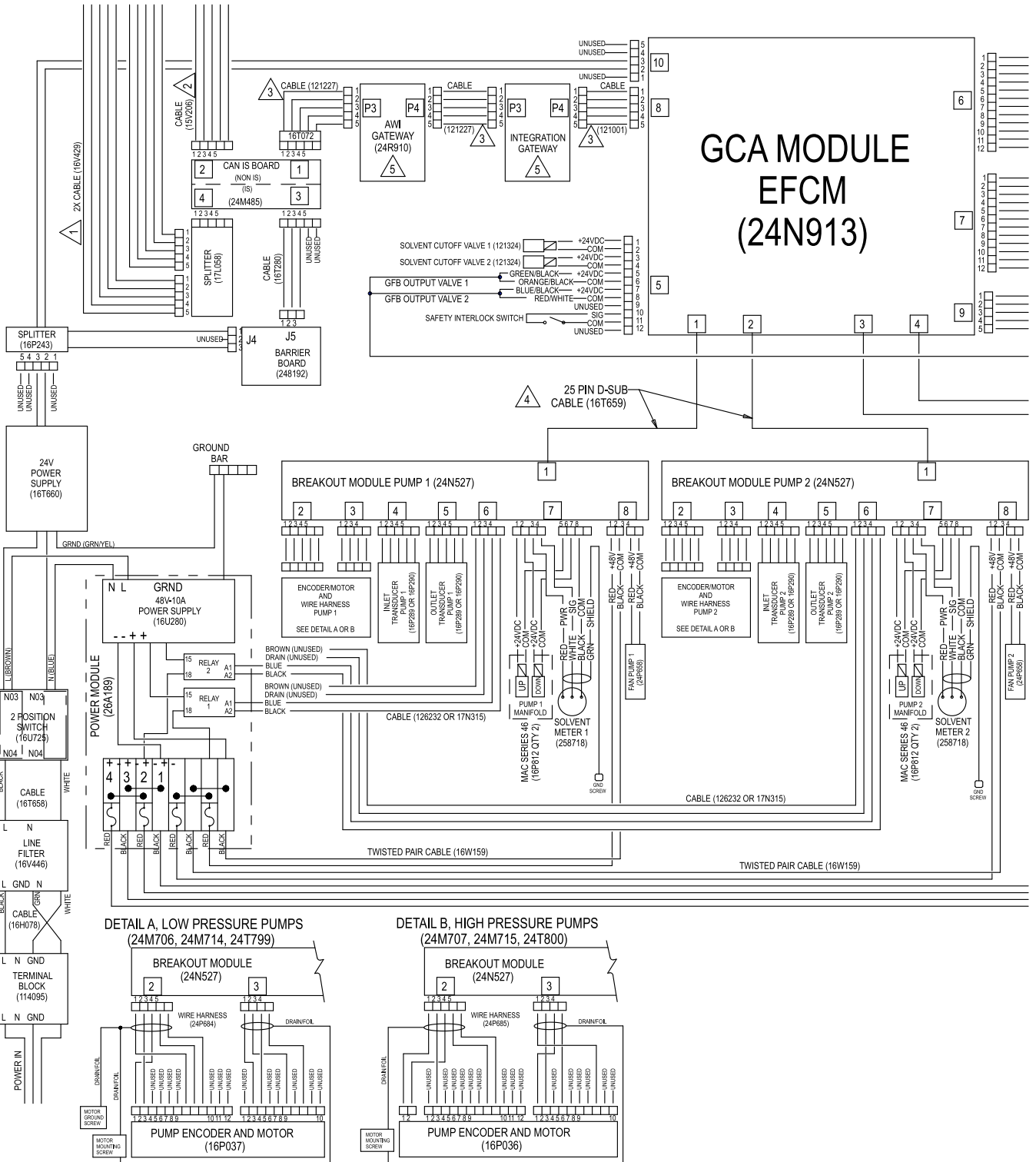

Figure 32 Electrical Schematic, Sheet 2, Part 1
 CONTINUED ON THE NEXT PAGE

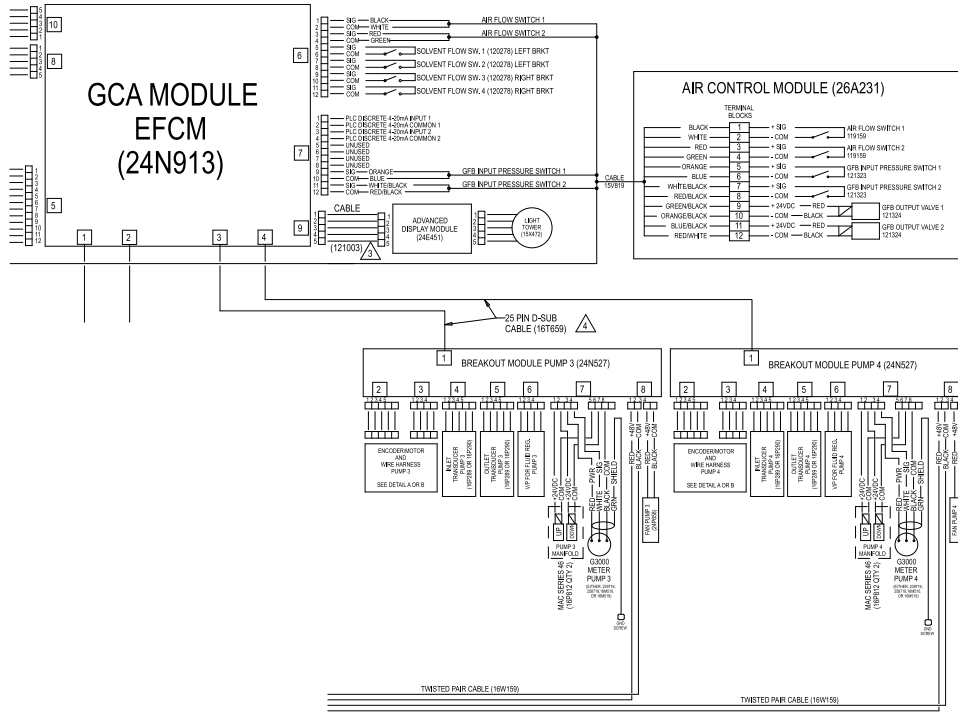

Figure 33 Electrical Schematic, Sheet 2, Part 2

CONTINUED ON THE NEXT PAGE

Electrical Schematics

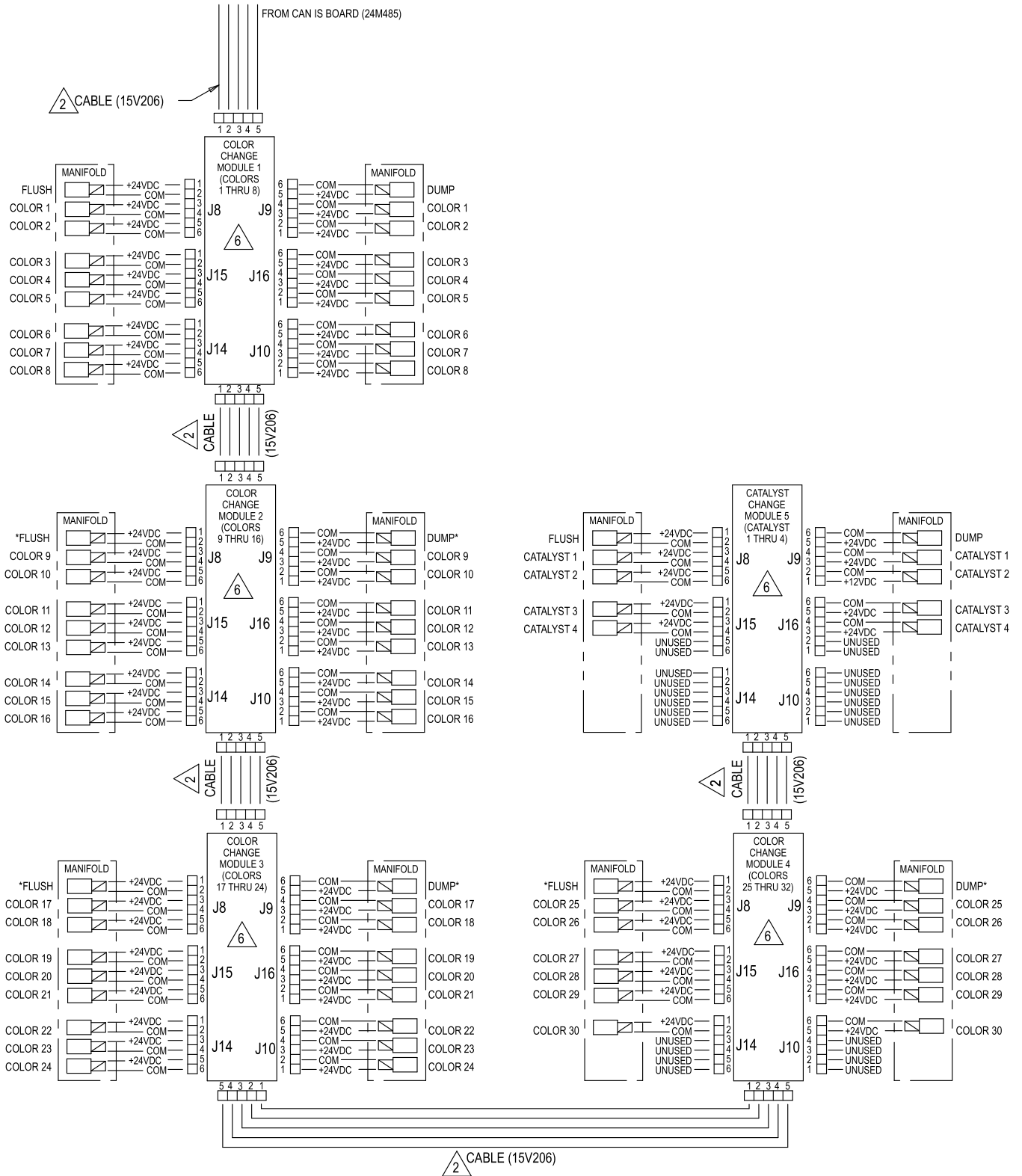

Figure 34 Electrical Schematic, Sheet 3, Part 1

* May be unused in some configurations.

CONTINUED ON THE NEXT PAGE

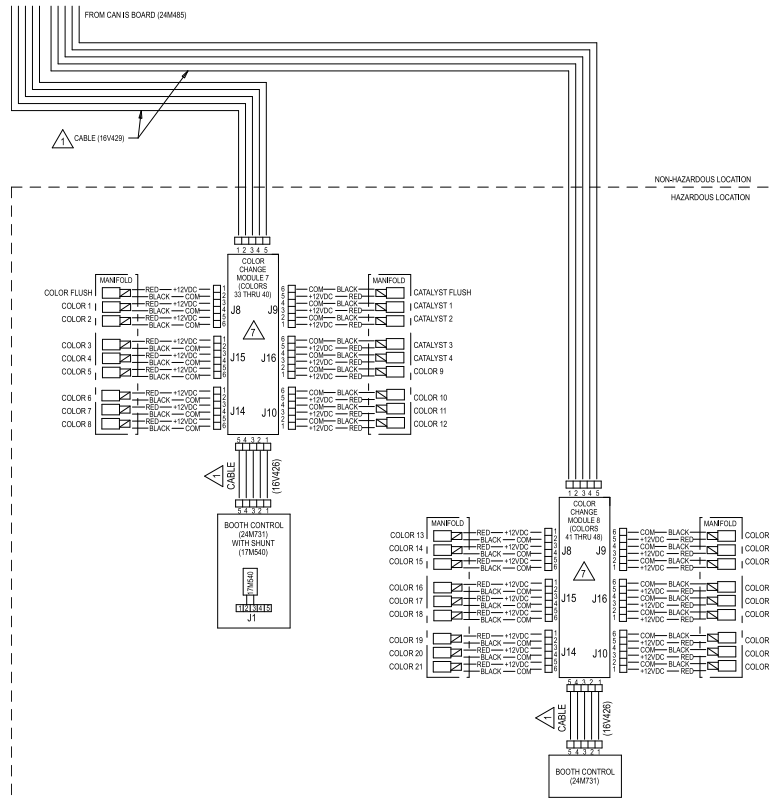
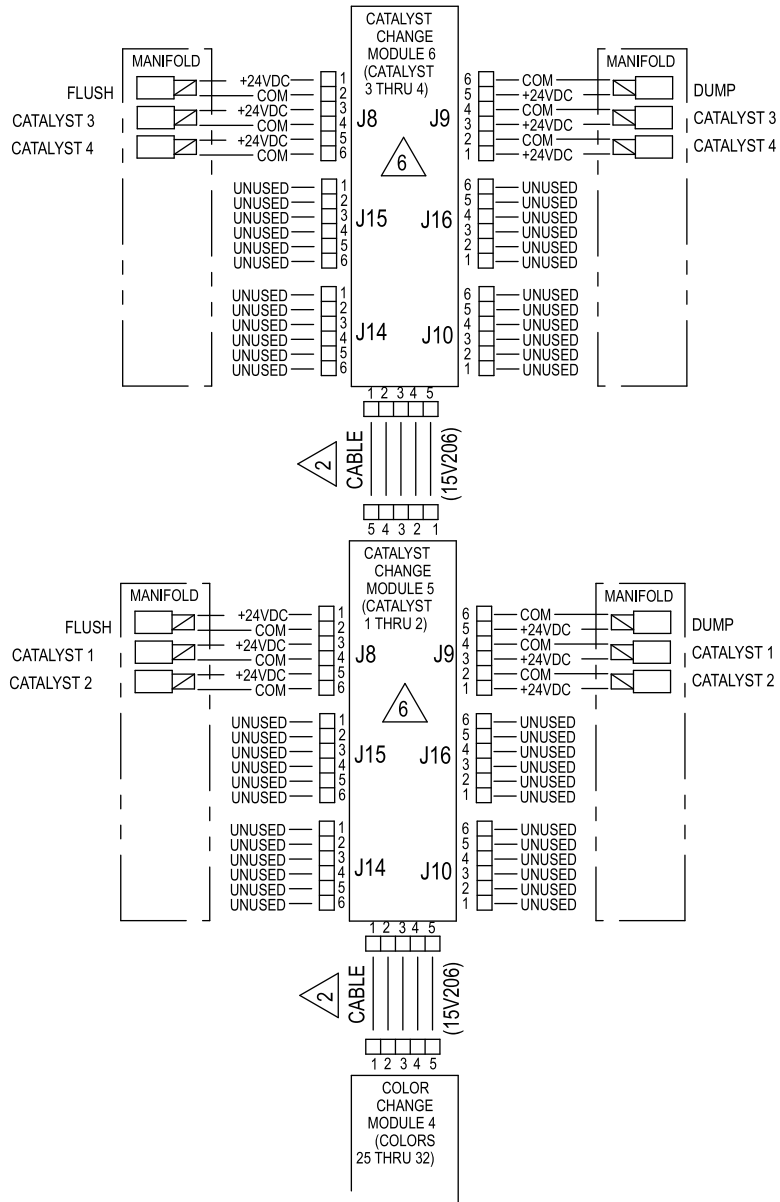

Figure 35 Electrical Schematic, Sheet 3, Part 2
 CONTINUED ON THE NEXT PAGE



ALTERNATE CONFIGURATION
FOR CATALYST CHANGE CONTROL
IN NON-HAZARDOUS LOCATION

Figure 36 Electrical Schematic, Sheet 4, Alternate Configuration for Catalyst Change Control

Optional Cables and Modules

NOTE: The total length of all cable used in the system must not exceed 150 ft (45 m). See the [Electrical Schematics, page 39](#).

1 M12 CAN Cables, for Hazardous Locations	
NOTE: The total length of cable used in the hazardous location must not exceed 120 ft (36 m).	
Cable Part No.	Length ft (m)
16V423	2.0 (0.6)
16V424	3.0 (1.0)
16V425	6.0 (2.0)
16V426	10.0 (3.0)
16V427	15.0 (5.0)
16V428	25.0 (8.0)
16V429	50.0 (16.0)
16V430	100.0 (32.0)
2 M12 CAN Cables, for Non-Hazardous Locations Only	
15U531	2.0 (0.6)
15U532	3.0 (1.0)
15V205	6.0 (2.0)
15V206	10.0 (3.0)
15V207	15.0 (5.0)
15V208	25.0 (8.0)
15U533	50.0 (16.0)
15V213	100.0 (32.0)

3 CAN Cables, for Non-Hazardous Locations Only	
Cable Part No.	Length ft (m)
125306	1.0 (0.3)
123422	1.3 (0.4)
121000	1.6 (0.5)
121227	2.0 (0.6)
121001	3.0 (1.0)
121002	5.0 (1.5)
121003	10.0 (3.0)
120952	13.0 (4.0)

121201	20.0 (6.0)
121004	25.0 (8.0)
121228	50.0 (15.0)

4 25 Pin D-SUB Cables, for Non-Hazardous Locations Only	
16T659	2.5 (0.8)
16V659	6.0 (1.8)

5	See 8. Select Communication Options, page 23 .
----------	--

6 Alternates for Color Change Modules by Part Number (Factory Configuration), for Non-Hazardous Locations Only	
Module Part No.	Description
24T557	2 color/2 catalyst
24T558	4 color/4 catalyst
24T559	6 color/6 catalyst
24T560	8 color/8 catalyst

7 Alternates for Color Change Modules by Part Number (Factory Configuration), for Hazardous Locations Only	
24T571	2 color/2 catalyst
24T572	4 color/2 catalyst
24T573	6 color/2 catalyst
24T574	8 color/2 catalyst, 13–24 color
24T774	12 color/2 catalyst
24T775	4 color/4 catalyst
24T776	6 color/4 catalyst
24T777	8 color/4 catalyst
24T778	12 color/4 catalyst, 13–30 color
24T779	13–18 color

Dimensions

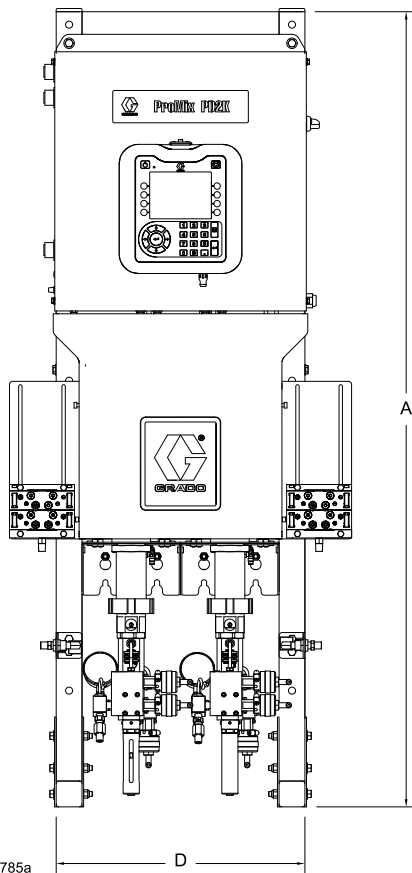

Figure 37

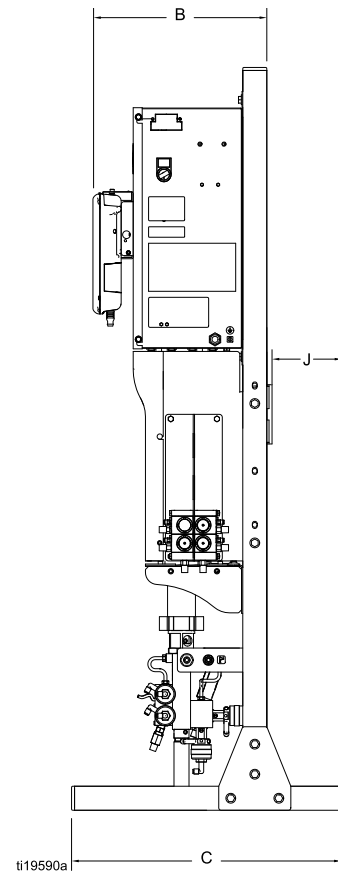

Figure 38

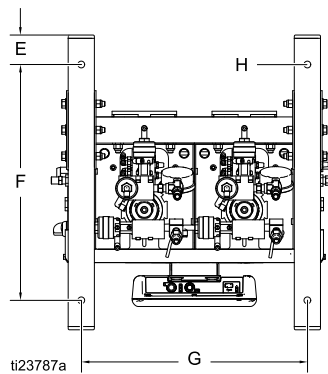

Figure 39

A	B		C	D	E	F	G	H	J
	with ADM	without ADM							
65.3 in. (1659 mm)	14.5 in. (368 mm)	11.12 in. (282 mm)	22.5 in. (572 mm)	19.26 in. (489 mm)	2.25 in. (57 mm)	18.0 in. (457 mm)	17.26 in. (438 mm)	0.52 in. (13 mm)	Minimum 6in (152 mm) from mounting surface

Technical Data

Positive Displacement Proportioner	U.S.	Metric
Maximum fluid working pressure:		
AC1000 and AC1002 Air Spray Systems	300 psi	2.1 MPa, 21 bar
AC2000 and AC2002 Air-Assisted Spray Systems	1500 psi	10.5 MPa, 105 bar
Maximum working air pressure:	100 psi	0.7 MPa, 7.0 bar
Air supply:	85–100 psi	0.6–0.7 MPa, 6.0–7.0 bar)
Air filter inlet size for air logic:	1/4 npt(f)	
Air filter inlet size for atomizing air:	3/8 npt(f)	
Air filtration for air logic:	5 micron (minimum) filtration required; clean and dry air	
Air filtration for atomizing air (user-supplied):	30 micron (minimum) filtration required; clean and dry air	
Mixing ratio range:	0.1:1 to 50:1, ±1%	
Fluids handled:	one or two component: <ul style="list-style-type: none"> • solvent and waterborne paints • polyurethanes • epoxies • acid catalyzed varnishes • moisture sensitive isocyanates 	
Viscosity range of fluid:	20–5000 centipoise	
Fluid filtration (user-supplied):	100 mesh minimum	
Maximum fluid flow:	800 cc/minute (depending on material viscosity)	
Fluid outlet size:	1/4 npt(m)	
External power supply requirements:	90 - 250 Vac, 50/60 Hz, 7 amps maximum draw 15 amp maximum circuit breaker required 8 to 14 AWG power supply wire gauge	
Operating temperature range:	36 to 122°F	2 to 50°C
Storage temperature range:	-4 to 158°F	-20 to 70°C
Weight of base model (approximate):	195 lb	88 kg
Sound data:	Less than 75 dB(A)	
Wetted parts:		
AC1000, AC1002, AC3000, and AC3002	17–4PH, 303, 304 SST, Tungsten carbide (with nickel binder), perfluoroelastomer; PTFE, PPS, UHMWPE	
AC2000, AC2002, AC4000, and AC4002	17–4PH and 316 SST, PEEK, perfluoroelastomer; PTFE, PPS, UHMWPE	

Graco Standard Warranty

Graco warrants all equipment referenced in this document which is manufactured by Graco and bearing its name to be free from defects in material and workmanship on the date of sale to the original purchaser for use. With the exception of any special, extended, or limited warranty published by Graco, Graco will, for a period of twelve months from the date of sale, repair or replace any part of the equipment determined by Graco to be defective. This warranty applies only when the equipment is installed, operated and maintained in accordance with Graco's written recommendations.

This warranty does not cover, and Graco shall not be liable for general wear and tear, or any malfunction, damage or wear caused by faulty installation, misapplication, abrasion, corrosion, inadequate or improper maintenance, negligence, accident, tampering, or substitution of non-Graco component parts. Nor shall Graco be liable for malfunction, damage or wear caused by the incompatibility of Graco equipment with structures, accessories, equipment or materials not supplied by Graco, or the improper design, manufacture, installation, operation or maintenance of structures, accessories, equipment or materials not supplied by Graco.

This warranty is conditioned upon the prepaid return of the equipment claimed to be defective to an authorized Graco distributor for verification of the claimed defect. If the claimed defect is verified, Graco will repair or replace free of charge any defective parts. The equipment will be returned to the original purchaser transportation prepaid. If inspection of the equipment does not disclose any defect in material or workmanship, repairs will be made at a reasonable charge, which charges may include the costs of parts, labor, and transportation.

THIS WARRANTY IS EXCLUSIVE, AND IS IN LIEU OF ANY OTHER WARRANTIES, EXPRESS OR IMPLIED, INCLUDING BUT NOT LIMITED TO WARRANTY OF MERCHANTABILITY OR WARRANTY OF FITNESS FOR A PARTICULAR PURPOSE.

Graco's sole obligation and buyer's sole remedy for any breach of warranty shall be as set forth above. The buyer agrees that no other remedy (including, but not limited to, incidental or consequential damages for lost profits, lost sales, injury to person or property, or any other incidental or consequential loss) shall be available. Any action for breach of warranty must be brought within two (2) years of the date of sale.

GRACO MAKES NO WARRANTY, AND DISCLAIMS ALL IMPLIED WARRANTIES OF MERCHANTABILITY AND FITNESS FOR A PARTICULAR PURPOSE, IN CONNECTION WITH ACCESSORIES, EQUIPMENT, MATERIALS OR COMPONENTS SOLD BUT NOT MANUFACTURED BY GRACO. These items sold, but not manufactured by Graco (such as electric motors, switches, hose, etc.), are subject to the warranty, if any, of their manufacturer. Graco will provide purchaser with reasonable assistance in making any claim for breach of these warranties.

In no event will Graco be liable for indirect, incidental, special or consequential damages resulting from Graco supplying equipment hereunder, or the furnishing, performance, or use of any products or other goods sold hereto, whether due to a breach of contract, breach of warranty, the negligence of Graco, or otherwise.

FOR GRACO CANADA CUSTOMERS

The Parties acknowledge that they have required that the present document, as well as all documents, notices and legal proceedings entered into, given or instituted pursuant hereto or relating directly or indirectly hereto, be drawn up in English. Les parties reconnaissent avoir convenu que la rédaction du présente document sera en Anglais, ainsi que tous documents, avis et procédures judiciaires exécutés, donnés ou intentés, à la suite de ou en rapport, directement ou indirectement, avec les procédures concernées.

Graco Information

For the latest information about Graco products, visit www.graco.com.

For patent information, see www.graco.com/patents.

To place an order, contact your Graco Distributor or call to identify the nearest distributor.

Phone: 612-623-6921 **or Toll Free:** 1-800-328-0211 **Fax:** 612-378-3505

All written and visual data contained in this document reflects the latest product information available at the time of publication. Graco reserves the right to make changes at any time without notice.

Original Instructions. This manual contains English. MM 332458

Graco Headquarters: Minneapolis

International Offices: Belgium, China, Japan, Korea

GRACO INC. AND SUBSIDIARIES • P.O. BOX 1441 • MINNEAPOLIS MN 55440-1441 • USA

Copyright 2014, Graco Inc. All Graco manufacturing locations are registered to ISO 9001.

www.graco.com
Revision H, August 2018