



Grease Jockey® Lubrication Systems Installation and Maintenance Instructions

TRAILER LUBRICATION SYSTEMS

Grease Jockey® trailer lubrication systems can be configured to fit your application needs. Manual single point systems can lubricate a group of points (i.e. the axle or landing gear) from one convenient remote location. Single point systems are easily converted to fully automatic with the addition of an air operated pump.

Automatic systems provide a metered supply of lubricant from the pump into the distribution valves upon a function signal from the trailer parking brake system.

When your trailer fleet is equipped with the Grease Jockey lubrication systems you can have confidence that all the critical points are getting lubricated. Grease Jockey trailer lubrication systems provide a fast, easy to access point of application for lubricating. Critical or hard to reach points are not overlooked.



SYSTEM COMPONENTS

The Grease Jockey Automatic Trailer Lubrication System consists of several parts:

1. E-series Air-Operated Pump
2. One or more MSP Divider Valve assemblies
3. High pressure tubing and hoses
4. Replacement fittings for grease points

PUMP

The pump is an E-series, the selection for most automatic trailer systems. It is a positive displacement, single acting, pneumatically driven pump. The pump mounts to the bottom of a reservoir which has

an integral bracket for mounting the entire assembly to the frame. The pump is actuated when the parking brake is pressurized to release upon moving the vehicle. The "E" pump has a 20:1 air in to lube out ratio, thus output forces can reach approximately 2600 psi. (inlet air = 50 psi min. to 150 psi max.). The duty cycle of the trailers' parking brake usage should be considered in the setting of the adjustable pump output. (See page 6 for a reference chart on output settings of the pump). Grease is applied when the bushings and slack adjusters are at rest.

NOTE: Correct mounting of the pump to the frame is very important. Use the included pump mounting bracket if at all possible. The pump should be mounted so the flat part of the mounting pad is in full contact with the flat of the frame. Failure to mount correctly can result in vibration and fracture of the ears and loss of the pump.

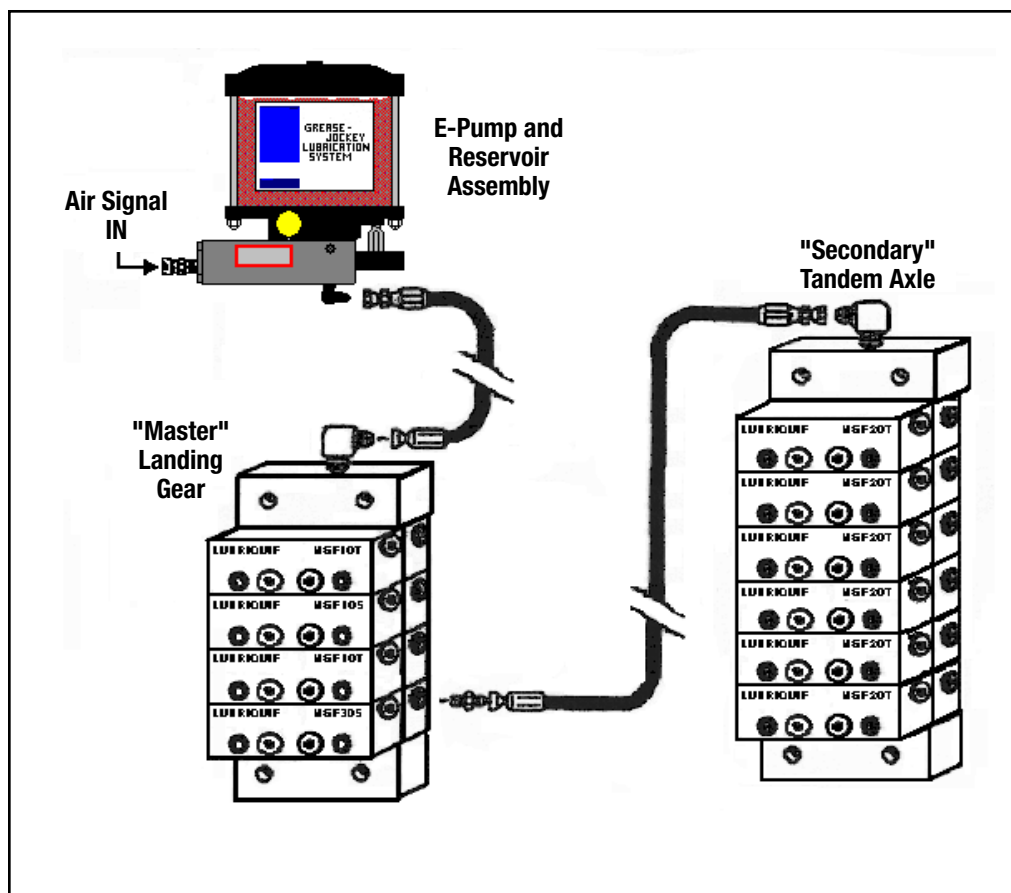

MSP DIVIDER VALVE

The Grease Jockey trailer system uses Graco's "MSP" series progressive divider valve assemblies to meter precise amounts of lubricant to each point. Divider valve assemblies are designed to provide a consistent discharge pattern. The pattern is a result of internal porting and a piston within each valve section. When grease is pumped into the divider valve assembly, each point receives lubricant in turn. When input flow ceases, the valve pistons will stop. When flow resumes it will start again at the point in the cycle where it stopped.

Every piston must complete its stroke before the next piston can move. The pattern in which the pistons move, insures each point is issued its precise amount of grease and no point is overlooked. If any piston fails to complete its designed movement in the series progression, a flow restriction results. This will cause a rise in pressure that indicates a need to check for a blocked lube point, air entrapped inside a divider valve, or contaminants in the lubricant and reservoir. Operation of a six-output divider valve is shown below.

MSP Valve Operation

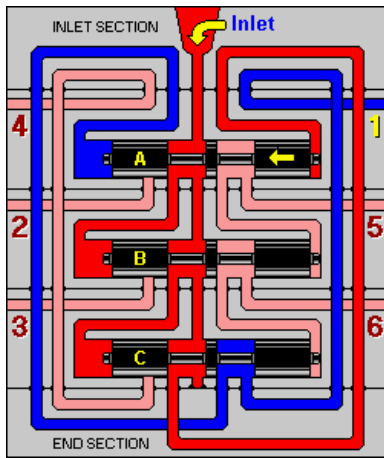

Output #1

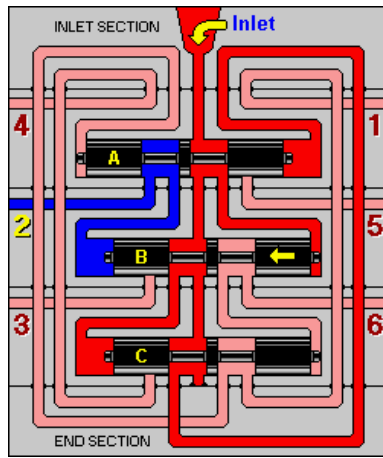

Output #2

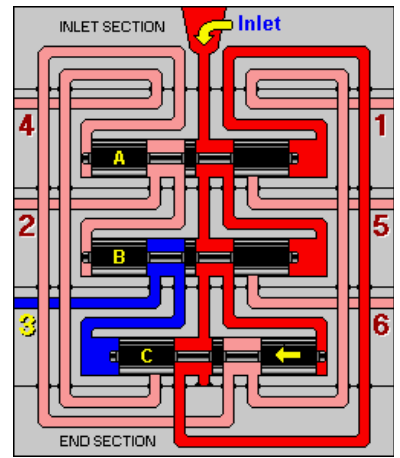

Output #3

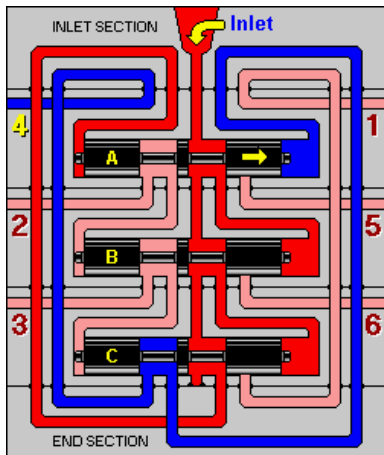

Output #4

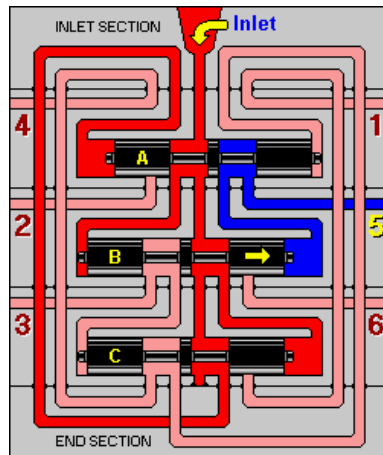

Output #5

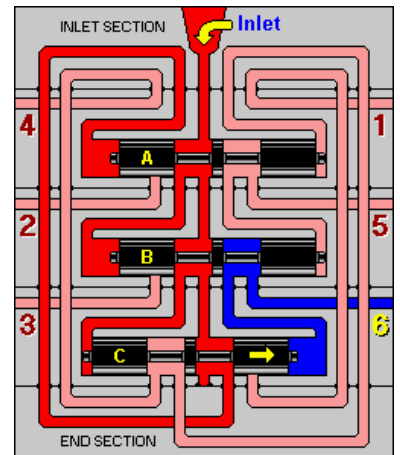

Output #6

WARNING: DO NOT PLUG ANY OUTPUT. This will cause the divider valve to stop working.

PURGING THE SYSTEM

Divider valve assemblies have been individually tested but need to be filled with grease at start up. Air entrapped in a valve assembly can, in certain situations, cause the system to go out of “sync”. This condition could cause a blockage of the series progressive pattern of piston movements. The fault indication would be the same as a blocked distribution point. Pressure will build because flow can not continue through a valve.

Use of a hand operated grease gun is recommended for purging of air and to test the divider valves. Fill the grease gun with clean grease of the same type as is in the system. Connect the grease gun to the inlet port of each divider valve assembly.

Optional cycle indicator 563251 can be used to observe operation of the divider valve: Apply only moderate pressure to each divider valve assembly and observe if there is a build up of pressure and/or if the cycle indicator has movement. The indicator can be located on either side of the first divider valve in the assembly. The balls should move in and out as you pump lubricant into the assembly. Each movement of the balls (in and out) indicates that one cycle of all the valves in the assembly has occurred. This does NOT indicate one complete lubrication cycle. Movement of the balls would indicate the divider valves are operating correctly.

If the indicator balls remain stationary and/or pressure builds at the inlet, loosen one alternate/indicator port at a time and check for flow of lubricant to be free of any air. Begin at the bottom (the end opposite the inlet) and work up the assembly one side at a time. Retighten each port as you proceed. **NOTE:** O-ring plugs need only to be snug, not overly tight.

In the search for a blocked lube point; loosening the alternate/indicator port communicative to the tube point that is blocked would cause the divider valve assembly to start moving again. It’s closure would again stop the system until the blockage downstream of the divider valve has been repaired. Additional air purge information is available in publication 30105.

IMPORTANT: All hose lines must be full of grease and free of any air before connecting them to the divider valve assemblies. Tubing is shipped pre-charged with “00” grease.

HIGH PRESSURE TUBING AND HOSES

IMPORTANT: Always use approved Grease Jockey heavy wall nylon tubing in a lubrication system. Non approved nylon tubing (or air brake hose) should NOT be used. The pressure ratings of other hose and tubing are typically not adequate for lubrication system use. The High Pressure 3/16" OD Lube Point Tubing has the Grease Jockey name imprinted on the individual tubes as well as the sheathing on multi-tube bundles. The 3/16" tubing comes in three configurations: single tubes are black or orange; 2-tube bundles have a black and an orange tube inside a sheath; a 3-tube bundle has a black, blue, and orange tube inside a sheath. The orange tube is typically connected to the highest output. The blue tube is connected to a lesser or equal output. The black tube is connected to the lowest or equal output of the bundle group. The 3/16" distribution tubing from Grease Jockey in standard 10' to 15' lengths comes pre-filled with a quality lithium-based NLGI “00” EP grease. All other hoses or tubing needs to be pre-charged with grease.

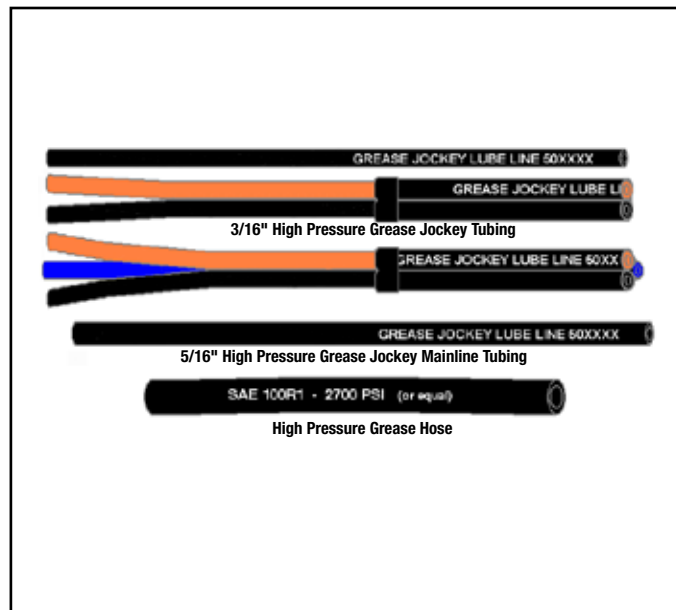
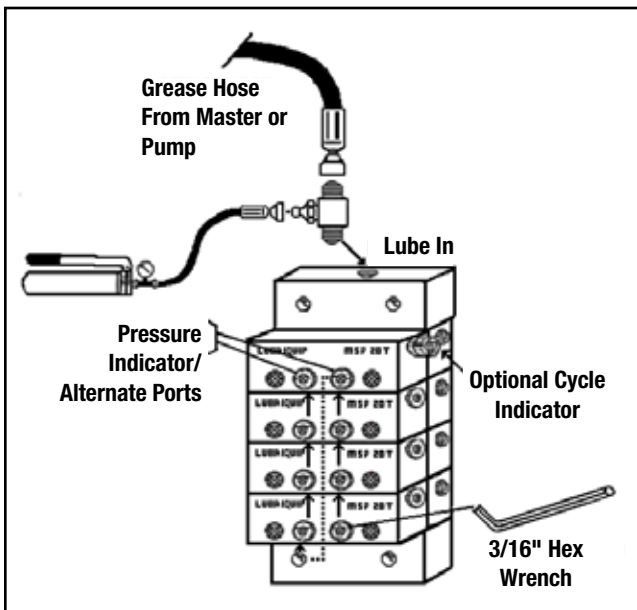

TUBING PREPARATION

1. Measure approximate lengths of tube bundles, leaving extra length for trimming at the lube points.
2. Cut the outside sheath on tube bundles back to the point where this bundle meets it's first lube point. Be careful not to puncture or cut the tubes inside. Use a stripper to help prevent damage to the tubes.
3. Peel back the outside sheath onto itself to create a 1 inch collar and cut off the excess. Be careful not to sever the remaining sheath or tubes.
4. Align tubing with fitting and make cuts square and clean with an anvil razor blade type cutter. **NOTE:** Allow ample slack for tube movement and ease of installation.

A self aligned ferrule is supplied with all 3/16" tube fittings. It is not necessary to remove the nut and ferrule to seat the tube into the fitting.

Care should be taken to make sure the tube is well seated into each fitting. Tighten the nut to hand tight then with a wrench tighten one more turn to seat the ferrule. Nuts can be removed and reassembled up to 8 times by tightening 1/16 turn past hand tight in subsequent assembly.

When installing the tubing and hoses, route the 3/16" distribution tubes where they can be secured with nylon tie straps or tube clamps. Try to run these distribution lines with other hoses or tubing and secure them together. On the axle assembly route all the distribution lines first toward the center area typically where the service brake valve is located. From that point follow each air brake hose down to the brake lube locations. Allow enough tubing when routing over to the slack adjuster and "s" cam points to compensate for axle movement. The lines should never rub against objects around them. Allow ample clearance for vertical movement of the axle. The hose from the pump to the (master) divider valve assembly should be fastened securely to the trailer frame. On trailers with adjustable axle positioning, route the hose along with the existing air lines to the axle carriage. See pictures below.



Pump and Divider Landing Gear Mounting



Frame Mounted Pump and Divider



Tube Routing



S-Cams, Slack Adjuster



S-Cams, Slack Adjusters



Greaseable Clevis Pin

GREASE

Use a semi-fluid grease of NLGI grade “0” or “00” with a lithium base and “EP” additive for standard systems (“E” pumps). Graco part number 557941 (550-400-020) fluid grease is available in a 35# pail from your Grease Jockey component supplier.

Air Purge and Test: All lubrication systems attain optimum operational efficiency when entrapped air has been purged. Air bleeding procedures are necessary, in the event any component is loosened, disconnected or removed from the system (i.e. repairs) as well as at start-up.

The pump should be cycled several times at the full output setting to purge it of air. There is no need to open any screws or plugs on the pump. Observe that the flow of lubricant from the output port (or fitting) is flowing free of any air. To cycle the pump, it may be necessary to apply and release the parking brake if no other method of providing an air signal to the pump is available. (See page 9 for pump adjustments and settings).

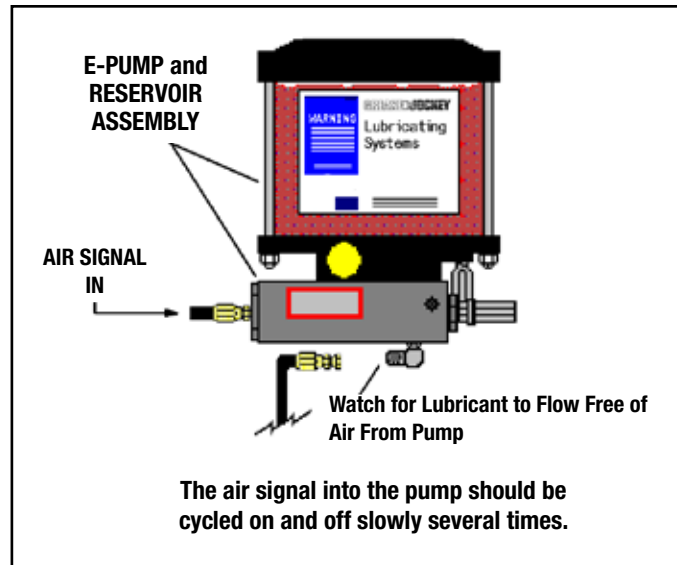

REFERENCE CHART FOR PUMP OUTPUT SETTINGS

Trailer System Configuration	The Number of Park Brake Releases Per Day (Average)				
	4	5	8	10	12
Single Axle Only	Half	1/4	1/8	–	–
Tandem Axle Only	Full	Half	1/4	1/8	–
Single Axle and Landing Gear	–	Full	3/4	Half	1/4
Tandem Axle and Landing Gear	–	–	Full	3/4	Half
Single Axle, Left, and Landing Gear	–	–	–	Full	3/4
Tandem Axle, Left, and Landing Gear	–	–	–	–	Full

PUMP OUTPUT VOLUME SETTINGS

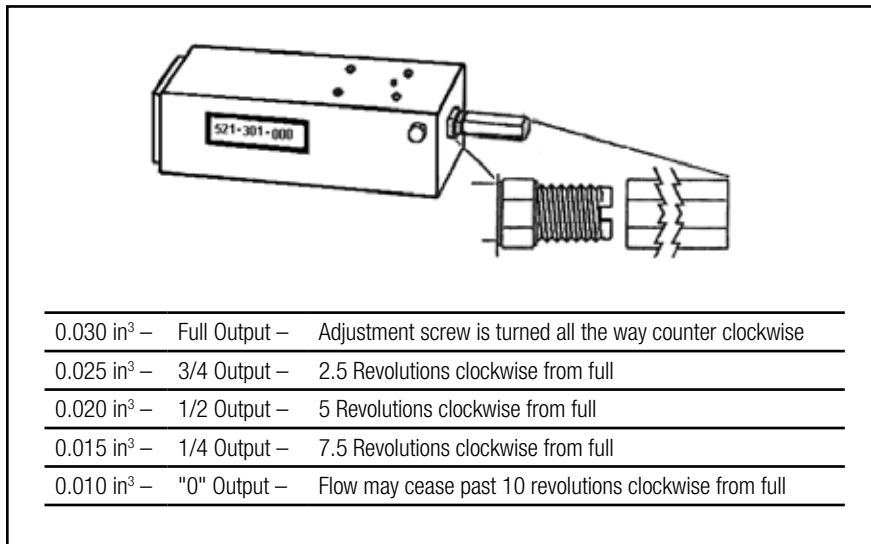

Preventative Maintenance and Troubleshooting

Check the points that are being lubricated.

- If the lubricant volume to all points is adequate, **then** refill reservoir to proper level.
- If the lubricant volume to all points is too high, **then** adjust the pump output volume lower (see above). Refill reservoir to proper level.
- If the lubricant volume to all points is not enough, **then** check the level of grease in the reservoir, then:
 1. If the level is very low = air may have entered the system and an air purge procedure is necessary for all system components (see page 4) check cycle indicator pin for movement (note-on page 4). Refill reservoir to proper level.
 2. If some grease is present = check the system for cycle indicator pin movement (see page 5) you will need to cycle the pump several times as in an air bleed procedure (see page 4). If none, look for a system blockage (see page 3 and 4). Refill reservoir to proper level.
 3. If some grease is present and neither 1 or 2 are the problem = adjust the pump output volume higher (see above for pump adjustment). Refill reservoir to proper level.
- If the lubricant volume to one or more points is not enough, **then** check broken or damaged tubing or hose and repair as needed (purge all air from any repaired or replaced lines before reinstallation). Refill reservoir to proper level.

**TYPICAL AUTOMATIC LUBE SYSTEM FOR A SINGLE AXLE TRAILER
SINGLE AXLE ONLY (6 LUBE POINTS) WITH ADJUSTABLE PUMP**

ORDERING INFORMATION		
Description	Part No.	Old Part No.
E-Pump and Reservoir Assembly	563368	521-301-020
Single Axle MSP Divider Valve	562777	106-200-045
Grease Hose	556769	443-700-023
1/8 Elbow	556638	435-440-030
1/8 Connector	556644	435-460-030
1/4 SAE Elbow	15K740	550-400-800
1/4 SAE Connector	562992	435-702-367

Point No.	Description	MSP No.	Color	Tubing	Fitting
1	"S" Cam Inboard	20T	Orange	3-Tube	1/8 Elbow
2	Slack Adjuster	20T	Black	3-Tube	1/8 Elbow
3	"S" Cam Outboard	20T	Blue	3-Tube	1/8 Conn
4	"S" Cam Inboard	20T	Orange	3-Tube	1/8 Elbow
5	Slack Adjuster	20T	Black	3-Tube	1/8 Elbow
6	"S" Cam Outboard	20T	Blue	3-Tube	1/8 Conn

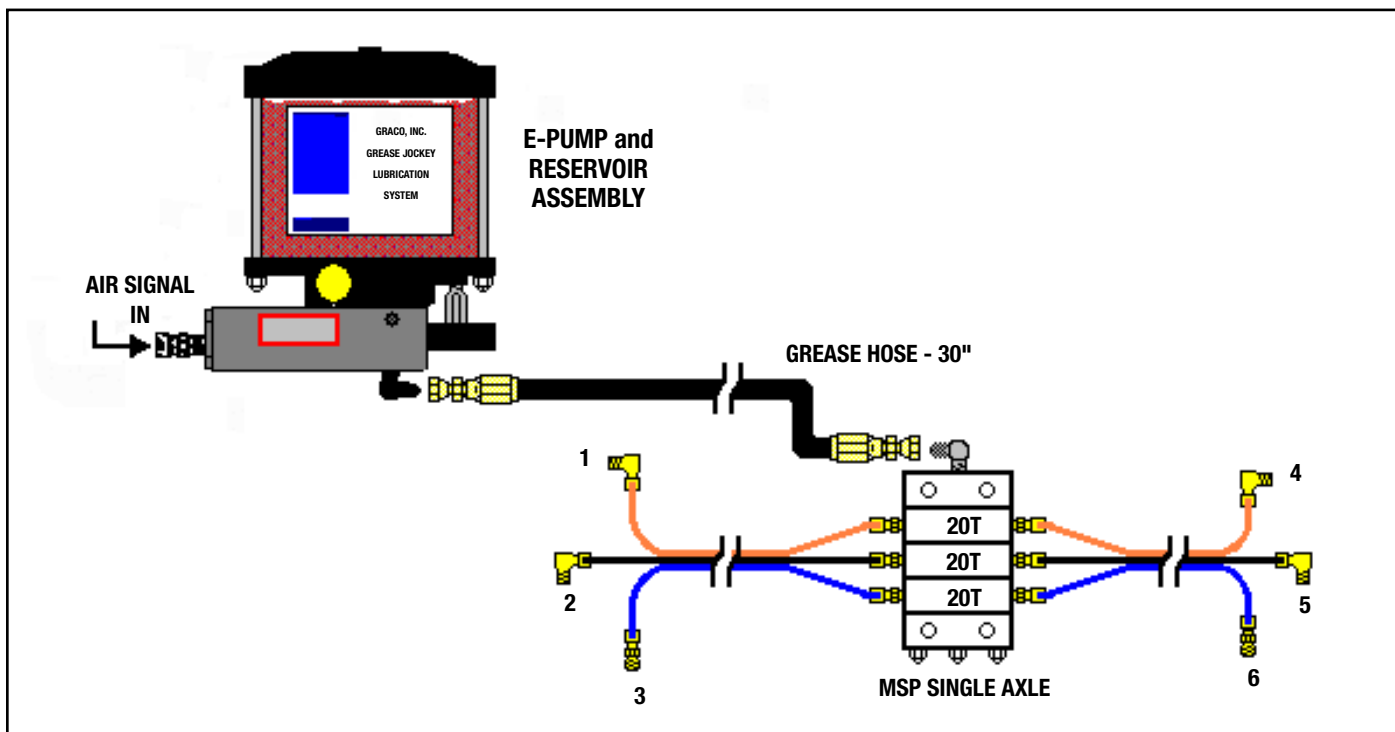

**TYPICAL AUTOMATIC LUBE SYSTEM FOR A TANDEM AXLE TRAILER
TANDEM AXLE ONLY (12 LUBE POINTS) WITH ADJUSTABLE PUMP**

ORDERING INFORMATION		
Description	Part No.	Old Part No.
E-Pump and Reservoir Assembly	563368	521-301-020
Tandem Axle MSP Divider Valve	562776	106-200-043
Grease Hose	556769	443-700-023
1/8 Elbow	556638	435-440-030
1/8 Connector	556644	435-460-030
1/4 SAE Elbow	15K740	550-400-800
1/4 SAE Connector	562992	435-702-367

Point No.	Description	MSP No.	Color	Tubing	Fitting
1	"S" Cam Inboard	20T	Orange	3-Tube	1/8 Elbow
2	Slack Adjuster	20T	Black	3-Tube	1/8 Elbow
3	"S" Cam Outboard	20T	Blue	3-Tube	1/8 Conn
4	"S" Cam Inboard	20T	Orange	3-Tube	1/8 Elbow
5	Slack Adjuster	20T	Black	3-Tube	1/8 Elbow
6	"S" Cam Outboard	20T	Blue	3-Tube	1/8 Conn
7	"S" Cam Inboard	20T	Orange	3-Tube	1/8 Elbow
8	Slack Adjuster	20T	Black	3-Tube	1/8 Elbow
9	"S" Cam Outboard	20T	Blue	3-Tube	1/8 Conn
10	"S" Cam Inboard	20T	Orange	3-Tube	1/8 Elbow
11	Slack Adjuster	20T	Black	3-Tube	1/8 Elbow
12	"S" Cam Outboard	20T	Blue	3-Tube	1/8 Conn

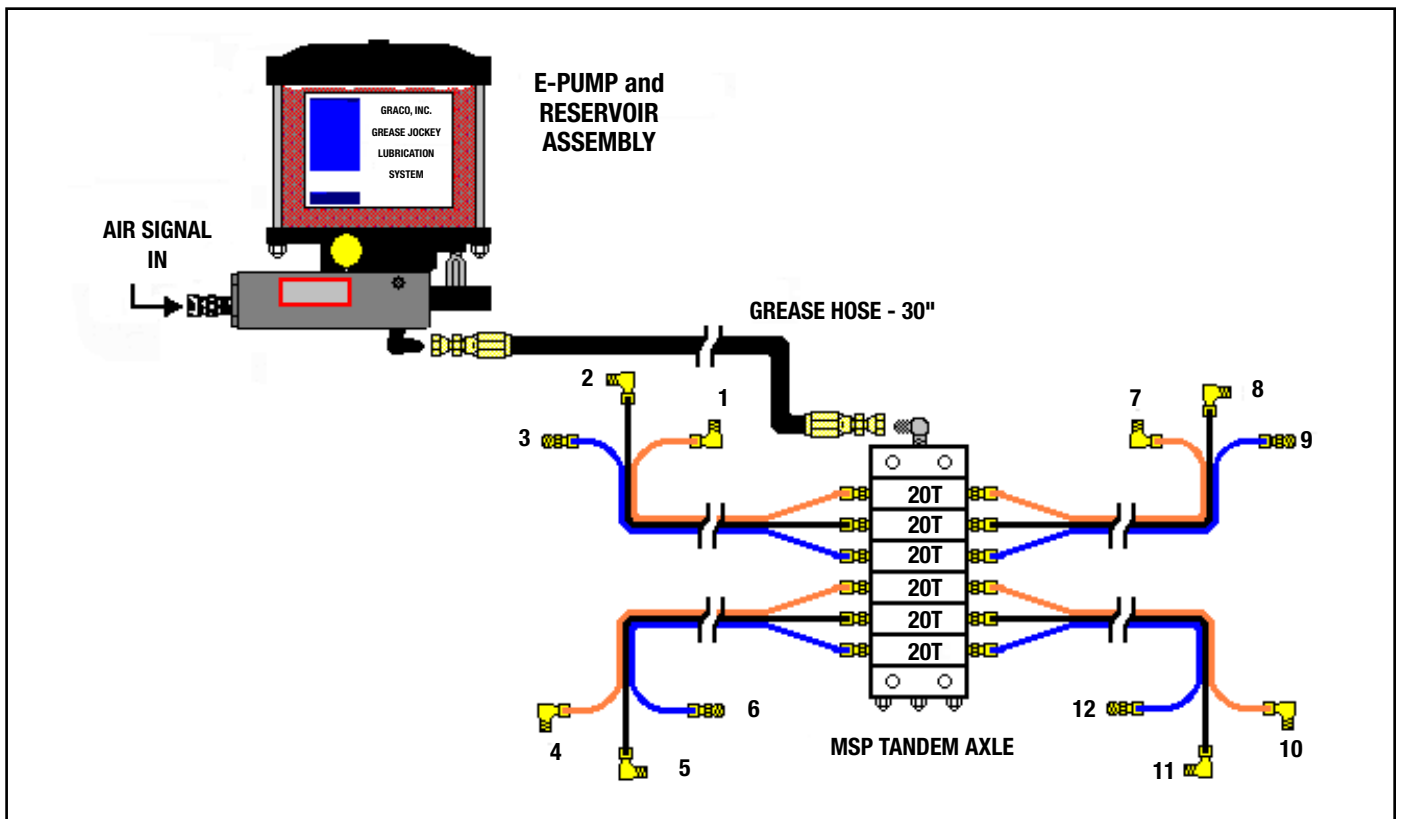

TYPICAL AUTOMATIC LUBE SYSTEM FOR A SINGLE AXLE TRAILER AND LANDING GEAR (11 LUBE POINTS) WITH ADJUSTABLE PUMP

ORDERING INFORMATION		
Description	Part No.	Old Part No.
E-Pump and Reservoir Assembly	563368	521-301-020
MSP Master and Landing Gear	562779	106-200-048
MSP Single Axle	562777	106-200-045
Grease Hose	556769	443-700-023
1/8 Elbow	556638	435-440-030
1/8 Connector	556644	435-460-030
1/4 SAE Elbow	15K740	550-400-800
1/4 SAE Connector	562992	435-702-367

LANDING GEAR MSP DIVIDER VALVE MSP 4 (MASTER)					
Point No.	Description	MSP No.	Color	Tubing	Fitting
1	Leg	10T	Black	3-Tube 10ft	1/4 SAE Elbow
2	Gear Box	10S	Blue	3-Tube 10ft	1/4 SAE Elbow
3	Leg	10T	Orange	3-Tube 10ft	1/4 SAE Conn
4	Outlet To Single Axle	30S	—	Grease Hose	—
5	Leg	10T	Black	2-Tube 10ft	1/4 SAE Elbow
6	Plugged	—	—	2-Tube 10ft	—
7	Leg	10S	Orange	2-Tube 10ft	1/4 SAE Conn
8	Plugged	—	—	—	—

SINGLE AXLE MSP DIVIDER VALVE MSP 3					
Point No.	Description	MSP No.	Color	Tubing	Fitting
1	"S" Cam Inboard	20	Orange	3-Tube 12ft	1/8 Elbow
2	Slack Adjuster	20	Black	3-Tube 12ft	1/8 Elbow
3	"S" Cam Outboard	20	Blue	3-Tube 12ft	1/8 Conn
4	"S" Cam Inboard	20	Orange	3-Tube 10ft	1/8 Elbow
5	Slack Adjuster	20	Black	3-Tube 10ft	1/8 Elbow
6	"S" Cam Outboard	20	Blue	3-Tube 10ft	1/8 Conn

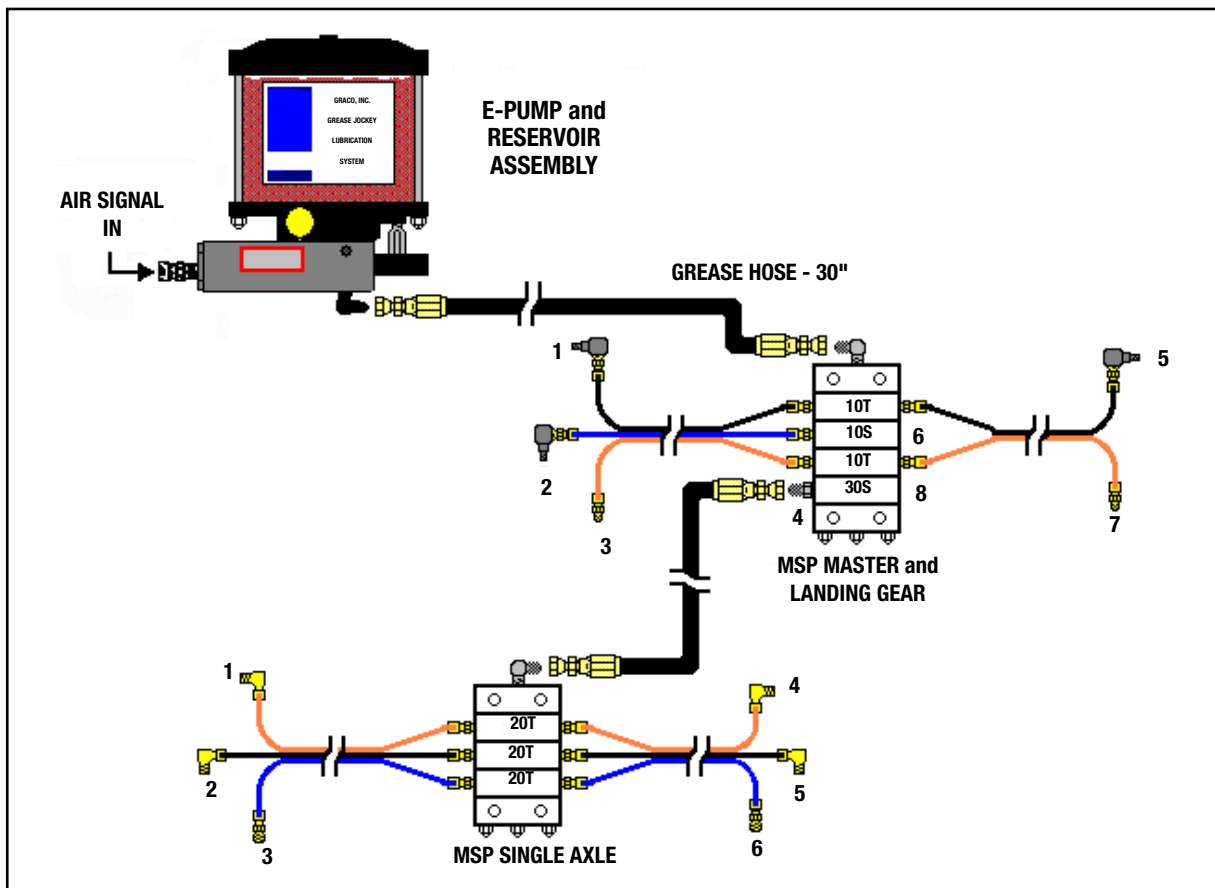

TYPICAL AUTOMATIC LUBE SYSTEM FOR A TANDEM AXLE TRAILER AND LANDING GEAR (17 LUBE POINTS) WITH ADJUSTABLE PUMP

LANDING GEAR MSP DIVIDER VALVE MSP 4 (MASTER)					
Point No.	Description	MSP No.	Color	Tubing	Fitting
1	Leg	10T	Black	3-Tube 10 ft	1/4 SAE Elbow
2	Gear Box	10S	Blue	3-Tube 10 ft	1/4 SAE Elbow
3	Leg	10T	Orange	3-Tube 10 ft	1/4 SAE Conn
4	Outlet to Tandem Axle	30S	—	Grease Hose	—
5	Leg	10T	Black	2-Tube 10 ft	1/4 SAE Elbow
6	Plugged	—	—	2-Tube 10 ft	—
7	Leg	10S	Orange	2-Tube 10 ft	1/4 SEA Conn
8	Plugged	—	—	—	—

TANDEM AXLE MSP DIVIDER VALVE MSP 6					
Point No.	Description	MSP No.	Color	Tubing	Fitting
1	"S" Cam Inboard	20	Orange	3-Tube 12 ft	1/8 Elbow
2	Slack Adjuster	20	Black	3-Tube 12 ft	1/8 Elbow

3	"S" Cam Outboard	20	Blue	3-Tube, 12 ft	1/8 Conn
4	"S" Cam Inboard	20	Orange	3-Tube, 10 ft	1/8 Elbow
5	Slack Adjuster	20	Black	3-Tube, 10 ft	1/8 Elbow
6	"S" Cam Outboard	20	Blue	3-Tube, 10 ft	1/8 Conn
7	"S" Cam Inboard	20	Orange	3-Tube, 12 ft	1/8 Elbow
8	Slack Adjuster	20	Black	3-Tube, 12 ft	1/8 Elbow
9	"S" Cam Outboard	20	Blue	3-Tube, 12 ft	1/8 Conn
10	"S" Cam Inboard	20	Orange	3-Tube, 10 ft	1/8 Elbow
11	Slack Adjuster	20	Black	3-Tube, 10 ft	1/8 Elbow
12	"S" Cam Outboard	20	Blue	3-Tube, 10 ft	1/8 Conn

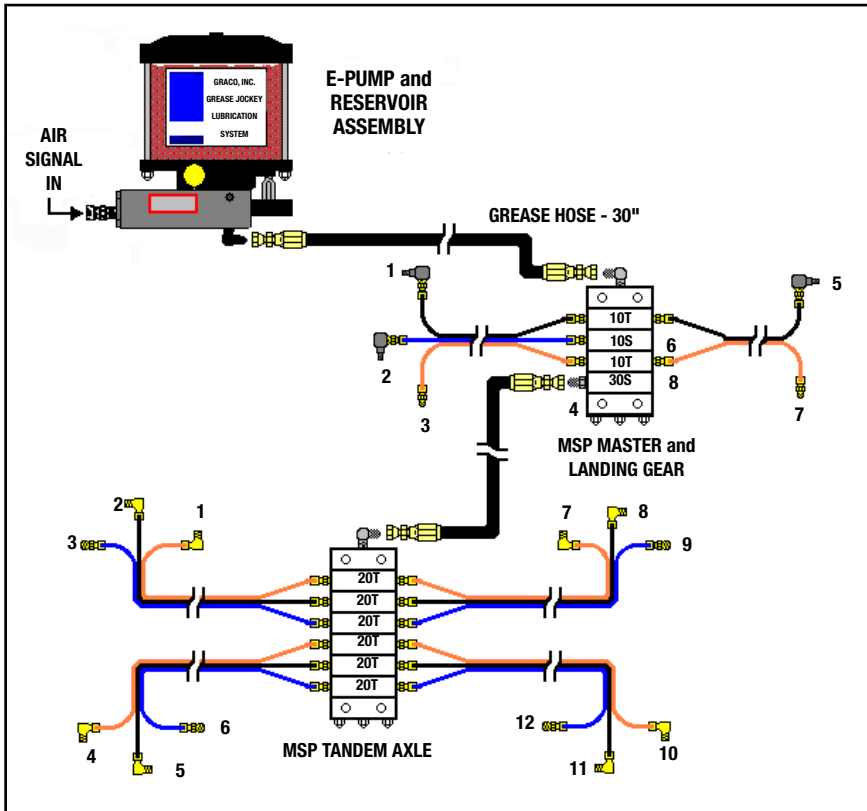

ORDERING INFORMATION		
Description	Part No.	Old Part No.
E-Pump and Reservoir Assembly	563368	521-301-020
MSP Master and Landing Gear	562779	106-200-048
MSP Tandem Axle	562776	106-200-043
Grease Hose	556769	443-700-023
1/8 Elbow	556638	435-440-030
1/8 Connector	556644	435-460-030
1/4 SAE Elbow	15K740	550-400-800
1/4 SAE Connector	562992	435-702-367

REPLACEMENT PARTS ORDERING INFORMATION

Description	Part No.	Old Part No.
4 lb Reservoir and Adjustable E-Pump Assy.	563368	521-301-020
Reservoir Repair Kit	563725	550-306-504
Adjustable E-Pump Assembly	563367	521-301-000
Pump Repair Kit	563945	560-002-973
Reservoir Fill Stud, Male	557880	550-050-300
Fill Stud Coupling, Female	121474	550-050-230
Dust Cap for Fill Stud	557875	550-050-130
Single Tube 3/16 in O.D. Nylon Heavy Wall, 15 ft	563786	550-450-210
Two Tube Bundle 3/16 in O.D. Nylon Heavy Wall, 15 ft	563788	550-450-720
Three Tube Bundle 3/16 in O.D. Nylon Heavy Wall, 15 ft	563783	550-450-100
Plastic Cable Ties, 100 pcs	563770	550-402-340
Tube, Hose Clamps, 5/16 in	557943	550-400-040
Tube, Hose Clamps, 3/8 in	557946	550-400-070
Tube, Hose Clamps, 7/16 in	557944	550-400-050
Tube, Hose Clamps, 1/2 in	557947	550-400-080
Tube, Hose Clamps, 5/8 in	557945	550-400-060
1/4 in Hose SAE 100R7 Construction (or equal), 100 ft	128572	–
Hose End for 1/4 in Size #4 JIC Swivel	128563	–
Outlet Hose Fitting from Divider Valve Assembly 1/4 in NPT x #4 JIC	556762	441-070-030
Inlet Hose Fitting from Divider Valve Assembly 1/4 in NPT x #4 JIC	556764	441-080-030

REPLACEMENT PARTS ORDERING INFORMATION

Description	Part No.	Old Part No.
Cycle Indicator, Ball Type, for use w/MSP Divider Valve 7/16-20 Thread	563251	509-932-522
Connector, 1/8 in NPT Male to 3/16 in O.D. Tube	556644	435-460-030
Elbow, 1/8 in NPT Male to 3/16 in O.D. Tube	556638	435-440-030
Straight Conn 1/4-28 x 3/16 O.D. Tube	562995	435-702-367
Union, 3/16 in Tube to 3/16 in Tube	556647	435-470-020
Zerk Adaptor, Snap on, 90° Elbow	563776	550-402-860
Nut w/Captured Ferrule	556660	435-702-340
Elbow, 1/8 in NPT Male to 1/8 in NPT Female, 45°	557395	509-111-000
Elbow, 1/8 in NPT Male to 1/8 in NPT Female to 1/8-27 PTF-SAE short male, 90°	15K783	509-110-000
Elbow, 1/4-28 SAE Male to 1/8 in NPT Female, 45°	557954	550-400-870
Elbow, 1/4-28 SAE Male to 1/8 in NPT Female, 90°	15K740	550-400-800
Adaptor, 1/8 NPT to 1/8 NPT	557392	509-027-000
Adaptor, 1/4-28 SAE to 1/4-28 SAE	557955	550-400-880
Street Tee	556420	412-380-020
Zerk Fitting, Straight	555888	51379
Bushing, 1/4 in NPT x 1/8 in NPT	556402	412-170-010

Contact us today!

To receive product information or talk with a Graco representative, call 800-533-9655 or visit us online at www.graco.com.

