

Endura-Flo™ 3D150, 3D350, 4D150, and 4D350 Diaphragm Pump

333015J
EN

Used to pump waterborne and solvent-based paints and catalysts. For professional use only.



Important Safety Instructions

Read all warnings and instructions in this manual. **Save these instructions.**

*See page 2 for model information, including maximum pressures and approvals.
3D150 and 4D350 models shown on cover.*

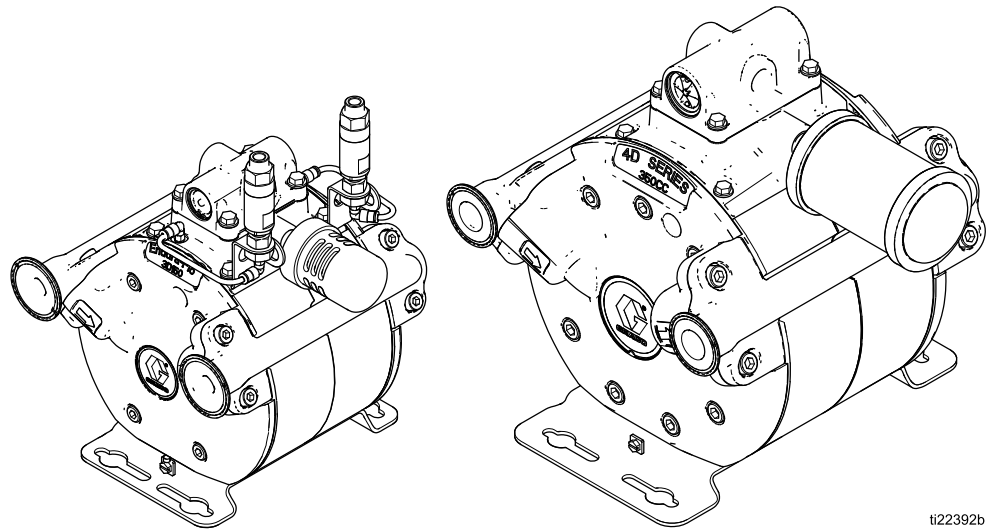

ti22392b

Contents

Related Manuals	2	Preventive Maintenance Schedule	13
Models	2	Troubleshooting	14
Warnings	4	Repair/Service	16
Installation	6	Repair or Replace the Air Valve	16
General Information	6	DataTrak	19
Instructions Before First Use	6	Disassemble the Fluid Section	20
Mount the Pump	6	Disassemble the Center Section	22
Air Line	7	Reassemble the Center Section	23
Fluid Suction Line	7	Reassemble the Fluid Section	25
Fluid Outlet Line	7	Torque Instructions	27
Remote Exhaust	8	Parts	28
Breather Valve Mounting Requirements for 3D150 and 3D350 Models	8	Air Valve Parts	31
Breather Valves	8	Repair Kits	33
Grounding	11	Conversion Kits	34
Operation	12	Alternative Check Valve Kit	34
Start and Adjust the Pump	12	Accessories	34
Pressure Relief Procedure	12	Performance Charts	35
Pump Shutdown	12	Mounting Dimensions	39
Maintenance	13	Technical Specifications	41
Lubrication	13	Notes	43
Flushing and Storage	13		
Tighten Threaded Connections	13		

Related Manuals

Manual Number	Title
313840	DataTrak Kit Instructions
3A5589	3D150 and 3D350 Conversion Kits 25D984 and 25D985 for Endura-Flo™ Diaphragm Pumps

Models

Models have the following maximum pressures. See [Performance Charts, page 35](#), for actual working pressures and flow rates.

Model	Maximum Fluid Working Pressure	Maximum Static Fluid Pressure	Maximum Air Input Pressure
3D150	300 psi (2.1 MPa, 21 bar)	330 psi (2.3 MPa, 23 bar)	100 psi (0.7 MPa, 7 bar)
3D350	300 psi (2.1 MPa, 21 bar)	330 psi (2.3 MPa, 23 bar)	
4D150	400 psi (2.8 MPa, 28 bar)	430 psi (3.0 MPa, 30 bar)	
4D350	400 psi (2.8 MPa, 28 bar)	430 psi (3.0 MPa, 30 bar)	

Models have the following porting and air valves.

Model		Size	Porting	Air Valve	
3D150	Pump, 3:1 AODD	25M739	150 cc	Tri-clamp	Standard
		25M740	150 cc	npt	
		25M741	150 cc	bspp	
		25M742	150 cc	Tri-clamp	Advanced (with DataTrak monitoring and runaway protection)*
		25M743	150 cc	npt	
		25M744	150 cc	bspp	
3D350	Pump, 3:1 AODD	25M757	350 cc	Tri-clamp	Standard
		25M758	350 cc	npt	
		25M759	350 cc	bspp	
		25M760	350 cc	Tri-clamp	Advanced (with DataTrak monitoring and runaway protection)*
		25M761	350 cc	npt	
		25M762	350 cc	bspp	
4D150	Pump, 4:1 AODD	24W345	150 cc	Tri-clamp	Standard
		24W346	150 cc	npt	
		24W347	150 cc	bspp	
		24W348	150 cc	Tri-clamp	Advanced (with DataTrak monitoring and runaway protection)*
		24W349	150 cc	npt	
		24W350	150 cc	bspp	
4D350	Pump, 4:1 AODD	24W351	350 cc	Tri-clamp	Standard
		24W352	350 cc	npt	
		24W353	350 cc	bspp	
		24W354	350 cc	Tri-clamp	Advanced (with DataTrak monitoring and runaway protection)*
		24W355	350 cc	npt	
		24W356	350 cc	bspp	

Standard pump models are certified:



Advanced pump models are certified:









* DataTrak is certified:



Warnings

The following warnings are for the setup, use, grounding, maintenance, and repair of this equipment. The exclamation point symbol alerts you to a general warning and the hazard symbols refer to procedure-specific risks. When these symbols appear in the body of this manual or on warning labels, refer back to these warnings. Product-specific hazard symbols and warnings not covered in this section may appear throughout the body of this manual where applicable.

 <h2 style="margin: 0;">WARNING</h2>	
   	<p>FIRE AND EXPLOSION HAZARD</p> <p>Flammable fumes, such as solvent and paint fumes, in the work area can ignite or explode. Paint or solvent flowing through the equipment can cause static sparking. To help prevent fire and explosion:</p> <ul style="list-style-type: none"> • Use equipment only in a well-ventilated area. • Eliminate all ignition sources; such as pilot lights, cigarettes, portable electric lamps, and plastic drop cloths (potential static arc). • Ground all equipment in the work area. See Grounding instructions. • Never spray or flush solvent at high pressure. • Keep the work area free of debris, including solvent, rags, and gasoline. • Do not plug or unplug power cords, or turn power or light switches on or off when flammable fumes are present. • Use only grounded hoses. • Hold the gun firmly to the side of a grounded pail when triggering into a pail. Do not use pail liners unless they are antistatic or conductive. • Stop operation immediately if static sparking occurs or you feel a shock. Do not use equipment until you identify and correct the problem. • Keep a working fire extinguisher in the work area.
  	<p>PRESSURIZED EQUIPMENT HAZARD</p> <p>Fluid from the equipment, leaks, or ruptured components can splash in the eyes or on skin and cause serious injury.</p> <ul style="list-style-type: none"> • Follow the Pressure Relief Procedure when you stop spraying/dispensing and before cleaning, checking, or servicing equipment. • Tighten all fluid connections before operating the equipment. • Check hoses, tubes, and couplings daily. Replace worn or damaged parts immediately.



WARNING



EQUIPMENT MISUSE HAZARD

Misuse can cause death or serious injury.

- Do not operate the unit when fatigued or under the influence of drugs or alcohol.
- Do not exceed the maximum working pressure or temperature rating of the lowest rated system component. See **Technical Specifications** in all equipment manuals.
- Use fluids and solvents that are compatible with equipment wetted parts. See **Technical Specifications** in all equipment manuals. Read fluid and solvent manufacturer's warnings. For complete information about your material, request a Safety Data Sheet (SDS) from your distributor or retailer.
- Turn off all equipment and follow the **Pressure Relief Procedure** when equipment is not in use.
- Check equipment daily. Repair or replace worn or damaged parts immediately with genuine manufacturer's replacement parts only.
- Do not alter or modify equipment. Alterations or modifications may void agency approvals and create safety hazards.
- Make sure all equipment is rated and approved for the environment in which you are using it.
- Use equipment only for its intended purpose. Call your distributor for information.
- Route hoses and cables away from traffic areas, sharp edges, moving parts, and hot surfaces.
- Do not kink or over bend hoses or use hoses to pull equipment.
- Keep children and animals away from the work area.
- Comply with all applicable safety regulations.



TOXIC FLUID OR FUMES HAZARD

Toxic fluids or fumes can cause serious injury or death if splashed in the eyes or on skin, inhaled, or swallowed.

- Read the Safety Data Sheet (SDS) to know the specific hazards of the fluids you are using.
- Route exhaust away from work area. If the diaphragm ruptures, fluid may be exhausted into the air.
- Store hazardous fluid in approved containers, and dispose of it according to applicable guidelines.



PERSONAL PROTECTIVE EQUIPMENT

Wear appropriate protective equipment when in the work area to help prevent serious injury, including eye injury, hearing loss, inhalation of toxic fumes, and burns. Protective equipment includes but is not limited to:

- Protective eyewear and hearing protection.
- Respirators, protective clothing, and gloves as recommended by the fluid and solvent manufacturer.



Installation

General Information

- The [Typical Installation](#) is only a guide for installing system components and accessories. It is not an actual system design. Contact your Graco distributor for assistance in designing a system to suit your particular needs.
- Always use Genuine Graco Parts and Accessories, available from your Graco distributor. If you supply your own accessories, be sure they are adequately sized and pressure-rated for your system.
- Reference numbers and letters in parentheses refer to the reference numbers in the figures and in the Parts Lists.

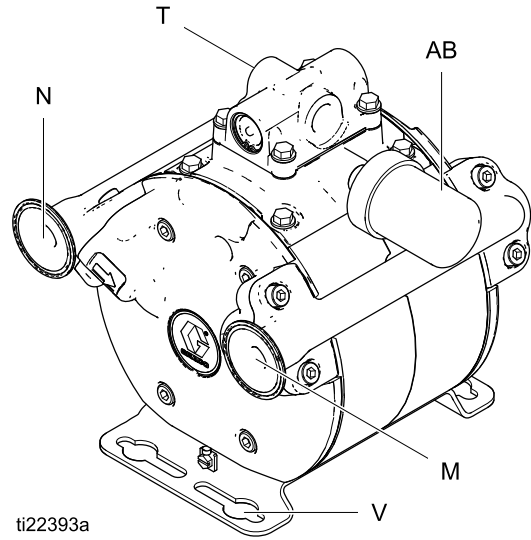

Instructions Before First Use

Before using the pump:

1. Check that all fluid cover and fluid manifold fasteners are tight. Follow the [Torque Instructions, page 27](#).
2. Install the muffler (AB).

Mount the Pump

1. For ease of operation and service, mount the pump so the air inlet (T), fluid inlet (N), and fluid outlet (M) ports are easily accessible.

NOTE: The arrow labels on the pump show fluid inlet and outlet directions.

2. Mount the pump in a well-ventilated area with sufficient clearance on all sides for operator access and servicing.
3. The air inlet (T) must be on the opposite side of the pump from the muffler (AB).
4. The pump can be mounted in any orientation. The fluid manifolds can be rotated to face either direction.

NOTE: Stand Kit 17H315 is available as a mounting option. For more information, see [Accessories, page 34](#).



5. Be sure the mounting can support the weight of the pump, hoses, and accessories as well as the stress caused during operation. The pump has four mounting holes (V) for M10 (3/8 in.) bolts. See [Mounting Dimensions, page 39](#).

Triton Users Note: The mounting hole pattern is the same.

KEY		
M	Fluid Outlet	3D150 and 4D150: 1 in. tri-clamp flange, 1/2 in. npt, or 1/2 in. bspp
		3D350 and 4D350: 1 in. tri-clamp flange, 3/4 in. npt, or 3/4 in. bspp
N	Fluid Inlet	3D150 and 4D150: 1 in. tri-clamp flange, 1/2 in. npt, or 1/2 in. bspp
		3D350 and 4D350: 1 in. tri-clamp flange, 3/4 in. npt, or 3/4 in. bspp
T	Compressed Air Connection	3D150 and 4D150: 1/4 in. npt
		3D350 and 4D350: 1/2 in. npt
V	Mounting holes for M10 (3/8 in.) bolts (4 required)	
AB	Muffler	

Air Line

1. Install the air line accessories as shown in [Typical Installation](#). Use adaptors as needed. Be sure the air line supplying the accessories is grounded.
 - a. The fluid pressure can be controlled with either an air regulator (F) to control the air into the pump, or with a fluid regulator (H) to control the fluid out of the pump.
 - b. Install a bleed-type master air valve (B) close to the pump. This valve is required in your system to relieve air trapped between it and the pump when the valve is closed. Be sure the bleed valve is easily accessible from the pump, and is located downstream from the air regulator.

				
Trapped air can cause the pump to cycle unexpectedly, which could result in serious injury from splashing.				

- c. Install a second air valve (E) upstream from all air line accessories to isolate them during cleaning and repair.
 - d. Install an air line filter (D) to remove contaminants such as dirt, moisture, and oil from the compressed air supply.
2. The air valve on the pump does not require lubrication.
3. Install a grounded, flexible air hose between the accessories and the pump air inlet (T). See [Technical Specifications, page 41](#), to determine the air inlet size of your pump. Use a minimum 1/2 in. (13 mm) ID air hose.
4. If desired, install an accessory Pressure Limit Kit in the air line, close to the air inlet. See [Repair Kits, page 33](#), for the correct kit for your pump size.



Fluid Suction Line



- See [Technical Specifications, page 41](#), to determine the fluid inlet size of your pump.
 - **The inlet hose must be sized so that pressure losses do not exceed 5 psi (0.4 bar) on the inlet of the pump.** Contact Graco Technical Assistance if you need help sizing the inlet hose.
1. Use flexible, conductive hoses rated for suction pressures.

2. Use a compatible liquid thread sealant on connections to prevent air from entering the fluid line.
3. Attach the suction line into the pump inlet (N) snugly.

Fluid Outlet Line

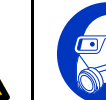
1. Use electrically conductive fluid hoses (P). Attach the fluid fitting onto the pump outlet (M) snugly while supporting the outlet with a wrench. See [Technical Specifications, page 41](#), to determine the fluid outlet size of your pump.
2. Install a fluid regulator (H) at the pump fluid outlet to control fluid pressure, if desired. See [Air Line, page 7](#), Step 1a, for an alternative method to control pressure.
3. Install a fluid drain valve (J) near the fluid outlet. To use the valve as a circulation valve, connect a tube (K) between the valve and pail.

				
A fluid drain (J) valve is required in your system to relieve pressure in the hose if it is plugged. The drain valve reduces the risk of serious injury, including splashing in the eyes or on the skin, or contamination from hazardous fluids when relieving pressure.				

				
Some systems may require installation of a pressure relief valve (not supplied) at the pump outlet to prevent overpressurization and rupture of the pump or hose.				
Thermal expansion of fluid in the outlet line can cause overpressurization. Thermal expansion can occur when using long fluid lines exposed to sunlight or ambient heat, or when pumping from a cool to a warm area (for example, from an underground tank).				
Overpressurization also can occur if the pump is used to feed fluid to a piston pump, and the intake valve of the piston pump does not close, causing fluid to back up in the outlet line.				

Remote Exhaust

If fluid pressure requirements allow it, use the 3D150 or 3D350 pumps for applications that require the pump to have a remote exhaust. Because the 4D150 and 4D350 pumps have air pressure behind the diaphragms, the restriction caused by the remote exhaust could result in shortened diaphragm life.

Breather Valve Mounting Requirements for 3D150 and 3D350 Models

3D150 and 3D350 models include two breather valves that must be mounted on the pump. The breather valves must be mounted in a vertical position to function properly. The breather valve mounting bracket allows the repositioning of the valve for the required vertical mounting.

The breather valve system indicates a breach in the diaphragm. If a breach occurs, the working fluid passes through the diaphragm to the back side of the diaphragm. Fluid then flows into the clear tubing and into the breather valve. The breather valve stops the fluid from exiting the pump.

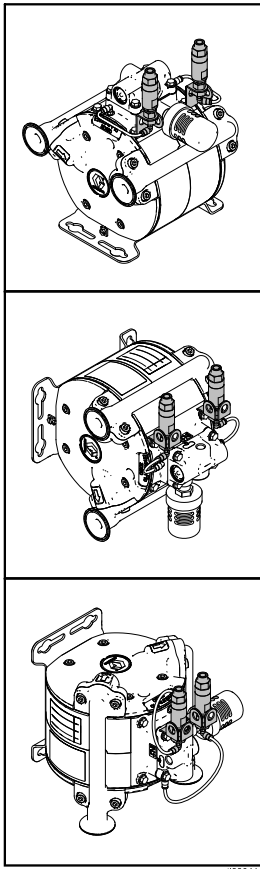
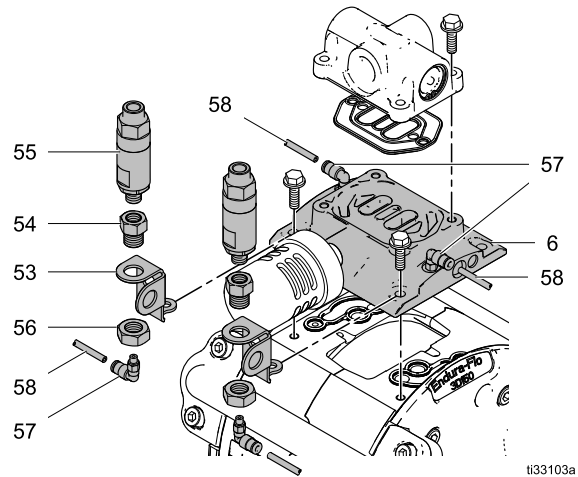

Figure 1 Possible breather valve mounting positions

Breather Valves



1. Remove the two screws on top of the pump.
2. The breather valves (55) and the valve fittings (54) are preassembled. On the muffler side, assemble the breather valves (55) to the mounting brackets (53) with the jam nut (56). Torque to 8–10 ft-lb (11–14 N•m). Thread the air fittings (57) into the valve fittings (54).

NOTE: Before assembling the breather valve system, verify clearances around the muffler and air inlet by setting up the breather valves vertically as a test. Mounting brackets have several possible breather valve mounting configurations.

3. Attach the assembly to the air manifold or air valve.

NOTE: Breather valve assemblies must be mounted and installed with the breather valve in the vertical direction for proper operation. See the illustrations in Breather Valve Mounting Requirements for 3D150 and 3D350 Models for some possible mounting configurations.

4. Connect the air tubing (58) to the air fittings (57) to complete the breather valve assembly.

Two pre-cut 4.5 in (114 mm) tubes (58) are provided for ease of installation. These tubes can be used in most mounting configurations. An additional 2 ft (610 mm) tubing section is included for applications where extra breather tube lengths are needed. These tubes can be cut to fit the configurations.

Typical Installation

The pump is sold separately from all accessories. Filters, regulators, fittings, hoses, and so on, are shown here to depict one possible system setup.

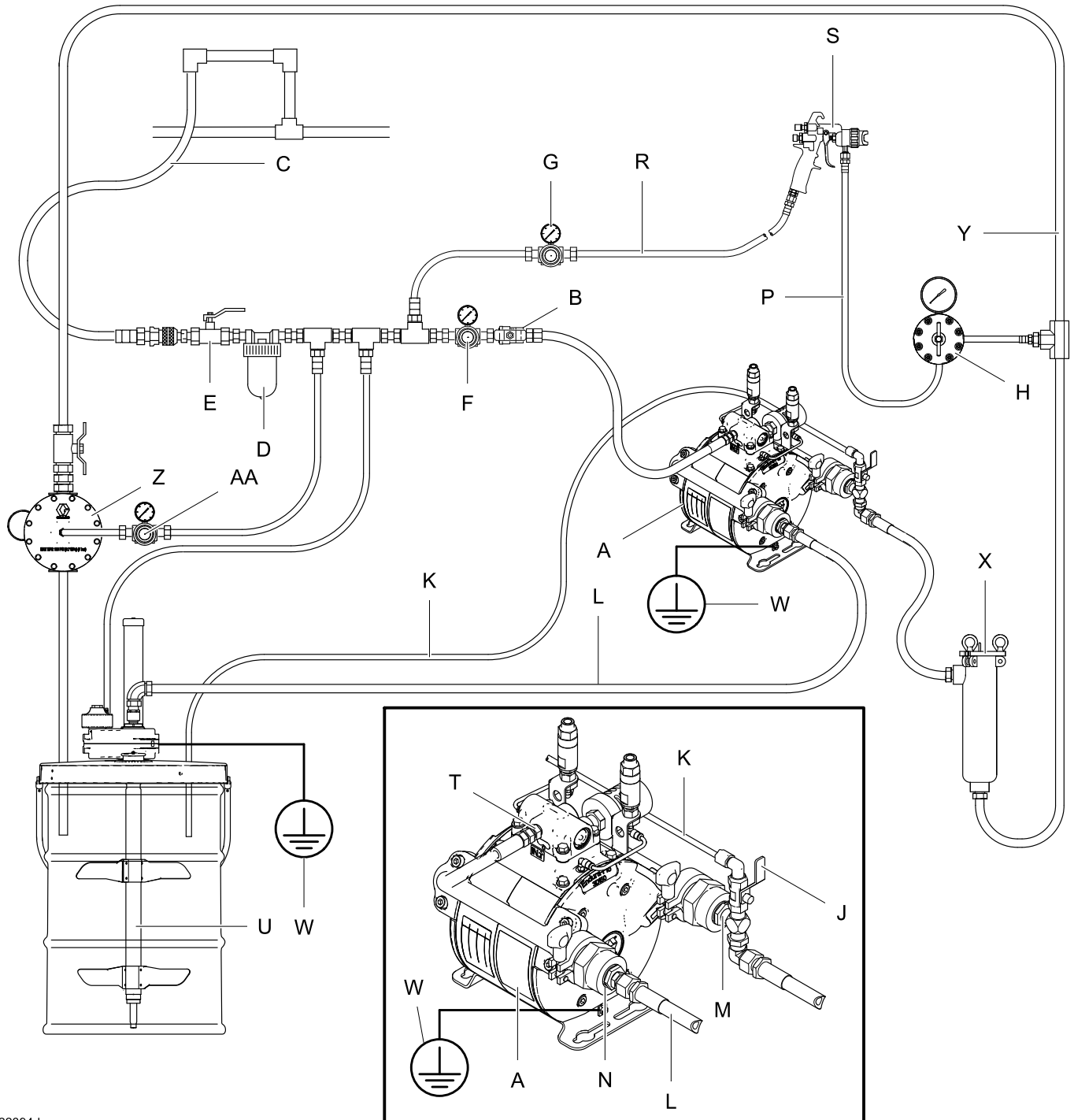



ti22394d

Installation

KEY

A	Pump	N	Pump fluid inlet
B	Bleed-type master air valve (required)	P	Fluid hose
C	Air supply line	R	Gun air hose
D	Air line filter	S	Spray gun
E	Air line shutoff valve	T	Pump air inlet
F	Pump air regulator	U	Agitator
G	Gun air regulator	W	Ground wire
H	Fluid pressure regulator	X	Fluid filter
J	Drain/circulation valve	Y	Fluid circulation line
K	Drain tube	Z	Back pressure regulator (BPR)
L	Fluid suction line	AA	BPR air regulator
M	Pump fluid outlet		

Grounding

				
<p>The equipment must be grounded to reduce the risk of static sparking. Static sparking can cause fumes to ignite or explode. Grounding provides an escape wire for the electric current.</p>				

- **Pump:** Use a ground wire and clamp. Loosen the grounding screw (X). Insert one end of a 12 ga (1.5 mm²) minimum ground wire (W) under the clamp and tighten the screw securely. Connect the other end of the wire to a true earth ground. For a ground wire and clamp, order Part No. 222011.
- **Air and fluid hoses:** Use only electrically conductive hoses.
- **Air compressor:** Follow the manufacturer's recommendations.

- **Fluid supply drum:** Follow your local code.
- **All fluid pails used when flushing:** Follow your local code. Use only conductive metal pails placed on a grounded surface. Do not place the pail on a nonconductive surface, such as paper or cardboard, which interrupts the grounding continuity.

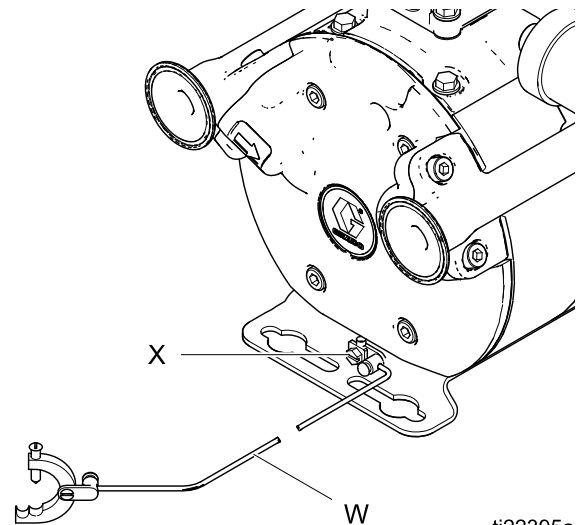

Figure 2 Ground the Pump

ti22395a

Operation

Start and Adjust the Pump

1. Be sure the pump is properly grounded. Refer to [Grounding](#), page 11.
2. Check all fittings to be sure they are tight. Be sure to use a compatible liquid thread sealant on all male threads.
3. Place the suction line (L) in the fluid to be pumped.
4. Place the end of the fluid outlet hose (P) into an appropriate container (if flushing) or connect it to a gun or other dispensing device. See [Typical Installation](#).
5. Close the fluid drain valve (J).
6. With the pump air regulator (F) closed, open the bleed-type master air valve (B).
7. If the fluid hose has a dispensing device, hold it open while continuing with the following step.
8. Slowly open the air regulator (F) until the pump starts to cycle. Allow the pump to cycle slowly until all air is pushed out of the lines and the pump is primed.

If you are flushing, run the pump long enough to thoroughly clean the pump and hoses. Close the air regulator. Remove the suction line (L) from the compatible flushing fluid and place it in the fluid to be pumped.

NOTICE

Operating the pump dry for extended periods or operating at pressures higher than the recommended maximum input air pressure may reduce diaphragm life.

Pressure Relief Procedure



Follow the Pressure Relief Procedure whenever you see this symbol.

<p>This equipment stays pressurized until pressure is manually relieved. To help prevent serious injury from pressurized fluid, such as splashing in the eyes or on skin, follow the Pressure Relief Procedure when you stop pumping and before you clean, check, or service the equipment.</p>				

1. Shut off the air supply to the pump.
2. Hold a metal part of the gun (if used) to a grounded metal pail. Trigger the gun to relieve the pressure.
3. Open all fluid drain valves in the system, having a waste container ready to catch the drainage. Leave the drain valve(s) open until you are ready to return to operation.

Pump Shutdown

Short-Term Shutdown

For a short-term shutdown, relieve the pressure (see the Pressure Relief Procedure).

Long-Term Shutdown

For a long-term shutdown, such as several hours or overnight:

1. Flush the pump thoroughly.
2. Leave compatible flushing fluid in the pump.
3. Relieve the pressure (see the Pressure Relief Procedure).

Maintenance

Lubrication

The pump is lubricated at the factory. It is designed to require no further lubrication for the life of the pump.

NOTICE

Do not over-lubricate the pump. Oil is exhausted through the muffler and could contaminate your fluid supply or other equipment. Excessive lubrication can also cause the pump to malfunction.

Flushing and Storage

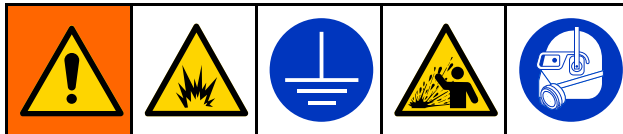

To avoid fire and explosion, always ground equipment and waste container. To avoid injury from splashing and static buildup, always flush at the lowest possible pressure.

- Flush the pump often enough to prevent the fluid you are pumping from curing, drying, or freezing in the pump and damaging it.
- Flush with a fluid that is compatible with the fluid you are pumping and with the equipment wetted parts.

- Flush the pump and follow the [Pressure Relief Procedure, page 12](#), before storing the pump.

Flush procedures vary widely by system requirements. See [Start and Adjust the Pump, page 12](#), for one common method of flushing. If your system is different, or if you are unsure how to completely flush your system, contact your Graco distributor.

Tighten Threaded Connections

1. Before each use, check all hoses for wear or damage, and replace as necessary.
2. Check to be sure all threaded connections are tight and leak-free.

Preventive Maintenance Schedule

Establish a preventive maintenance schedule based on the service history of the pump. Scheduled maintenance is especially important to prevent spills or leakage due to diaphragm failure in 4D150 and 4D350 pumps.

Troubleshooting

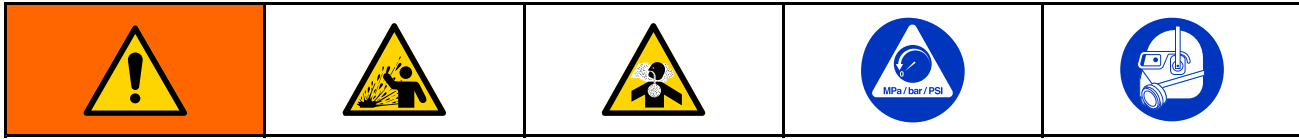

- Follow the [Pressure Relief Procedure, page 12](#), before checking or servicing the equipment.
- Check all possible problems and causes before disassembly.

Problem	Cause	Solution
The pump cycles at stall or fails to hold pressure at stall.	The check valve cartridges (9) are worn.	Replace the check valve cartridges (9).
	The outlet fluid valve is worn.	Replace the outlet fluid valve.
	The diaphragm (18) is worn.	Replace the diaphragm (18).
The pump will not cycle, or cycles once and stops.	The air valve is stuck or dirty.	Disassemble and clean the air valve. Use filtered air.
	The check valve cartridges (9) are worn.	Replace the check valve cartridges (9).
	The fluid dispensing valve is clogged.	Relieve the pressure and clear the valve.
	The fluid hose line is pinched.	Check the lines.
	The diaphragm plate (21) is installed backwards.	Follow the installation directions in Install the Diaphragms, page 25 .
	The checks are not installed properly.	Follow the installation directions in Install the Fluid Manifolds, page 26 .
	The pilot valves (12) are not working.	Replace the pilot valves (12).
The pump operates erratically.	The suction line is clogged.	Inspect and clear the suction line.
	The check valves are sticky or leaking.	Clean or replace the check valve cartridges (9).
	Diaphragm (18) is ruptured.	Replace the diaphragm (18).
	Exhaust is restricted.	Remove the restriction.
	Checks are not installed properly.	Follow the installation directions in Install the Fluid Manifolds, page 26 .
The fluid contains air bubbles.	The suction line is loose.	Tighten the suction line.
	The diaphragm (18) is ruptured.	Replace the diaphragm (18).
The pump is running irregularly. The stroke frequency is dropping, coming to a standstill.	The diaphragm (18) is ruptured or the pump has worn parts.	Replace worn parts. Check the compressed air supply.
	The pump is icing. Possible causes include: compressed air too moist, stroke frequency too high, local temperature too low.	Remove the ice by changing the operating conditions.

Problem	Cause	Solution
Air escapes continually from the muffler.	The air valve cup (112) is damaged.	Replace damaged parts.
	Foreign matter is inside the pump.	Check the air filter.
	The shaft seals (26) are worn.	Replace the shaft seals (26).
The pump does not start, or pressure fluctuates.	The check valve cartridges (9) are worn.	Replace the check valve cartridges (9).
	The inlet strainer is blocked. The maximum suction is exceeded. The hose or seal is defective.	Clean the strainer. Replace defective parts.
	The fluid is contaminated. The pump was installed or operated incorrectly.	Check the fluid supply. Follow the installation and operation instructions in this manual.
	Checks are not installed properly.	Follow the installation directions in Install the Fluid Manifolds, page 26 .

Repair/Service

Repair or Replace the Air Valve

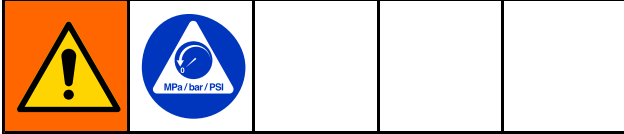

NOTE: If the breather valve (55) has been contaminated with paint, you must replace the breather valve. Clogged paint will cause the breather valve not to work. Purchase and install part 17J564. In addition, clear the vent pathways of clogged paint and replace clogged components as needed.

Replace the Complete Air Valve

1. Stop the pump. Follow the [Pressure Relief Procedure, page 12](#).
2. Disconnect the air line.
3. **For models with DataTrak:** Remove the screw to disconnect the reed switch assembly from the air valve. Then, remove two screws and the solenoid bracket. Pull the solenoid out of the air valve.

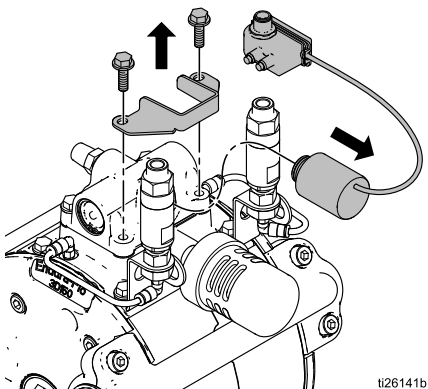
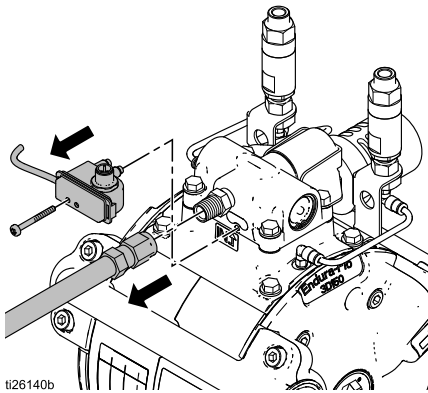

3D150 Models Shown

4. Remove the screws (17). Remove the air valve (1) and the gasket (13).
5. To repair the air valve, see [Replace Seals or Rebuild the Air Valve, page 17](#).
6. Align the new air valve gasket (13) on the manifold, then attach the new or repaired air valve. See [Torque Instructions, page 27](#).
7. **For models with DataTrak:** Remember to reattach the solenoid bracket and the solenoid. Then, use the screw to attach the reed switch assembly to the new air valve. Reconnect the cable.
8. Reconnect the air line.

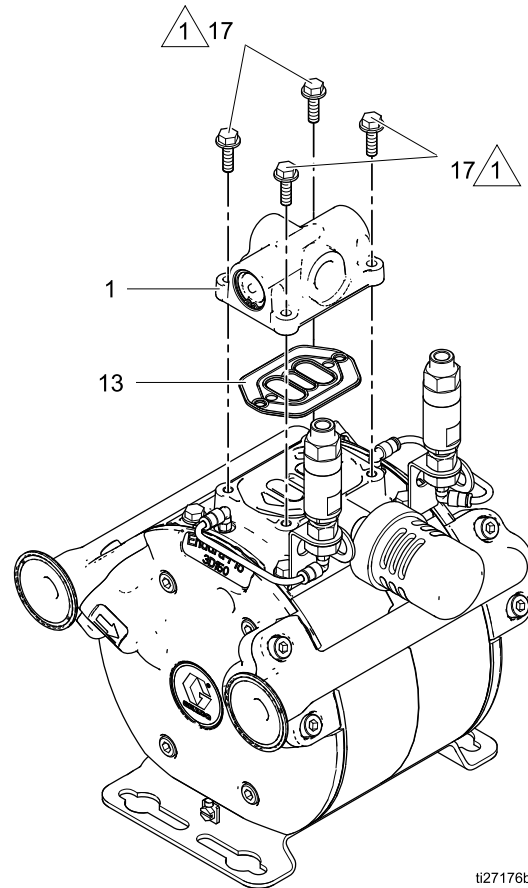

 Torque to 100–120 in-lb (11–14 N•m).

3D150 Model Shown

Replace Seals or Rebuild the Air Valve

See [Repair Kits, page 33](#), to find the correct repair kits for your pump. Parts in Air Valve Seal Kits are marked †. Parts in Air Valve Repair Kits are marked ◆. Parts in End Cap Kits are marked ❖.

Disassemble the Air Valve

1. Perform steps 1–4 under [Replace the Complete Air Valve, page 16](#).
2. Use a T8 Torx screwdriver to remove two screws (109). Remove the valve plate (105), the cup (112, 3D150 and 4D150 models) or the cup assembly (112–114, 3D350 and 4D350 models), the spring (111), and the detent assembly (103).
3. **3D350 and 4D350 Models:** Pull the cup (112) off of the base (114). Remove the o-ring (113) from the cup.
4. Remove the retaining ring (110) from each end of the air valve. Use the piston (102) to push the end caps (107, 117) out of the ends. Remove the end cap o-rings (106). If the pump model is equipped with DataTrak, also remove the solenoid release button (118) and o-ring (119).
5. Remove the u-cup seals (108) from each end of the piston (102), then remove the piston. Remove the detent cam (104) from the air valve housing (101).

Reassemble the Air Valve

NOTE: Apply lithium-based grease whenever instructed to grease.

1. Use all parts in the repair kits. Clean other parts and inspect for damage. Replace as needed.
2. Grease the detent cam (104) and install it into the housing (101).

3. Grease the u-cups (108) and install on the piston with the lips facing toward the center of the piston.

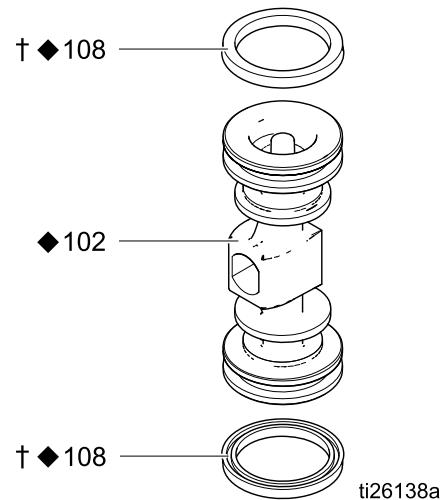

4. Grease both ends of the piston (102) and install it in the housing (101), with the flat side toward the cup. Be careful not to tear the u-cups (108) when sliding the piston into the housing.
5. **Standard Models:** Grease the new o-rings (106) and install them on the end caps (107). Install the end caps into the housing.
DataTrak Models: Orient the air valve so the air inlet faces forward. Grease and install the new o-ring (106) on the right-side end cap (107). Grease and install the new o-ring (106) and the solenoid release button (118) and o-ring (119) on the left-side end cap (117). Install the end caps into the housing.
6. Install a retaining ring (110) on each end to hold the caps in place.
7. Grease and install the detent assembly (103) into the piston.

Air Valve Disassembly or Reassembly

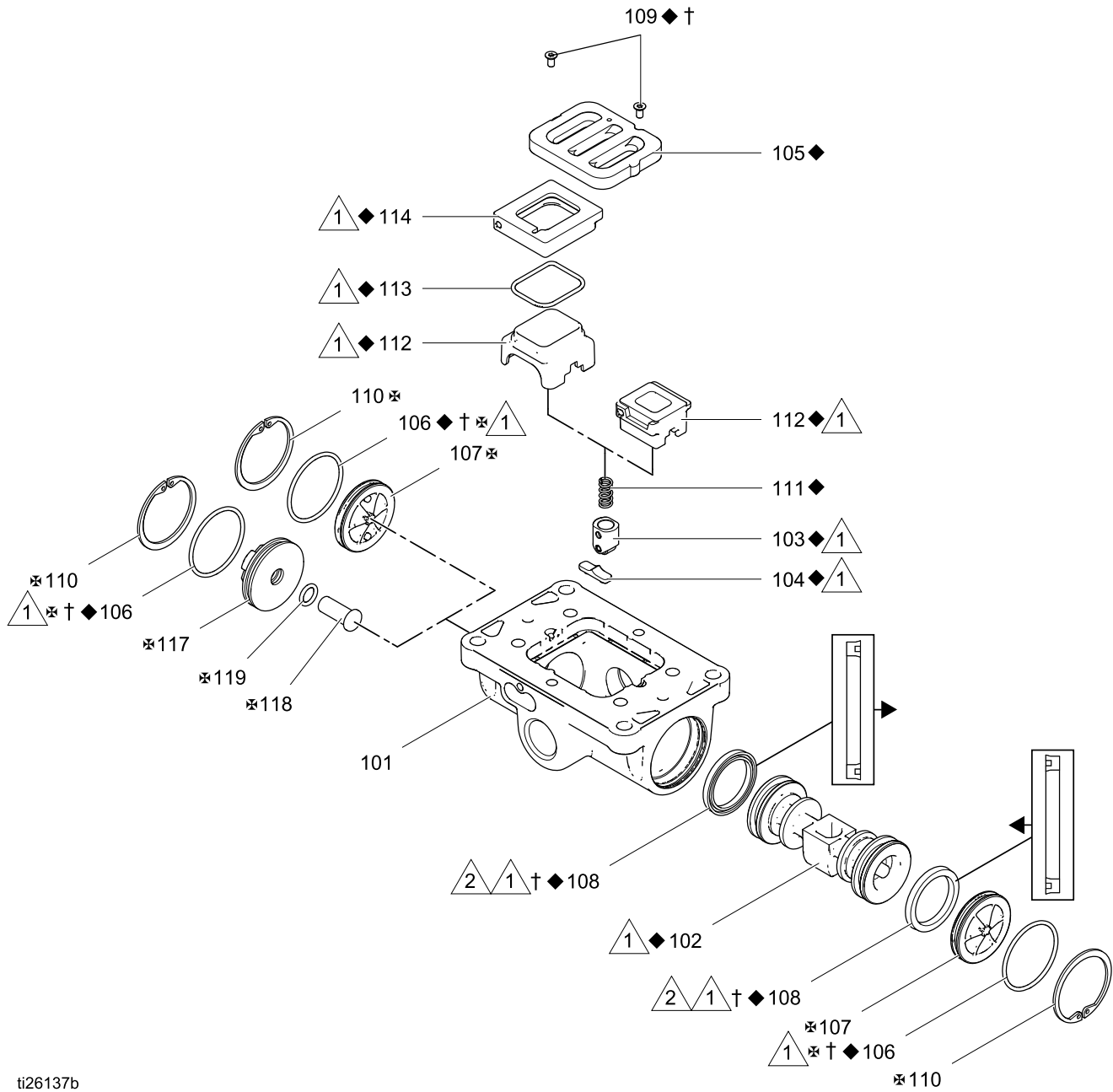

ti26137b



Apply lithium-based grease.



U-cup lips must face the piston.

8. **3D150 and 4D150 Models:**

- a. Install the spring (111).
- b. Grease the side of the air valve cup (112) that will contact the valve plate (105).
- c. Install the air valve cup (112).
- d. Align the small round magnet (B) with the air inlet.

9. **3D350 and 4D350 Models:**

- a. Install the o-ring (113) on the cup (112).
- b. Apply a light film of grease to the outside surface of the o-ring and the inside mating surface of the base (114).
- c. Orient the end of the base that has a magnet toward the end of the cup that has the larger cutout. Engage the opposite end of the parts. Leave the end with the magnet free.
- d. Tilt the base toward the cup and fully engage the parts, using care so that the o-ring remains in place.
- e. Install the spring (111) onto the protrusion on the cup. align the magnet in the base with the air inlet and install the cup assembly.

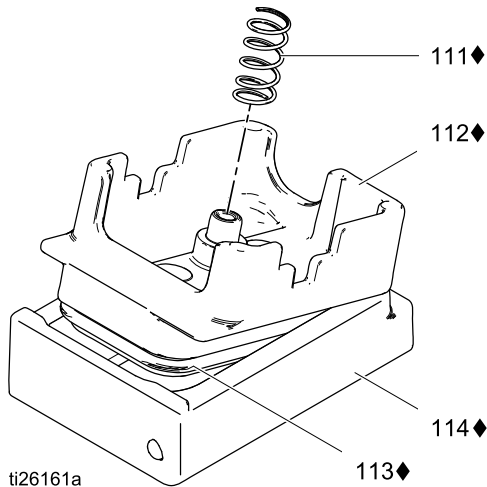

10. Grease the cup side, and install the valve plate (105). Align the small hole (A) in the plate with the air inlet. Tighten the screws (109) to hold it in place.

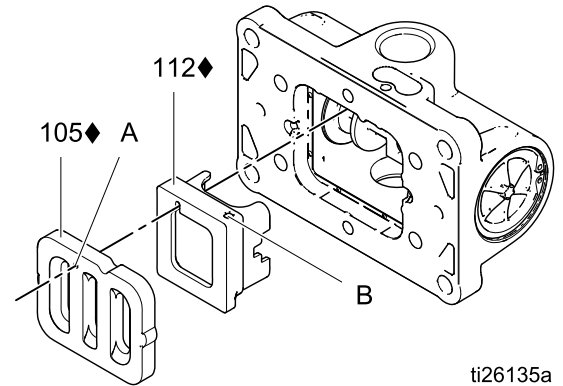

DataTrak

NOTE: See the DataTrak manual 313840 for all DataTrak service, repair, and operation information.

Replace DataTrak Battery or Fuse

<p>To reduce the risk of fire and explosion, the battery and fuse must be replaced in a non-hazardous location. Follow all instructions in the DataTrak manual 313840.</p> <p>Use only an approved replacement battery and an approved fuse (see the DataTrak manual). Use of an unapproved battery or fuse will void Graco's warranty and Ex approvals.</p>				

Disassemble the Fluid Section

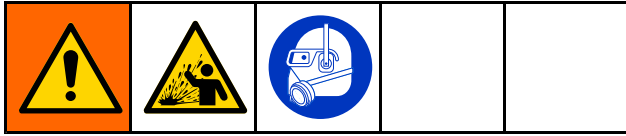

1. Stop the pump. Follow the [Pressure Relief Procedure, page 12](#).
2. Use a hex socket wrench (6 mm for 3D150 and 4D150 models; 8 mm for 3D350 and 4D350 models) to remove the inlet and outlet fluid manifold bolts (16). Remove the fluid manifolds (2).
3. Remove the check valve cartridges (9).
4. Do not remove the manifold o-rings (38) yet.
5. Use a hex socket wrench (6 mm for 3D150 and 4D150 models; 8 mm for 3D350 and 4D350 models) to remove the bolts (15) from one fluid cover (4). Remove the fluid cover.

Fluid Section Disassembly or Reassembly (3D150 Model Shown)

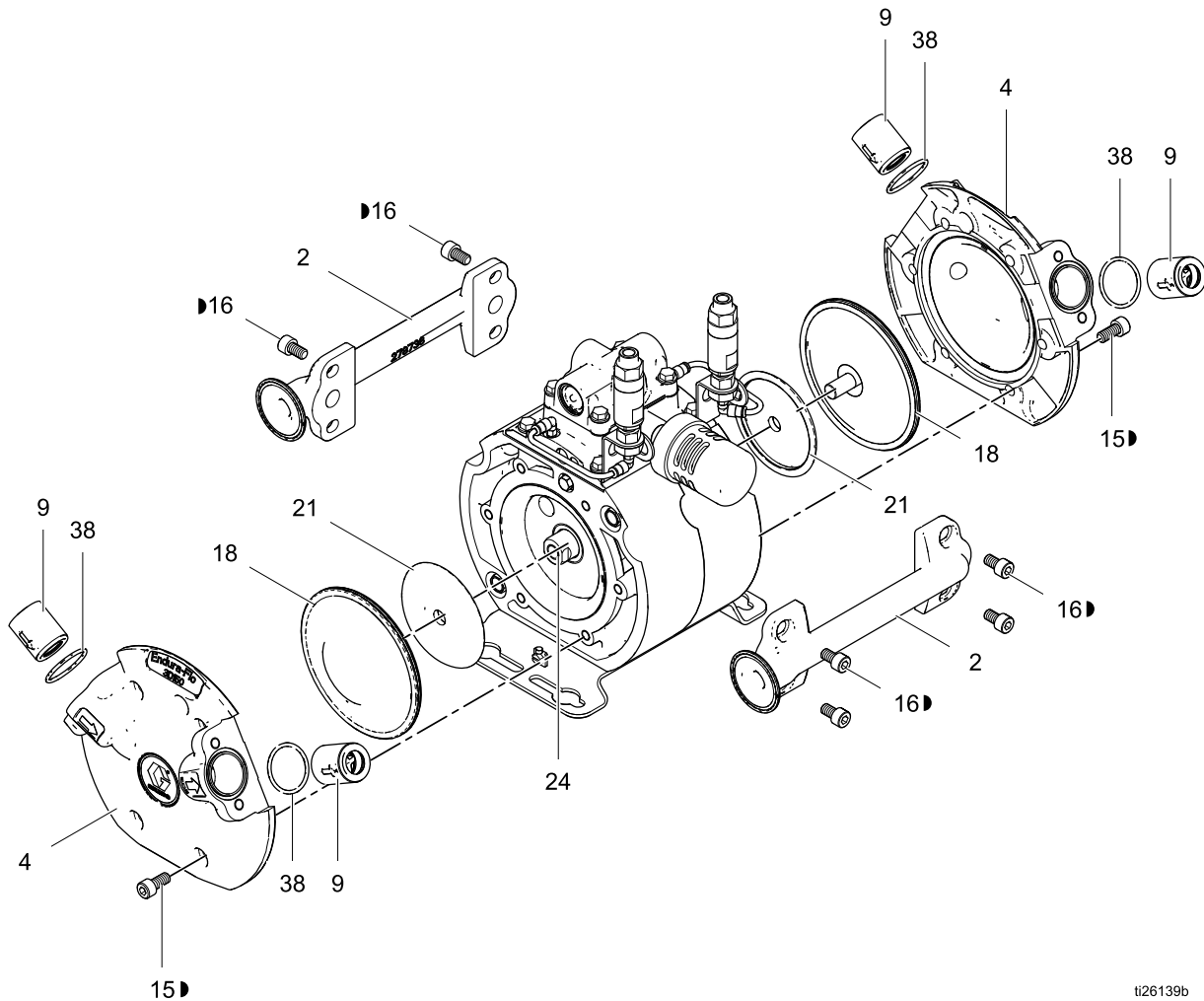

ti26139b

► Included in Fluid Section Fastener Kit 17H325.

6. The replacement diaphragm kit includes two air plate tools (AC) and a plug (AD). These parts provide an air assist to make it easier to remove the diaphragms.
7. Place an air plate tool on both the inlet and outlet ports. Install an air fitting (1/8 in. npt) on one tool. Install a plug (AD) on the other tool.
8. Supply shop air at about 20 psi (0.14 MPa, 1.4 bar). Do not use over 30 psi (0.21 MPa, 2.1 bar). The shaft will move to one side.
9. Grasp the exposed diaphragm (18) with both hands and turn to remove it.
NOTE: To make it easier to remove the diaphragm, use the diaphragm removal tool (not shown) included with the Diaphragm Kit. Diaphragm removal tools are also available to order separately. For more information, see [Repair Kits, page 33](#).
10. Remove the diaphragm plate (21) and the washer (40, used only on 3D350 and 4D350 models) from the diaphragm.
11. Leave the air on. Use a 3/4 in. claw foot wrench to loosen the piston shaft (24) attached to the other diaphragm.
NOTE: If paint has entered the air section, the piston o-ring (28) may swell. When this occurs, it is difficult to remove the second diaphragm by turning the shaft. An alternative method is to remove the mounting bracket (5) and air manifold (6). Then, remove the air cover bolts (10) and separate the air covers (7). Keep the diaphragm secured with the fluid cover and turn the exposed pump shaft to remove the second diaphragm.
12. Remove compressed air pressure.
13. Use a hex socket wrench (6 mm for 3D150 and 4D150 models or 8 mm for 3D350 and 4D350 models) to remove the bolts (15) from the other fluid cover (4). Remove the cover.
14. Turn off the second diaphragm (18) by hand. Remove the diaphragm plate (21) and the washer (40, used only on 3D350 and 4D350 models).

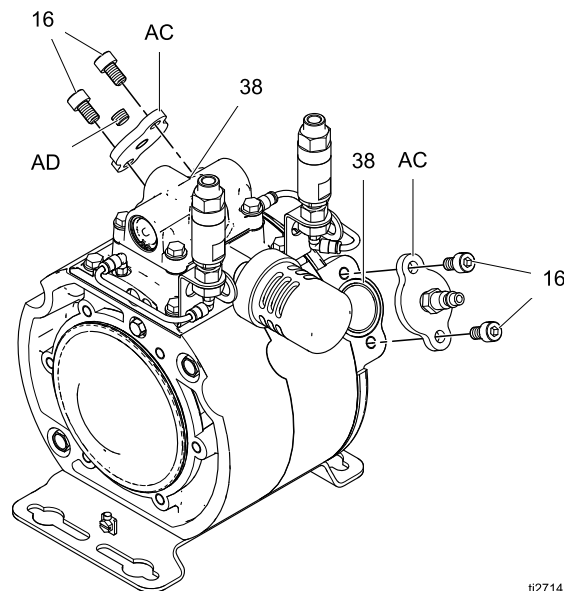

t127141b

3D150 Model Shown

Disassemble the Center Section

1. Use a 10 mm socket wrench to remove the four bolts (17), then remove the air manifold (6). If the air valve (1) doesn't need service, leave it attached to the air manifold.
2. Inspect the manifold gaskets (13, 14) for damage. Remove if necessary.
3. Use a 10 mm socket wrench to remove the four bolts (17), then remove the mounting bracket (5).
4. The pilot valves (12) can remain in place unless they are damaged. If needed, use a 10 mm socket wrench to remove the pilot valves.
5. Use a 13 mm socket wrench to remove the bolts (10), then remove the air covers (7).
6. Pull the piston (20) out of the cylinder (27). Remove the o-ring (28) from the piston.
7. Remove the cylinder (27) and inspect for damage.
8. Inspect the air cover o-rings (29). Remove if necessary.
9. Inspect the shaft u-cup seals (26) and L-cup seals (52, used only on 3D150 and 3D350 models). Remove if necessary. The shaft bearings (23) can remain in place. If the bearings are damaged and need to be removed, use a screwdriver or a large punch to push them out from the other side.
10. Inspect the bumpers (22) in place. If damaged, use a flathead screwdriver to pry up the three tabs of the bumper. The bumper should then pop out.

NOTE: The air covers should pop apart by hand. If necessary, pry them apart with a screwdriver.

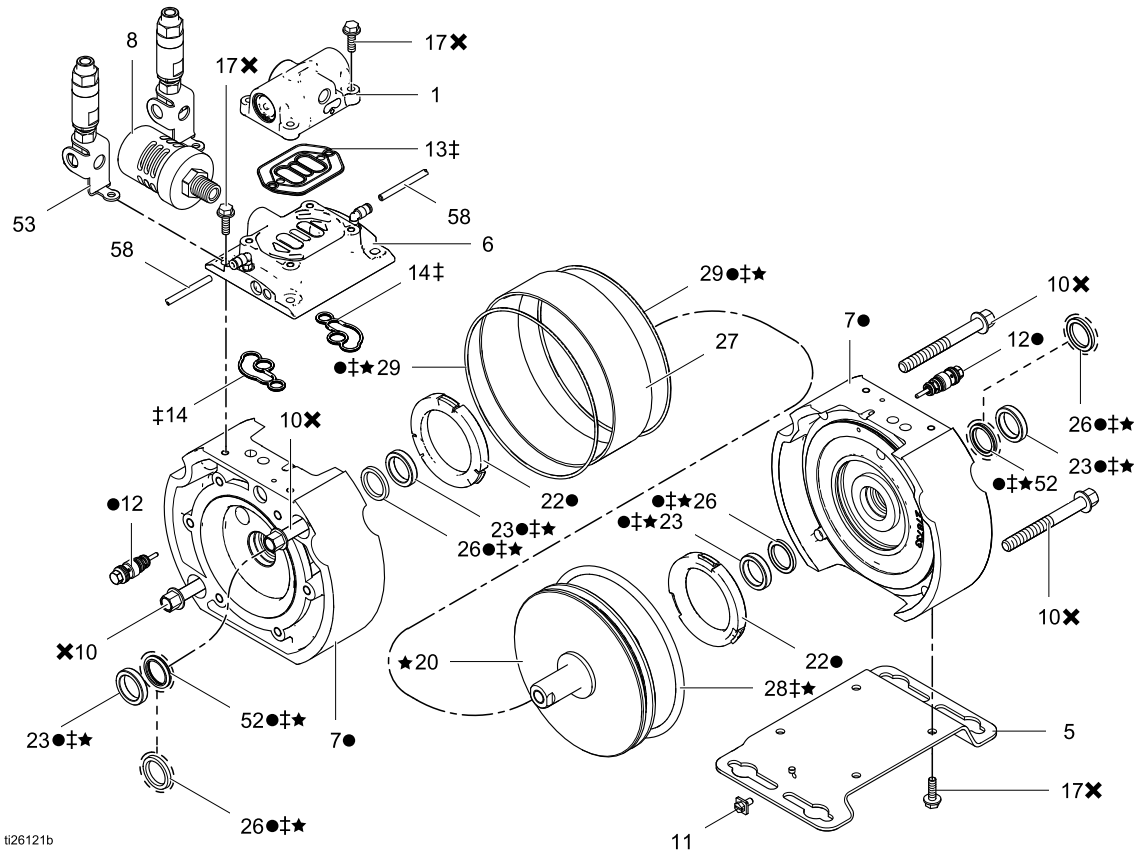

● Included in Air Cover Replacement Kit 17H312.

‡ Included in Air Motor Repair Kit 17H305.

✕ Included in Air Section Fastener Kit 17H327.

★ Included in Piston Repair Kit 17H310. The kit also includes a bearing installation tool.

3D150 Model Shown

Reassemble the Center Section

1. For 3D150 and 3D350 models, install the new L-cup o-ring seals (52) into the outside face of the air cover shaft, with the o-ring portion of the seal facing the outside of the pump.
2. For 3D150 and 3D350 models, lubricate and install a u-cup (26) in the air cover (7). For 4D150 and 4D350 models, install two u-cups (26), one in each air cover (7). The u-cup lips must face outward.
3. If the shaft bearings (23) were removed, install new bearings. Use an arbor press or the bearing press tool supplied with the kits (PN 17H368).
4. Lubricate and install an o-ring (29) in each air cover.
5. The piston assembly should still be one piece. If the two shafts came apart during disassembly, follow these instructions to reassemble.
 - a. The shaft stud will be attached to one shaft. Clean the threads and apply primerless, high-strength (red) thread locker (Loctite® 263 or equivalent).
 - b. Install the shafts in the center of the piston and hand tighten them together.
 - c. Clamp the flats of one shaft in a vice, and torque the other shaft to 50–55 ft-lb (68–75 N•m).

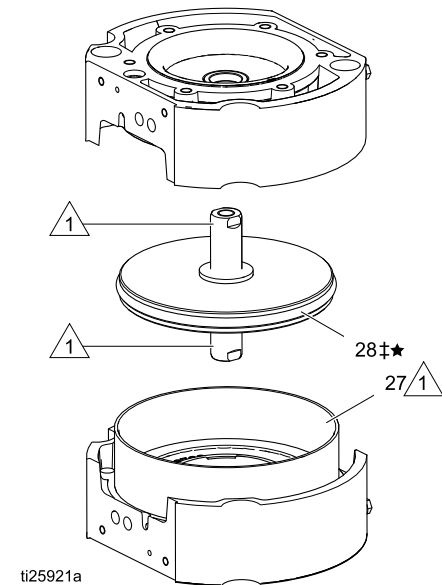
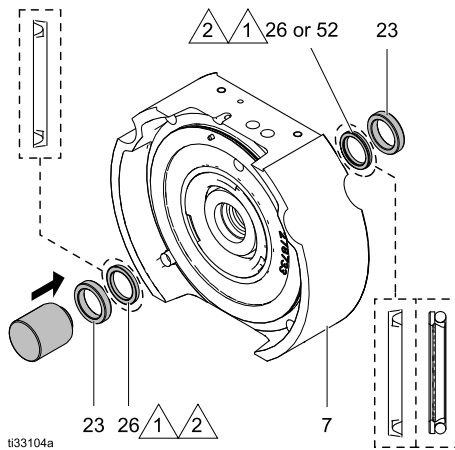

- 1 Apply lubricant.
- 2 U-cup lips and L-cup seals must face outward.

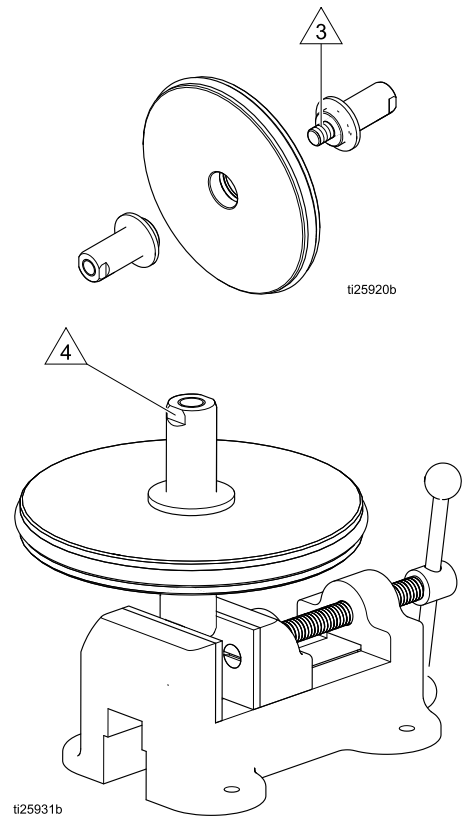

- 3 Apply high-strength (red) thread locker (Loctite® 263 or equivalent) to the threads. *NOTE: Loctite® is a registered trademark of the Henkel Corporation. All other brand names or marks are used for identification purposes and are trademarks of their respective owners.*
- 4 Torque to 50–55 ft-lb (68–75 N•m).

Repair/Service

6. Lubricate and install the large o-ring (28) on the outside of the piston.
 7. Lubricate the mating surface and install the cylinder (27) on one of the covers.
 8. Lubricate the outer o-ring (28), the inside of the cylinder (27), the shaft, and the shaft bearings (23). Then, install the piston assembly (20) in the cylinder (27). Add more lubricant on the inside of the cylinder above the piston, so the piston moves freely back and forth.
 9. Align the second air cover (7) and press it down over the cylinder and piston. Use a 13 mm socket wrench to tighten the bolts (10) on each air cover. Torque to 28–33 ft-lb (38–45 N•m). Torque the first cover, then the second cover, then go back and torque the first cover again.
- NOTE:** Check the shaft to be sure it moves freely in both directions.
10. Lubricate and install new pilot valves (if removed). Torque to 100–120 in-lb (11–14 N•m).

NOTICE

To avoid damage to the pilot valve, do **not** overtorque.

11. Use four bolts (17) to attach the mounting base (5) to the pump. It can be parallel to or perpendicular to the length of the pump. Torque the bolts to 100–120 in-lb (11–14 N•m).
12. If the breather valve (55) was contaminated, assemble the new breather valve assembly according to the instructions in the [Breather Valves, page 8](#) section.

NOTICE

If the breather valve (55) has been contaminated with paint, you must replace the breather valve. Clogged paint will cause the breather valve not to work. Purchase and install part 17J564. In addition, clear the vent pathways of clogged paint and replace clogged components as needed.

13. Make sure the gaskets (14) are still in place, or lubricate and install them, then align and reinstall the air manifold (6). Torque the bolts (17) to 100–120 in-lb (11–14 N•m).

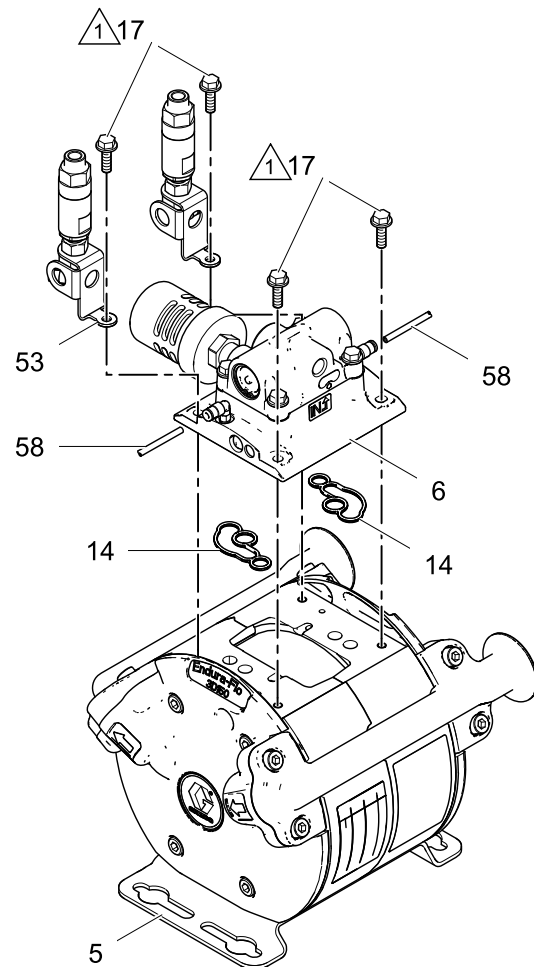

ti26115b

 Torque to 100–120 in-lbs (11–14 N•m).

3D150 Model Shown

Reassemble the Fluid Section

Follow all notes in the illustrations. These notes contain important information.

Install the Diaphragms

1. Assemble a diaphragm plate (21) onto each diaphragm (18). The rounded side of the plate must face the diaphragm.
2. **3D350 and 4D350 Models:** Install a washer (40) in each diaphragm plate.
3. Apply primerless, removable (blue) thread locker (Loctite 243 or equivalent) to the internal (shaft) threads of one diaphragm assembly. Screw the assembly into the shaft as tight as possible by hand.

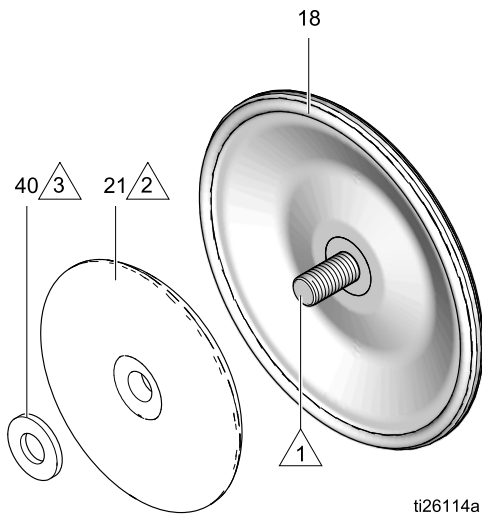

- 1 Apply removable (blue) thread locker to the internal (shaft) threads.
- 2 Rounded side must face the diaphragm.
- 3 Washers are used on 3D350 and 4D350 models only.

4. Align and attach the fluid cover to lock the diaphragm in place. **NOTE:** Use the fluid cover that has the diaphragm installation plates (AC) attached to the inlet and outlet ports. See [Disassemble the Fluid Section, page 20](#) and [Repair Kits, page 33](#). To tighten the bolts, see [Torque Instructions, page 27](#).

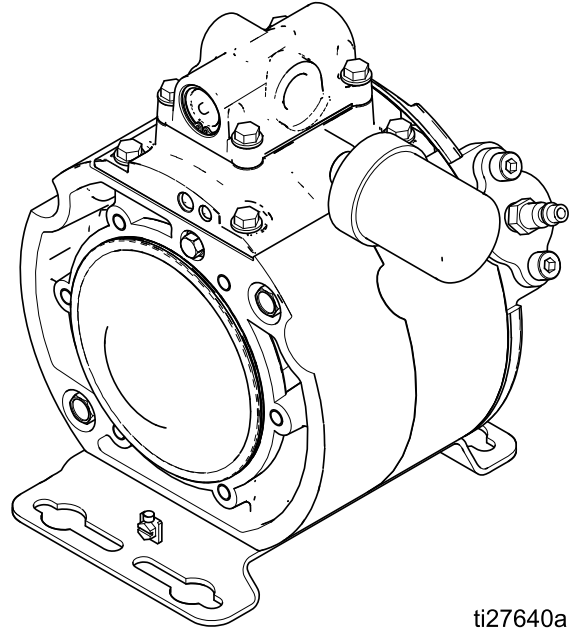

4D150 Model Shown

5. Supply shop air at about 20 psi (0.14 MPa, 1.4 bar). Do not use over 30 psi (0.21 MPa, 2.1 bar). The shaft will move to one side.
6. Torque the exposed shaft to 100–120 in-lb (11–14 N•m) using a 3/4 in. claw foot wrench.
7. Leave the air on. Install the other diaphragm assembly (diaphragm, air plate, and washer, if used). Use both hands and install as tight as possible by hand.
8. Remove the air line. Align and attach the second fluid cover. To tighten the bolts, see [Torque Instructions, page 27](#).
9. Remove the diaphragm installation plates (AC) and the o-rings (38).

Install the Fluid Manifolds

1. Install new o-rings (38) on the two inlet and two outlet ports.
2. Align the arrow on the check cartridge (9) with the arrow on the port. Install a new check cartridge in each inlet and outlet port.
3. The manifolds are identical, but it is likely that the inlet and outlet manifold will have different fittings. Install the inlet manifold (2) on the ports that have the arrow facing in toward the pump. Install the outlet manifold (2) on the ports that have the arrow facing out away from the pump. Start all screws (16), then see [Torque Instructions, page 27](#).

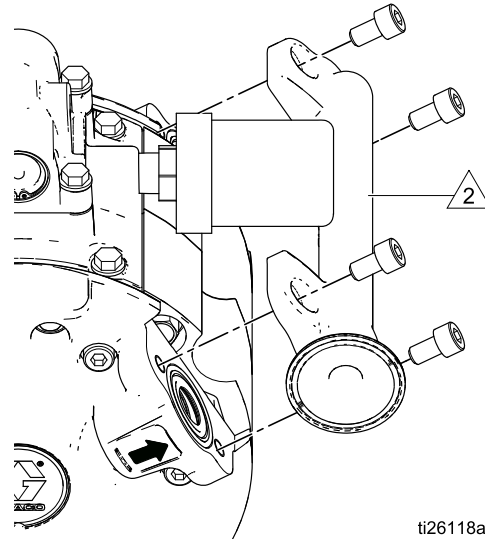
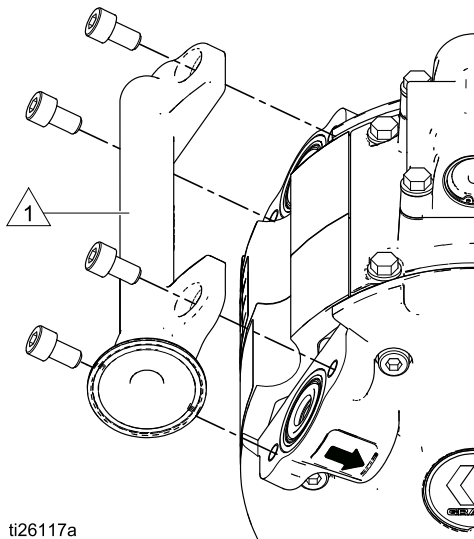
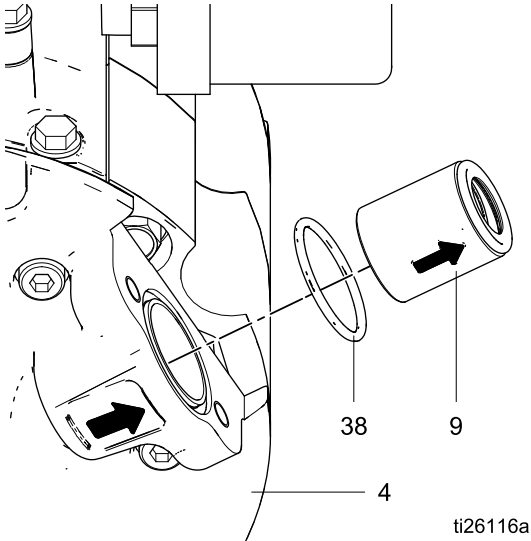

Inlet manifold.



Outlet manifold.

Torque Instructions

If fluid cover or manifold fasteners have been loosened, it is important to torque them using the following procedure to improve sealing.

NOTE: Always completely torque the fluid covers before torquing the manifolds.

1. Tighten all fluid cover screws in the specified crisscross pattern. Repeat the pattern to tighten to the specified torque.

3D150 and 4D150 Models: 20–25 ft-lb
(27–34 N•m)

3D350 and 4D350 Models: 28–33 ft-lb
(38–45 N•m)

2. Repeat for fluid manifolds. Torque to:

3D150 and 4D150 Models: 20–25 ft-lb
(27–34 N•m)

3D350 and 4D350 Models: 28–33 ft-lb
(38–45 N•m)

3. Retorque the air valve and air valve manifold fasteners in a crisscross pattern to 100–120 in-lb (11–14 N•m).

4. Retorque the pilot valves to 100–120 in-lb (11–14 N•m).

Torque Sequence

Fluid Cover Screws

3D150 and 4D150 Models (4D150 Model Shown)

3D350 and 4D350 Models (4D350 Model Shown)

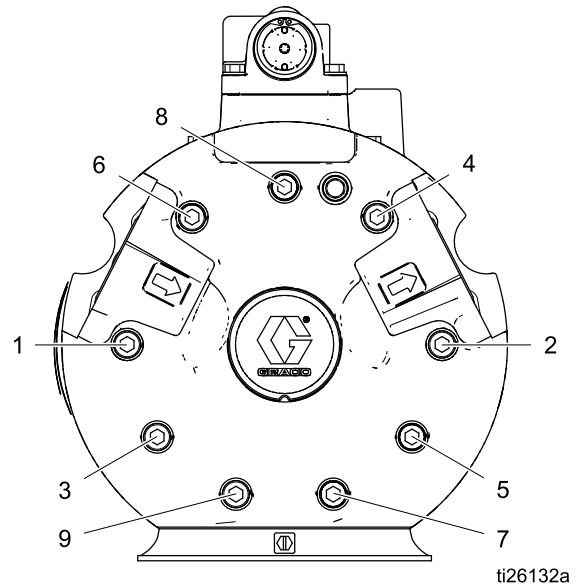
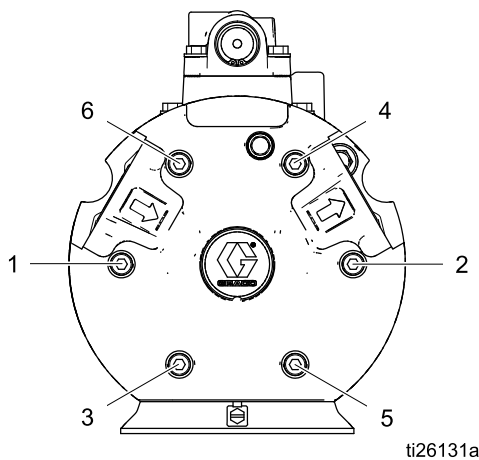

Manifold Fasteners

Air Valve and Air Valve Manifold Fasteners

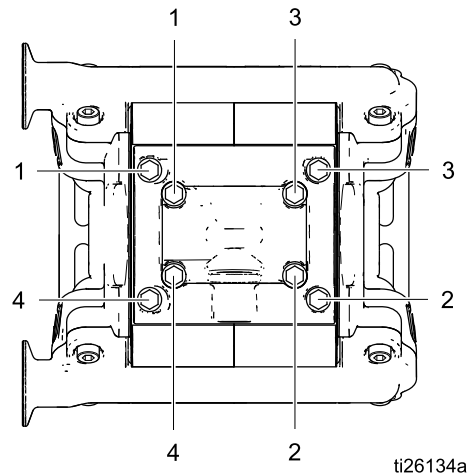
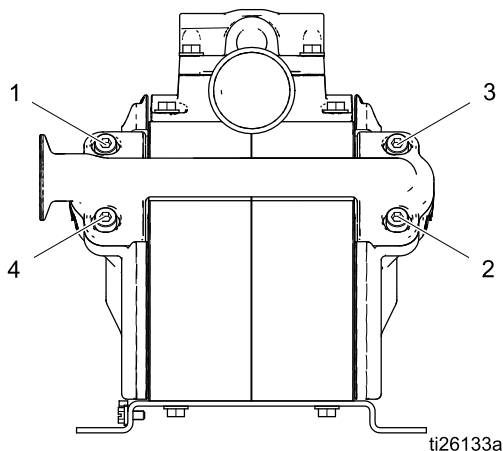

Parts

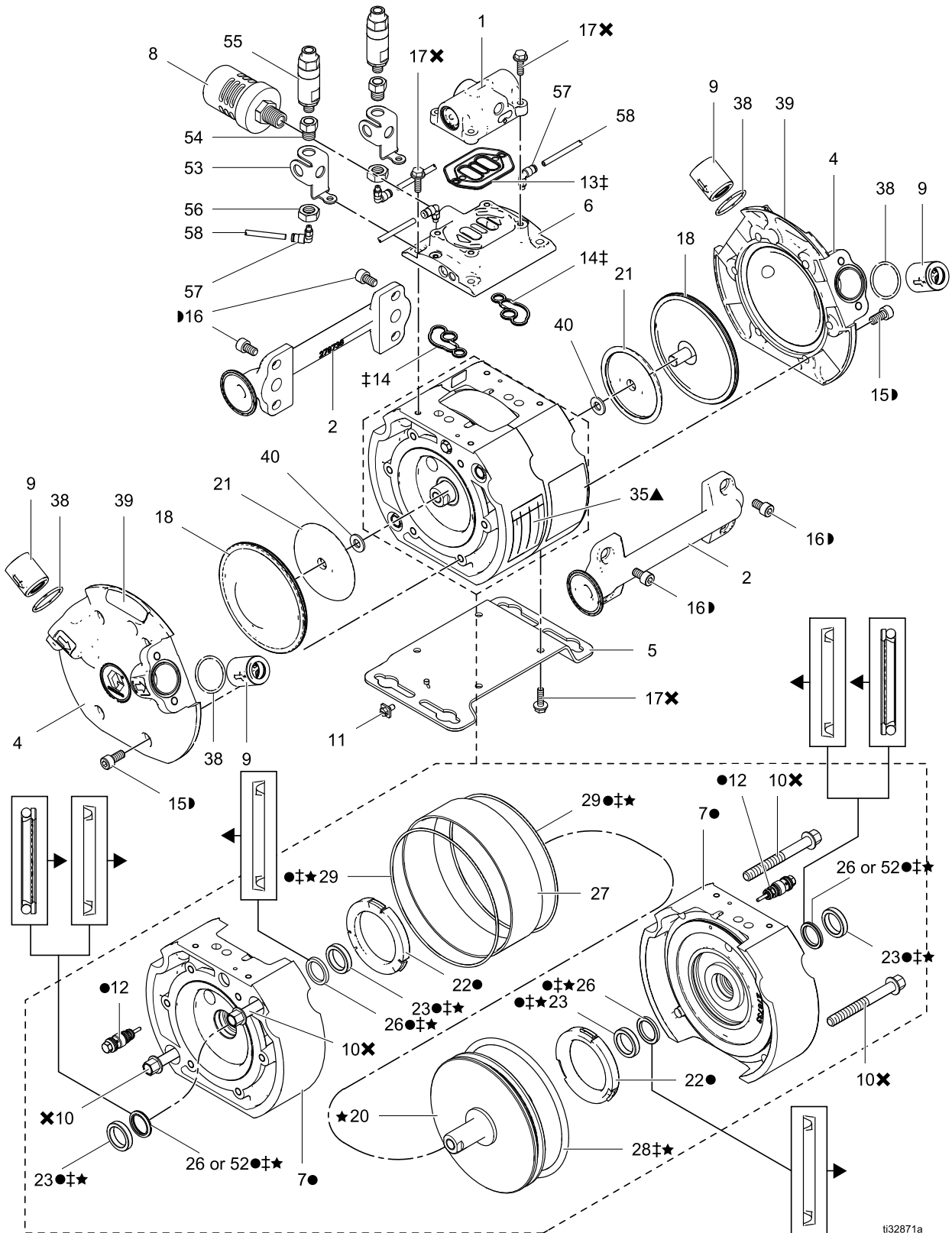

t32871a

3D150 and 4D150 Models

Ref	Part	Description	Qty
1	17H318 17H319	VALVE, air; small; includes gasket (13) and screws (17) Smart (for use with DataTrak) Standard	1
2	16X052 16X100 17C115	MANIFOLD, fluid Tri-Clamp npt bspp	2
3	24Y304	DATATRAK KIT; used for models 25M742, 25M743, 25M744, 24W348, 24W349, and 24W350; includes air valve 17H318	1
4	17H408	COVER, fluid	2
5	17H313	BRACKET, mounting, kit; includes ground screw (11) and screws (17)	1
6	24W363 25D842	MANIFOLD, air MANIFOLD, air ◆	1
7●	17H311	AIR COVER KIT	2
8	17B922	MUFFLER	1
9	17H306	CARTRIDGES, check valve; 4-pack; includes o-rings (38). <i>See Alternative Check Valve Kit, page 34 for a kit with carbide seats.</i>	1
10✘	— — —	SCREW, hex head, M10–1.5 x 90 mm	4
11	116343	SCREW, ground	1
12●	24A366	VALVE, pilot, 2-pack	1
13‡	— — —	GASKET, air valve, buna-n; also included with air valve (1)	1
14‡	— — —	GASKET, air manifold, buna-n	2
15▷	— — —	SCREW, socket head, M8–1.25 x 18 mm	12
16▷	— — —	SCREW, socket head, M8–1.25 x 14 mm	8
17✘	— — —	SCREW, hex flange, M6–1.0 x 20 mm; also included with air valve (1), mounting bracket (5), and DataTrak (3)	12

Ref	Part	Description	Qty
18	17H302	DIAPHRAGM, overmolded, kit; includes 2 diaphragms, diaphragm replacement tools, and o-rings (38)	1
20★	17H308	PISTON ASSEMBLY, kit	1
21	16W972	PLATE, diaphragm	2
22●	24A914	BUMPER, 2-pack	1
23● ‡ ★◆	— — —	BEARING, shaft	4
26● ‡ ★	112181	U-CUP, shaft, 3D pumps U-CUP, shaft, 4D pumps	2 4
27	16W969	CYLINDER, piston	1
28‡ ★	15F458	O-RING, piston, buna-n, 6 in. (152 mm) OD	1
29● ‡ ★	15F449	O-RING, air covers	2
35▲	188621	LABEL, warning	1
38	17H322	O-RING, manifold, 4-pack; PTFE, also included in check valve cartridge (9) and diaphragm (18)	1
39	17V591 17D583	LABEL, branding, 150cc	2
52◆	25D846	L-CUP, o-ring seal	2
53◆	17V754	BRACKET, mounting, valve	2
54◆	17V756	FITTING, adapter, valve	2
55◆	17J564	VALVE, breather	2
56◆	101960	NUT	2
57◆	110460	FITTING, male swivel	4
58◆	598095	TUBE, 5/32 OD nylon, pre-cut to 4.5 in	2

— — — Not sold separately.

● Included in Air Cover Replacement Kit 17H311.

‡ Included in Air Motor Repair Kit 17H304. The kit also includes a bearing installation tool.

▷ Included in Fluid Section Fastener Kit 17H324.

✘ Included in Air Section Fastener Kit 17H326.

◆ Applies to 3D150 models only. Included in Conversion Kit 25D984.

★ Included in Piston Repair Kit 17H308. The kit also includes a bearing installation tool.

▲ Replacement Danger and Warning labels, tags, and cards are available at no cost.

3D350 and 4D350 Models

Ref	Part	Description	Qty
1	17H316 17H317	VALVE, air; medium; includes gasket (13) and screws (17) Smart (for use with DataTrak) Standard	1
2	16X314 16X403 17C116	MANIFOLD, fluid Tri-Clamp npt bspp	2
3	24Y306	DATATRAK KIT; used for models 25M760, 25M761, 25M762, 24W354, 24W355, and 24W356; includes air valve 17H316	1
4	17H409	COVER, fluid	2
5	17H314	BRACKET, mounting, kit; includes ground screw (11) and screws (17)	1
6	24W364 25D844	MANIFOLD, air MANIFOLD, air ◆	1
7●	17H312	AIR COVER KIT	2
8	117237	MUFFLER	1
9	17H307	CARTRIDGES, check valve; 4-pack, includes o-rings (38). <i>See Alternative Check Valve Kit, page 34 for a kit with carbide seats.</i>	1
10✘	— — —	SCREW, hex head, M10–1.5 x 90 mm	6
11	116343	SCREW, ground	1
12●	24A366	VALVE, pilot, 2-pack	1
13‡	— — —	GASKET, air valve, buna-n; also included with air valve (1)	1
14‡	— — —	GASKET, air manifold, buna-n	2
15▷	— — —	SCREW, socket head, M10–1.5 x 30 mm	18
16▷	— — —	SCREW, socket head, M10–1.5 x 16 mm	8
17✘	— — —	SCREW, hex flange, M6–1.0 x 20 mm; also included with air valve (1), mounting bracket (5), and DataTrak (3)	12

Ref	Part	Description	Qty
18	17H303	DIAPHRAGM, overmolded, kit; includes 2 diaphragms, diaphragm replacement tools, and o-rings (38)	1
20★	17H310	PISTON ASSEMBLY, kit	1
21	16X307	PLATE, diaphragm	2
22●	24A915	BUMPER, 2-pack	1
23●‡ ★◆	— — —	BEARING, shaft	4
26● ‡ ★	112181	U-CUP, shaft, 3D pumps U-CUP, shaft, 4D pumps	2 4
27	16X305	CYLINDER, piston	1
28 ‡ ★	16X315	O-RING, piston, buna-n, 6 in. (152 mm) OD	1
29●‡ ★	16X316	O-RING, air covers	2
35▲	188621	LABEL, warning	1
38	17H323	O-RING, manifold, 4-pack; PTFE, also included in check valve cartridge (9) and diaphragm (18)	1
39	17V592 17D584	LABEL, branding, 350cc	2
40	17B546	WASHER	2
52◆	25D846	L-CUP, o-ring seal	2
53◆	17V754	BRACKET, mounting, valve	2
54◆	17V756	FITTING, adapter, valve	2
55◆	17J564	VALVE, breather	2
56◆	101960	NUT	2
57◆	110460	FITTING, male swivel	4
58◆	598095	TUBE, 5/32 OD nylon, pre-cut to 4.5 in	2

— — — Not sold separately.

● Included in Air Cover Replacement Kit 17H312.

‡ Included in Air Motor Repair Kit 17H305. The kit also includes a bearing installation tool.

▷ Included in Fluid Section Fastener Kit 17H325.

✘ Included in Air Section Fastener Kit 17H327.

◆ Applies to 3D350 models only. Included in Conversion Kit 25D985.

★ Included in Piston Repair Kit 17H310. The kit also includes a bearing installation tool.

▲ Replacement Danger and Warning labels, tags, and cards are available at no cost.

Air Valve Parts

Air Valve Disassembly or Reassembly

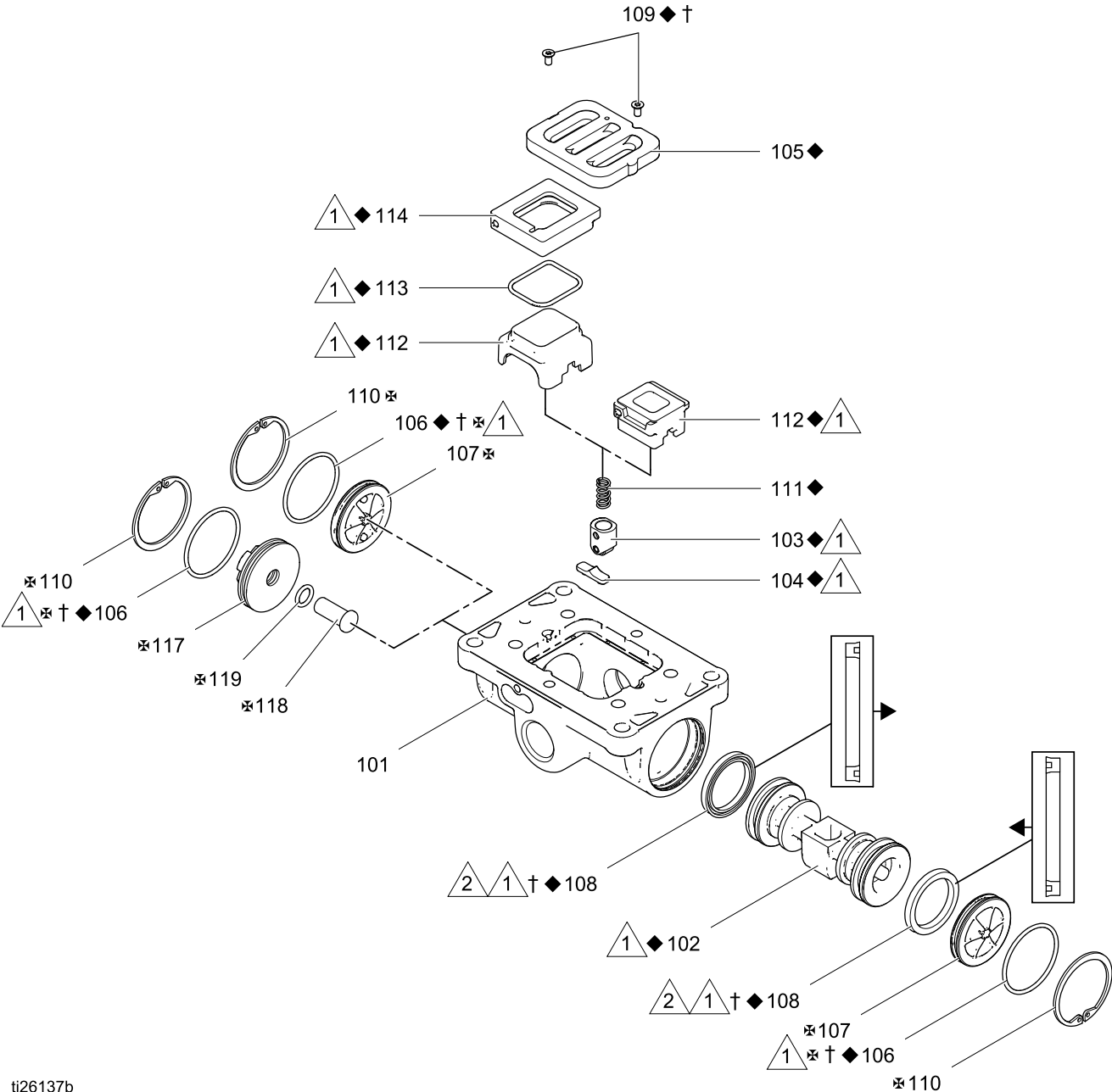

ti26137b

Air Valve Parts

Ref	Description	Qty
101	HOUSING	1
102 ◆	AIR VALVE PISTON	1
103 ◆	DETENT PISTON ASSEMBLY	1
104 ◆	DETENT CAM	1
105 ◆	PLATE, air valve	1
106 ◆†❖	O-RING	2
107 ❖	CAP	
	Standard	2
	Compatible with DataTrak with runaway protection	1
108 ◆†	U-CUP	2
109 ◆†	SCREW	2
110 ◆❖	SNAP RING	2
111 ◆	DETENT SPRING	1
112 ◆	CUP	1
	One-Piece (for 150 cc models)	
	Three-Piece, with refs. 113 and 114 (for 350 cc models)	

Ref	Description	Qty
113 ◆	O-RING (for cup, ref. 112))	1
114 ◆	BASE (for cup, ref. 112)	1
117 ❖	CAP (for DataTrak models with runaway protection)	1
118 ❖	BUTTON (for DataTrak models with runaway protection)	1
119 ◆†❖	O-RING (for DataTrak models with runaway protection)	1
13 ◆†	GASKET, air valve	1

◆ *Included in Air Valve Repair Kit 24A537 (3D150 and 4D150 Models) and 24A538 (3D350 and 4D350 Models)*

† *Included in Air Valve Seal Kit 24A535 (3D150 and 4D150 Models) and 24A536 (3D350 and 4D350 Models)*

❖ *Included in Air Valve End Cap Kit. See Repair Kits, page 33.*

Repair Kits

Kit Description	3D150 and 4D150	3D350 and 4D350
Complete Air Valve Replacement Kit — Standard (No DataTrak)	17H319	17H317
Complete Air Valve Replacement Kit — Compatible with DataTrak with Runaway Protection	17H318	17H316
◆ Air Valve Repair Kit	24A537	24A538
† Air Valve Seal Kit	24A535	24A536
❖ Air Valve End Cap Kit — Standard (No DataTrak) Air Valve	24A360	24A361
❖ Air Valve End Cap Kit — Compatible with DataTrak with Runaway Protection	24A362	24A363
● Air Cover Replacement Kit	25E004 (3D150 only) 17H311 (4D150 only)	25E005 (3D350 only) 17H312 (4D350 only)
‡ Air Motor Repair Kit	17H304 (3D150 only) 17W767 (4D150 only)	17H305 (3D350 only) 17W768 (4D350 only)
▶ Fluid Section Fastener Kit	17H324	17H325
✖ Air Section Fastener Kit	17H326	17H327
★ Piston Repair Kit	17W769 (3D150 only) 17H308 (4D150 only)	17W770 (3D350 only) 17H310 (4D350 only)
Diaphragm Kit*	17H302	17H303
Diaphragm Removal Tool	25E139	25E140
Solenoid Replacement Kit	17H320	17H321

* The Diaphragm Kits contain tools to make it easier to remove the diaphragms. The diaphragm removal tools are also available separately.

Conversion Kits

Kit Description	Convert 4D150 to 3D150 (4:1 to 3:1)	Convert 4D350 to 3D350 (4:1 to 3:1)
Conversion Kit for Endura-Flo™ Diaphragm Pumps	25D984	25D985

Alternative Check Valve Kit

Kit Description	3D150 and 4D150	3D350 and 4D350
Carbide Seat Check Valve Kit — Includes four check valve cartridges with carbide seats and four o-rings (ref. 38)	17N356	17N357

Accessories

Kit Description	3D150 and 4D150	3D350 and 4D350
DataTrak Conversion Kit	24Y304	24Y306
Fluid Pressure Limit Kit*	17J610	17J888
Floor Stand Kit ♦	17H315	
Reed Switch (Cycle Count) Kit	17W772	

* This kit limits the air pressure to 70 psi (4.8 bar) maximum. This limit results in a maximum fluid pressure of 300 psi (20.7 bar) for 4D pumps and 220 psi (15.2 bar) for 3D pumps at the pump outlet.

♦ Floor Stand Kit 17H315 Shown

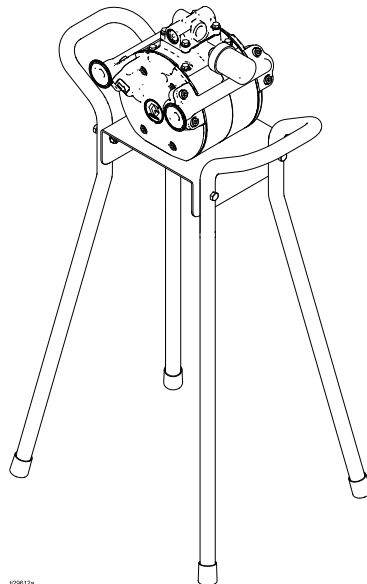

129812a

Performance Charts

3D150 Models

Operating Air Pressure

- A**
100 psi (0.7 MPa, 7.0 bar)
- B**
70 psi (0.48 MPa, 4.8 bar)
- C**
40 psi (0.28 MPa, 2.8 bar)

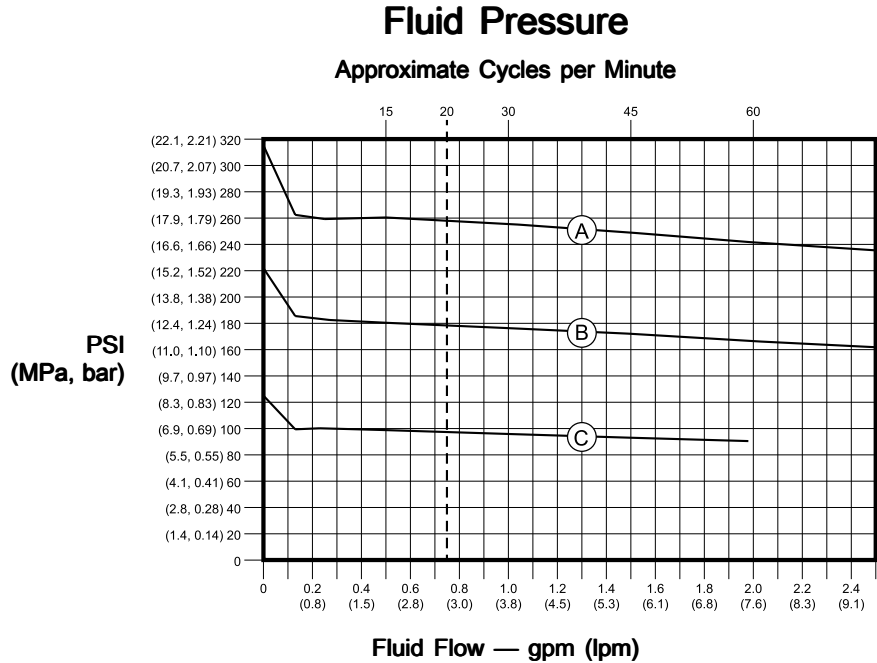

How to Read the Charts

1. Locate the fluid flow rate along the bottom of the chart.
2. Follow the vertical line up to the intersection with the selected operating air pressure curve.
3. Follow left to the scale to read the **fluid outlet pressure** (top chart) or the **air consumption** (bottom chart).

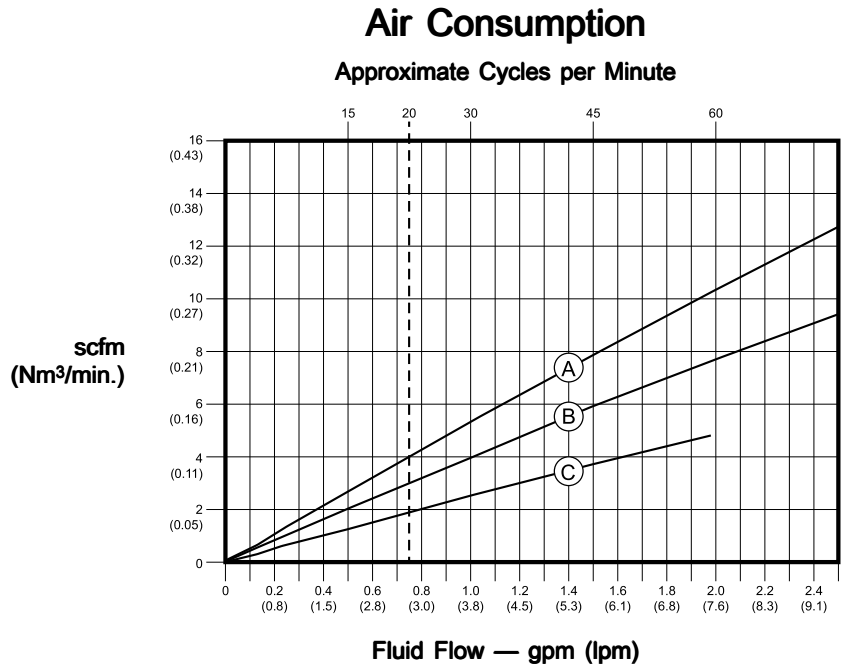

3D350 Models

Operating Air Pressure

- A**
100 psi (0.7 MPa, 7.0 bar)
- B**
70 psi (0.48 MPa, 4.8 bar)
- C**
40 psi (0.28 MPa, 2.8 bar)

Fluid Pressure

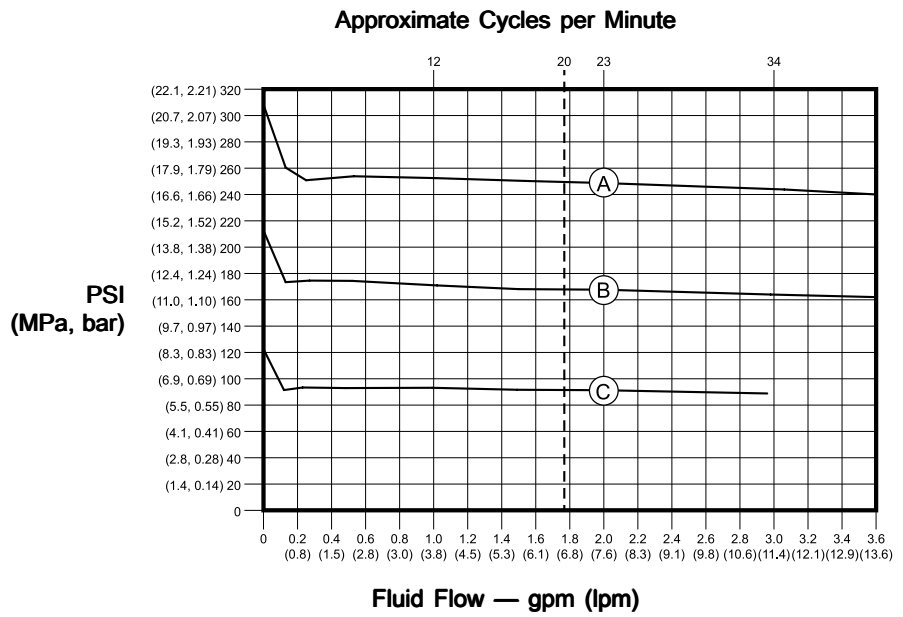

How to Read the Charts

1. Locate the fluid flow rate along the bottom of the chart.
2. Follow the vertical line up to the intersection with the selected operating air pressure curve.
3. Follow left to the scale to read the **fluid outlet pressure** (top chart) or the **air consumption** (bottom chart).

Air Consumption

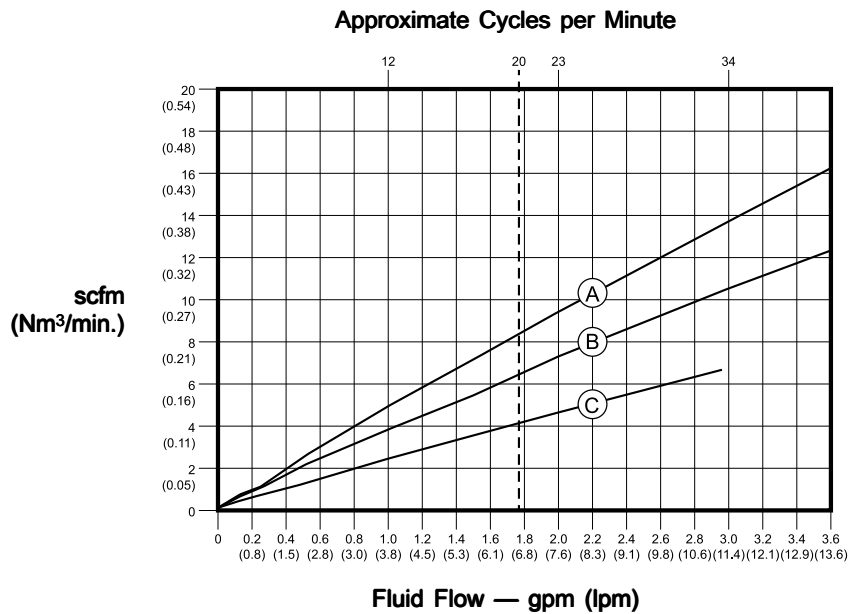

4D150 Models

- Operating Air Pressure**
- A**
100 psi (0.7 MPa, 7.0 bar)
 - B**
70 psi (0.48 MPa, 4.8 bar)
 - C**
40 psi (0.28 MPa, 2.8 bar)

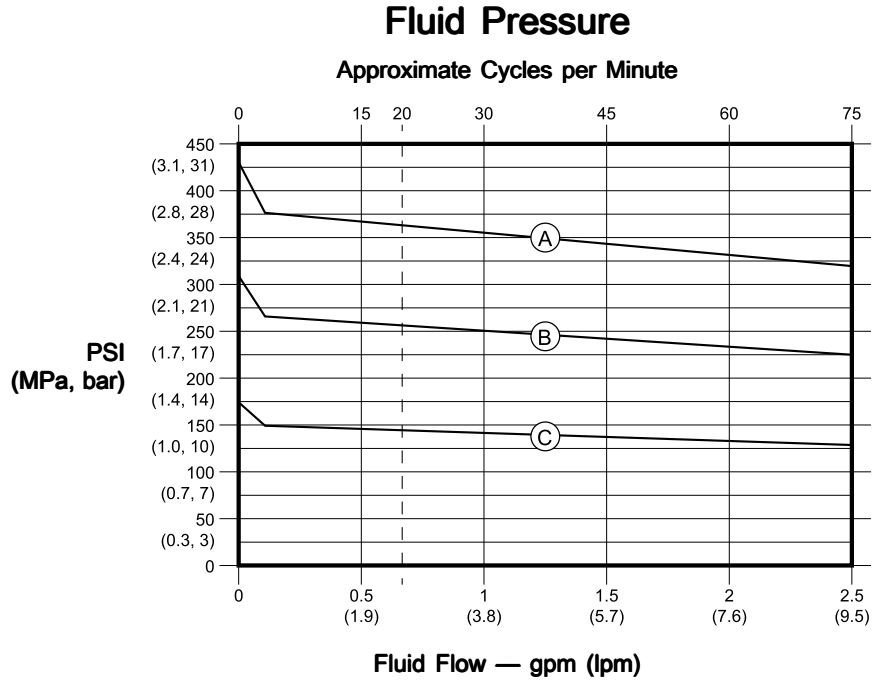

How to Read the Charts

1. Locate the fluid flow rate along the bottom of the chart.
2. Follow the vertical line up to the intersection with the selected operating air pressure curve.
3. Follow left to the scale to read the **fluid outlet pressure** (top chart) or the **air consumption** (bottom chart).

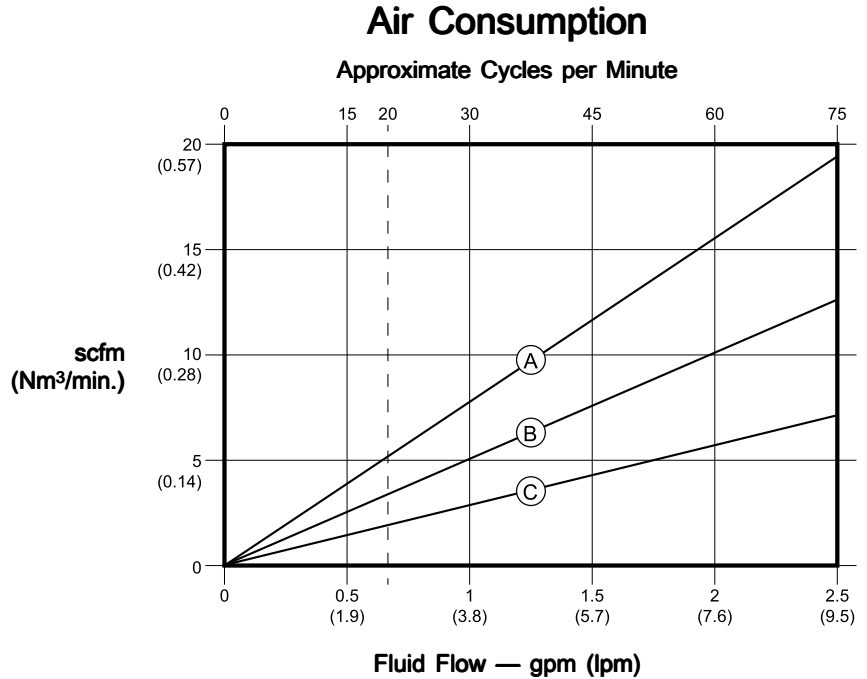

4D350 Models

Operating Air Pressure

- A**
100 psi (0.7 MPa, 7.0 bar)
- B**
70 psi (0.48 MPa, 4.8 bar)
- C**
40 psi (0.28 MPa, 2.8 bar)

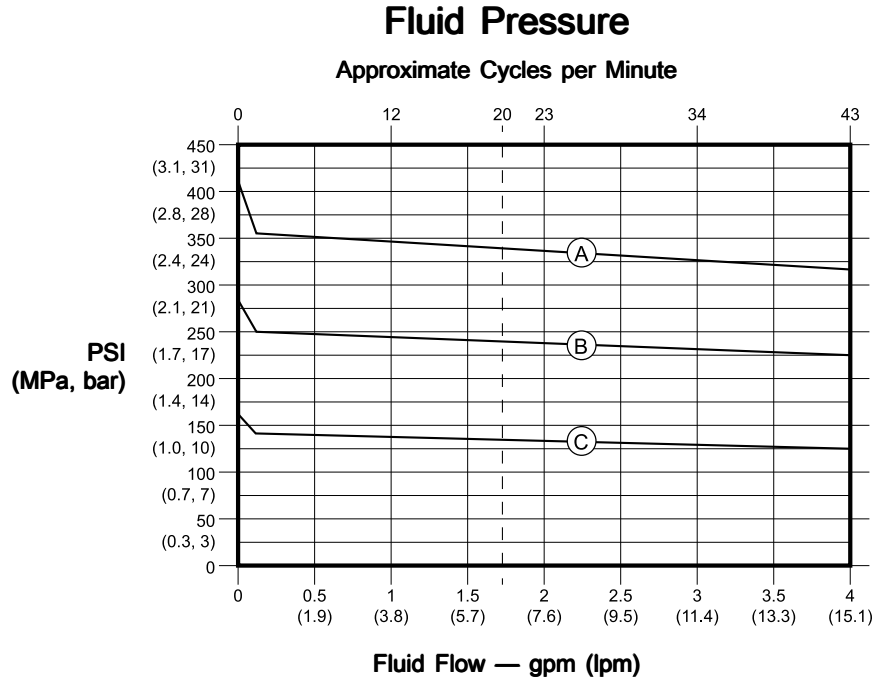

How to Read the Charts

1. Locate the fluid flow rate along the bottom of the chart.
2. Follow the vertical line up to the intersection with the selected operating air pressure curve.
3. Follow left to the scale to read the **fluid outlet pressure** (top chart) or the **air consumption** (bottom chart).

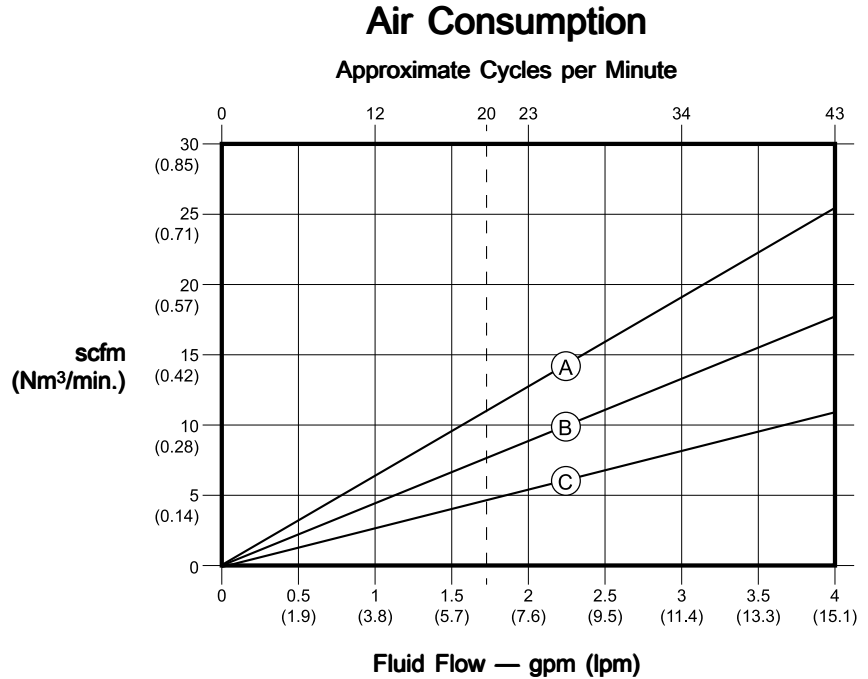

Mounting Dimensions

150cc Model

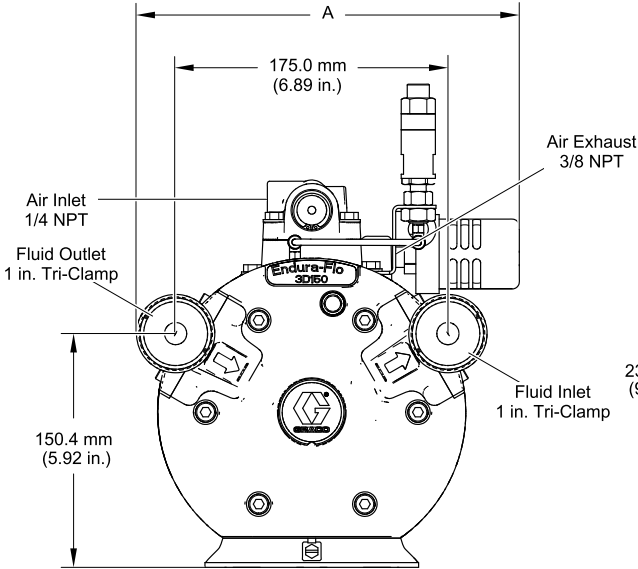

3D150 Model Shown

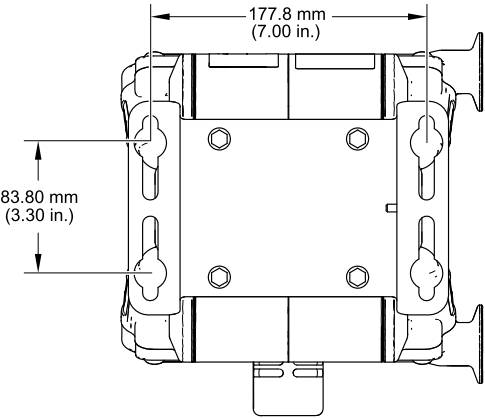
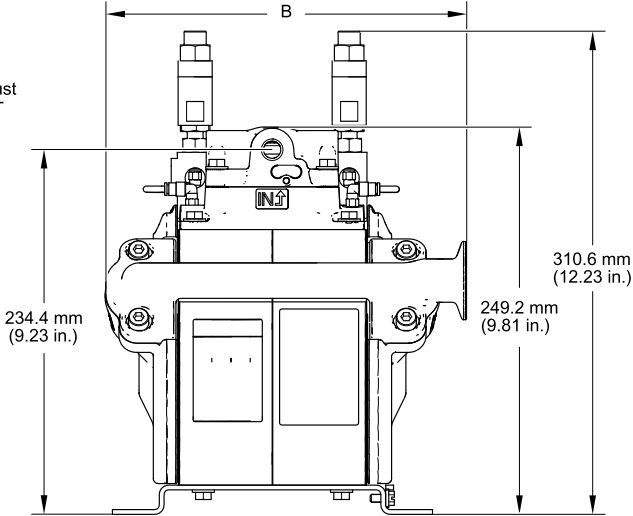

ti22339b

Ref.	Flange Connections	Threaded Pipe Connections
A	246.2 mm (9.69 in.)	235.0 mm (9.25 in.)
B	231.9 mm (9.13 in.)	221.8 mm (8.73 in.)

Mounting Dimensions

350cc Model

3D350 Model Shown

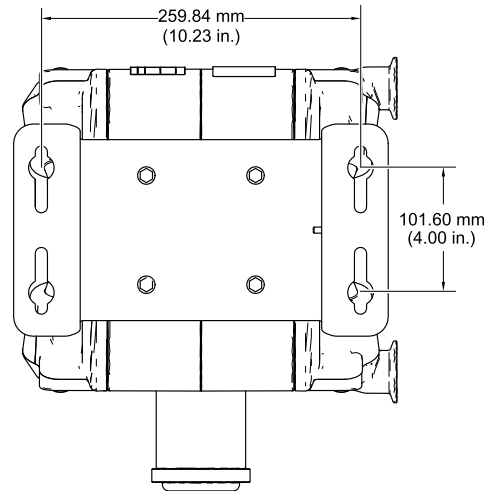
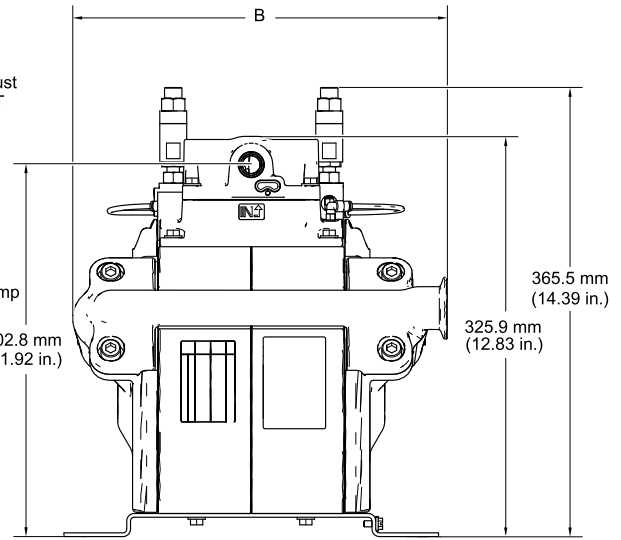
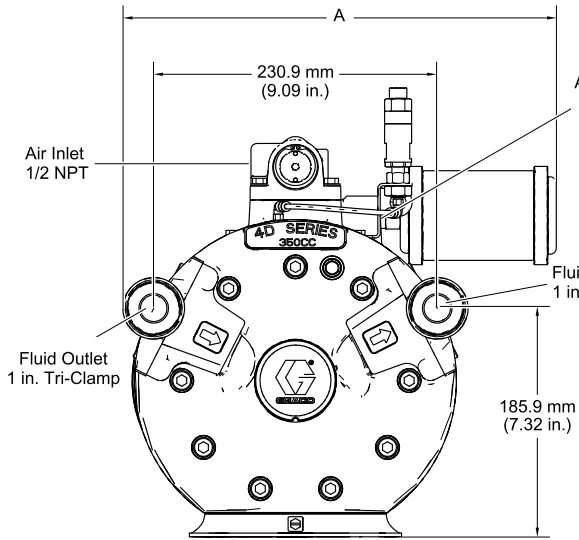

ti23582b

Ref.	Flange Connections	Threaded Pipe Connections
A	353.0 mm (13.9 in.)	345.2 mm (13.59 in.)
B	305.1 mm (12.01 in.)	296.2 mm (11.66 in.)

Technical Specifications

	US	Metric
Maximum air input pressure	100 psi	7 bar, 0.7 MPa
Maximum inlet feed pressure*	70 psi	4.8 bar, 0.48 MPa
<p>* NOTE: If you are pressure feeding the pump inlet, the inlet feed pressurizes the outlet by the corresponding amount. Do not allow the outlet pressure of the Endura-Flo pump to exceed the maximum fluid working pressure.</p> <p>Examples: Pressure feeding the inlet with 60 psi and supplying 80 psi air pressure results in 80psi*4:1+60psi = 380psi fluid pressure for 4D pumps. Pressure feeding the inlet with 60 psi and supplying 80 psi air pressure results in 80psi*3:1+60psi = 300psi fluid pressure for 3D pumps.</p>		
Maximum fluid working pressure		
Models 3D150, 3D350	300 psi	21 bar, 2.1 MPa
Models 4D150, 4D350	400 psi	28 bar, 2.8 MPa
Maximum static fluid pressure		
Models 3D150, 3D350	330 psi	23 bar, 2.3 MPa
Models 4D150, 4D350	430 psi	30 bar, 3.0 MPa
Ratio	3:1 (3D150, 3D350); 4:1 (4D150, 4D350)	
Maximum recommended continuous cycle rate	20 cycles per minute	
Volume per cycle (double stroke)		
Models 3D150, 4D150	5 oz per cycle	150 cc per cycle
Models 3D350, 4D350	12 oz per cycle	350 cc per cycle
Ambient and operating temperature range. Use dry compressed air when operating at low temperatures.	32 to 122°F	0 to 50°C
Compressed air minimum dewpoint temperature	-4 F	-20 C
Dry suction lift	23 ft	7.0 m
Wet suction lift	29 ft	8.8 m
Maximum recommended wet suction lift for continuous pump operation	10 ft (5 psi vacuum pressure)	3.0 m (0.3 Bar vacuum pressure)
Air inlet size		
Models 3D150, 4D150	1/4 npt	
Models 3D350, 4D350	1/2 npt	
Fluid inlet size		
Models 3D150, 4D150	1 in. Tri-Clamp Flange, 1/2 in npt, or 1/2 in bspp	
Models 3D350, 4D350	1 in. Tri-Clamp Flange, 3/4 in npt, or 3/4 in bspp	

Technical Specifications

US		Metric
Fluid outlet size		
Models 3D150, 4D150	1 in. Tri-Clamp Flange, 1/2 in npt, or 1/2 in. bspp	
Models 3D350, 4D350	1 in. Tri-Clamp Flange, 3/4 in npt, or 3/4 in. bspp	
Weight (approximate)		
Models 3D150, 4D150	31 lb	14 kg
Models 3D350, 4D350	72 lb	33 kg
Wetted parts		stainless steel, perfluoroelastomer (FFKM), PTFE, Polyphenylene Sulfide (PPS)

Noise Data		
Average Sound Pressure Levels in dBA at 20 cpm (measured at 1 meter (3.28 ft) horizontal, 1.5 meter (4.9 ft) above the equipment)		
At 70 psi (0.5 MPa, 5.0 bar)		
Models 3D150, 4D150	62.3 dBA	
Models 3D350, 4D350	65.1 dBA	
At 100 psi (0.7 MPa, 7.0 bar)		
Models 3D150, 4D150	62.9 dBA	
Models 3D350, 4D350	66.0 dBA	
Sound Power measured per ISO 9614-2		
At 70 psi (0.5 MPa, 5.0 bar)		
Models 3D150, 4D150	70.8 dBA	
Models 3D350, 4D350	74.1 dBA	
At 100 psi (0.7 MPa, 7.0 bar)		
Models 3D150, 4D150	71.6 dBA	
Models 3D350, 4D350	75.7 dBA	

Graco Standard Warranty

Graco warrants all equipment referenced in this document which is manufactured by Graco and bearing its name to be free from defects in material and workmanship on the date of sale to the original purchaser for use. With the exception of any special, extended, or limited warranty published by Graco, Graco will, for a period of twelve months from the date of sale, repair or replace any part of the equipment determined by Graco to be defective. This warranty applies only when the equipment is installed, operated and maintained in accordance with Graco's written recommendations.

This warranty does not cover, and Graco shall not be liable for general wear and tear, or any malfunction, damage or wear caused by faulty installation, misapplication, abrasion, corrosion, inadequate or improper maintenance, negligence, accident, tampering, or substitution of non-Graco component parts. Nor shall Graco be liable for malfunction, damage or wear caused by the incompatibility of Graco equipment with structures, accessories, equipment or materials not supplied by Graco, or the improper design, manufacture, installation, operation or maintenance of structures, accessories, equipment or materials not supplied by Graco.

This warranty is conditioned upon the prepaid return of the equipment claimed to be defective to an authorized Graco distributor for verification of the claimed defect. If the claimed defect is verified, Graco will repair or replace free of charge any defective parts. The equipment will be returned to the original purchaser transportation prepaid. If inspection of the equipment does not disclose any defect in material or workmanship, repairs will be made at a reasonable charge, which charges may include the costs of parts, labor, and transportation.

THIS WARRANTY IS EXCLUSIVE, AND IS IN LIEU OF ANY OTHER WARRANTIES, EXPRESS OR IMPLIED, INCLUDING BUT NOT LIMITED TO WARRANTY OF MERCHANTABILITY OR WARRANTY OF FITNESS FOR A PARTICULAR PURPOSE.

Graco's sole obligation and buyer's sole remedy for any breach of warranty shall be as set forth above. The buyer agrees that no other remedy (including, but not limited to, incidental or consequential damages for lost profits, lost sales, injury to person or property, or any other incidental or consequential loss) shall be available. Any action for breach of warranty must be brought within two (2) years of the date of sale.

GRACO MAKES NO WARRANTY, AND DISCLAIMS ALL IMPLIED WARRANTIES OF MERCHANTABILITY AND FITNESS FOR A PARTICULAR PURPOSE, IN CONNECTION WITH ACCESSORIES, EQUIPMENT, MATERIALS OR COMPONENTS SOLD BUT NOT MANUFACTURED BY GRACO. These items sold, but not manufactured by Graco (such as electric motors, switches, hose, etc.), are subject to the warranty, if any, of their manufacturer. Graco will provide purchaser with reasonable assistance in making any claim for breach of these warranties.

In no event will Graco be liable for indirect, incidental, special or consequential damages resulting from Graco supplying equipment hereunder, or the furnishing, performance, or use of any products or other goods sold hereto, whether due to a breach of contract, breach of warranty, the negligence of Graco, or otherwise.

FOR GRACO CANADA CUSTOMERS

The Parties acknowledge that they have required that the present document, as well as all documents, notices and legal proceedings entered into, given or instituted pursuant hereto or relating directly or indirectly hereto, be drawn up in English. Les parties reconnaissent avoir convenu que la rédaction du présente document sera en Anglais, ainsi que tous documents, avis et procédures judiciaires exécutés, donnés ou intentés, à la suite de ou en rapport, directement ou indirectement, avec les procédures concernées.

Graco Information

For the latest information about Graco products, visit www.graco.com.
For patent information, see www.graco.com/patents.

To place an order, contact your Graco Distributor or call to identify the nearest distributor.

Phone: 612-623-6921 **or Toll Free:** 1-800-328-0211 **Fax:** 612-378-3505

All written and visual data contained in this document reflects the latest product information available at the time of publication. Graco reserves the right to make changes at any time without notice.

Original Instructions. This manual contains English. MM 333015

Graco Headquarters: Minneapolis
International Offices: Belgium, China, Japan, Korea

GRACO INC. AND SUBSIDIARIES • P.O. BOX 1441 • MINNEAPOLIS MN 55440-1441 • USA
Copyright 2015, Graco Inc. All Graco manufacturing locations are registered to ISO 9001.

www.graco.com
Revision J, September 2018