This manual contains important warnings and information.
READ AND KEEP FOR REFERENCE.
INSTRUCTIONS

First choice when quality counts.™

24-Gallon (90-Liter)

Oil Ace™ Pressurized Oil Drain

Model 115599, Series A

Table of Contents

Warnings	2
Assembly and Operation	4
Parts Drawing	6
Parts List	7
Technical Data	7
Graco Phone Number	8

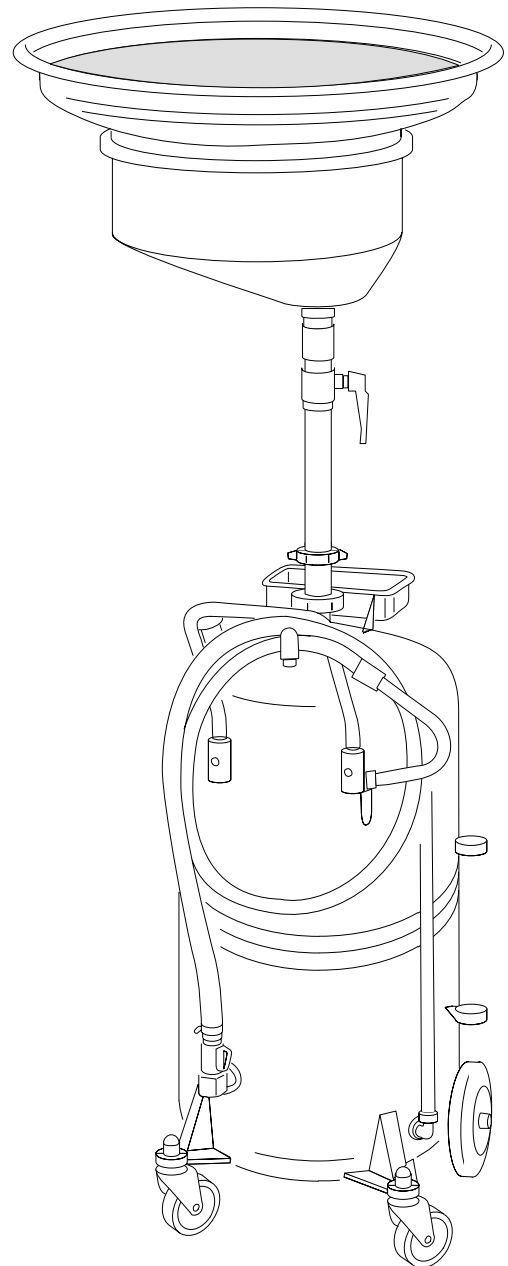

9426A

Symbols

Warning Symbol



This symbol alerts you to the possibility of serious injury or death if you do not follow the instructions.

Caution Symbol



This symbol alerts you to the possibility of damage to or destruction of equipment if you do not follow the instructions.

WARNING



INSTRUCTIONS

EQUIPMENT MISUSE HAZARD

Equipment misuse can cause the equipment to malfunction and result in serious injury.

- This equipment is for professional use only.
- Read all instruction manuals before you operate this equipment.
- Use the equipment only for its intended purpose. If you are not sure, contact your Graco distributor.
- Do not alter or modify this equipment.
- Check equipment daily. Repair or replace worn or damaged parts immediately.
- This equipment is intended for collection of petroleum lubricants or antifreeze only. Any other use or collection of any other fluids could result in damage to the equipment or serious bodily injury.
- Always wear protective eyewear, gloves, clothing, and respirator as recommended by the fluid and solvent manufacturer.
- Comply with all applicable local, state, and national fire, electrical, and safety regulations.
- Dispose of waste fluids according to all local, state, and national guidelines.



FIRE AND EXPLOSION HAZARD

Poor ventilation, open flames, or sparks can cause a hazardous condition and result in a fire or explosion and serious injury.

- Do not exceed 8 psi (0.5 bar, 50 kPa) air supply pressure.
- Do not tamper with air relief valve setting.
- If you are using this unit with an evacuation system, make sure the pumping system is installed and grounded according to the manufacturer's recommendation.
- Provide fresh air ventilation to avoid the buildup of flammable fumes.
- Extinguish all open flames in the work area.
- Do not smoke in the work area.

WARNING

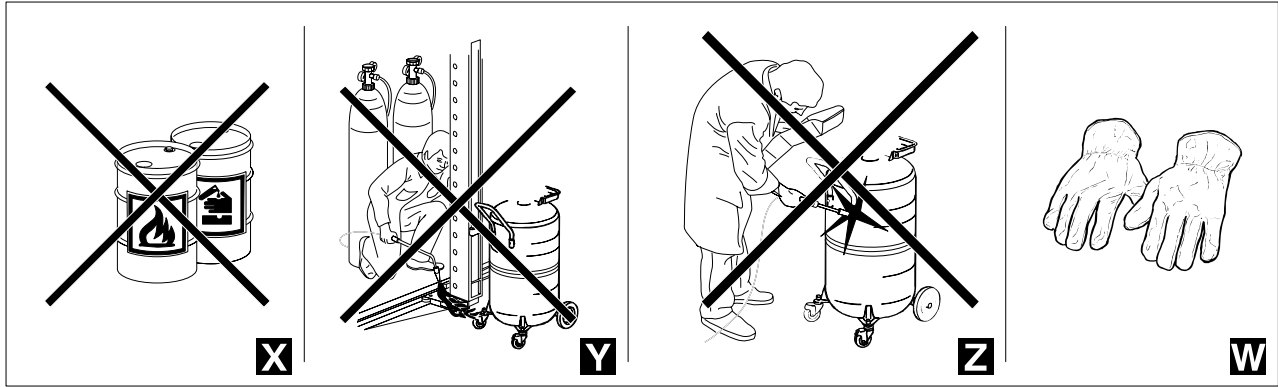

- X** – Do not drain caustic or flammable products.
- Y** – Do not expose the tank to any source of heat.
- Z** – Do not do any welding on the tank.
- W** – While draining high temperature oils, keep hands and face protected.

United States Government safety standards have been adopted under the Occupational Safety and Health Act. You should consult these standards—particularly the General Standards, Part 1910.

Assembly and Operation

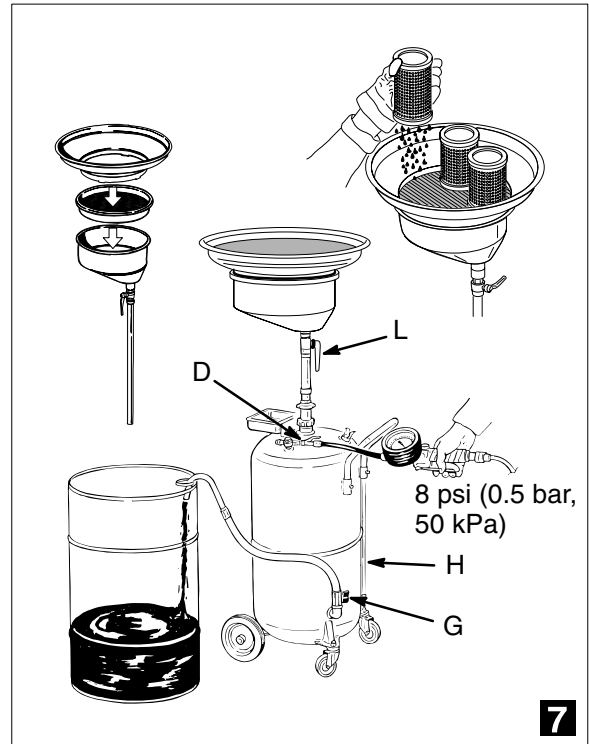
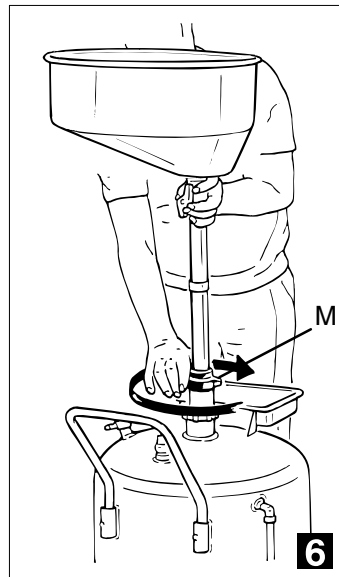
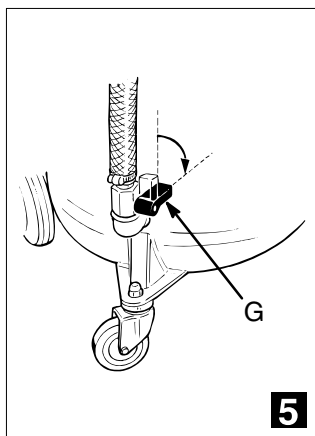
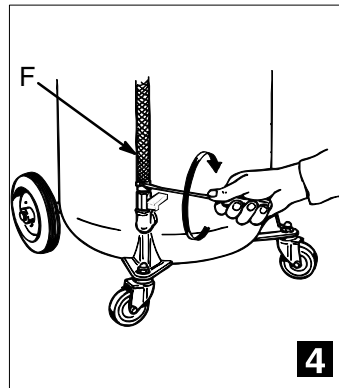
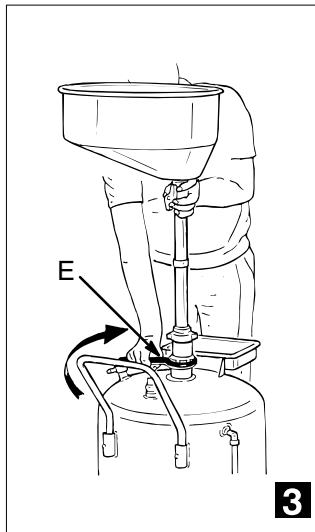
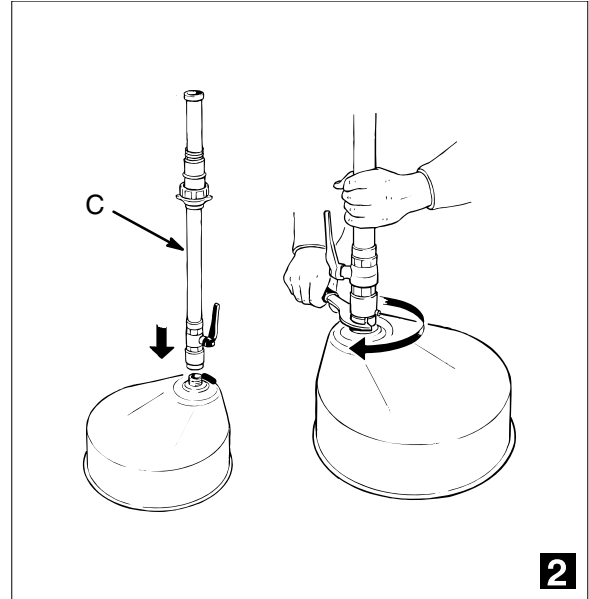
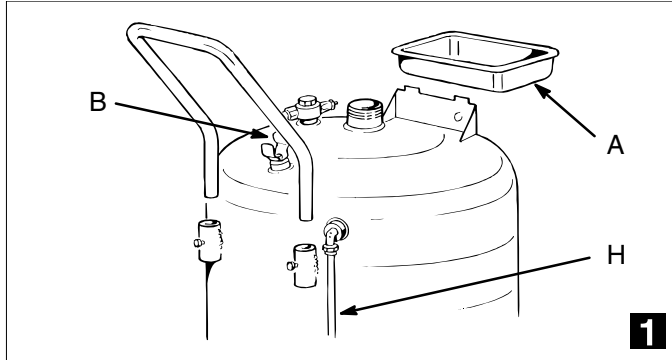

Assembly and Operation

ASSEMBLY

1. Fig. 1. Insert handle into holding fixtures provided on tank and secure it with screws. Place tool tray A on bracket provided. Attach hose retainer B.
2. Fig. 2. Attach drain column C to drain basin and tighten it with suitable wrench.
3. Fig. 3. Connect drain assembly to tank by tightening ring nut E with suitable wrench.
4. Fig. 4. Attach hose F with hose clamp provided.
5. Fig. 5. Close red handled ball valve G by turning it clockwise.

OPERATING DRAIN

CAUTION

- Fig. 6. When draining fluids into the catch basin, avoid automatic closing of the bleeder vent on the funnel by leaving 1.5 to 2 in. (4–5 cm.) clearance from upper limit funnel extension.
- Fig. 7. The oil level gauge H located on the side of the tank indicates the quantity of oil drained. Never fill the tank over the maximum level indicated by the gauge

1. Fig. 6. To raise and lower funnel, loosen ring nut M and hand tighten after reaching desired height.

EMPTYING DRAIN

CAUTION

Before emptying the tank, lift the funnel to its upper limit so that the safety air bleeder vent is automatically closed.

1. Fig. 7. Close red handled ball valve L.
2. Attach end of drain hose to suitable waste oil container.
3. Connect 8 psi (0.5 bar, 50 kPa) shop air to valve D and open ball valve G.
4. After fluids have been transferred from unit's tank close ball valve G.

Note: Unit is equipped with pneumatic safety relief valve that has been factory calibrated at 14 psi (1 bar, 100 kPa).

Parts Drawing

Oil Ace Pressurized Oil Drain, Model 115599, Series A

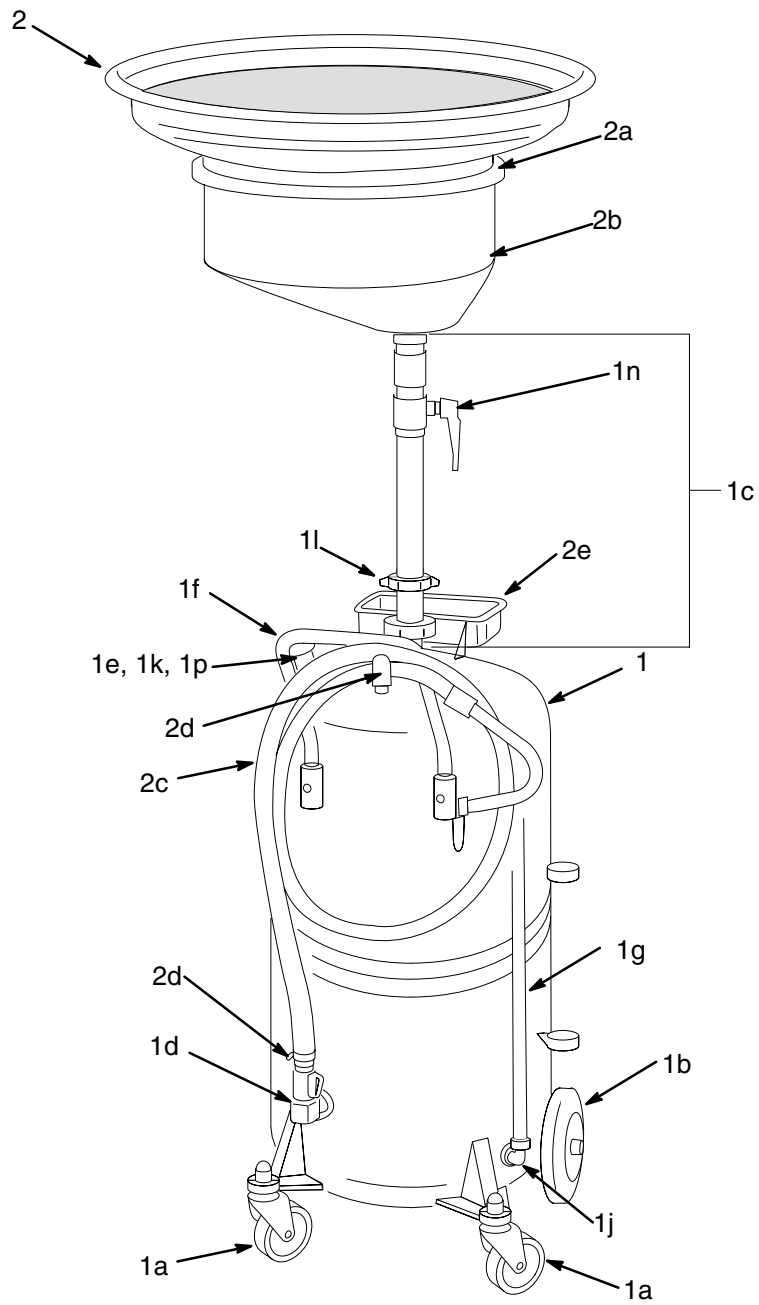

9426A

Parts List

Oil Ace Pressurized Oil Drain, Model 115599, Series A

Ref. No.	Part No.	Description	Qty.
1	242029	Tank Assembly, oil receiver	1
1a	242030	Wheel, swivel	1
1b	242031	Wheel, fixed	1
1c	242033	Upper Valve Assembly (includes 1l and 1n)	1
1d	242036	Valve, dispense	1
1e	242034	Air Valve Assembly (includes 1k and 1p)	1
1f	115572	Handle	1
1g	242038	Tube, gauge	1
1h	242040	Kit, O-ring <i>not shown</i>	1
1j	242041	Fitting, union	1
1k	242042	Valve, intake	1
1l	115574	Nut, ring	1
1n	115576	Valve, ball	1
1p	115577	Valve, relief	1
2	242064	Funnel Assembly, oil receiver	1
2a	242039	Funnel	1
2b	242032	Bowl	1
2c	242035	Hose, discharge	1
2d	242037	Kit, screws/clip/hose clamp	1
2e	115573	Tray	1

Technical Data

Length	21 in. (533 mm)
Width	16 in. (406 mm)
Height	
with bowl at lowest adjustment	55 in. (1397 mm)
with bowl at highest adjustment	75 in. (1905 mm)
Funnel Diameter	23 in. (584 mm)
Dry Weight	74 lb (33.6 kg)
Wetted parts	linear low-density polyethylene (LLDPE), zinc-plated steel, brass, nylon, polypropylene, PVC
Recommended operating temperature	30° to 105° F (−1° to 41° C)

Graco Standard Warranty

Graco warrants all equipment manufactured by Graco and bearing its name to be free from defects in material and workmanship on the date of sale by an authorized Graco distributor to the original purchaser for use. With the exception of any special, extended, or limited warranty published by Graco, Graco will, for a period of twelve months from the date of sale, repair or replace any part of the equipment determined by Graco to be defective. This warranty applies only when the equipment is installed, operated and maintained in accordance with Graco's written recommendations.

This warranty does not cover, and Graco shall not be liable for general wear and tear, or any malfunction, damage or wear caused by faulty installation, misapplication, abrasion, corrosion, inadequate or improper maintenance, negligence, accident, tampering, or substitution of non-Graco component parts. Nor shall Graco be liable for malfunction, damage or wear caused by the incompatibility of Graco equipment with structures, accessories, equipment or materials not supplied by Graco, or the improper design, manufacture, installation, operation or maintenance of structures, accessories, equipment or materials not supplied by Graco.

This warranty is conditioned upon the prepaid return of the equipment claimed to be defective to an authorized Graco distributor for verification of the claimed defect. If the claimed defect is verified, Graco will repair or replace free of charge any defective parts. The equipment will be returned to the original purchaser transportation prepaid. If inspection of the equipment does not disclose any defect in material or workmanship, repairs will be made at a reasonable charge, which charges may include the costs of parts, labor, and transportation.

THIS WARRANTY IS EXCLUSIVE, AND IS IN LIEU OF ANY OTHER WARRANTIES, EXPRESS OR IMPLIED, INCLUDING BUT NOT LIMITED TO WARRANTY OF MERCHANTABILITY OR WARRANTY OF FITNESS FOR A PARTICULAR PURPOSE.

Graco's sole obligation and buyer's sole remedy for any breach of warranty shall be as set forth above. The buyer agrees that no other remedy (including, but not limited to, incidental or consequential damages for lost profits, lost sales, injury to person or property, or any other incidental or consequential loss) shall be available. Any action for breach of warranty must be brought within two (2) years of the date of sale.

Graco makes no warranty, and disclaims all implied warranties of merchantability and fitness for a particular purpose in connection with accessories, equipment, materials or components sold but not manufactured by Graco. These items sold, but not manufactured by Graco (such as electric motors, switches, hose, etc.), are subject to the warranty, if any, of their manufacturer. Graco will provide purchaser with reasonable assistance in making any claim for breach of these warranties.

In no event will Graco be liable for indirect, incidental, special or consequential damages resulting from Graco supplying equipment hereunder, or the furnishing, performance, or use of any products or other goods sold hereto, whether due to a breach of contract, breach of warranty, the negligence of Graco, or otherwise.

FOR GRACO CANADA CUSTOMERS

The parties acknowledge that they have required that the present document, as well as all documents, notices and legal proceedings entered into, given or instituted pursuant hereto or relating directly or indirectly hereto, be drawn up in English. Les parties reconnaissent avoir convenu que la rédaction du présente document sera en Anglais, ainsi que tous documents, avis et procédures judiciaires exécutés, donnés ou intentés à la suite de ou en rapport, directement ou indirectement, avec les procédures concernées.

Graco Phone Number

TO PLACE AN ORDER, contact your Graco distributor, or call this number to identify the distributor closest to you:

1-800-533-9655 Toll Free

612-623-6928

612-378-3590 Fax

*All written and visual data contained in this document reflects the latest product information available at the time of publication.
Graco reserves the right to make changes at any time without notice.*

Sales Offices: Minneapolis, Detroit

International Offices: Belgium, Korea, Hong Kong, Japan

GRACO INC. P.O. BOX 1441 MINNEAPOLIS, MN 55440-1441

www.graco.com

PRINTED IN USA 309042 October 1999, Revised December 2000