

Fluid Automation F4 Series

3A3103J

EN

Kits and accessories for use with Fluid Automation F4 series systems.
For professional use only.

Not approved for use in explosive atmospheres or hazardous locations.

For use with models:

F4-5

F4-55

F4-55-5

Refer to the Fluid Automation F4 Series Setup-Operation manual 335028 for maximum working pressure and model information.



Important Safety Instructions

Read all warnings and instructions in this manual and the Fluid Automation F4 Series Setup-Operation manual 335028. Save all instructions.

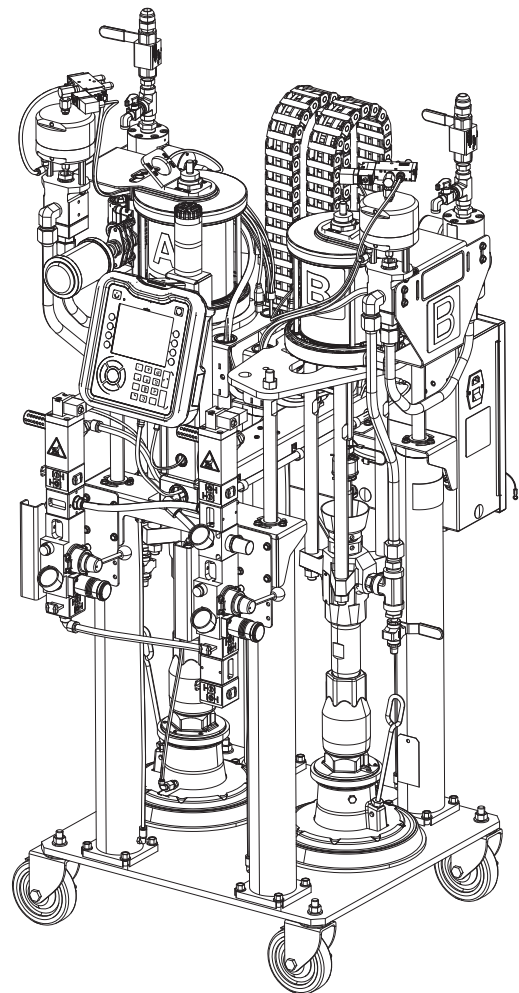

Related Manuals









Refer to Fluid Automation F4 Series Setup-Operation manual 335028 for the complete list of related manuals.

Contents





Related Manuals	2	Tapered Thread Mixing Stack, 24R681	56
Warnings	3	Tapered Thread Mixing Stack, 25A169	59
Installation	6	Tapered Thread Mixing Stack, SK556 and SK556-2A	61
Pressure Relief Procedure	6	Manifold Assembly, SA914-3A/-5A	63
F4-55 Caster Kit, 24X218	7	Material In-line Filter, SA925-1A	66
Dual Press Kit, 25A102	7	Material In-line Filter, SA926-1A	67
Second Press Cable Kit, 25A106	9	Material Regulators, SA920-G and SA921-G ..	68
Mixing Stacks Supported	10	Color Injector Kit, 25A108	69
Material In-line Filters	16	Color Injector Assembly, SN751-1A	70
Material Regulators	18	Colorant Tank Kit, 25A104	72
Colorant Tank Kits	20	Colorant Tank Kit, 25A105	74
Color Flow Meter Kits	22	Color Flow Meter Kits, 25A103 and 25A161 ..	76
Color Injector Kits	22	Continuous Level Sensor Kit, 25A100	77
Continuous Level Sensor Kits	24	Continuous Level Sensor Kit, 25A101	78
5-Gallon Pail Girdle, 25A160	26	5-Gallon Pail Girdle, 25A160	79
Pressure Transducer Kit, 25C237	27	Pressure Transducer Kit, 25C237	80
Parts	29	Technical Data	81
F4-55 Caster Kit, 24X218	29	Graco Standard Warranty	82
Dual Press Kit, 25A102	30		
Second Press Cable Kit, 25A106	31		
Straight Thread Multi-pass Mixing Stack, 25A990-993	32		
Straight Thread Single-pass Mixing Stack, 25A995-998	34		
Multi-pass Stack Mixer, 25A876	36		
Single-pass Stack Mixer, 25C003	37		
In-line Filter Replacement Kits	38		
Manifold Assembly, 25B014	39		
Shut-off Valve, 25A987	43		
Two-pass Mixer Assembly, 25B016	44		
Material In-line Filter, 25A983	45		
Material Regulator, 25A892 and 25A899	46		
Color Injector, 25C478	48		
Mini Single-pass Mixing Stack, 25C794/99	50		
Mixer-Material Regulator Component, 25C792/93 52	52		
Stack Bracket Kit, 25C998	54		
Stack Adapter Kit, 25D011	55		

Warnings

The following warnings are for the setup, use, grounding, maintenance, and repair of Fluid Automation F4 Series equipment. The exclamation point symbol alerts you to a general warning and the hazard symbols refer to procedure-specific risks. When these symbols appear in the body of this manual or on warning labels, refer back to these Warnings. Product-specific hazard symbols and warnings not covered in this section may appear throughout the body of this manual where applicable.

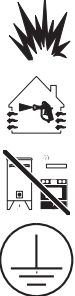
 WARNING	
 	<p>ELECTRIC SHOCK HAZARD</p> <p>This equipment must be grounded. Improper grounding, setup, or usage of the system can cause electric shock.</p> <ul style="list-style-type: none"> • Turn off and disconnect power cord before servicing equipment. • Connect only to grounded electrical outlets. • Use only 3-wire extension cords. • Ensure ground prongs are intact on power and extension cords. • Do not expose to rain. Store indoors
  	<p>SKIN INJECTION HAZARD</p> <p>High-pressure fluid from dispensing device, hose leaks, or ruptured components will pierce skin. This may look like just a cut, but it is a serious injury that can result in amputation. Get immediate surgical treatment.</p> <ul style="list-style-type: none"> • Do not point dispensing device at anyone or at any part of the body. • Do not put your hand over the fluid outlet. • Do not stop or deflect leaks with your hand, body, glove, or rag. • Follow the Pressure Relief Procedure when you stop dispensing and before cleaning, checking, or servicing equipment. • Tighten all fluid connections before operating the equipment. • Check hoses and couplings daily. Replace worn or damaged parts immediately.
 	<p>MOVING PARTS HAZARD</p> <p>Moving parts can pinch, cut or amputate fingers and other body parts.</p> <ul style="list-style-type: none"> • Keep clear of moving parts. • Do not operate equipment with protective guards or covers removed. • Pressurized equipment can start without warning. Before checking, moving, or servicing equipment, follow the Pressure Relief Procedure and disconnect all power sources.

! WARNING

	<p>FIRE AND EXPLOSION HAZARD</p> <p>Flammable fumes, such as solvent and paint fumes, in work area can ignite or explode. Paint or solvent flowing through the equipment can cause static sparking. To help prevent fire and explosion:</p> <ul style="list-style-type: none"> • Use equipment only in well ventilated area. • Eliminate all ignition sources; such as pilot lights, cigarettes, portable electric lamps, and plastic drop cloths (potential static arc). • Ground all equipment in the work area. See Grounding instructions. • Never spray or flush solvent at high pressure. • Keep work area free of debris, including solvent, rags, and gasoline. • Do not plug or unplug power cords, or turn power or light switches on or off when flammable fumes are present. • Use only grounded hoses. • Hold gun firmly to side of grounded pail when triggering into pail. Do not use pail liners unless they are anti-static or conductive. • Stop operation immediately if static sparking occurs or you feel a shock. Do not use equipment until you identify and correct the problem. • Keep a working fire extinguisher in the work area.
	<p>EQUIPMENT MISUSE HAZARD</p> <p>Misuse can cause death or serious injury.</p> <ul style="list-style-type: none"> • Do not operate the unit when fatigued or under the influence of drugs or alcohol. • Do not exceed the maximum working pressure or temperature rating of the lowest rated system component. See Technical Data in all equipment manuals. • Use fluids and solvents that are compatible with equipment wetted parts. See Technical Data in all equipment manuals. Read fluid and solvent manufacturer's warnings. For complete information about your material, request MSDS from distributor or retailer. • Do not leave the work area while equipment is energized or under pressure. • Turn off all equipment and follow the Pressure Relief Procedure when equipment is not in use. • Check equipment daily. Repair or replace worn or damaged parts immediately with genuine manufacturer's replacement parts only. • Do not alter or modify equipment. Alterations or modifications may void agency approvals and create safety hazards. • Make sure all equipment is rated and approved for the environment in which you are using it. • Use equipment only for its intended purpose. Call your distributor for information. • Route hoses and cables away from traffic areas, sharp edges, moving parts, and hot surfaces. • Do not kink or over bend hoses or use hoses to pull equipment. • Keep children and animals away from work area. • Comply with all applicable safety regulations.
	<p>TOXIC FLUID OR FUMES HAZARD</p> <p>Toxic fluids or fumes can cause serious injury or death if splashed in the eyes or on skin, inhaled, or swallowed.</p> <ul style="list-style-type: none"> • Read SDSs to know the specific hazards of the fluids you are using. • Store hazardous fluid in approved containers, and dispose of it according to applicable guidelines.
	<p>PERSONAL PROTECTIVE EQUIPMENT</p> <p>Wear appropriate protective equipment when in the work area to help prevent serious injury, including eye injury, hearing loss, inhalation of toxic fumes, and burns. Protective equipment includes but is not limited to:</p> <ul style="list-style-type: none"> • Protective eyewear, and hearing protection. • Respirators, protective clothing, and gloves as recommended by the fluid and solvent manufacturer

! WARNING



PRESSURIZED ALUMINUM PARTS HAZARD

Use of fluids that are incompatible with aluminum in pressurized equipment can cause serious chemical reaction and equipment rupture. Failure to follow this warning can result in death, serious injury, or property damage.

- Do not use 1,1,1-trichloroethane, methylene chloride, other halogenated hydrocarbon solvents or fluids containing such solvents.
- Do not use chlorine bleach.
- Many other fluids may contain chemicals that can react with aluminum. Contact your material supplier for compatibility.



BURN HAZARD

Equipment surfaces and fluid that's heated can become very hot during operation. To avoid severe burns:

- Do not touch hot fluid or equipment.

Installation

NOTICE

To prevent thread damage, apply POLY-TEMP[®] ceramic tape or equivalent to all National Pipe Threads (NPTs) when installing.

NOTE: Some installation steps reference numbers in parentheses that refer to call outs in parts drawings. See the **Parts** section in this manual for part identification.

Pressure Relief Procedure



Follow the **Pressure Relief Procedure** whenever you see this symbol.

<p>The F4 Series equipment stays pressurized until pressure is manually relieved. To help prevent serious injury from pressurized fluid, such as skin injection, splashing fluid and moving parts, follow the Pressure Relief Procedure before cleaning, checking, or servicing the equipment.</p>					

NOTE: Always place an empty container under the prime valves and the ratio check valves before using them to keep material from dispensing onto the machine.

NOTE: There is pressure on each side of both the A and B dosing valves. Pressure must be relieved on the pump side and the stack side of the dosing valves.

1. To relieve pressure at the pump, turn off the system air slider valve.

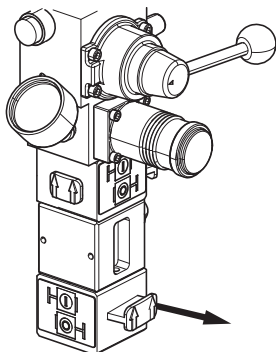

2. Open the prime ball valves for both the A and B pumps.

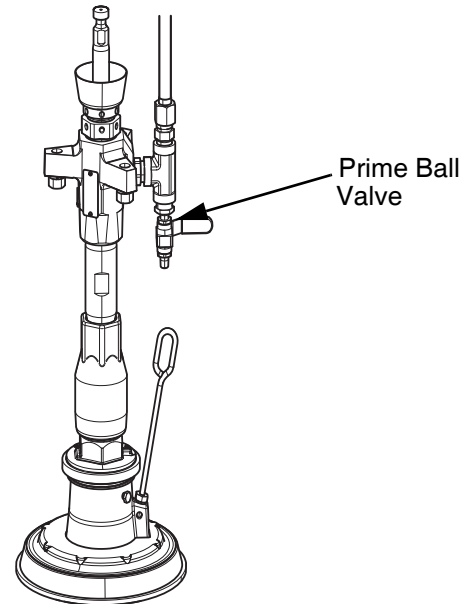

3. To relieve pressure on the side leading out to the stack from the dosing valves, ensure the material outlet valves are open on the A and B side.

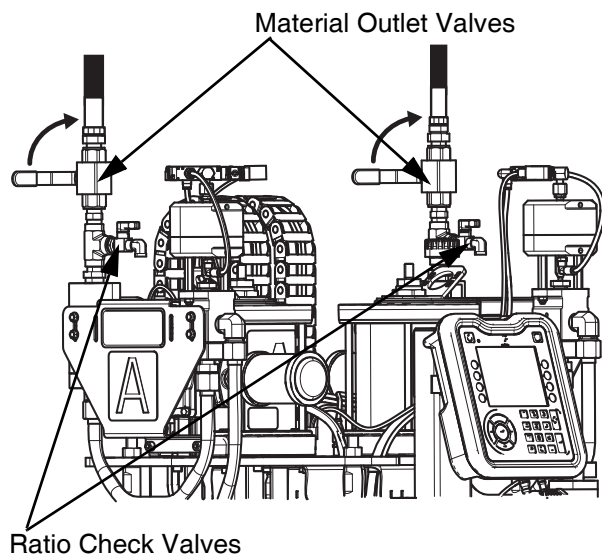



4. Open the ratio check valve on both the A and B side to relieve pressure.

NOTE: This procedure relieves air pressure from the entire system.

F4-55 Caster Kit, 24X218

This kit is for attaching casters to the F4-55 and F4-55-5 models that do not have casters installed at the factory. See page 29 in **Parts** for part identification.

1. Lift the machine until it is at least 3 in. (8 cm) off the floor.

						
Injury may occur if the machine is lifted and not secured to prevent falling. Rest the machine on stands or blocks while installing the caster kit.						

2. Align the four holes in the white bracket (1) with the holes on the caster (2).
3. Mount the caster to the bracket by inserting four of the hex screws (3) included in the kit through the top of the bracket and securing them to the caster underneath with four hex nuts (4).
4. Torque the nuts to 30-35 ft-lbs (41-47 N•m).
5. Fasten the bracket to the base frame using four of the hex screws (3).
6. Torque the hex screws to 30-35 ft-lbs (41-47 N•m).

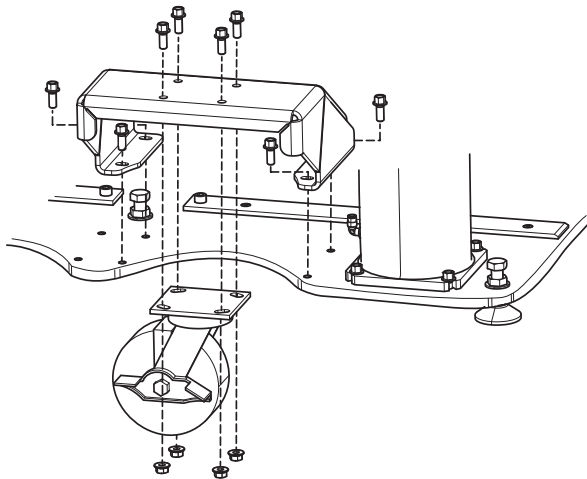

7. Repeat steps 2-6 for the remaining three casters.

Dual Press Kit, 25A102



This kit is needed when using a second press with any of the F4 Series machines.

NOTE: The kit contains one material outlet ball valve. The second press connection uses the outlet ball valve that is already installed on the machine.

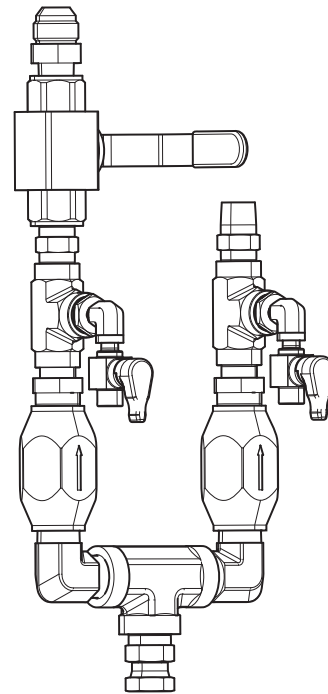

1. Remove the material outlet ball valve and adapter fitting from the machine where you are installing the dual press kit.

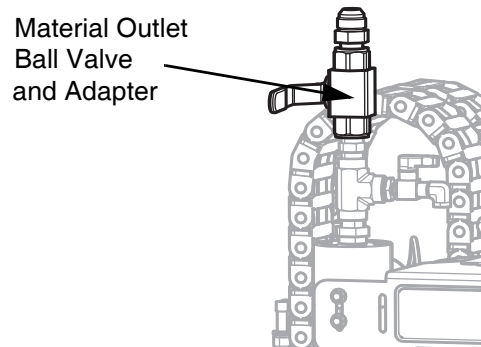

NOTE: Apply tape to all male threads as needed.

2. Attach the valve and the adapter to the dual press kit.

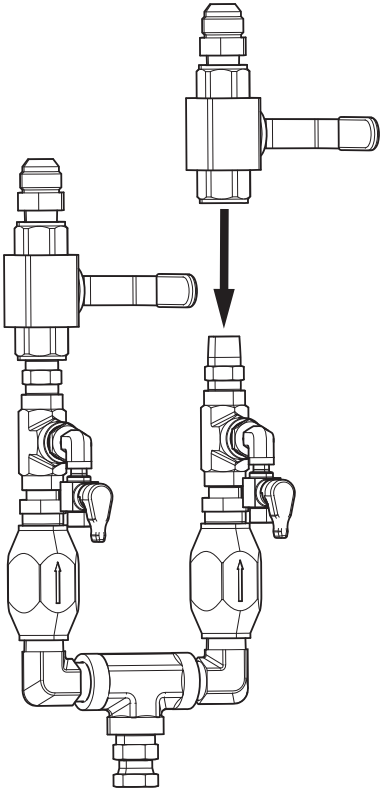

This kit includes a 3/8 in. air line tee that needs to be installed at the machine's air line outlet port when connecting the air lines to the stacks. See **Mixing Stacks Supported** on page 10 for more information.

Location of air line outlet port on the F4-5.

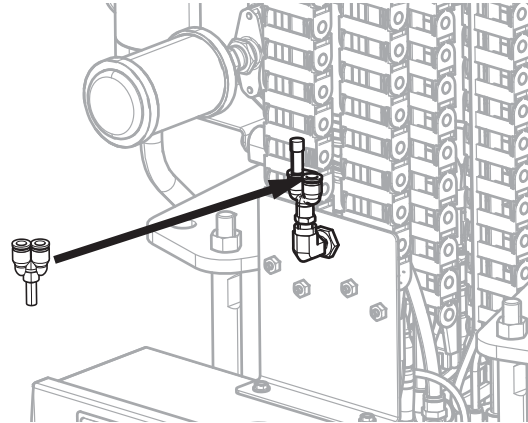

Location of air line outlet port on the F4-55 and F4-55-5.

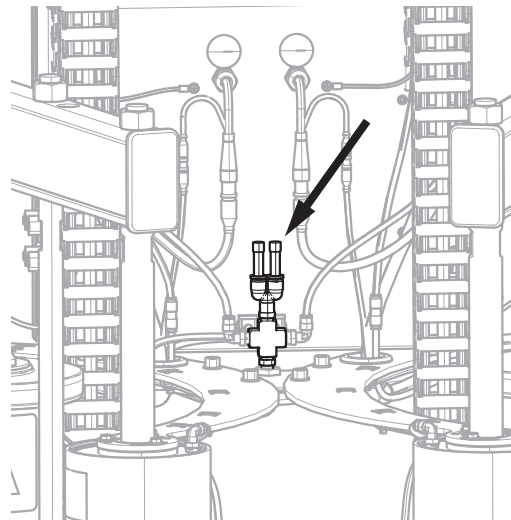

3. Attach the dual press kit to the material outlet connection on the machine where you removed the original outlet ball valve.
4. Tighten all connections.
5. Connect the material hoses to the dual press kit. The material hose connections are 12 JIC flared connections.

NOTE: Do not connect the material hoses to the mixing stacks until after the pumps and material lines have been primed.

Second Press Cable Kit, 25A106

This kit contains cables for making connections from the electronic enclosure to the mixing stack and the press when using a second press with the F4 Series machines. See page 31 in **Parts** for part identification.

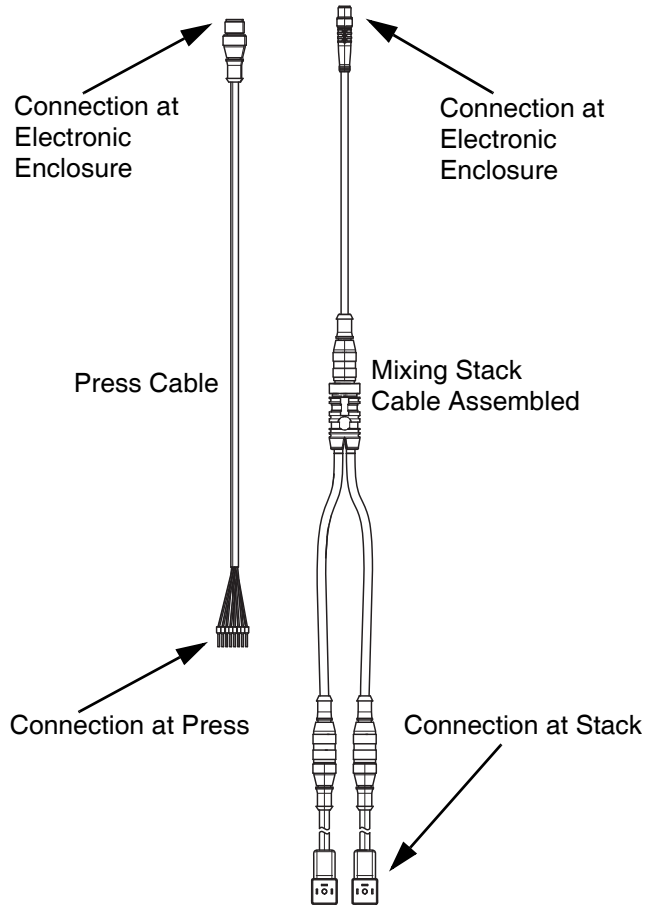

1. Connect the press cable (204) to the electronic enclosure at the connection marked Press 2.
2. Refer to the Fluid Automation F4 Series Setup-Operation manual 335028 for information about connecting the cable to the press.

3. Connect the cable for the mixing stack (201) to the electronic enclosure at the connection marked Stack 2.

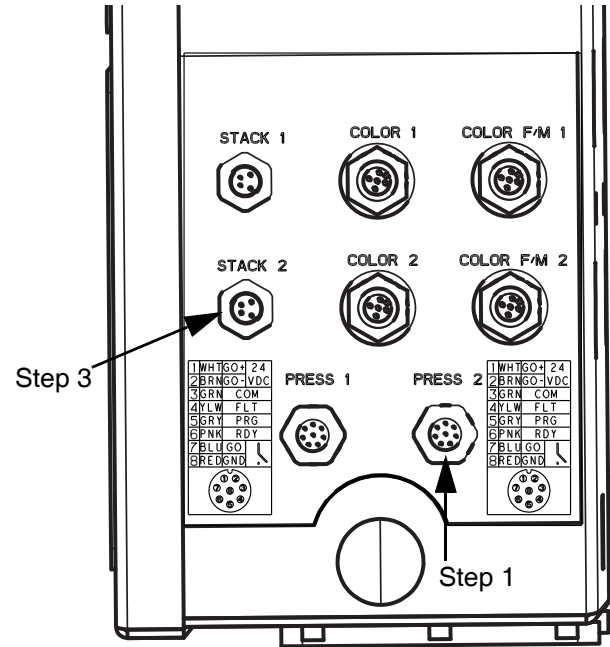

4. Connect the mixing stack cable to the harness splitter (202), and connect the splitter to the two cords (203) in the kit.
5. Connect the cord labeled stack valve 1A to the stack's solenoid block A connector and the cord labeled stack valve 1B to the B connector.

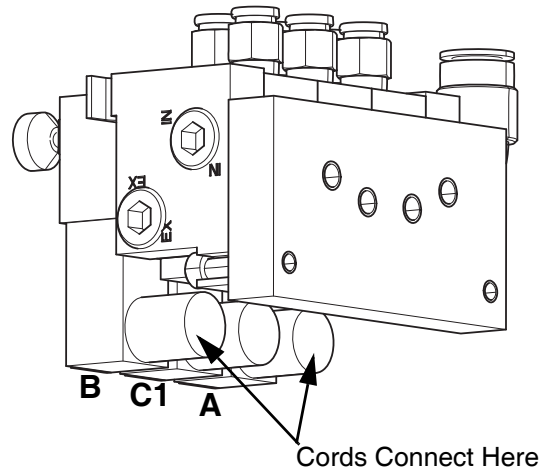

NOTE: The number of solenoid block connectors varies depending on which mixing stack you are using.

Mixing Stacks Supported



There are two types of mixing stack products available with the F4 Series:

- Straight thread stacks
- Tapered thread stacks

Mixing Stacks with Straight Threads

The straight thread mixing stacks offer multi-pass and single-pass mixing options. These stack kits include material in-line filters. For information about in-line filters, see page 16.

On all configurations of the straight thread mixing stacks, the material lines from the F4 machine are connected to the 12 JIC inlets on the stack. If coolant lines (normally chilled water) are being used, they are connected to the 5/16 in (8 mm) water jacket fittings on the mixers. The JIC outlets of the mixer can be adapted as needed to connect to the press or to the material regulator, which would then be connected to the press.

Multi-pass Mixing Stack

The multi-pass stack includes multiple mixing elements to optimize mixing of the material. Three configurations of the mixing stack are available to meet the specific needs of your system.

Kit 25A990 has a manifold, mixer, and regulator but does not include manifold on/off valves, a solenoid block, or a connection for a color injector. The material inlet connections on the manifold are 12 JIC, the water jacket elbow fittings are 5/16 in. (8 mm), and the outlet is 08 JIC.

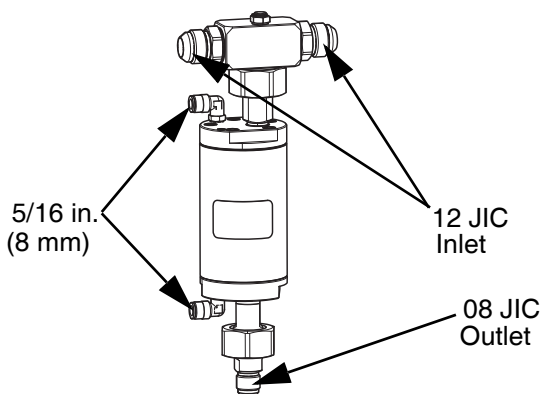

Kit 25A992 has the same components as kit 25A990 and also includes manifold on/off valves and a solenoid block with two solenoids that is designed for systems that are not using a color injector. This kit uses 5/16 in. (8 mm) air line tubing for the air connection between the solenoid block and the manifold valves. There is also a 3/8 in. (10 mm) connection for the stack air inlet.

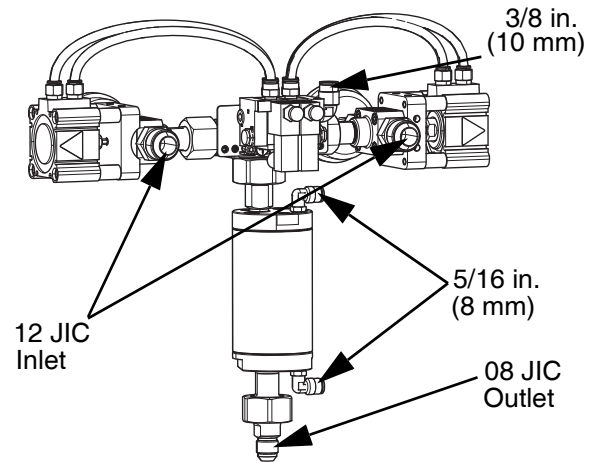

Kit 25A993 has all of the components from kit 25A992 and also includes a color injector (with adapter) and a solenoid block with three solenoids that is designed for use with the color injector. See **Color Injector Kits** on page 22 for more information.

The third solenoid in this kit has two 1/4 in. (6 mm) connections for air line tubing from the color injector.

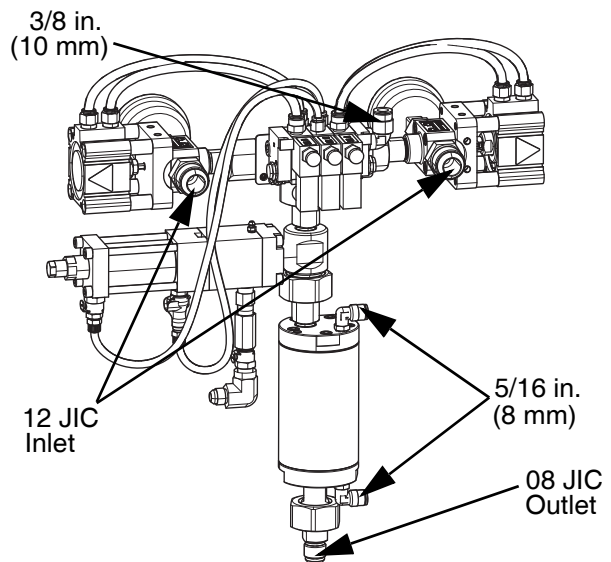

The 25A876 Mixer comes from the factory with 15 mixer cartridges, making a total of 30 mixing elements. It is possible to reduce the pressure drop through the mixer by using fewer mixing elements.

NOTE: Before using the mixer with fewer mixing elements, make sure using fewer elements will still result in acceptable mixing of the material being used.

If 24 mix elements are desired, remove the elements from the passage labeled "C". If 18 mixing elements are desired, remove the elements from the passage labeled "C" and the elements from one of the passages labeled "B". If 12 mixing elements are desired, also remove the elements from the other the passage labeled "B". There should always be 3 cartridges in each of the passages labeled "A". Refer to the parts list on page 35 for assembly notes.

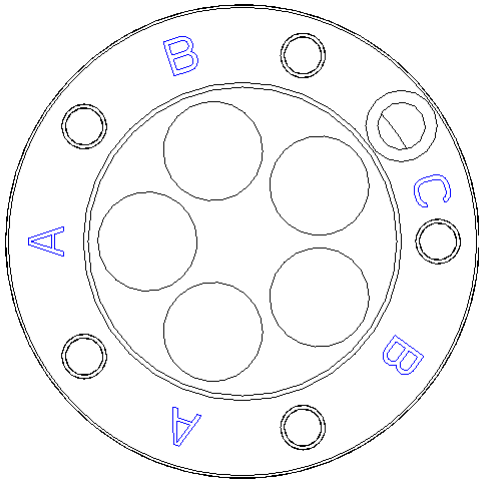

Single-pass Mixing Stack

This single-pass stack is designed for systems that require a higher flow rate. Three configurations are available to meet the specific needs of your system.

NOTE: The air line, material, and water jacket connections are the same for the single-pass mixing stack as the multi-pass stacks.

Kit 25A995 has a manifold, mixer, and regulator but does not include manifold on/off valves, a solenoid block, or a connection for a color injector. The material inlet connections are 12 JIC, the water jacket fittings are 5/16 in. (8 mm), and the outlet is 08 JIC.

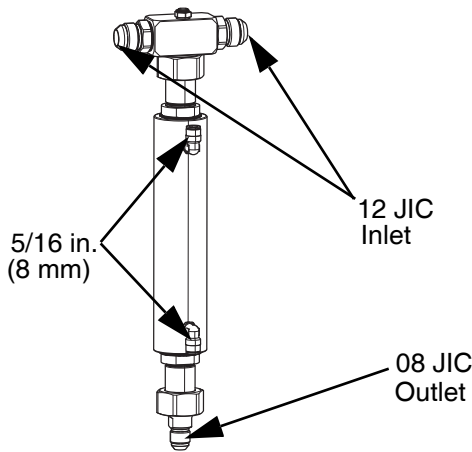

Kit 25A997 has the same components as kit 25A995 and also includes manifold on/off valves and a solenoid block with two solenoids that is designed for systems that are not using a color injector.

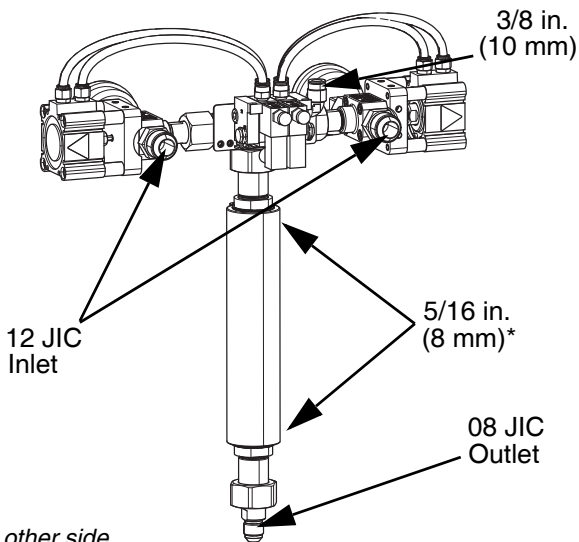

This kit uses 5/16 in. (8 mm) air line tubing for the air connection between the solenoid block and the manifold valves. There is also a 3/8 (10 mm) connection for the stack air inlet.

Kit 25A998 has all of the components from kit 25A997 and also includes a color injector (with adapter) and a solenoid block with three solenoids that is designed for use with the color injector. See **Color Injector Kits** on page 22 for more information.

The third solenoid in this kit has two 1/4 in. (6 mm) connections for air line tubing from the color injector.

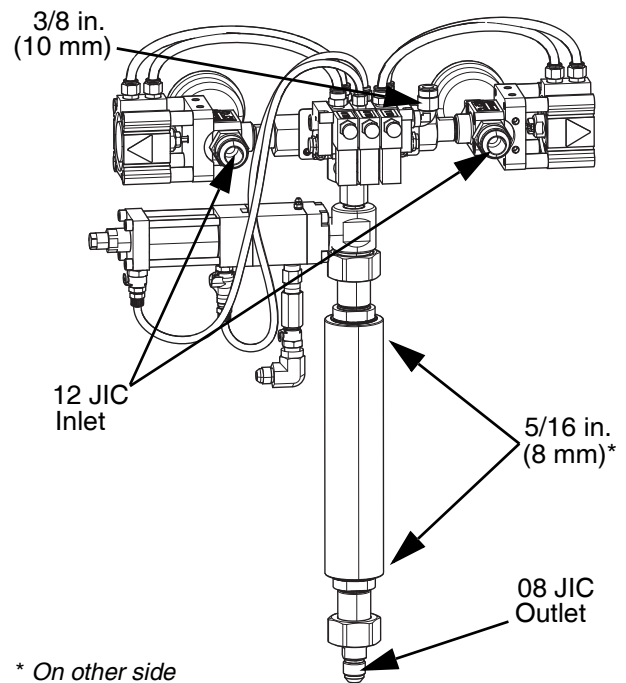

Mini Single-pass Mixing Stack

The mini single-pass mixing stack is intended for applications that require dispensing mini-shots of material. This stack has 1/4 in. mixing elements, holds less amounts of material in the mixer to reduce material waste, and provides continuous cooling of the mixed material.

This stack has 12 JIC material inlet connections and a 5/16 in. (8 mm) water jacket fitting. The outlet is an 06 JIC connector.

A unique feature of this stack is that it includes a combined mixer-material regulator component.

Kit 25C794 includes a third valve that provides additional control for dispensing material based on the needs of your system. This valve has 5/32 in. (4 mm) air fittings.

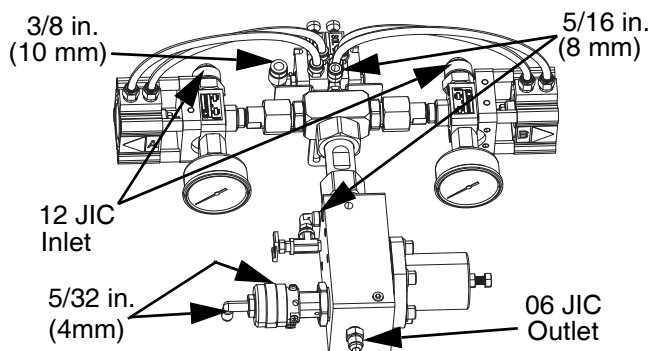

Kit 25C799 has the same components as kit 25C794 except it does not include the third valve for controlling material dispensing.

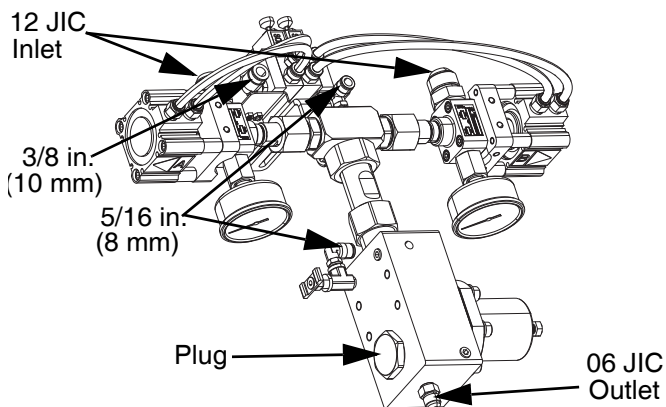

Kit 25C792, which is included as part of kit 25C794, can be purchased and used separately. This kit has the combined mixer-material regulator component with the third valve, but does not include the manifold on/off valves, a solenoid block, or gauges.

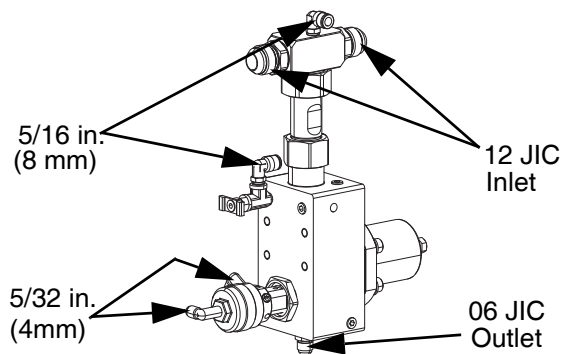

Kit 25D011 is an option for use with kit 25C792 depending on the needs of your system. Kit 25D011 can also be used with kits 25A990 (see page 10) and 25A995 (see page 12). Two 12 JIC to 08 JIC reducing adapters are included in kit 25D011 for systems requiring them. You can also purchase JIC adapters separately. See the part numbers for these adapters on page 55.

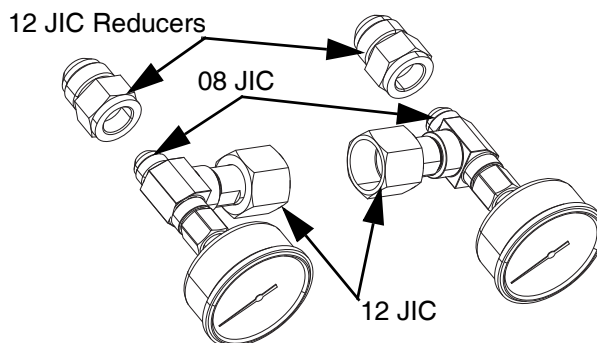

Kit 25C998 is a bracket that can be used to mount kit 25C792 on a press or other location. After the bracket is mounted to the mixer-material regulator component, use 5/16 in. (8 mm) screws (not included) to mount the bracket in the desired location. See page 54 for mounting slot dimensions and the location where the bracket is mounted on 25C792.

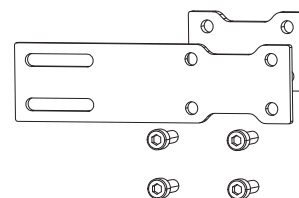

Mixing Stacks with Tapered Threads

There are three models of mixing stacks that have tapered threads and come without in-line filters. Each of these stacks uses 1/4 in. (6 mm) air line tubing for the air connection between the solenoid block and the manifold valves. The material line inlet connections are 12 JIC and the water jacket elbow fittings for the cooling lines are 1/4 in. (6 mm) for all three models.

The mixing stack you choose depends on the needs of your system.

Kit 24R681 has a mixer with 24 5/8 in. (16 mm) mixing elements and a high flow rate. This stack kit has a 3/4 in. (19 mm) outlet fitting for connecting to the press.

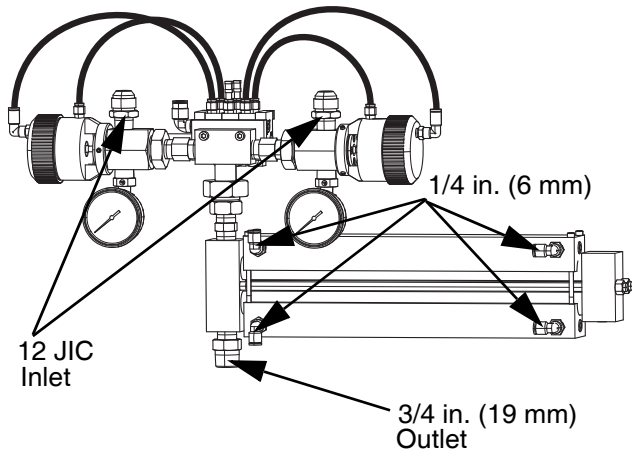

Kit SK556 has a mixer with 12 5/8 in. (16 mm) mixing elements that provides a higher flow rate. This stack kit has a 3/4 in. (19 mm) outlet fitting for connecting to the press.

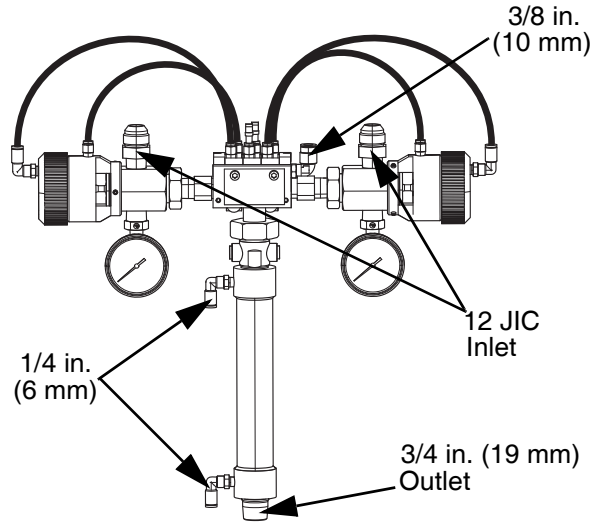

SK556-2A Option

Each of these three stack kits have a port for at least one color injector. Mixing stack SK556 also has an option available for a second color injector solenoid on the solenoid block.

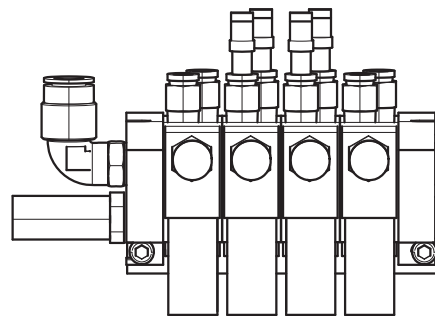

Kit 25A169 also has 24 3/8 in. (10 mm) mixing elements but the mixer is smaller, which results in a lower flow rate. This stack kit has a 1/2 in. (13 mm) outlet fitting for connecting to the press. There is also a 3/8 (10 mm) connection for the stack air inlet.

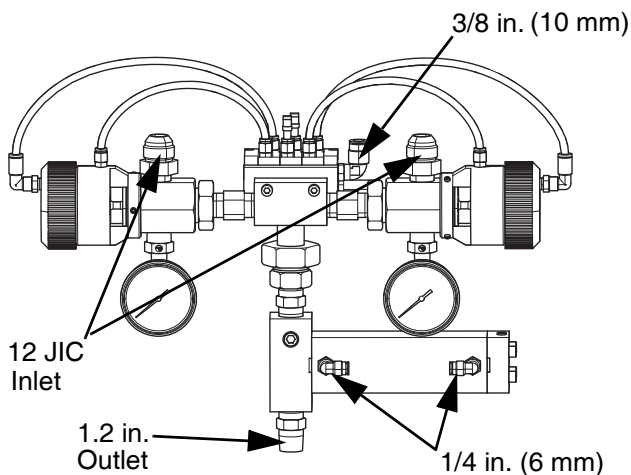

Installing the Stack Kits

The installation steps are similar on all models of the mixing stacks. Mounting the stack onto the press varies depending on the type of press being used.

NOTE: For information about using the material in-line filters or the material regulators as part of the installation, refer to page 16 for the in-line filters and page 18 for the material regulators.

1. If you choose a stack with a solenoid block, it comes already mounted on the stack. If you need to install or replace a solenoid block, ensure that it is mounted on the opposite side of the stack from the pressure gauge faces.
2. Run the 3/8 in. (10 mm) air inlet tubing included in the kit from the machine and connect it to the air inlet on the stack. (Stack 25A169 is shown below.)

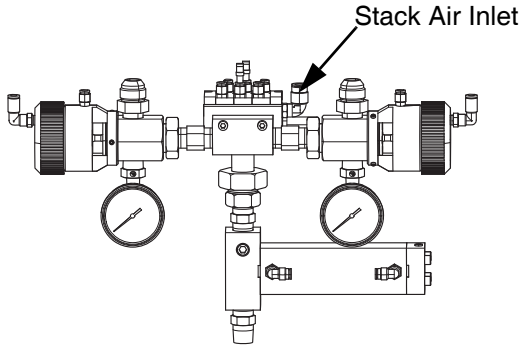

NOTE: If two stacks are being used with a dual press setup, use the 3/8 in. air line tee included with the dual press kit (25A102) for the connection at the machine. See **Dual Press Kit, 25A102** on page 7 for information.

3. The 1/4 in. (6 mm) or 5/16 in. (8 mm) air line tubes (depending on the model) are already connected at the stack. To replace or reinstall the air line tubes, connect them as follows when looking at the side of the stack opposite from the pressure gauge faces. (Stack 24R68 is shown below.)
 - Connect the air line tubes from the forward solenoid ports to the two closer fittings on the manifold on/off valves.
 - Connect the air line tubes from the back ports to the two fittings at the ends of the manifold on/off valves.

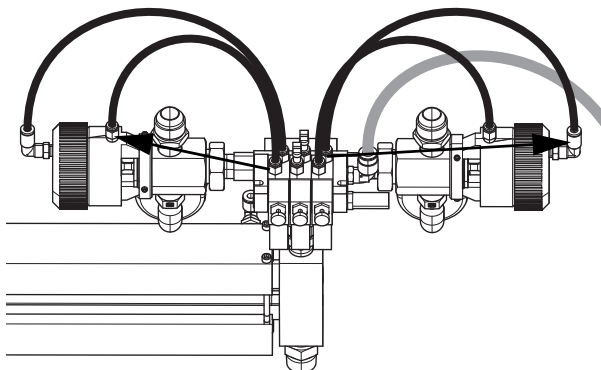

4. After the pumps and material lines have been primed, connect both the A and B material outlet hoses to the stack. See the Fluid Automation F4 Series Setup-Operation manual 335028 for more information. (Stack 25A992 is shown below.)

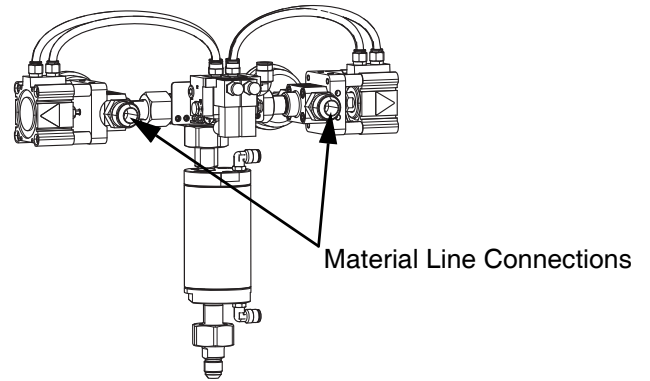

5. Connect the cables from the electronic enclosure to the solenoids as shown below. Always use the Stack 1 connection at the electronic enclosure if only using one press. See page 9 for a diagram of the electronic enclosure's connections.

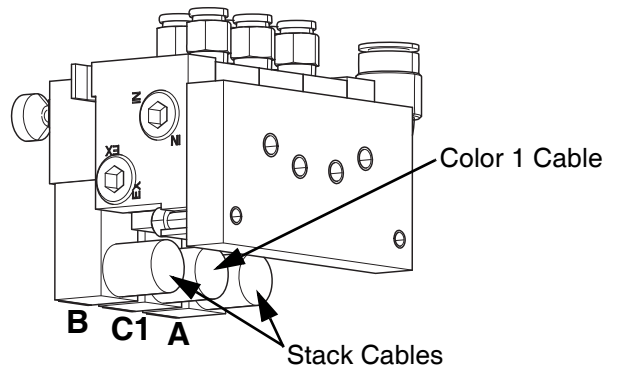

NOTE: The solenoid block on mixing stack kit SK556-2A has an extra solenoid for a second color injector (C2). Connect the cable from Color 2 on the electronic enclosure to the C2 connection.

NOTE: Mixing stacks 25A992, 25A997, 25C794, and 25C799, are configurations that do not utilize a color injector. With these models, there are only two solenoids on the solenoid block for stack cable connections. Solenoid add-on kit 25B009 can be used to add another solenoid to the block if needed.

NOTE: All of the stacks have push-to-connect fittings to circulate fluid for presses that use chillers.

Using Straight Thread Mixers with Tapered Thread Stacks

The multi-pass and single-pass mixing elements included with the straight thread mixing stacks can be used with tapered thread mixing stacks using an optional adapter (part no. 17M397).

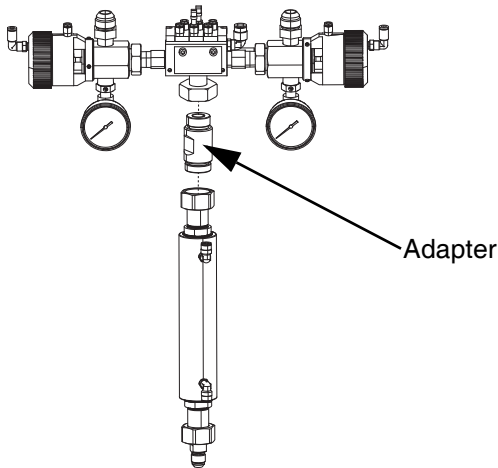

Connect the 1-1/4 in. end of the adapter to the tapered thread stack's manifold and the 1-3/8 in. end of the adapter to the mixer (25C003 shown). Tighten the connections at both ends until secure.

See **Manifold Assembly, SA914-3A/-5A** on page 63 for part information.

Material In-line Filters

Material in-line filters are installed between the mixing stack and the press. They filter the material coming from the stack to help prevent clogging.

The straight thread mixing stacks include a factory-installed in-line filter. See **Mixing Stacks Supported** on page 10. The material in-line filters described here are used with the mixing stacks as shown below.

In-line Filter	Mixing Stacks
SA925-1A (3/4 in.)	24R681, 25A169, SK556
SA926-1A (1/2 in.)	24R681, 25A169, SK556
25A983*	25A990, 25A992, 25A993, 25A995, 25A997, 25A998
* Replaces the factory-installed in-line filters.	

NOTE: In-line filter 25A983 cannot be used with the mini single-pass mixing stacks.

In-line Filter, SA925-1A

NOTE: Material in-line filter SA925-1A can only be used with tapered thread mixing stacks.

This filter is for a 3/4 in. NPT connection (both input and output). If a material regulator is used, the filter should be installed between the stack and the regulator.

NOTE: The 3/4 in. material filter provides a higher flow rate than the 1/2 in. filter.

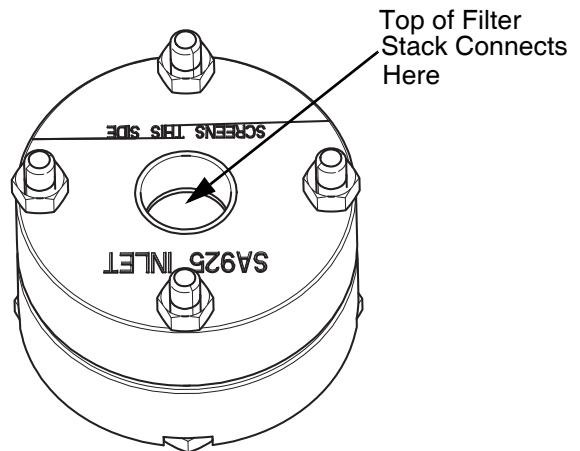

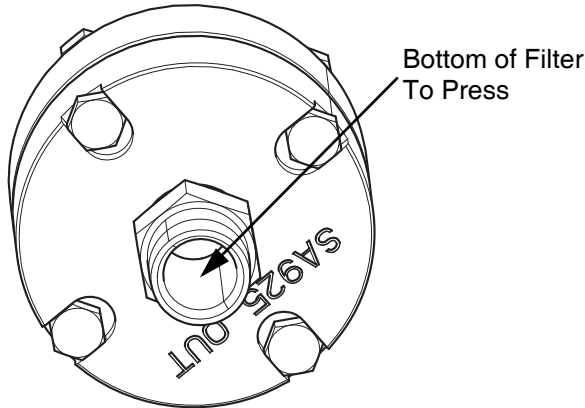

In-line Filter, SA926-1A

NOTE: Material in-line filter SA926-1A can only be used with tapered thread mixing stacks.

This filter is for a 1/2 in. NPT connection (both input and output). If a material regulator is used, the filter should be installed between the stack and the regulator.

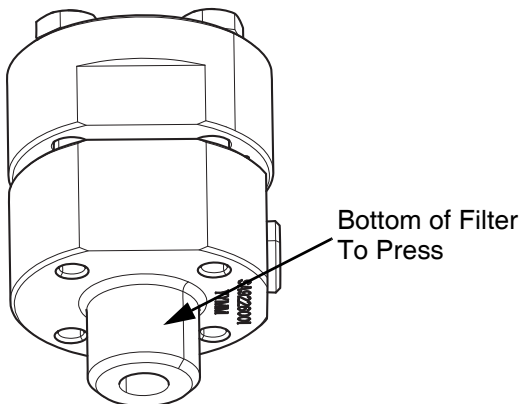
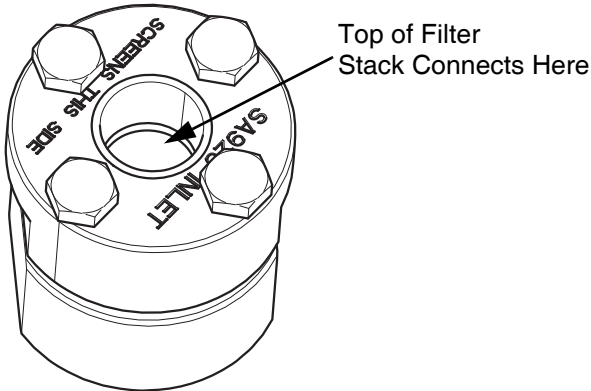

In-line Filter, 25A983

NOTE: Material in-line filter 25A983 can only be used with straight thread mixing stacks.

This filter provides a high flow rate and can be installed on both the multi-pass and single-pass mixing stacks, except for the mini single-pass stack. The input and output connections for the filter are 1-3/8 in. (35 mm).

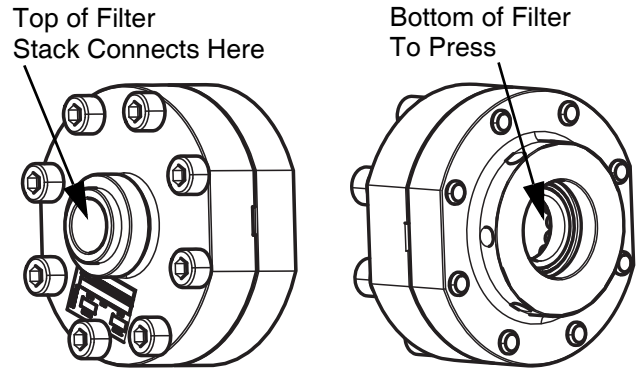

This filter is installed at the end of the mixer, between the mixer and a material regulator.

Installing in-line filter 25A983 on the straight thread mixing stack kits requires first removing the factory-installed in-line filter.

1. Loosen the nut at the bottom of the mixer and disconnect it from the 08 JIC filter fitting.
2. Remove the three screens and the filter support as shown below. Leave the o-ring when installing the new in-line filter.

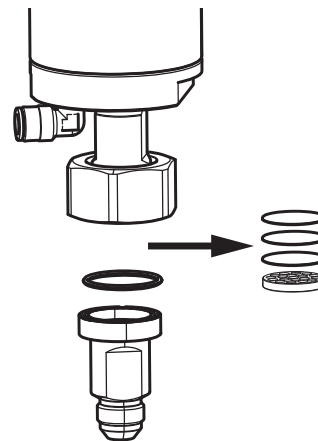

3. Connect the 08 JIC filter fitting to the bottom of in-line air filter 25A983.
4. Attach the top of the filter to the stack's mixer.
5. Attach material regulator 25A986 to the 08 JIC filter fitting.

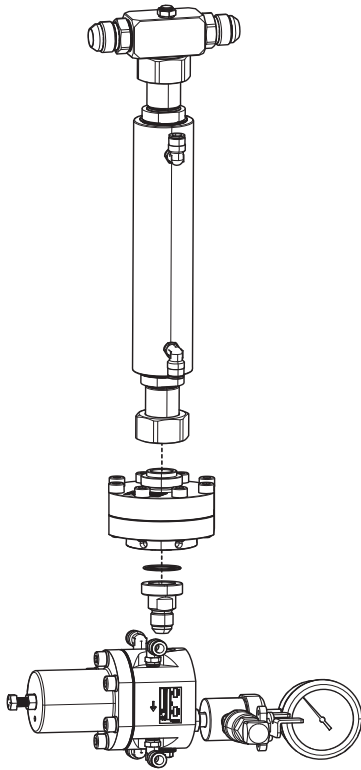

NOTE: Replacement kits are available for the factory-installed in-line filters. See **In-line Filter Replacement Kits** on page 38.

Material Regulators

Material regulators help to reduce pressure fluctuations and provide a more consistent material feed pressure into the press. The regulator is installed between the mixing stack and the press. If an in-line filter is used, the regulator is installed after (below) the filter.

NOTE: The mini mixing stacks 25C792, 25C794, and 25C799 do not require a material regulator as each kit includes a combined mixer-material regulator component.

Material Regulator, 25A986

NOTE: Material regulator 25A986 is used with straight thread mixing stacks.

Two configuration options are available for this material regulator. The only difference between the two configurations is that one includes a gauge to monitor outbound pressure and the other does not include the gauge.

The input and output connections for this material regulator are 08 JIC.

See page 46 in **Parts** for more information.

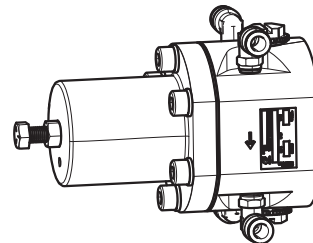
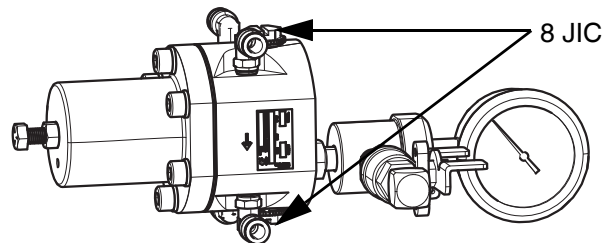

Two regulator options are offered for the tapered thread mixing stacks 24R681, 25A169, and SK556. Both regulators include a gauge for monitoring pressure

Material Regulator, SA921-G

NOTE: Material regulator SA921-G is used with tapered thread mixing stacks.

This regulator is for a 3/4 in. NPT connection (both input and output) and would be used with material in-line filter SA925-1A.

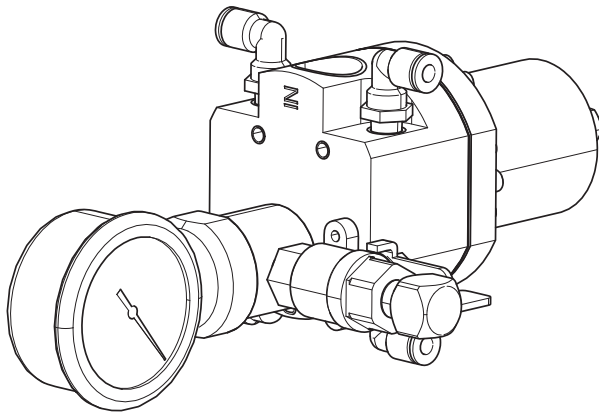

Material Regulator, SA920-G

NOTE: Material regulator SA920-G is used with tapered thread mixing stacks.

This regulator is for a 1/2 in. NPT connection (both input and output) and would be used with material in-line filter SA926-1A.

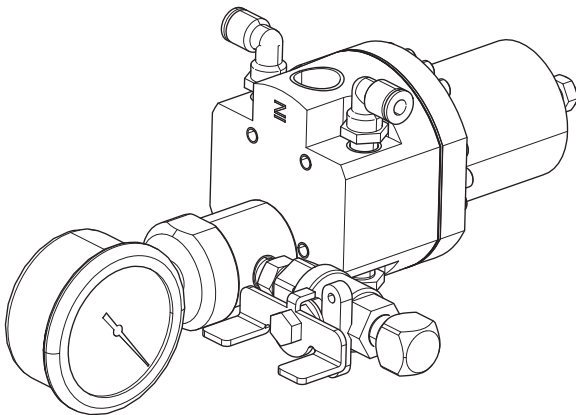

Material Regulator Features

All four of the material regulators described in this section have a pressure adjustment control that allows you to manually increase or decrease output pressure. Turn the adjustment control clockwise to increase pressure and counterclockwise to decrease pressure.

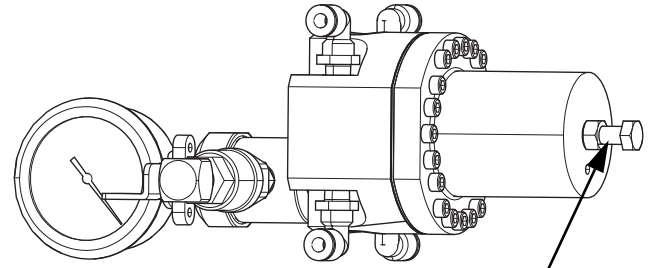

Pressure Adjustment

On all of the regulator models, the input line is connected to the port marked IN and the output line is connected to the port marked OUT. All models include a ball valve for bleeding the line, if needed.

Also, the regulators have push-to-connect fittings to circulate fluid for press configurations that use chillers.

NOTE: A diaphragm isolator is located between the gauge and fluid regulator. This is to prevent material from curing inside the gauge. Material still may cure inside the diaphragm isolator on the fluid regulator side, which could prevent accurate pressure readings. Periodic maintenance helps to ensure proper functionality.

Colorant Tank Kits



There are two sizes of colorant tanks available, one for the F4-5 and one for the F4-55 and F4-55-5.

Colorant Tank Kit, 25A104

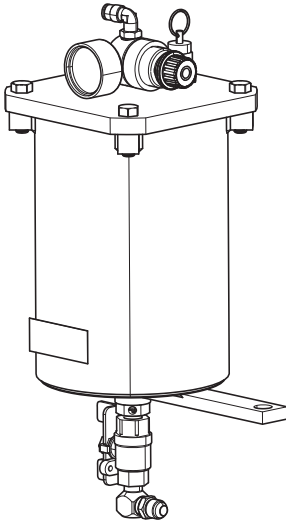

This colorant tank is for use with the F4-5 and holds up to 3 qt (3 liters) of color material. See page 72 in **Parts** for part identification.

1. To mount the tank to the F4-5, remove two of the existing bolts on a ram cylinder and attach the colorant tank bracket (3610) using the two screws (3609) provided in the kit.

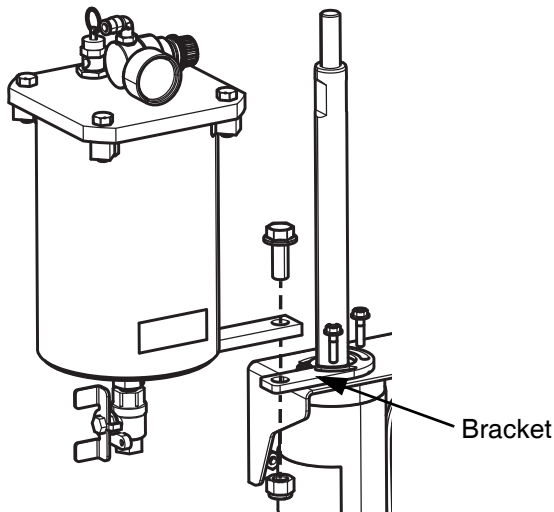

2. Connect the tank to the bracket using the screw (3611) and nut (3612) provided in the kit.
3. Ensure all screws are tight to secure the tank.

Colorant Tank Kit, 25A105

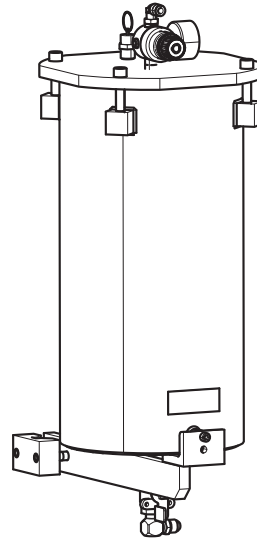

This colorant tank is for use with the F4-55 and F4-55-5 and holds up to 3 gal. (11 liters) of color material. See page 74 in **Parts** for part identification.

1. To mount the tank to the machine, attach the white tank bracket (3813) to a ram cylinder using the four hex screws (3806) included in the kit.

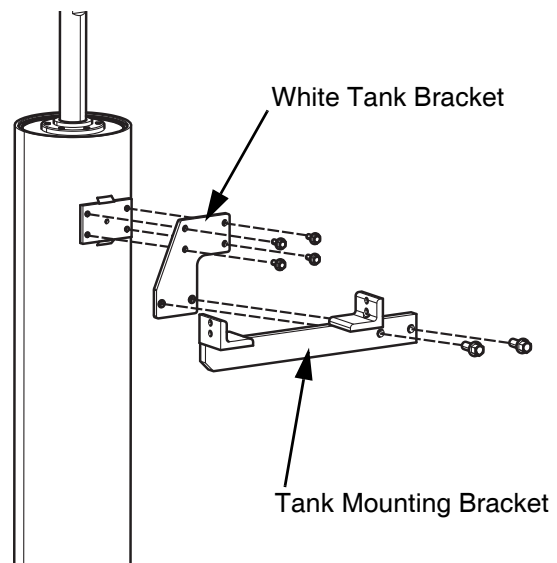

2. Attach the tank mounting bracket (3809) to the white tank bracket using two hex screws (3812) included in the kit.
3. Ensure all screws are tight to secure the tank.
4. Attach the colorant tank to the mounting bracket using two socket head screws (3810) included in the kit.

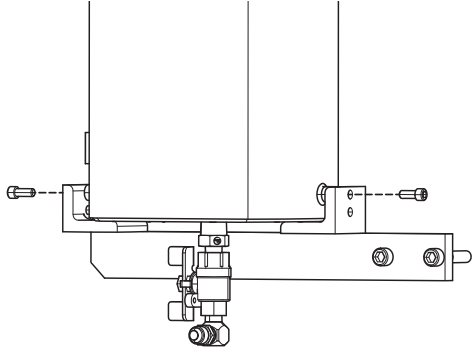

3. Connect the other end of the 1/4 in. tubing to the colorant tank air regulator on the top of the tank.

Tank Air Line Connection

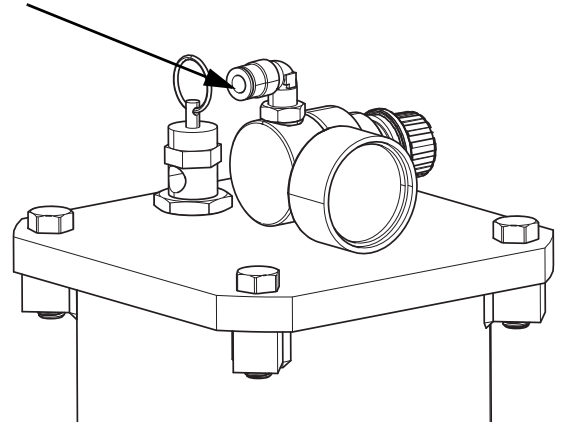

4. Connect the color material line to the 06 JIC connector at the bottom of the tank.

Air Line and Color Material Line Connections

The air line and material line connections are handled the same way for both tank kits.

1. At the machine, remove the 3/8 in. plug from one of the air line connections and replace it with the 3/8 in. x 1/4 in. reducer included in the kit.

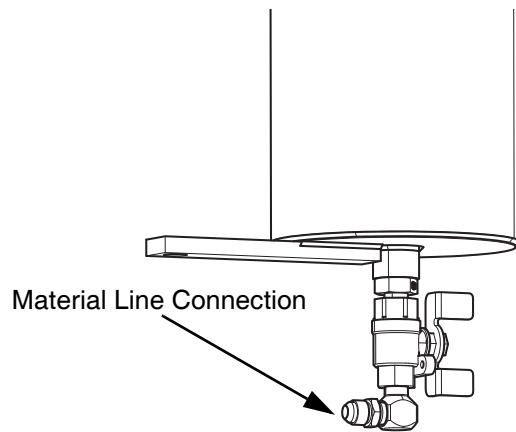
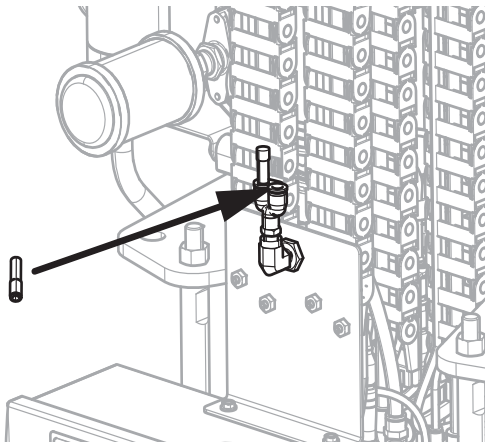

Material Line Connection

NOTE: The connection for the material line depends on if you are using a color flow meter or not. See **Color Flow Meter Kits** and **Color Injector Kits** on page 22 to complete installation.

2. Connect the 1/4 in. tubing that is included with the kit to the reducer at the machine.

Color Flow Meter Kits

The color flow meter provides feedback to the system about the flow of the color material and automatically adjusts to maintain the color setpoint, based on the feedback and the settings in the Advanced Display Module (ADM).

NOTE: There are two color flow meter kits available for use with the F4 Series. Kit **25A103** can be used for most color materials. Kit **25A161** should be used for high viscosity material.

NOTE: See the Fluid Automation F4 Series Setup-Operation manual 335028 for information about calibrating the color flow meter and color injector.

1. Connect the colorant tank's material line to the 06 JIC inlet connection on the color flow meter. See **Colorant Tank Kits** on page 20.
2. Connect the color material line from the color injector to the 06 JIC outlet connection on the flow meter.
3. Connect the cable included with the color flow meter kit to the cable connection on the flow meter.

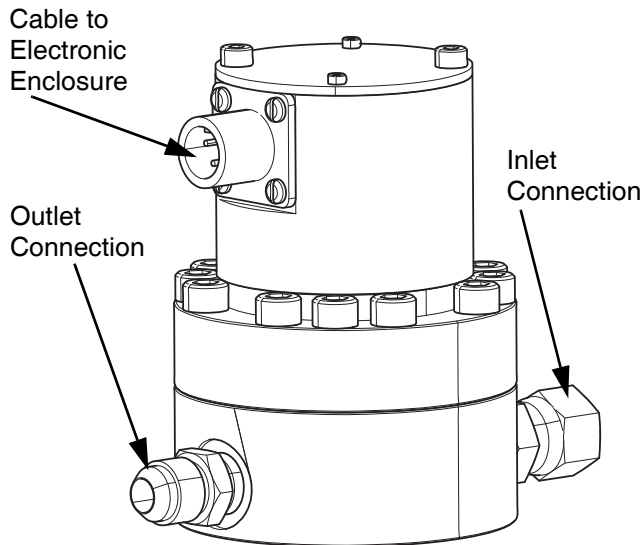

4. Connect the other end of the cable to the electronic enclosure at one of the Color F/M connections. See page 9 for a diagram of the electronic enclosure's connections.

NOTE: Always use Color F/M 1 if you are only using one press. Color F/M 2 can be used for the second connection in a dual press configuration, or if two injectors are used on a single press.

Color Injector Kits

The color injector connects to the mixing stack and is used to add color to the silicone material so it can be mixed in the stack prior to being dispensed by the press.

NOTE: There are two color injector kits available for use with the F4 Series. Kit **25C478** is used with straight thread mixing stacks and kit **25A108** is used with tapered thread stacks.

Install 25C478

Two configurations (25A993 and 25A998) of the straight thread mixing stacks come with color injectors already installed. If you need to replace the color injector or want to install a color injector on another straight thread stack, use kit 25C478.

Mount color injector 25C478 onto the stack as shown below. (Stack 25A993 is shown.)

1. Loosen the nut (part no. 17L385) at the top of the mixer and separate the mixer from the manifold assembly.
2. Connect the color injector kit to the mixer and manifold assembly and torque the nuts to 25-30 ft-lbs (30-40 N•m).

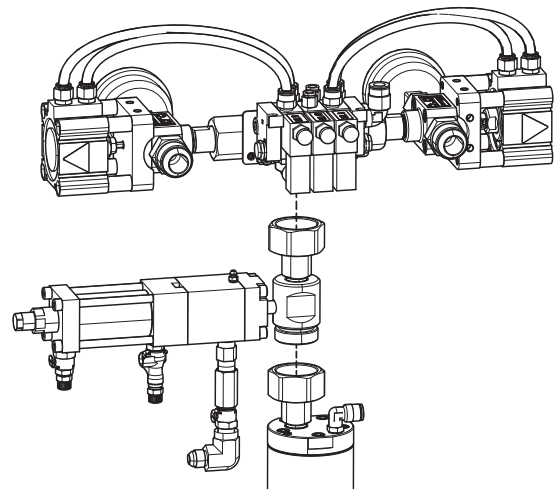

Install 25A108

Color injector 25A108 is connected onto the stack at the mixer as shown below. (Stack 24R681 is shown.) Apply ceramic tape to the NPT threads on the color injector prior to mounting it on the mixer.

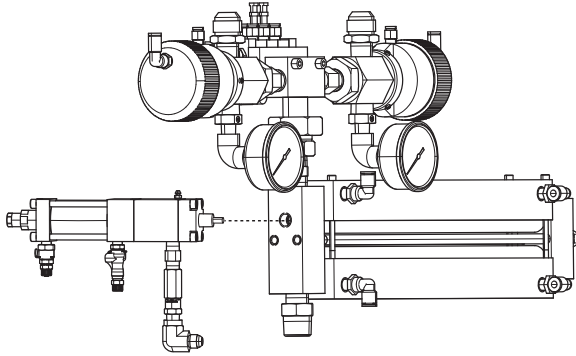

2. Connect the 1/4 in. air line tubes from the color injector to the injector solenoid on the stack.

Inject Color Air Hose Connects Here Retract Injector Air Hose Connects Here

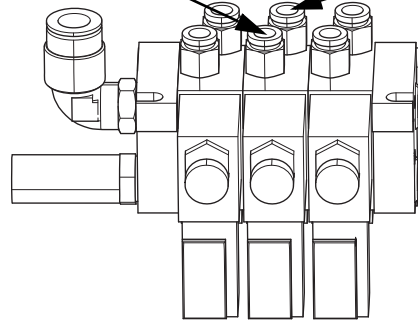

3. Connect the cord included with the kit to the stack's solenoids at C1. See page 48 (25C478) or page 69 (25A108) in **Parts** for part identification.

Color Injector Connections

The following steps apply to both 25C478 and 25A108.

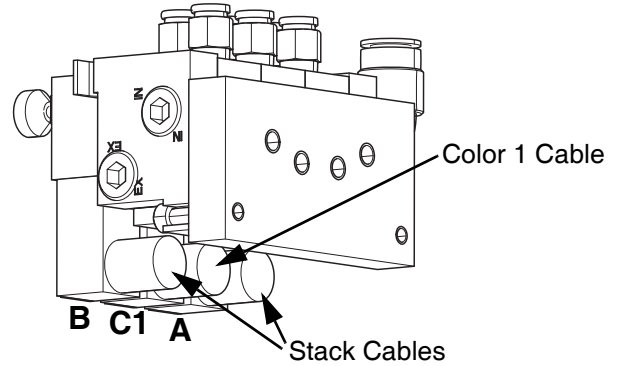
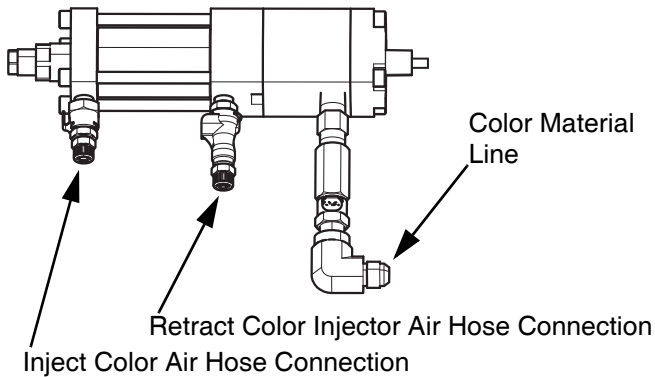

1. Attach the color material line from either the colorant tank or the color flow meter (depending on the configuration) to the color injector using the 06 JIC quick disconnect.



4. Connect the other end of the cord to the cable included in the kit and connect the cable to the electronic enclosure at the Color 1 connection. See page 9 for a diagram of the electronic enclosure's connections.

NOTE: The disconnect has a check mechanism on both sides to prevent colorant from pouring out when not attached.

Continuous Level Sensor Kits

						
---	---	---	--	--	--	--

Do not install these sensors while the machine is operating or when air is supplied to the system. Removing hex nuts from the ram assemblies while the machine is operating could cause personal injury or damage the machine. Follow the **Pressure Relief Procedure** on page 6 before proceeding with installation.

The continuous level sensors are designed to measure the amount of material left in the drums and provide feedback to the system. The material ratio can then be adjusted so the drums are emptied at the same time.

Continuous Level Sensor, 25A100

This sensor kit is for the F4-55 and F4-55-5. It includes two sensors, each with a bracket and hardware for mounting the sensors to the machine. This kit also includes cables for connecting each sensor to the continuous level cables running from the electronic enclosure. See page 77 in **Parts** for part identification.

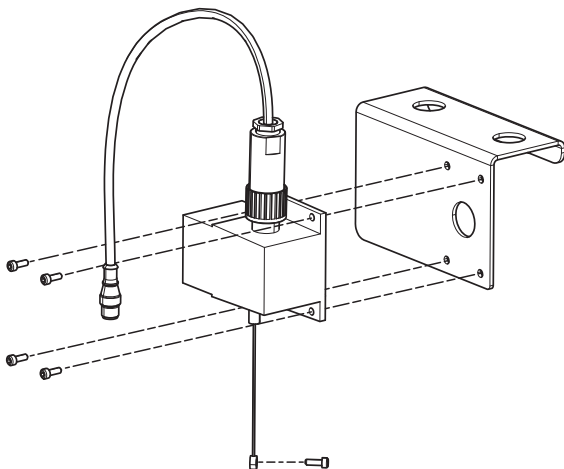

Follow these steps to install the sensors on both the A and B sides.

1. Remove the hex nut from the bolt on the end of each ram beam nearest to the electronic enclosure.
2. Using the screws (4103) included in the kit, attach each of the string pot sensors (4103) to the brackets (4101).

3. Mount the sensor with the bracket as shown below and attach and tighten the hex nuts on the ram beams until secure.

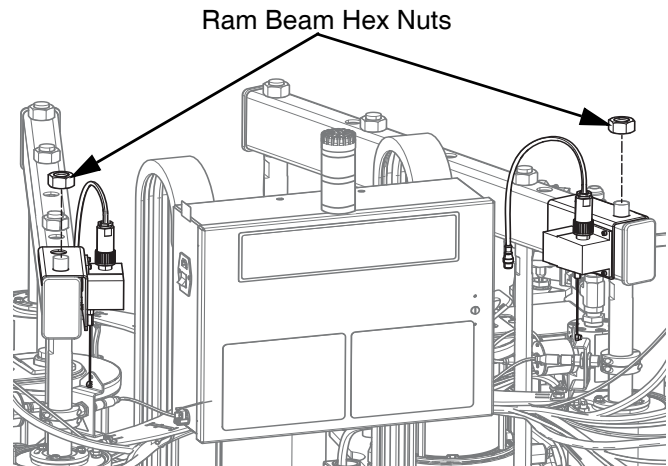

4. Connect the cables (4104) included in the kit to the top of the string pot sensors (4101).
5. These cables then attach to pre-installed cables that run from the electronic enclosure through the cable track and hose guide. Look for the cables marked E located near the A and B air motors. Connect them to the cables (4104) running from the sensors.

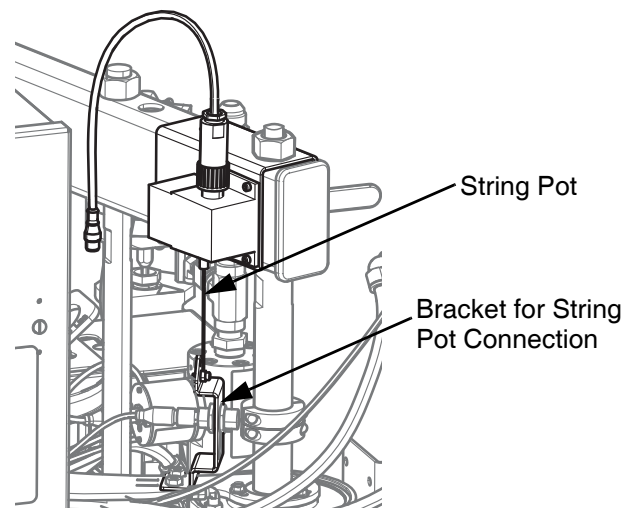

6. Attach the string pots (4102) to the string connection brackets located on the electronic enclosure brace. Use the screws (4103) included in the continuous level sensor kit to attach the string to the bracket on each side.

- Adjust the height of the pre-installed leveling clamps to 5.38 in. (137 mm) from the bottom of each ram beam to the top of the leveling clamps.

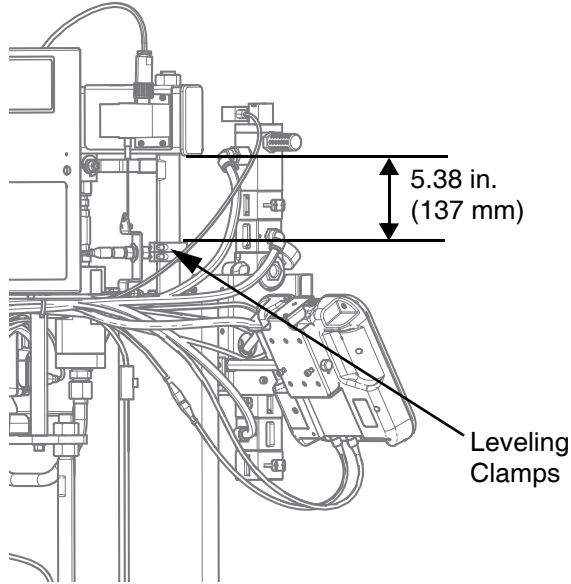

Continuous Level Sensor, 25A101

This sensor kit is for the F4-5 and includes two sensors, each with a bracket for mounting to the machine and another bracket for connecting the string pot. This kit also includes cables for connecting each sensor to the continuous level cables running from the electronic enclosure. See page 78 in **Parts** for part identification.

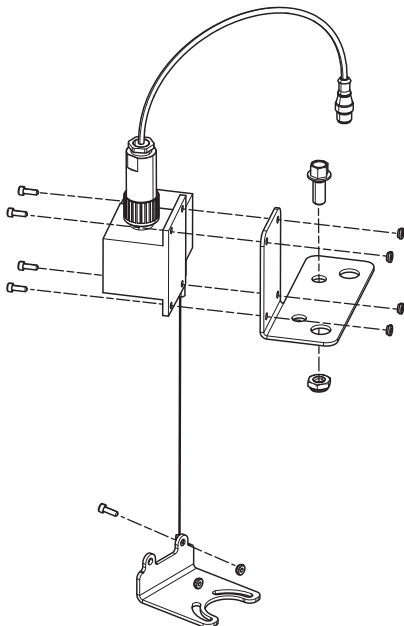

These sensors are mounted on the ram motor plates behind the ADM and light tower.

- Remove the hex nuts from the bolts on each ram motor plate closest to the ADM.
- Using the screws (4205) included in the kit, attach each of the string pot sensors (4203) to the brackets (4201).

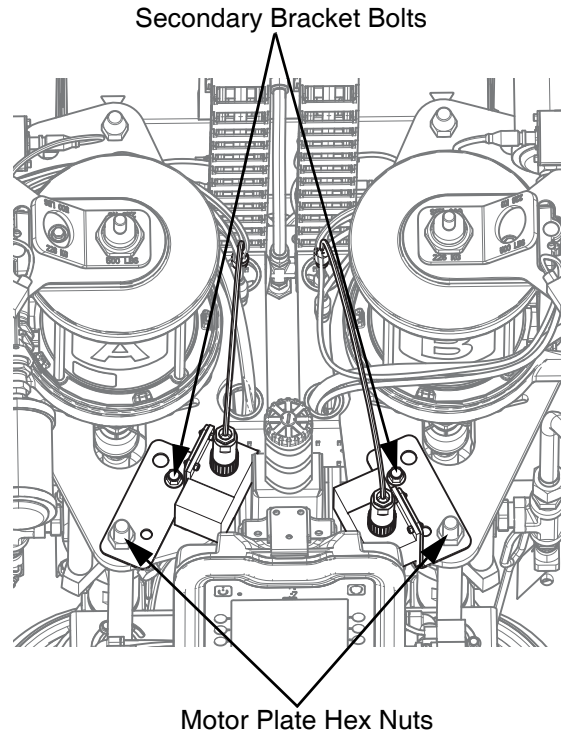

- Mount each sensor with the bracket as shown above and reattach the ram motor plate hex nuts, but do not fully tighten them.
- Add the secondary bracket bolts (4204) included in the kit to orient the sensors as shown above. Secure the bolt with the nuts (4206) included in the kit.
- Tighten the ram hex nuts until secure.
- Connect the cables (4207) included in the kit to the top of the string pot sensors (4203).
- These cables then attach to pre-installed cables that run from the electronic enclosure through the cable track and hose guide. Look for the cables marked E located near the A and B air motors. Connect them to the cables (4207) running from the sensors.

- Remove the screws from the ram brackets next to the piston rods.

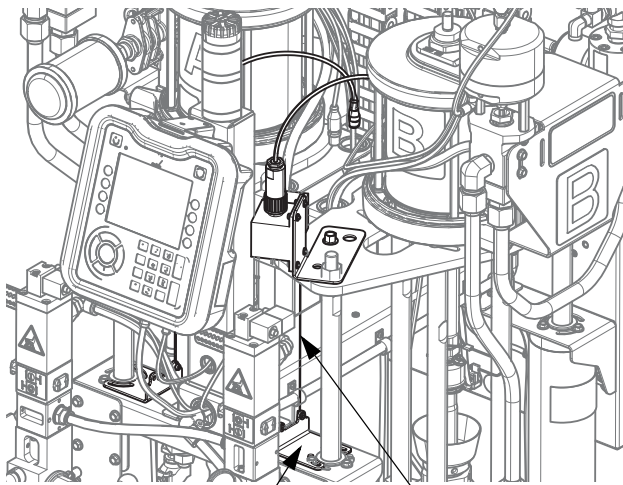

String Connection Bracket String Pot

- Place the string connection brackets (4202) on the ram brackets as shown above and replace and tighten the screws until secure.
- Attach the string pots (4203) to the brackets. Use the screws (4205) included in the kit to attach the string to the bracket on each side.
- Adjust the height of the pre-installed leveling clamps to 3.75 in. (95 mm) from the bottom of each ram motor plate to the top of the leveling clamps.

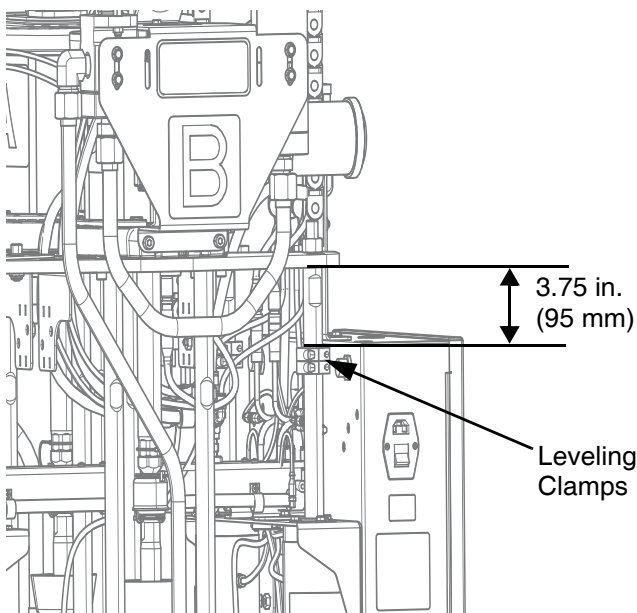

NOTE: See the Fluid Automation F4 Series Setup and Operation manual 335028 for information about setting up and calibrating the sensors in the ADM software.

5-Gallon Pail Girdle, 25A160

This is intended for use with the F4-55 machine. The pail girdle is placed around 5-gallon pails that are used to contain material dispensed from the machine. The pail girdle reinforces the pail to help keep it from cracking or breaking during use.

To place the girdle on a pail, loosen the three clamp handles until the pail fits inside the girdle. Slide the pail into the girdle and tighten the clamp handles until secure.

NOTE: Do not over-tighten the girdle as it could damage the pail.

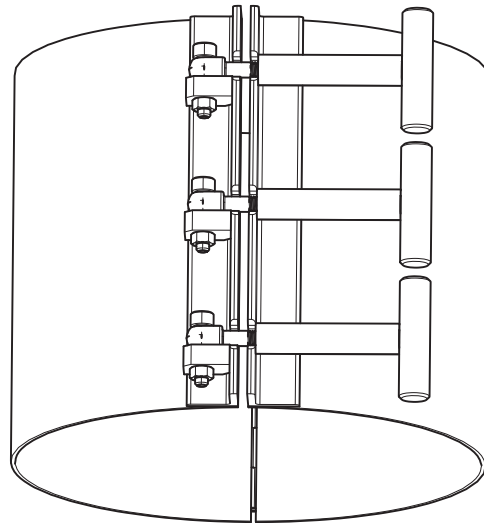

Pressure Transducer Kit, 25C237



The pressure transducer kit is used to monitor mixing stack pressure through the system instead of using the stack's gauges. Pressure information is transmitted by the pressure transducer to the system's ADM.

NOTE: This kit can be used with straight thread or tapered thread stacks. The 1/2 NPT x 08 JIC adapter (4410) included in the kit is required when connecting to a straight thread stack.

There are two pressure transducers in each kit. One end of each is connected to the stack (pressure A and pressure B) and the other end is connected to Fluid Control Module 2 (FCM 2) in the electronic enclosure.

NOTE: A second pressure transducer kit can be used to monitor additional pressures in the system or a second stack. On the ADM, these connections are pressure C and pressure D. When using a second kit, pressure A and B must still be connected to FCM 2 and pressure C and D must be connected to FCM 1.

Follow these steps to install the pressure transducer kit. See page 80 in **Parts** for part identification.

1. Remove both gauges from the stack.
 - a. For tapered thread stacks, install the two pressure sensors by connecting the 1/2 in. NPT pressure transducer adapters (4405) to the stack where the gauges were removed. Use ceramic tape on the NPT fittings.

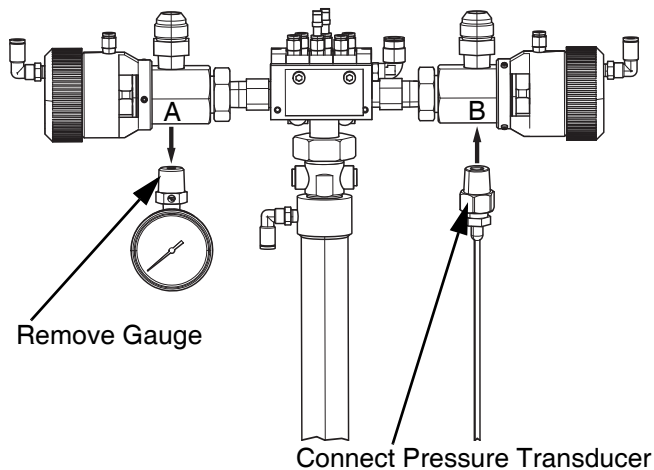

- b. For straight thread stacks, install the 1/2 NPT x 08 JIC adapters (4410) to the stack where the gauges were removed. Then connect the two NPT pressure transducers to the adapters.

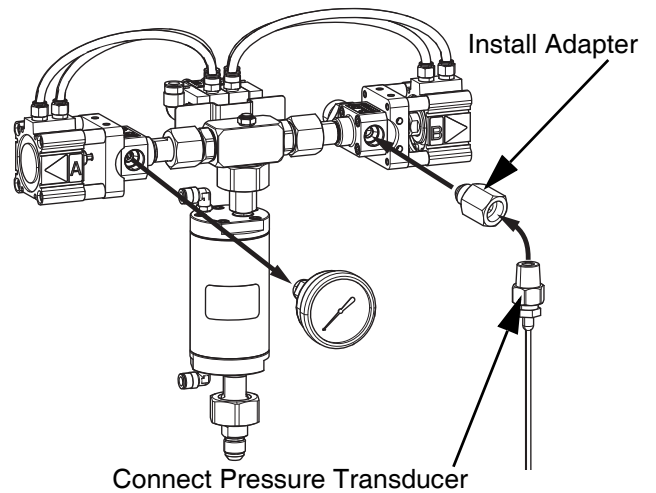

NOTE: The pressure transducers can also be used with the stack adapter kit 25D011 (see page 13). Remove the gauges and install the pressure sensors (4403) directly into where the gauges were removed, as shown below. Do not use the pressure transducer adapters (4405) or the 1/2 NPT x 08 JIC adapters (4410) for this installation.

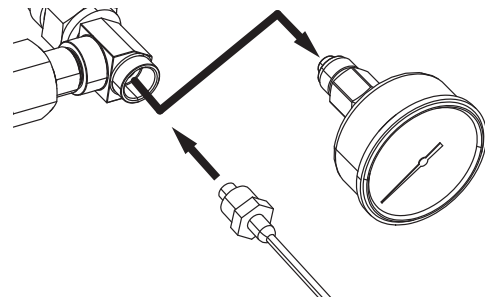

2. Connect each pressure sensor (4403) to the cables (4404) included in the kit and run the cables to the machine's electronic enclosure.

3. Insert the cables through an available opening in the F4 Series machine's electronic enclosure and connect the cable from pressure A on the stack to port 6 and the cable from pressure B on the stack to port 7 on FCM 2.

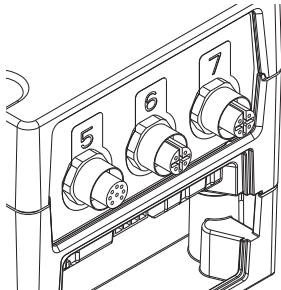

4. If a second pressure transducer is being used on the F4 System, connect the cable into port 6 for pressure C and port 7 for pressure D on FCM 1 as shown below.

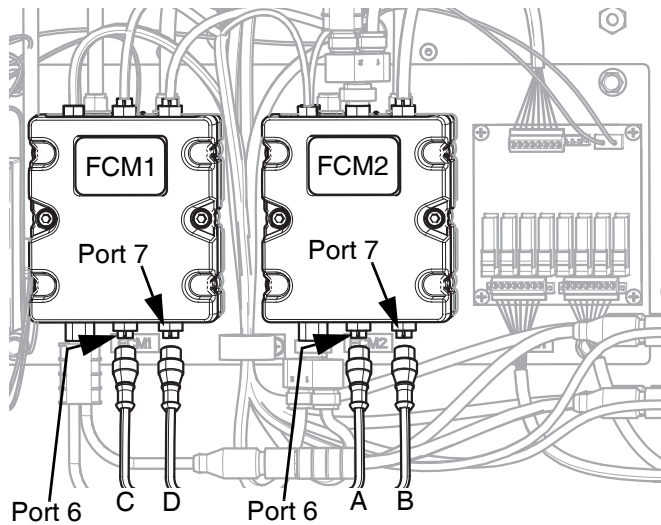

5. Insert the custom software blue token included in the kit into FCM2. This is required to run the machine in small shot mode.

NOTE: See the Fluid Automation F4 Series Setup and Operation manual 335028 for information about the pressure sensor operation in the ADM software.

Using Small Shot Mode

If the pressure transducer kit is being installed to run in small shot mode, the custom software blue token included in the kit must be inserted into FCM2. See the Fluid Automation F4 Series Setup and Operation manual 335028 for more information.

Also, the restrictor that comes with the kit needs to be installed between the outlet of the dosing valve and the stainless steel u-tube that connects to the flow meter on the F4 series machine.

1. Loosen and remove the fittings that connect the u-tube to the dosing valve and flow meter.
2. Insert the restrictor (4108) into the tube with the flange near the top as shown below.

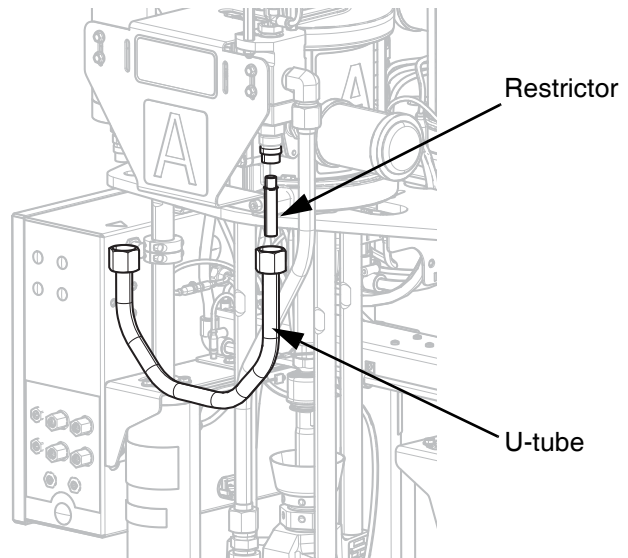

NOTE: If there is material in the tube, clean out enough of it to allow the restrictor to be completely inserted into the tube.

3. Reattach the u-tube to the dosing valve and flow meter and tighten the fittings until secure.

The dosing valve's JIC adapter should fit tightly against the top of the restrictor.

NOTE: When you are using small shot mode, the pressure transducer kit can only be used with a single press. It cannot be used with the dual press kit.

NOTE: See the Fluid Automation F4 Series Setup and Operation manual 335028 for information about running the F4 series machine in small shot mode.

Parts

F4-55 Caster Kit, 24X218

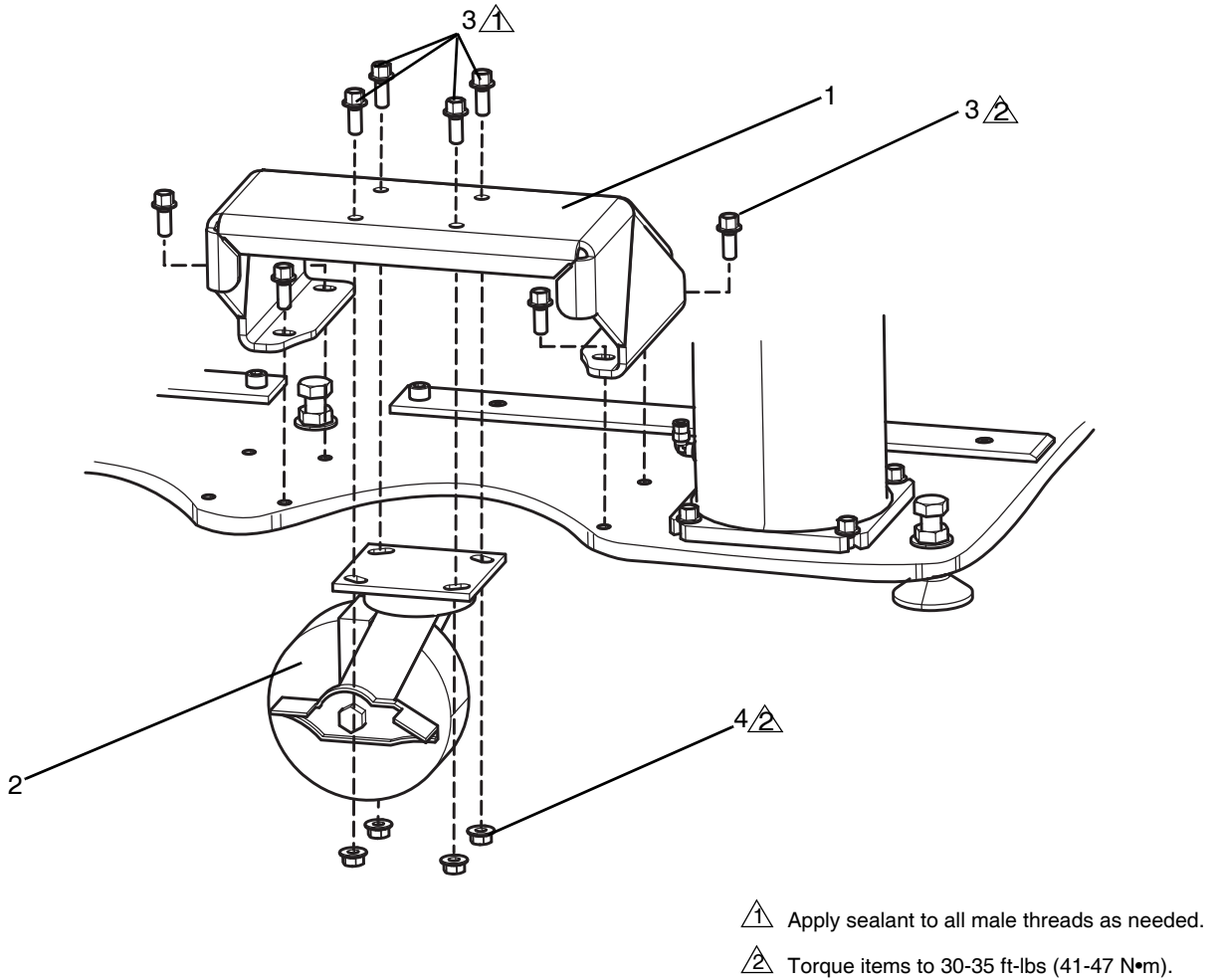

FIG. 1: Casters

Ref	Part	Description	Quantity
1	24X217	BRACKET, caster, white	4
2	121495	CASTER, swivel, w/brake, 800 lbs	4
3	127048	SCREW, machine, hex, flange, m10 x1.5 x 25	32
4	127076	NUT, hex, flange, serrated, m10	16

Dual Press Kit, 25A102

1. Apply tape to all male threads as needed.

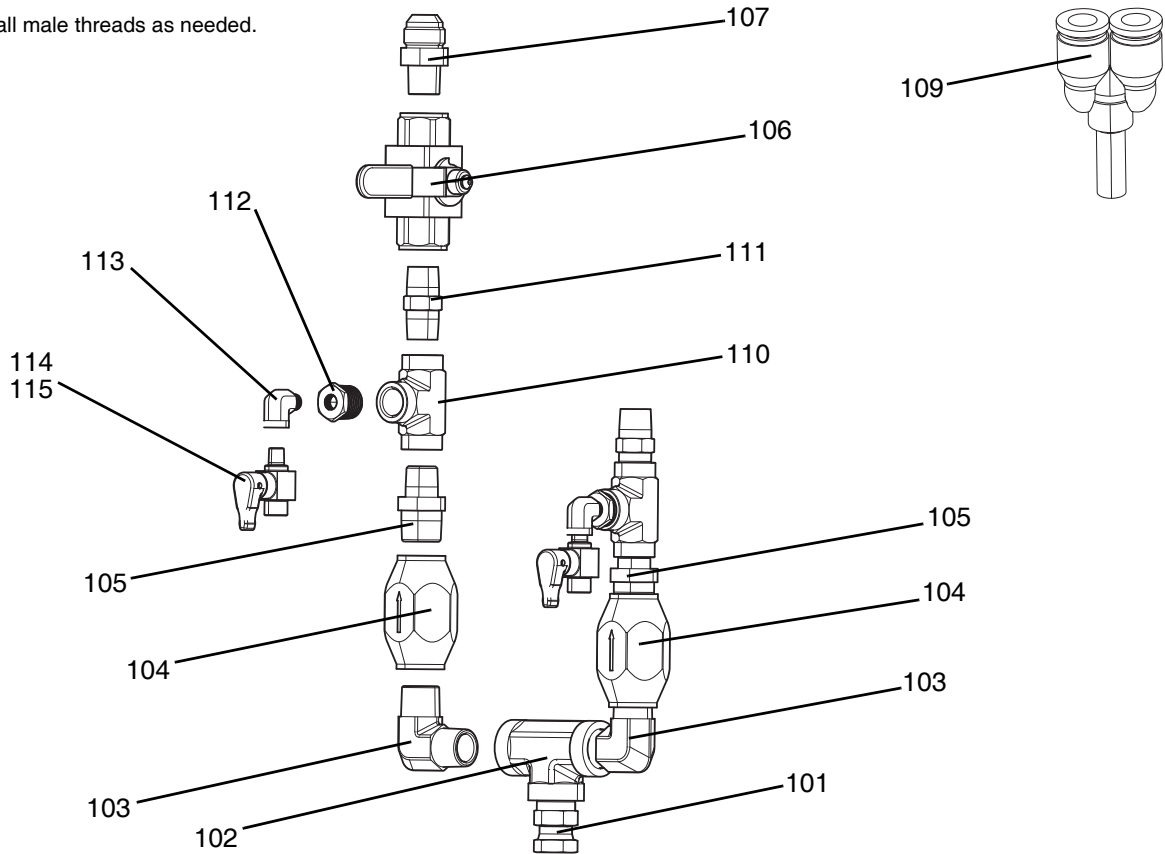

FIG. 2: Dual Press

Ref	Part	Description	Quantity
101	123980	FITTING, swivel, 3/4 x 1/2, mf, sst, 3.5	2
102	113833	TEE, pipe, female	2
103	15428-5-SS	FITTING, elbow, 90, 1/4 npt, mm, ss, 4k, 3	4
104	FAA081100	VALVE, check 3/4 npt, fxf, 4410 psi, ss	4
105	16R883	FITTING, nipple, reducing, 3/4 x 1/2	4
106	24P719	VALVE, 1/2 in. ball	2
107	94/1027/98	ADAPTER, jic 12 x 1/2 in. npt, mm, ss, 3k, 316	2
109	128058	FITTING, tee, 3/8 in. od, push	1
110	502570	FITTING, tee, 1/2 in. npt	4
111	114373	FITTING, nipple, 1/2 npt, sst hex	4
112	128055	FITTING, bushing, 1/2 npt x 1/8 npt, ss	4
113	128054	FITTING, elbow, st, 90, 1/8 npt, ss	4
114	256459*	KIT, A side valve (Red)	2
115	256460*	KIT, B side valve (Blue)	2

* Ensure you are using use the correct color-coded part for each side.

Second Press Cable Kit, 25A106

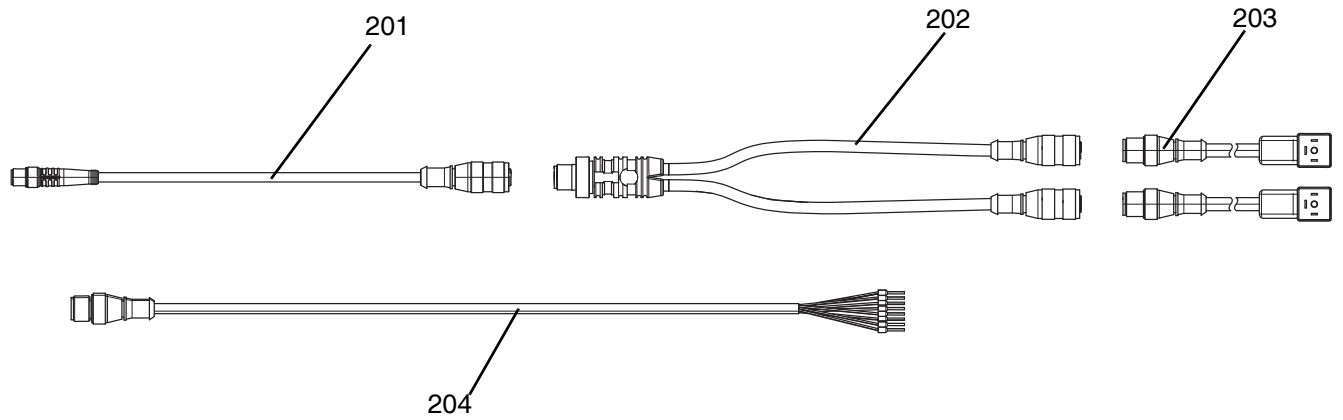
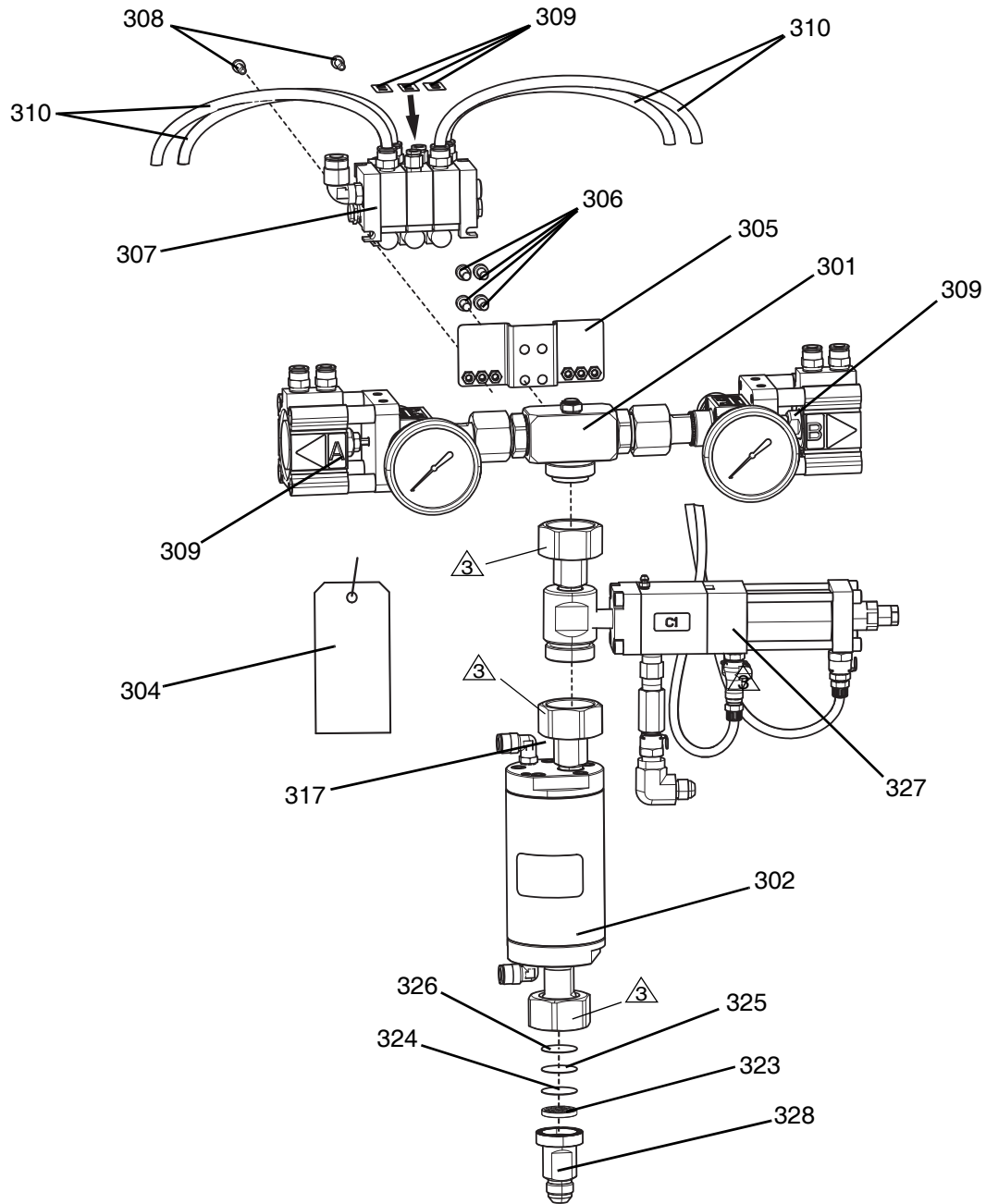

FIG. 3: Second Press Cable

Ref	Part	Description	Quantity
201	128197	CABLE, cga, m12, 5 pin, fxm 8, 4 pin, m	1
202	127949	HARNESS, splitter, m12	1
203	24M122	CORD, set, euro/male, din/female, rev	2
204	128441	CABLE, cga, m12, spin, m, 4m, pigtail	1

Straight Thread Multi-pass Mixing Stack, 25A990-993



 Torque items to 25-30 ft-lbs (30-40 N•m).

FIG. 4. Straight Thread Multi-pass Stack

Ref	Part	Description	Quantity	25A990	25A992	25A993
301	25B014*	MANIFOLD, assy, valve, 12 jic	1		✓	✓
	25A918*	MANIFOLD, assy, chck vlvs, 12 jic	1	✓		
302	25A876	MIXER, assy, 5 pass, sst	1	✓	✓	✓
304	172479▲	TAG, warning	1	✓	✓	✓
305	25A920	BRACKET, valve, stack, white	1		✓	✓
306	551295	SCREW, mach, pan hd	4		✓	✓
307	25B000	MANIFOLD, assy, stack, 2-valve	1		✓	
	25B001	MANIFOLD, assy, stack, 3-valve	1			✓
308	117126	SCREW, shcs m5 x16	2		✓	✓
309	17L943	LABEL, identification, stack	1		✓	✓
310	61/0027/88	TUBE, 0.313 od, polyflo, nat	3 ft		✓	✓
323	17L352	SUPPORT, screen, filter	1	✓	✓	✓
324	040768†	SCREEN, woven wire, 1 in. dia, 80 mesh	1	✓	✓	✓
325	040769†	SCREEN, woven wire, 1 in. dia, 100 mesh	1	✓	✓	✓
326	040770†	SCREEN, woven wire, 1 in. dia, 200 mesh	1	✓	✓	✓
327	25C478	KIT, color, injection	1			✓
328	17L384	FITTING, filter, 8 jic	1	✓	✓	✓

* Assembly 25B014 includes manifold 25A918. Mixing stack kit 25A990 uses only 25A918.

▲ Replacement Danger and Warning labels, tags, and cards are available at no cost.

† Parts are available in rebuild kit 25A915.

Straight Thread Single-pass Mixing Stack, 25A995-998

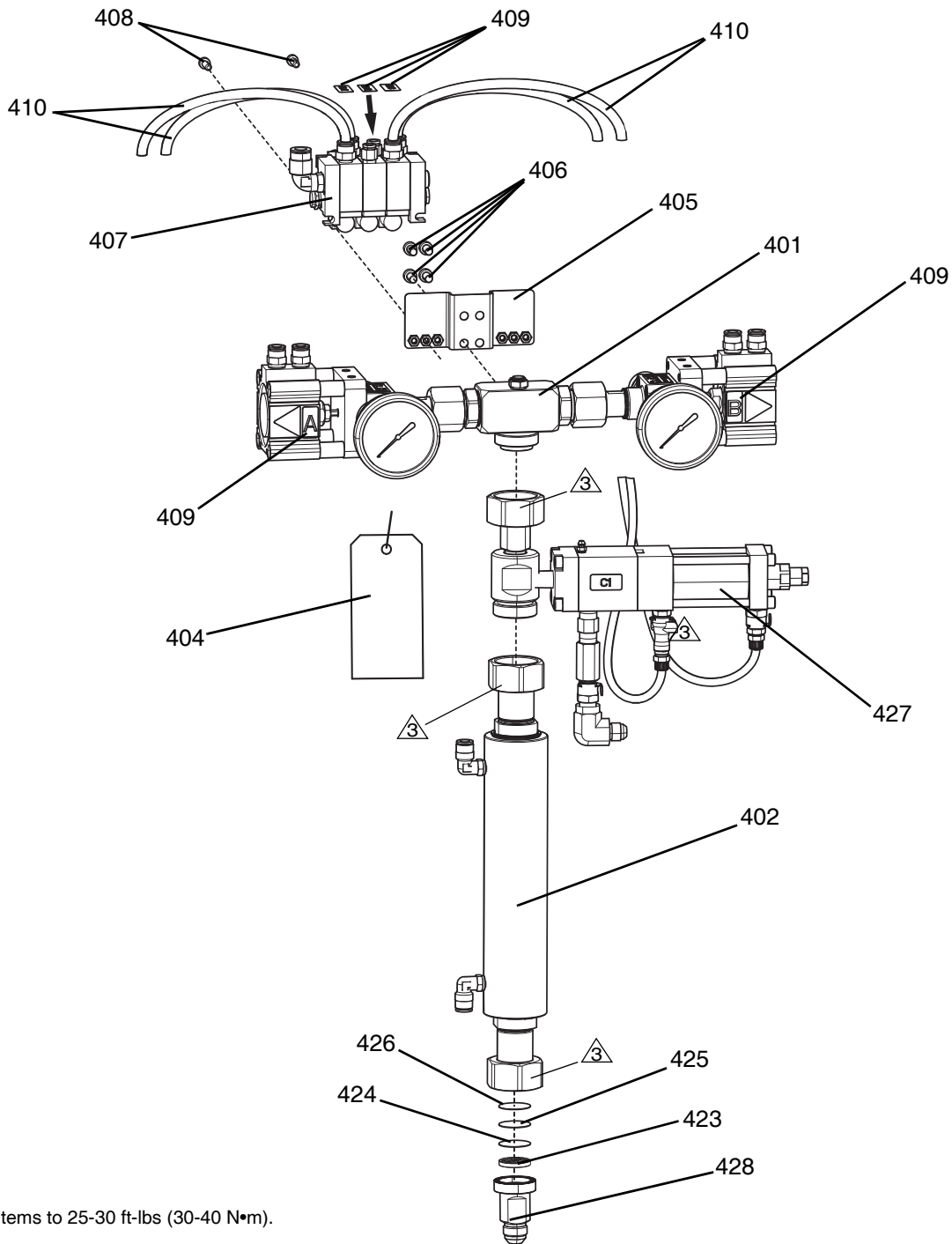

FIG. 5: Straight Thread Single-pass Stack

Ref	Part	Description	Quantity	25A995	25A997	25A998
401	25B014*	MANIFOLD, assy, valve, 12 jic	1		✓	✓
	25A918*	MANIFOLD, assy, chck vlvs, 12 jic	1	✓		
402	25C003	MIXER, assy, 12 element, sst, large	1	✓	✓	✓
404	172479▲	TAG, warning	1	✓	✓	✓
405	25A920	BRACKET, valve, stack, white	1		✓	✓
406	107530	SCREW, mach, pan, hd	4		✓	✓
407	25B000	MANIFOLD, assy, stack, 2-valve	1		✓	
	25B001	MANIFOLD, assy, stack, 3-valve	1			✓
408	117126	SCREW, shcs m5 x 16	2		✓	✓
409	17L943	LABEL, identification, stack	1		✓	✓
410	61/0027/88	TUBE, 0.313 od, polyflo, nat	3 ft		✓	✓
423	17L352	SUPPORT, screen, filter	1	✓	✓	✓
424	040768†	SCREEN, woven wire, 1 in. dia, 80 mesh	1	✓	✓	✓
425	040769†	SCREEN, woven wire, 1 in. dia, 100 mesh	1	✓	✓	✓
426	040770†	SCREEN, woven wire, 1 in. dia, 200 mesh	1	✓	✓	✓
427	25C478	KIT, color, injection	1			✓
428	17L384	FITTING, filter, 8 jic	1	✓	✓	✓

* Assembly 25B014 includes manifold 25A918. Mixing stack kit 25A995 uses only 25A918.

▲ Replacement Danger and Warning labels, tags, and cards are available at no cost.

† Parts are available in rebuild kit 25A915.

Multi-pass Stack Mixer, 25A876

For straight thread mixing stacks.

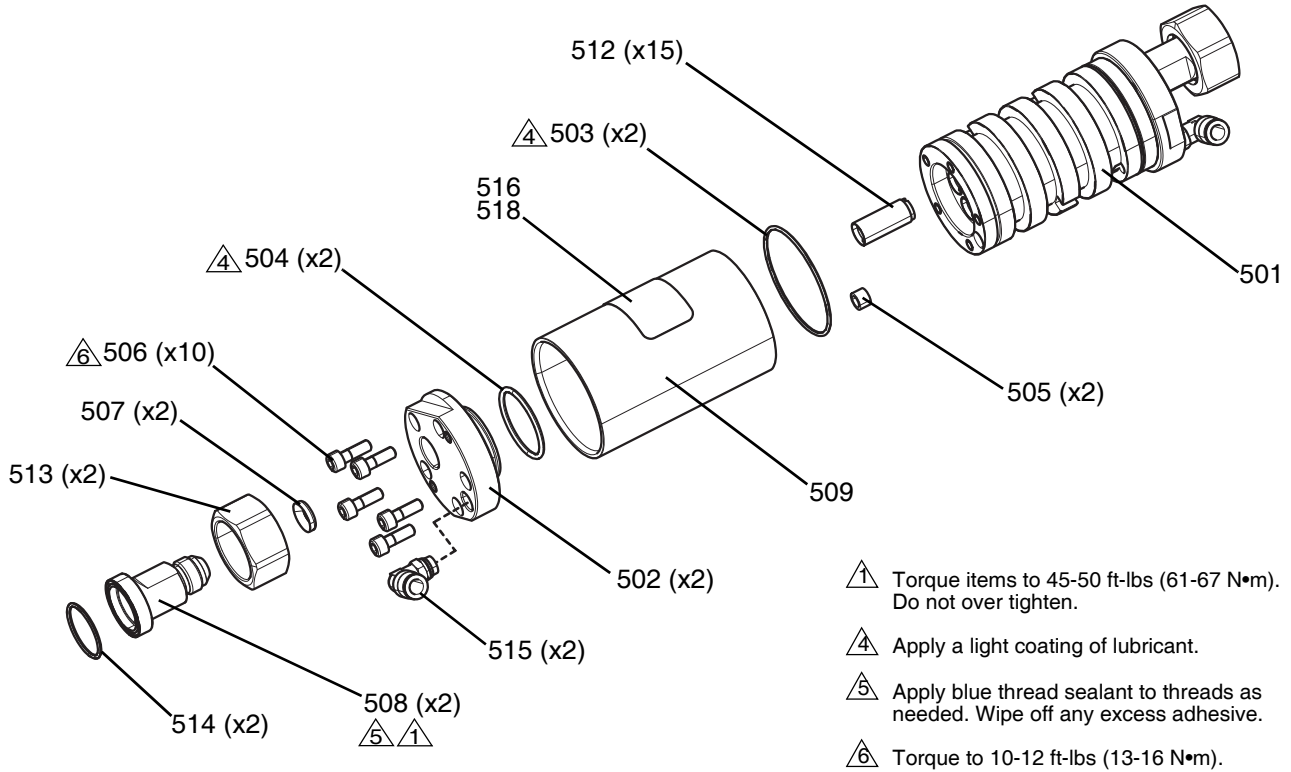

Fig. 6: Straight Thread Multi-pass Mixer

Ref	Part	Description	Quantity
501	17L156	HOUSING, mixer, 5 pass, sst, 1/2 in. bore	1
502	17L157	CAP, mixer, 5 pass, sst, 1/2 in. bore	2
503	C20272†	PACKING, o-ring	2
504	120901†	O-RING	2
505	17L339†	SEAL, .375 x .25o x .25 long	2
506	112556	SCREW, cap, sch	10
507	25B010†	SEAT, 8 jic	2
508	17L353	HOUSING, screen, filter, 8 jic	2
509	17L340	CYLINDER, water jacket, 2.5 x 4.23 lg	1
512	---	MIXER, cartridge	15
513	17L385	NUT, housing, filter	2
514	559013†	O-RING, (-024) fluoroelastomer-75 duro	2
515	116197	FITTING, elbow, 5/16 od x 1/8 nptf	2

--- Not available for individual sale.

† Parts are available in rebuild kit 25B005.

* Available in pack of 30 (part no. 25B003) or pack of 150 (part no. 25B004).

Single-pass Stack Mixer, 25C003

For straight thread mixing stacks.

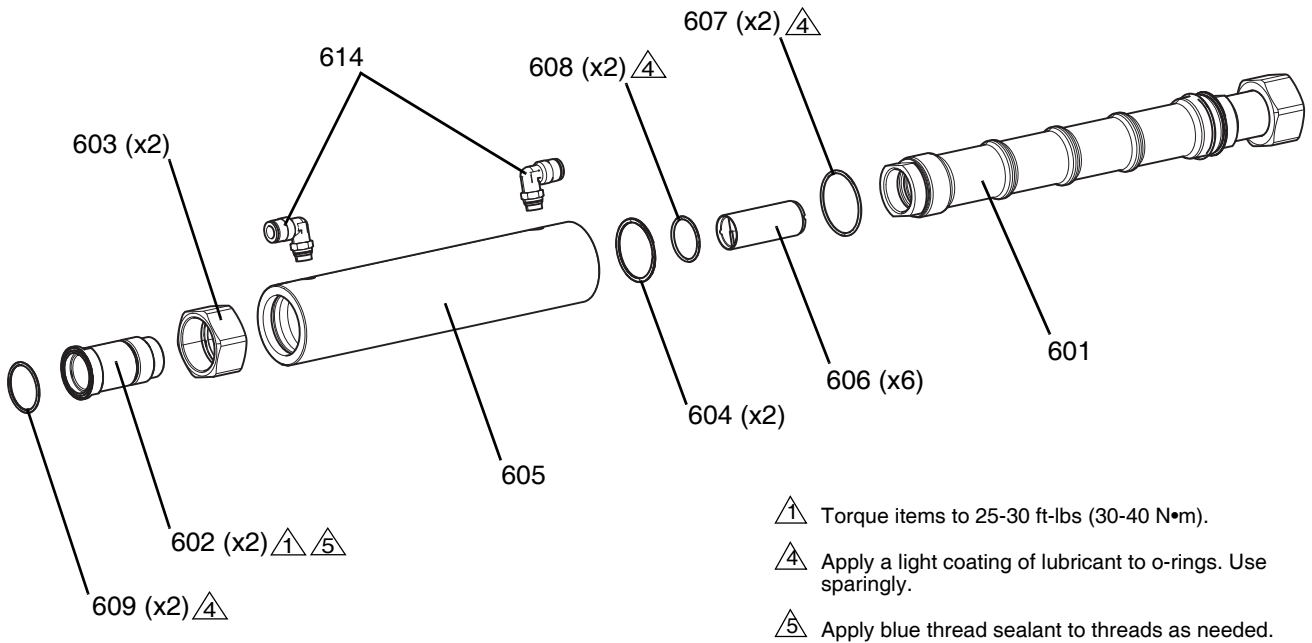

FIG. 7: Straight Thread Single-pass Mixer

Ref	Part	Description	Quantity
601	17L946	TUBE, mixer, sst, 12 element, lg	1
602	17L945	ADAPTER, flange to 1 1/8-16	2
603	17L385	NUT, housing, filter	2
604	129169	RING, retaining, od, 1.437	2
605	17L947	CYLINDER, water jacket	1
606	---	CARTRIDGE, mixer	6
607	122237†	PACKING, o-ring, 029, solvent resist	2
608	121370†	PACKING, o-ring 022	2
609	559013†	O-RING, (-024) fluoroelastomer-75 duro	2
614	116197	FITTING, elbow, 5/16 od x 1/8 nptf	2

--- Not available for individual sale.

† Parts are available in rebuild kit 25B008.

* Available in pack of 24 (part no. 25B006) or pack of 120 (part no. 25B007).

In-line Filter Replacement Kits

For straight thread mixing stacks.

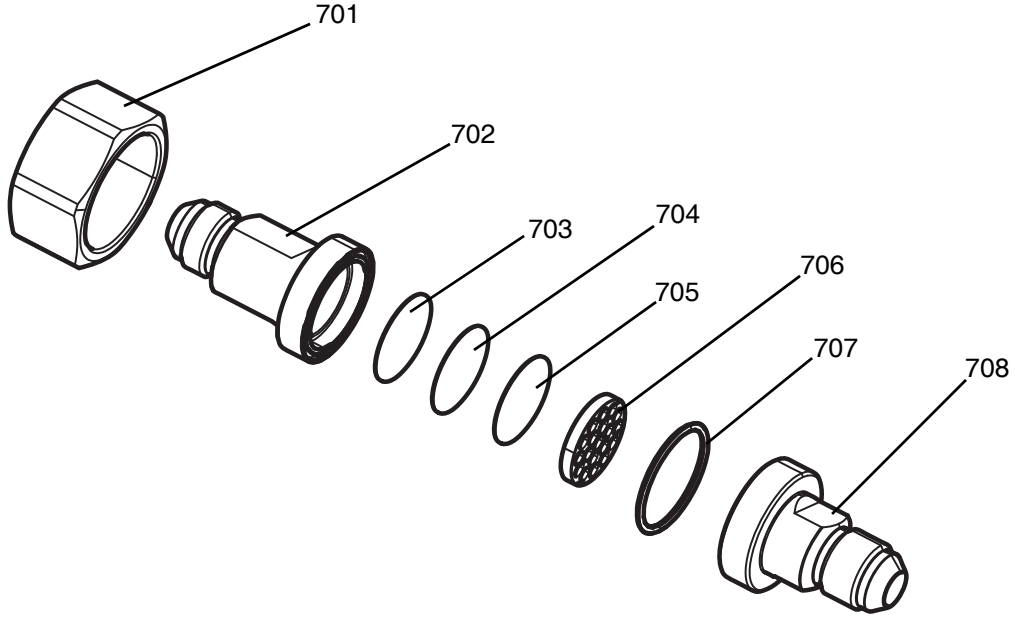

FIG. 8: In-line Filter Replacement Kits

Ref	Part	Description	Quantity	25A909	25A985	25A915
701	17L385	NUT, housing, filter	1	✓		
702	17L353	HOUSING, screen, filter, 8 jic	1	✓		
703	040770	SCREEN, woven wire, 1 in. dia, 200 mesh	1	✓	✓	✓
704	040769	SCREEN, woven wire, 1 in. dia, 100 mesh	1	✓	✓	✓
705	040768	SCREEN, woven wire, 1 in. dia, 80 mesh	1	✓	✓	✓
706	17L352	SUPPORT, screen, filter	1	✓	✓	
707	559013	O-RING, (-024) fluoroelastomer-75 duro	1	✓	✓	✓
708	17L384	FITTING, filter, 8 jic	1	✓		

--- Not available for individual sale.

Manifold Assembly, 25B014

For straight thread mixing stacks.

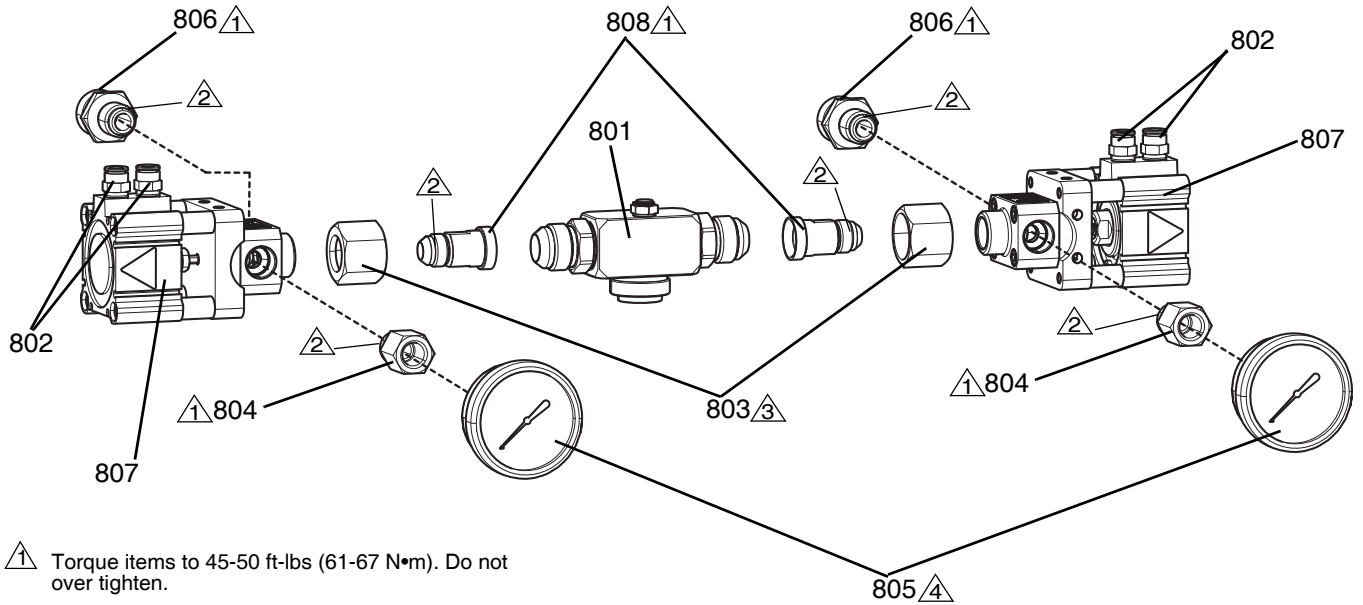

- 1 Torque items to 45-50 ft-lbs (61-67 N•m). Do not over tighten.
- 2 Apply blue thread sealant to threads as needed.
- 3 Torque items to 25-30 ft-lbs (30-40 N•m).
- 4 Apply ceramic tape to tapered male threads as

FIG. 9: Straight Thread Manifold Assembly

Ref	Part	Description	Quantity
801	25A918	MANIFOLD, assy, chck vlvs, 8 flange	1
802	129298	FITTING, connector, 1/4 bspt, 5/16 t	4
803	123129	NUT, tube, 3/4 jic	2
804	129134	ADAPTER, jic 8 x 1/4 npt, mxf, ss	2
805	113654	GAUGE, pressure, fluid, sst	2
806	129133	ADAPTER, jic 12 x jic 8, mxm, ss	2
807	24Z119	VALVE, 2-way, pneu, sst, 3k max	2
808	17L656	FITTING, adapter, 8 jic x 12 jic flange	2

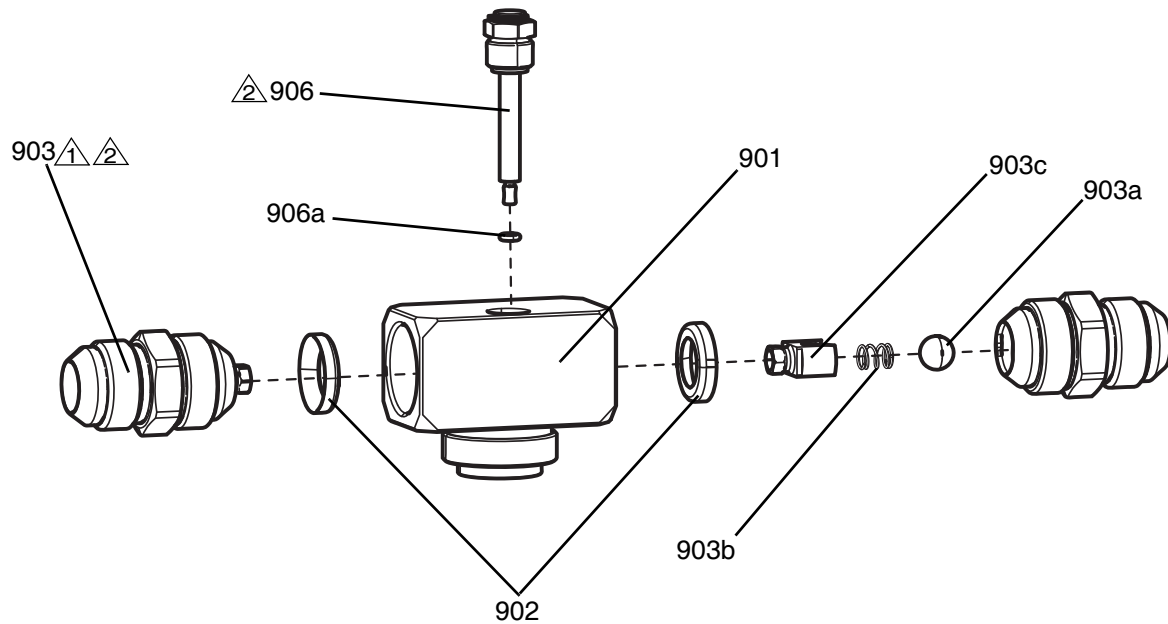
Manifold, 25A918**For straight thread mixing stacks.**

① Apply food grade lubricant to threads as needed and torque to 65-70 ft-lbs (88-95 N•m).

② Apply food grade lubricant to threads and o-ring and torque to 30-40 in-lb (3.5-4.5 N•m).

FIG. 10: Straight Thread Manifold

Ref	Part	Description	Quantity
901	17L430	MANIFOLD, sst, 12 jic to 1 3/8-20	1
902	25B012	SEAT, 10 jic	2
903	25A913	VALVE, check, 12 jic	2
903a	126959	BALL, ceramic, si-n	1
903b	121084	SPRING	1
903c	17L415	RETAINER, spring, check valve, 12 jic	1
906	25C012	PLUG, needle, injector, assy	1
906a	168518	PACKING, o-ring	1

Manifold On/Off Valves, 24Z119

For straight thread mixing stacks

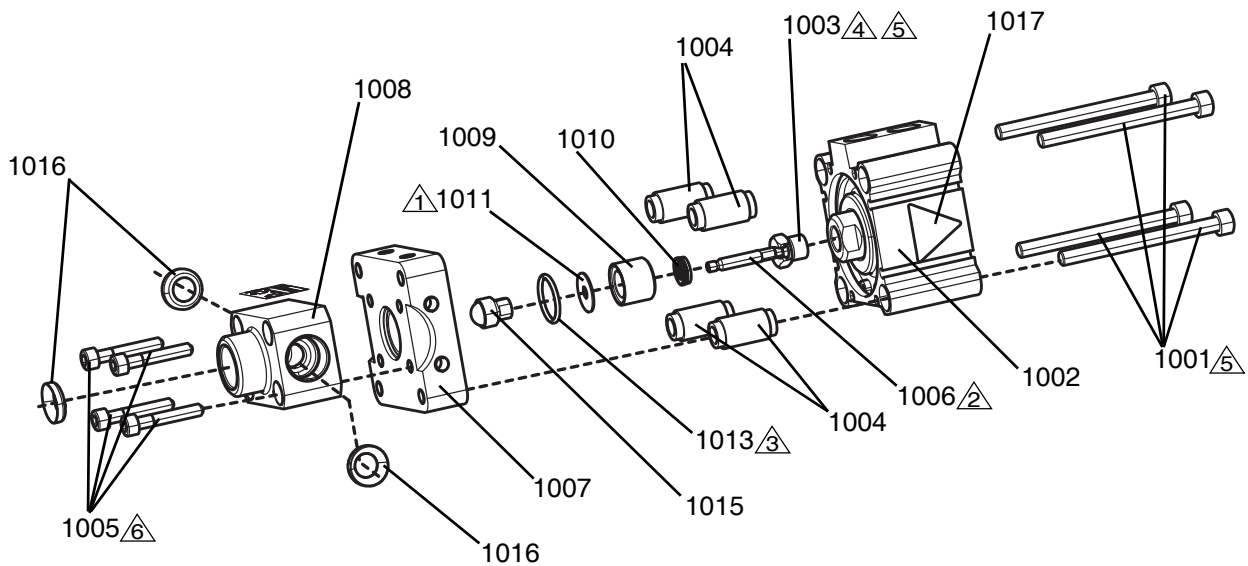

▲ Place seal into bearing with spring facing outward.

▲ Apply food grade lubricant to the chamber on shaft. Press shaft through bearing and seal using retainer to hold seal in place.

▲ Clean threads on shaft and tapped hole in ball holder. Apply blue thread sealant and torque to 41 in-lbs (4.6 N•m).

▲ Clean threads on coupling and tapped hole in air cylinder. Apply blue thread sealant. Tighten until seated.

▲ Torque to 140 in-lbs (16 N•m).

▲ Torque to 85 in-lbs (9.5 N•m).

FIG. 11: Straight Thread Manifold On/Off Valves

Ref.	Part	Description	Quantity
1001	117083	SCREW, shcs m6 x 70	4
1002	129040	CYLINDER, air, 50 mm bore, 5 mm stroke	1
1003	17L407	RETAINER, shaft, valve, shut-off ball	1
1004	17L391	SPACER, air cylinder	4
1005	121194	SCREW, shcs, m5 .8 x 30, ms	4
1006	17L406‡	SHAFT, valve, shut-off ball	1
1007	17L381	PLATE, valve, mounting	1
1008	25C005‡	BODY, valve, shut-off w/seat	1
1009	17L388‡	BEARING, valve shaft	1
1010	127734†	SEAL, double lip, pe, .187 x .437	1
1011	17L390	DISK, seal retainer	1
1013	106553†	PACKING, o-ring	1
1015	24Z118‡	BALL, socket assy, .406 dia	1
1016	25B010†	SEAT, 8 jic	3
1017	15H108▲	LABEL, safety, warning, pinch	2

▲ Replacement Danger and Warning labels, tags, and cards are available at no cost.

† Parts are available in repair kit 25B017.

‡ Parts are available in repair kit 25B015.

Stack Solenoid Blocks, 25B000 and 25B001
For straight thread mixing stacks.

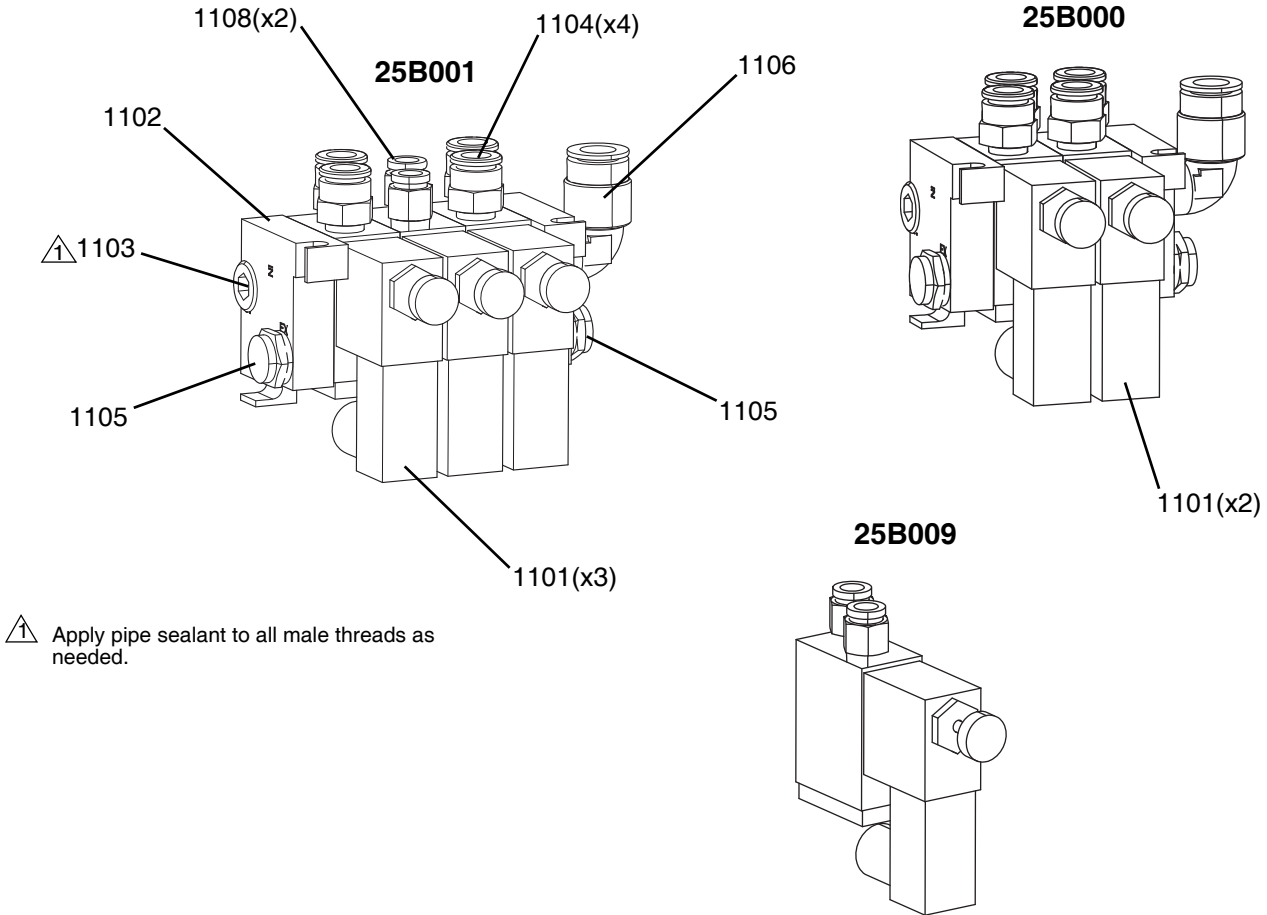

FIG. 12: Straight Thread Solenoid Blocks

Ref	Part	Description
1101	060247†	SOLENOID, pneumatic, 1/8 in. npt
1102	060255	PLATE, end, kit
1103	100721	PLUG, pipe
1104	129138	CONNECTOR, 1/8 npt x 5/16 tube, mxf, pltd
1105	121021	MUFFLER, 1/4 npt
1106	121018	FITTING, elbow, male, swivel, 1/4 npt
1107	070408	SEALANT, pipe, sst
1108	123371†	FITTING, connector, 1/4 tub x 1/8 npt, b

25B000 Quantity	25B001 Quantity
2	3
1	1
1	1
4	4
2	2
1	1
1	1
	2

† Parts are available in Solenoid Add-On Kit 25B009

Shut-off Valve, 25A987

For straight thread mixing stacks.

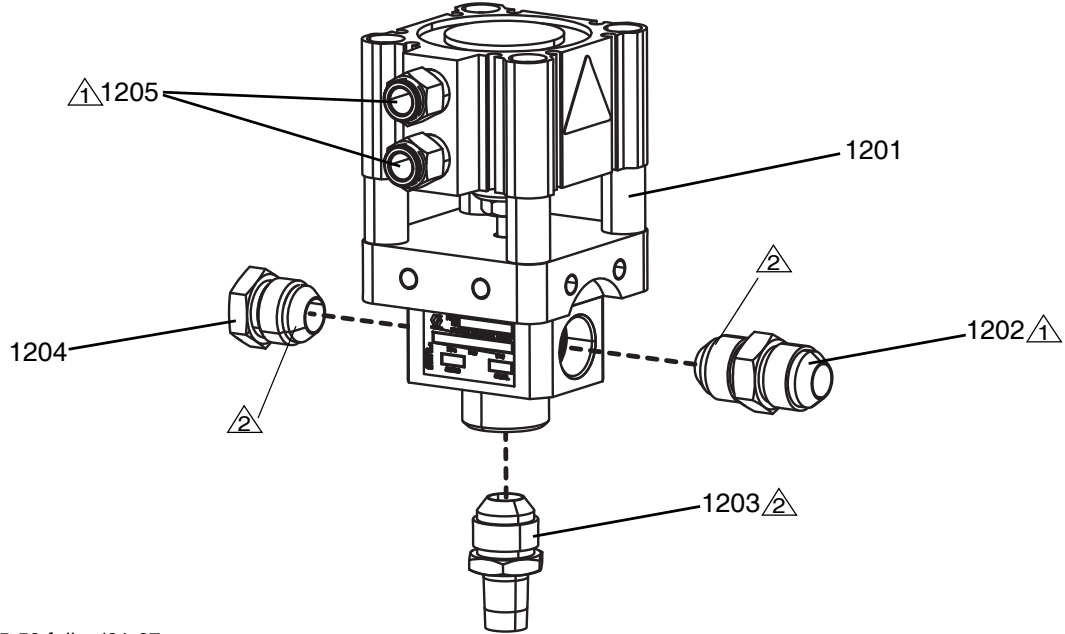

 Torque to 45-50 ft-lbs (61-67 N•m).

 Apply blue sealant to tapered threads as needed.

FIG. 13: Straight Thread Shut-off Valve

Ref	Part	Description	Quantity
1201	24Z119	VALVE, 2-way, pneu, sst, 3k max	1
1202	125781	FITTING, union, 8 jic x 8 jic, sst	1
1203	123598	ADAPTER, 8 jic x 1/4 in. npt	1
1204	129132	PLUG, hex, 8 jic, ss	1
1205	129298	CONNECTOR, 5/16 tube x r1/4, f x m, brs	2

Two-pass Mixer Assembly, 25B016

For straight thread mixing stacks.

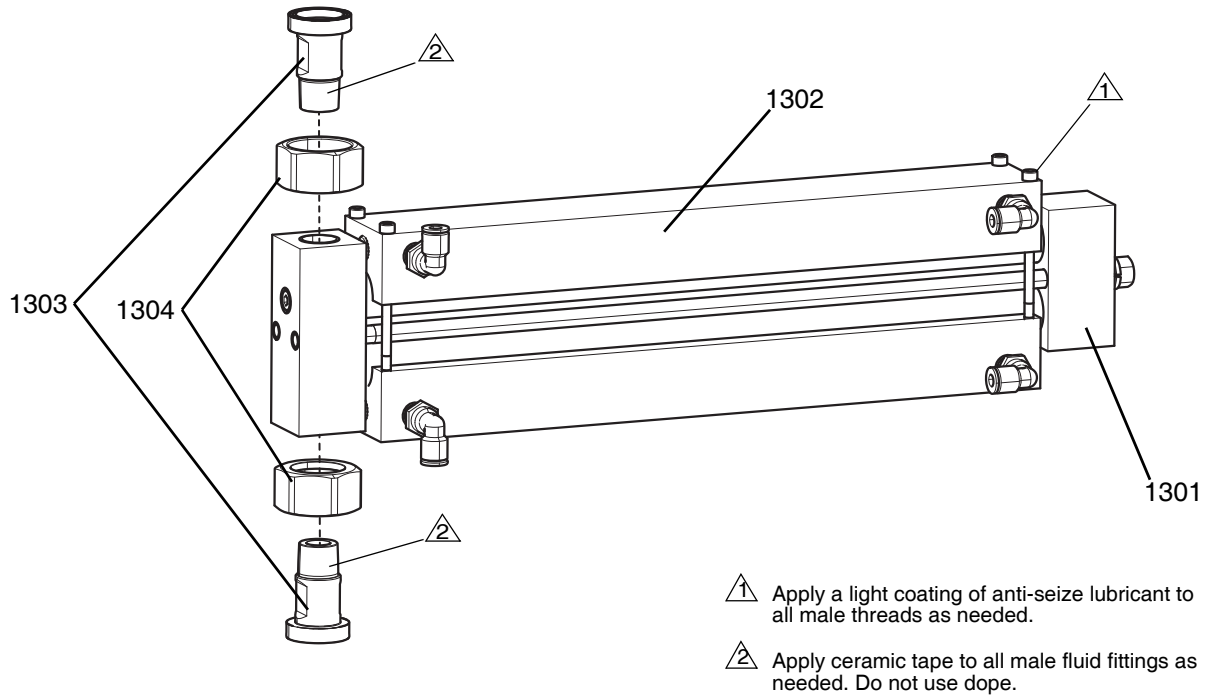

FIG. 14: Straight Thread Two-pass Mixer

Ref	Part	Description	Quantity
1301	SM396-324	MIXER, 2 pass, 16 cartridges, 1/4 np	1
1302	SK513	JACKET, water, 322, 324, 2 pass	1
1303	17L955	FITTING, adapter, 8 jic x 1/2 npt, m	2
1304	17L385	NUT, housing, filter	2

Material In-line Filter, 25A983

For straight thread mixing stacks

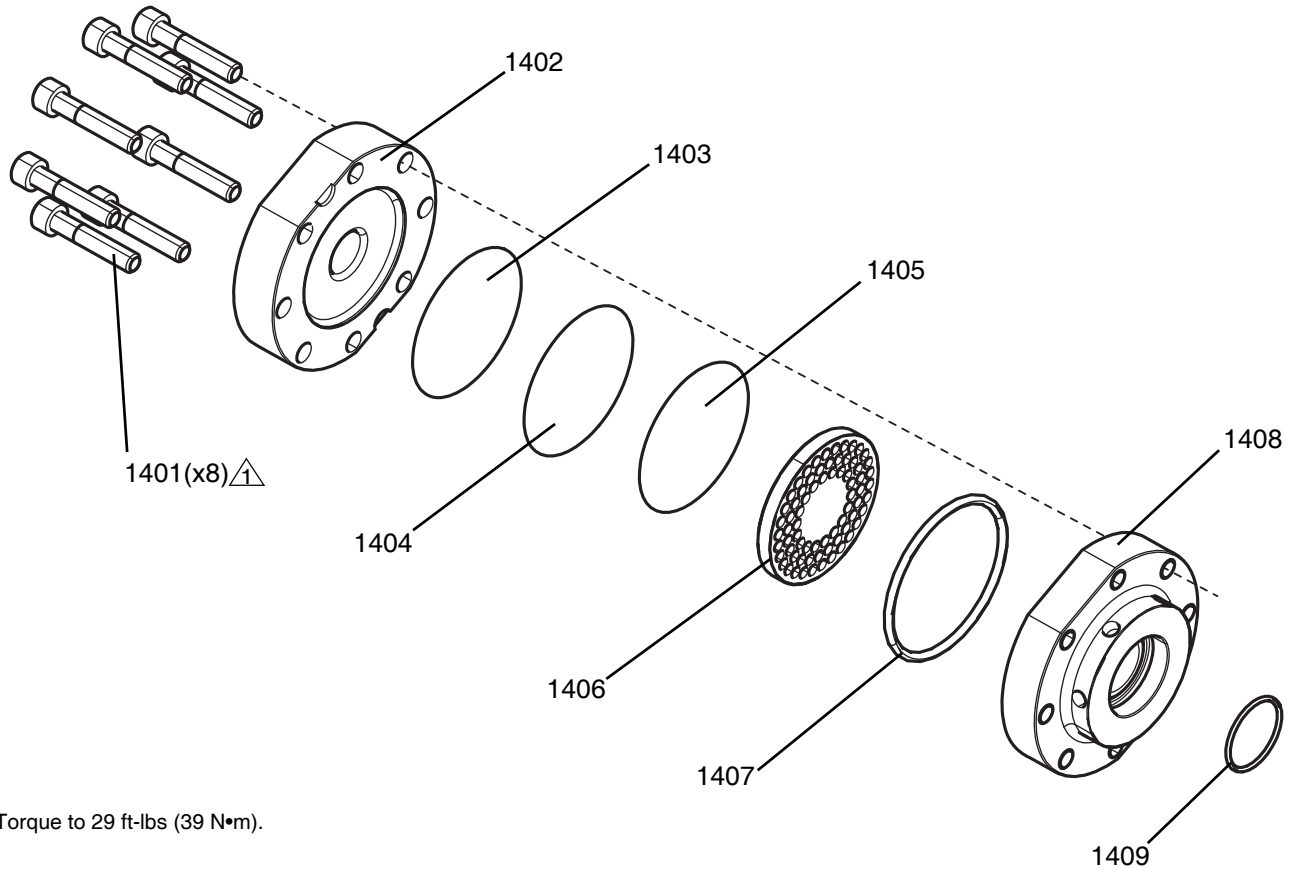

FIG. 15: Straight thread In-line Filter

Ref	Part	Description	Quantity
1401	121167	SCREW, shcs, m8 x 40	8
1402	17L792	CAP, inlet, 2.5 dia. filter	1
1403	FAA040512†	SCREEN, filter, 2.5 od, 80 mesh, sst	1
1404	FAA040513†	SCREEN, filter, 2.5 od, 100 mesh, sst	1
1405	FAA040514†	SCREEN, filter, 2.5 od, 200 mesh, sst	1
1406	17L940	SUPPORT, filter, 2.5 in. dia, 303 ss	1
1407	109458†	PACKING, o-ring	1
1408	17L793	CAP, outlet, 2.5 dia. filter	1
1409	108526†	PACKING, o-ring, ptfe	1
1410	112887✿	TOOL, wrench, spanner	1

✿ Not shown.

† Parts are available in repair kit 25B018.

Material Regulator, 25A892 and 25A899

For straight thread mixing stacks.

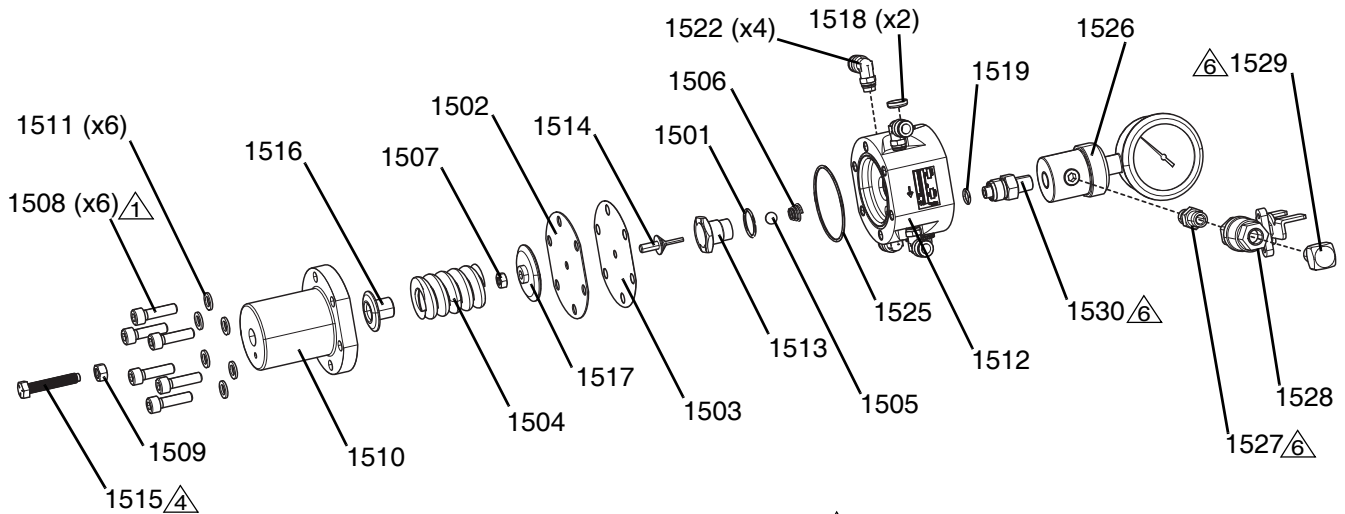

▲1 Torque to 28-30 ft-lbs (38-40 N•m). Tightening sequence should be in a star pattern.

▲4 Apply a light coating lubricant to spherical end as needed.

▲6 Apply tape to all male NPT threads as needed.

Fig. 16: Straight Thread Material Regulators

Ref	Part	Description	25A899 With Gauge	25A892 Without Gauge
1501	C38312‡	O-RING, -019 fluoroelastomer a 75 duro	1	1
1502	---†	DIAPHRAGM, regulator, polypropylene	1	1
1503	---†	DIAPHRAGM, regulator, ptfе	1	1
1504	FAA040308	SPRING,COMP, 1.43 od x 2.13 lg, 7, 921	1	1
1505	FAA040309‡	BALL, 11/32 dia, tc, gr 25, 92 rc	1	1
1506	FAA040310‡	SPRING, comp, conical, sa921	1	1
1507	FAA040480	NUT, nlock, hex, 1/4-28, gr 2, zin	1	1
1508	109114	SCREW, cap, sch	6	6
1509	FAA040484	NUT, jam, hex, 5/16-24, gr 5, zink	1	1
1510	25A911	COVER, assy, regulator	1	1
1511	108788	WASHER, m8	6	6
1512	17L382	HOUSING, regulator	1	1
1513	SA920005‡	VALVE, assy, retainer, seat	1	1
1514	SA920006‡	SCREW, stem, valve, cs, chrome	1	1
1515	SA920007	SCREW, hhc, 5/16-24 x 1.88, cs, cust	1	1
1516	SA920008	CAP, retainer/guide, spring, cs	1	1
1517	SA921005	PLATE, oscillator, spring, cs, zink	1	1

1518	25B010	SEAT, 8 jic	2	2
1519	121399	PACKING, o-ring 012 f x 75	1	1
1522	116197	FITTING, elbow, 5/16 od x 1/8 nptf	4	4
1525	C20272†	PACKING, o-ring	1	1
1526	080690	GAUGE, press, 0-1k psi, 1/4 nptm, bm	1	
1527	121907	FITTING, nipple, hex, 1/4 npt, sst, swv	1	
1528	080803	VALVE, ball, 1/4 in. f, 2k psi, 316 ss	1	
1529	166866	FITTING, elbow, street	1	
1530	17L895	ADAPTER, regulator, gauge	1	
	15K815	PLUG, dummy, transducer		1

--- Not available for individual sale.

† Parts are available in kit 25A914.

‡ Parts are available in repair kit 25B013.

Color Injector, 25C478

For straight thread mixing

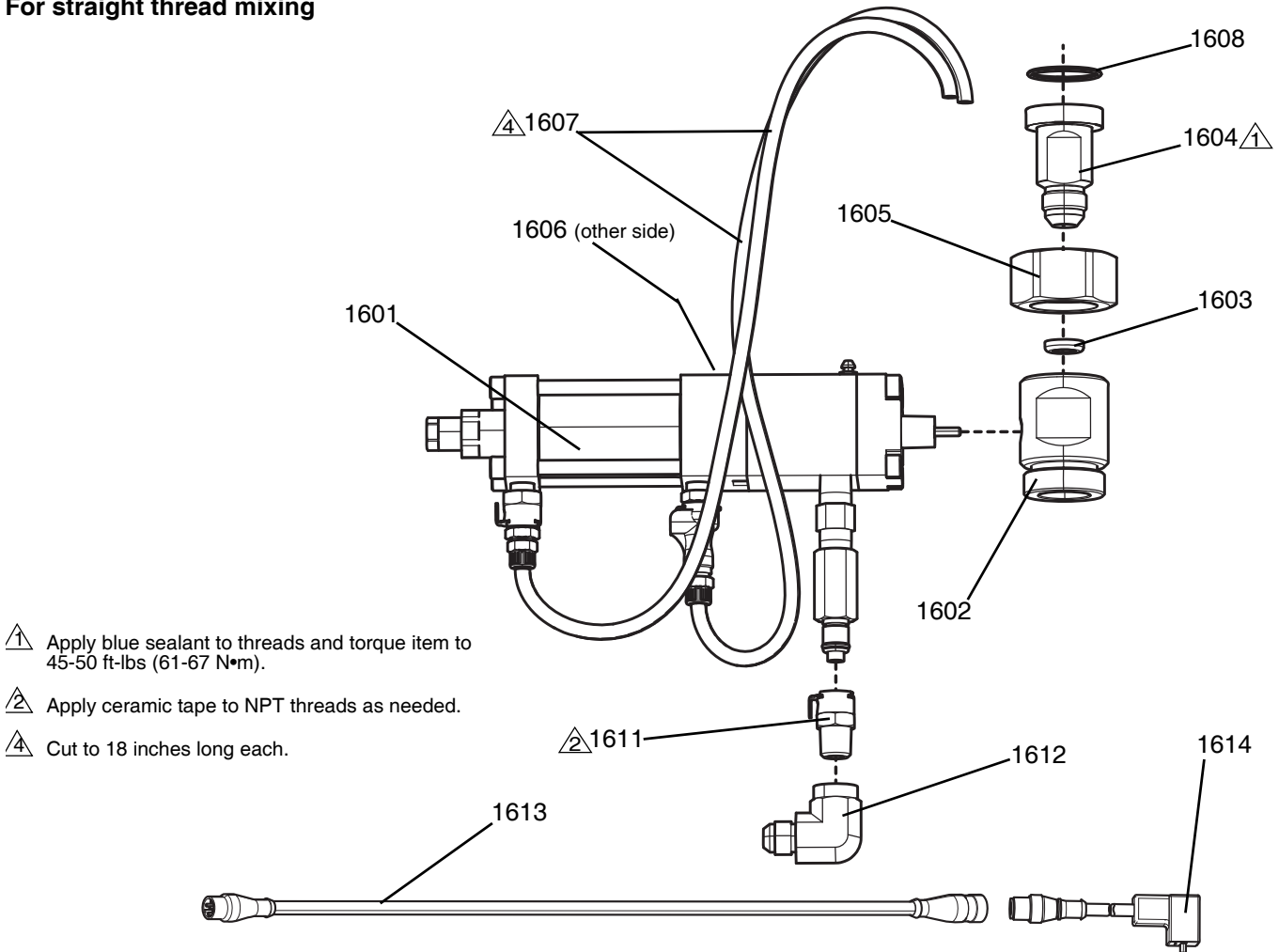

△ Apply blue sealant to threads and torque item to 45-50 ft-lbs (61-67 N•m).

△ Apply ceramic tape to NPT threads as needed.

△ Cut to 18 inches long each.

FIG. 17: Straight Thread Color Injector

Ref	Part	Description	Quantity
1601	SN751-1A	INJECTOR, assy, color	1
1602	17M441	ADAPTER, 1-3/8 in. x jic 8	1
1603	25B010	SEAT, 8 jic	1
1604	17L353	HOUSING, screen, filter, 8 jic	1
1605	17L385	NUT, housing, filter	1
1606	17L943	LABEL, identification, stack	1
1607	61/0001/88	TUBE, 250 od, poly	3
1608	559013	O-RING, (-024) fluoroelastomer-75 duro	1
1611	081076	HOUSING, body, qd, 1/4 nptm, crplt, brs	1
1612	080071	FITTING, elbow, 90, jic 6 x 1/4 npt, mf	1
1613	24E899	CABLE, 5 pin, mf, 4.0, molded	1
1614	125750	CORD SET, euro/male, din/female, rev	1

Mini Single-pass Mixing Stack, 25C794/99

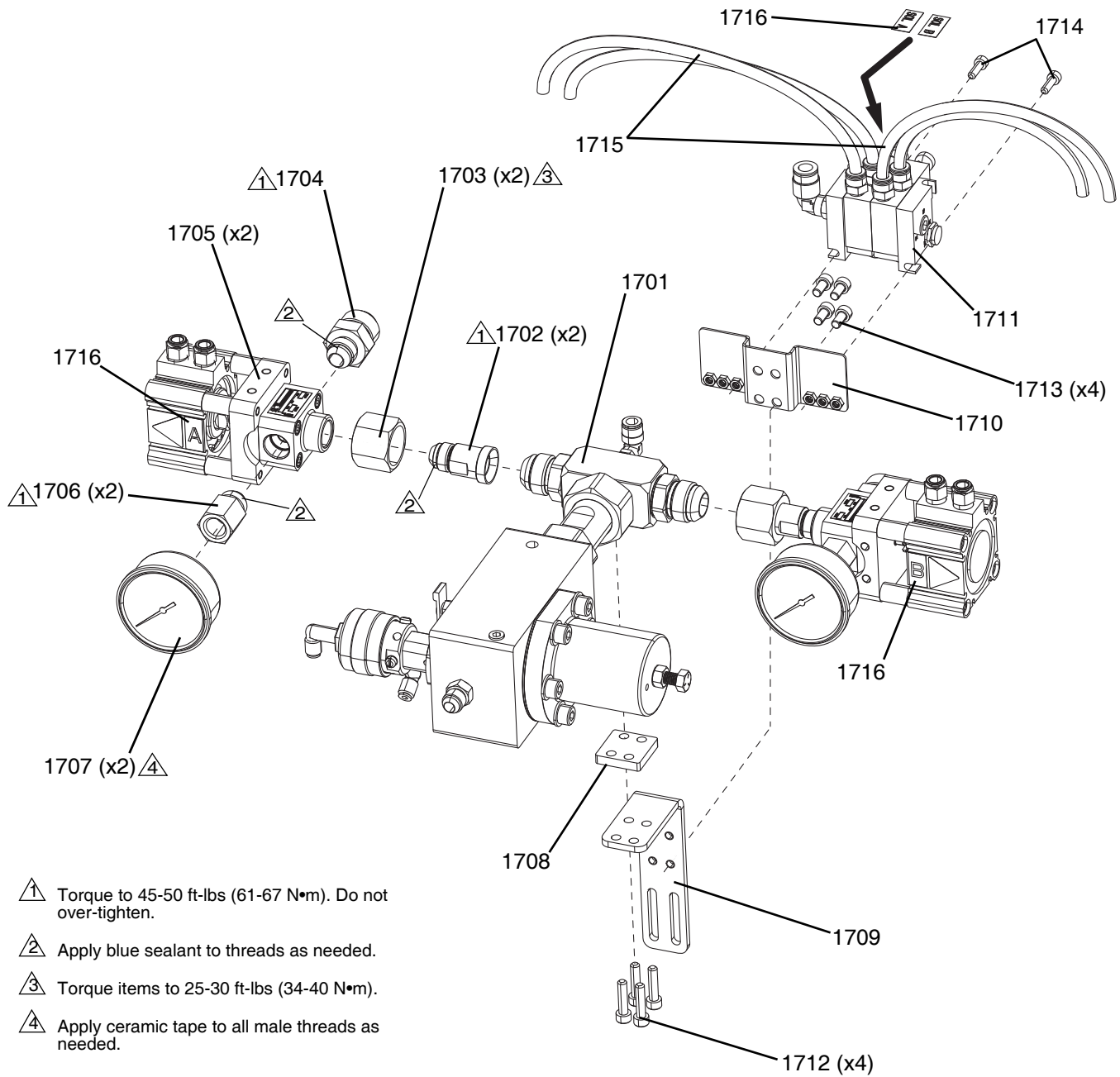

FIG. 18: Mini Single-pass Stack Mini-shots

Ref	Part	Description	Quantity	25C794	25C799
1701	25C792	REGULATOR, chilled, w/shut off valve	1	✓	
	25C793	REGULATOR, chilled, w/o shut off valve	1		✓
1702	17L656	FITTING, adapter, 8 jic x 12 jic flange	2	✓	✓
1703	123129	NUT, tube, 3/4 jic	2	✓	✓
1704	129133	ADAPTER, jic (12) x jic (08), mxm, ss	2	✓	✓
1705	24Z119	VALVE, 2-way, pneu, sst, 3k max	2	✓	✓
1706	129134	ADAPTER, jic (08) x 1/4 pt, mxf, ss	2	✓	✓
1707	080103	GAUGE, 5000, psi, liquid, 2.5 in.	2	✓	✓
1708	17S280	INSULATOR, valve	1	✓	✓
1709	25C797	BRACKET, valve, white	1	✓	✓
1710	25A920	BRACKET, valve, stack, white	1	✓	✓
1711	25B000	MANIFOLD, assy, stack, 2-valve	1	✓	✓
1712	117029	SCREW, shcs m6 x 25	4	✓	✓
1713	107530	SCREW, cap, sch, hex	4	✓	✓
1714	117126	SCREW, shcs m5 x 16	2	✓	✓
1715	61/0027/88	TUBE, 0.313 od, polyflo, nat	4 ft	✓	✓
1716	17L943	LABEL, identification, stack	1	✓	✓

Mixer-Material Regulator Component, 25C792/93

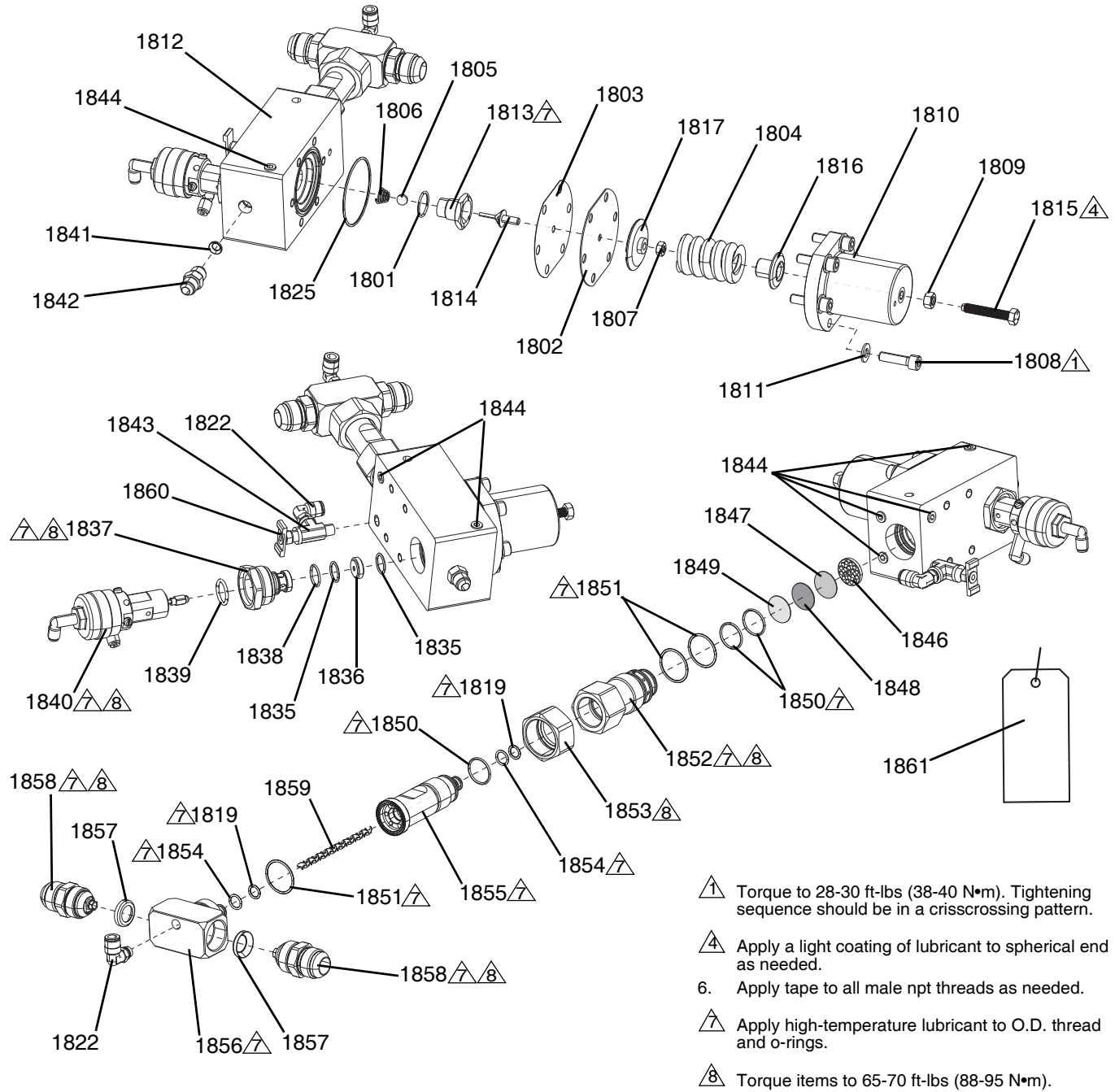

FIG. 19: Mixer-Material Regulator

Ref	Part	Description	Quantity	25C792	25C793
1801	C38312	O-RING, -019 fluoroelastomer a 75 duro	1	✓	✓
1802	---†	DIAPHRAGM, regulator, polypropylene	1	✓	✓
1803	---†	DIAPHRAGM, regulator, ptfe	1	✓	✓
1804	FAA040308	SPRING, comp, 1.43 od x 2.13 lg, 7, 921	1	✓	✓
1805	15W305	BALL, carbide, 25 cc, 50 cc	1	✓	✓
1806	FAA040310	SPRING, comp, conical, sa921	1	✓	✓
1807	FAA040480	NUT, nlock, hex, 1/4-28, gr 2, zin	1	✓	✓
1808	109114	SCREW, cap, sch	6	✓	✓
1809	FAA040484	NUT, jam, hex, 5/16-24, gr 5, zink	1	✓	✓
1810	25A911	COVER, assy, regulator	1	✓	✓
1811	108788	WASHER, flat	6	✓	✓
1812	17S224	HOUSING, regulator, w/valve, sst	1	✓	✓
1813	SA920005	VALVE, assy, retainer, seat	1	✓	✓
1814	SA920006	SCREW, stem, valve, cs, chrome	1	✓	✓
1815	SA920007	SCREW, hhc, 5/16-24 x 1.88, cs, cust	1	✓	✓
1816	SA920008	CAP, retainer/guide, spring, cs	1	✓	✓
1817	SA921005	PLATE, oscillator, spring, cs, zink	1	✓	✓
1819	556555	O-RING, -012 fluoroelastomer-a 75 duro	2	✓	✓
1822	116197	FITTING, elbow, 5/16 od x 1/8 nptf	2	✓	✓
1825	C20272†	PACKING, o-ring	1	✓	✓
1835	109450	PACKING, o-ring	2	✓	✓
1836	15U932	SEAT, valve needle, high press	1	✓	✓
1837	17S226	RETAINER, seat, valve	1	✓	
	17S227	RETAINER, seat, no valve	1		✓
1838	106553	PACKING, o-ring	1	✓	
1839	15Y627	PACKING, o-ring #2-116, ptfe	1	✓	
1840	256210	VALVE, dispense, hp	1	✓	✓
1841	25D114	SEAT, 6 jic	1	✓	✓
1842	125779	FITTING, union, 06 jic x 06 jic, sst	1	✓	✓
1843	110475	FITTING, street, tee	1	✓	✓
1844	110208	PLUG, pipe, headless	5	✓	✓
1846	17L352	SUPPORT, screen, filter	1	✓	✓
1847	040768‡	SCREEN, woven wire, 1 in. dia, 80 mesh	1	✓	✓
1848	040769‡	SCREEN, woven wire, 1 in. dia, 100 mesh	1	✓	✓
1849	040770‡	SCREEN, woven wire, 1 in. dia, 200 mesh	1	✓	✓
1850	103413	PACKING, o-ring	3	✓	✓
1851	559013‡	O-RING, (-024) fluoroelastomer-75 duro	3	✓	✓
1852	17S230	ADAPTER, mixer, regualtor	1	✓	✓
1853	17L385	NUT, housing, filter	1	✓	✓
1854	GC2057	O-RING, o-ring, fluoroelastomer, 2-013	2	✓	✓
1855	17S228	TUBE, plastic mixer, 12 x .25 dia	1	✓	✓
1856	17S225	HOUSING, adapter, mixer	1	✓	✓

Ref	Part	Description
1857	25B012	SEAT, 12 jic
1858	25A913	VALVE, check, 12 jic
1859	512532	ELEMENT, mixer static
1860	517269	VALVE, drain cock
1861	172479▲	TAG, warning

Quantity	25C792	25C793
2	✓	✓
2	✓	✓
1	✓	✓
1	✓	✓
1	✓	✓

--- Not available for individual sale.

▲ Replacement Danger and Warning labels, tags, and cards are available at no cost.

† Parts are available in kit 25A914.

‡ Parts are available in rebuild kit 25A915.

Stack Bracket Kit, 25C998

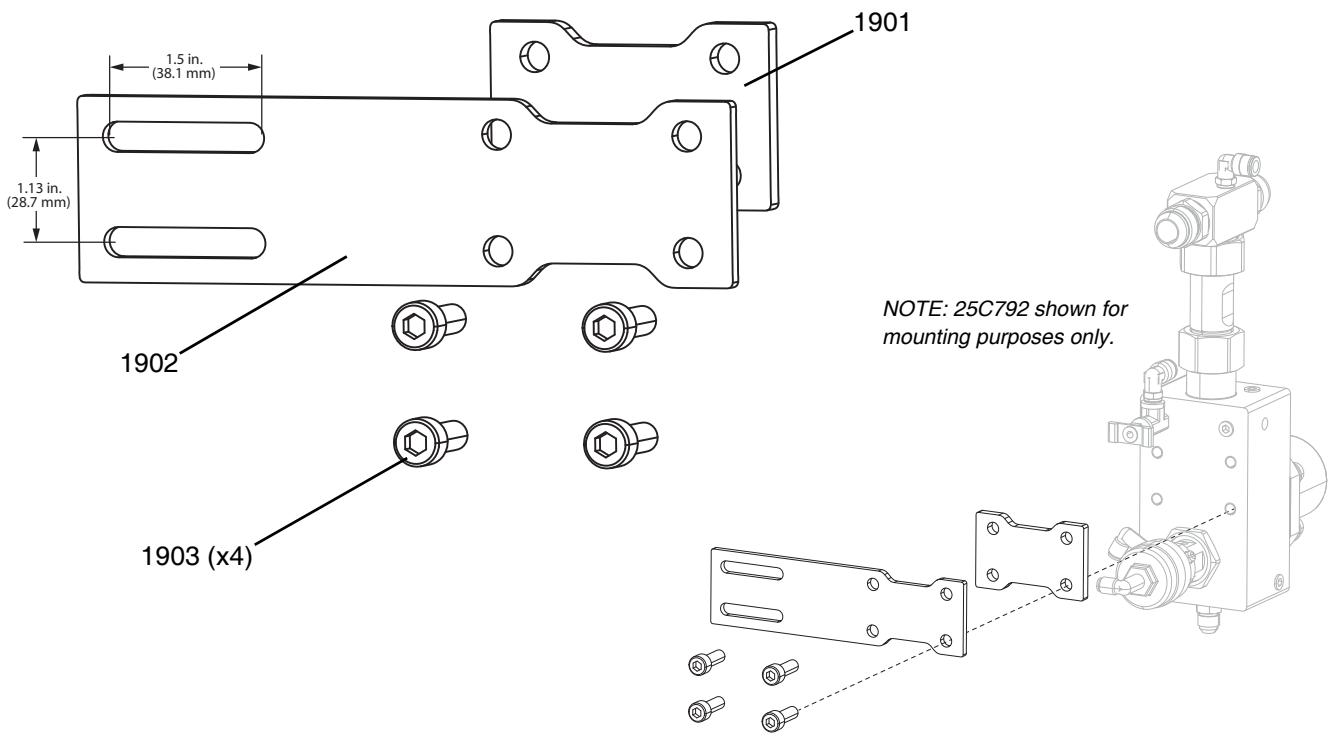
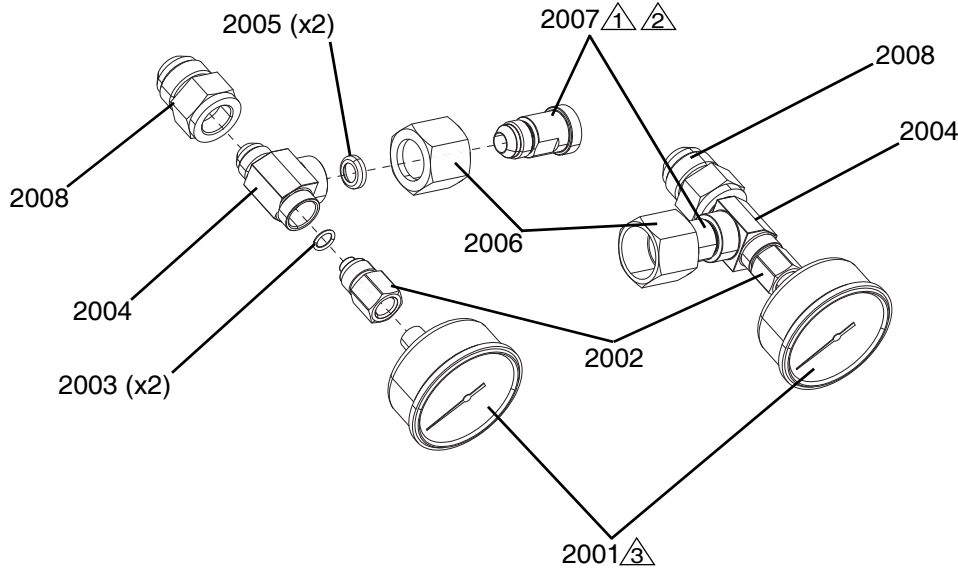

FIG. 20: Stack Bracket Kit

Ref	Part	Description	Quantity
1901	17S279	INSULATOR, regulator	1
1902	25C796	BRACKET, regulator, white	1
1903	120913	SCREW	4

Stack Adapter Kit, 25D011





-  Torque to 45-50 ft-lbs (61-67 N•m). Do not over-tighten.
-  Apply blue sealant to threads as needed.
-  Apply ceramic tape to all male

FIG. 21: Stack Adapter Kit

Ref	Part	Description	Quantity
2001	080103	GAUGE, 5000, psi, liquid, 2.5 in.	2
2002	17T095	FITTING, adapter	2
2003	111457	PACKING, o-ring	2
2004	17T096	FITTING, adapter	2
2005	25B010	SEAT, 8 jic	2
2006	123129	NUT, tube, 3/4 jic	2
2007	17L656	FITTING, adapter, 8 jic x 12 jic flange	2
2008	17T211	FITTING, reducer, 08 jic x 12 jic, fxm, s	2

JIC Adapters (Sold Individually)

Part	Description	Image
17T211	FITTING, reducer, 08 jic x 12 jic, fxm, s	
125781	FITTING, union, 08 jic x 08 jic, sst	
128442	FITTING, adapter, 12 jic x 08 jic, fm, ss	

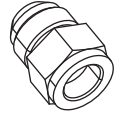
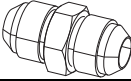
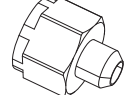
Tapered Thread Mixing Stack, 24R681

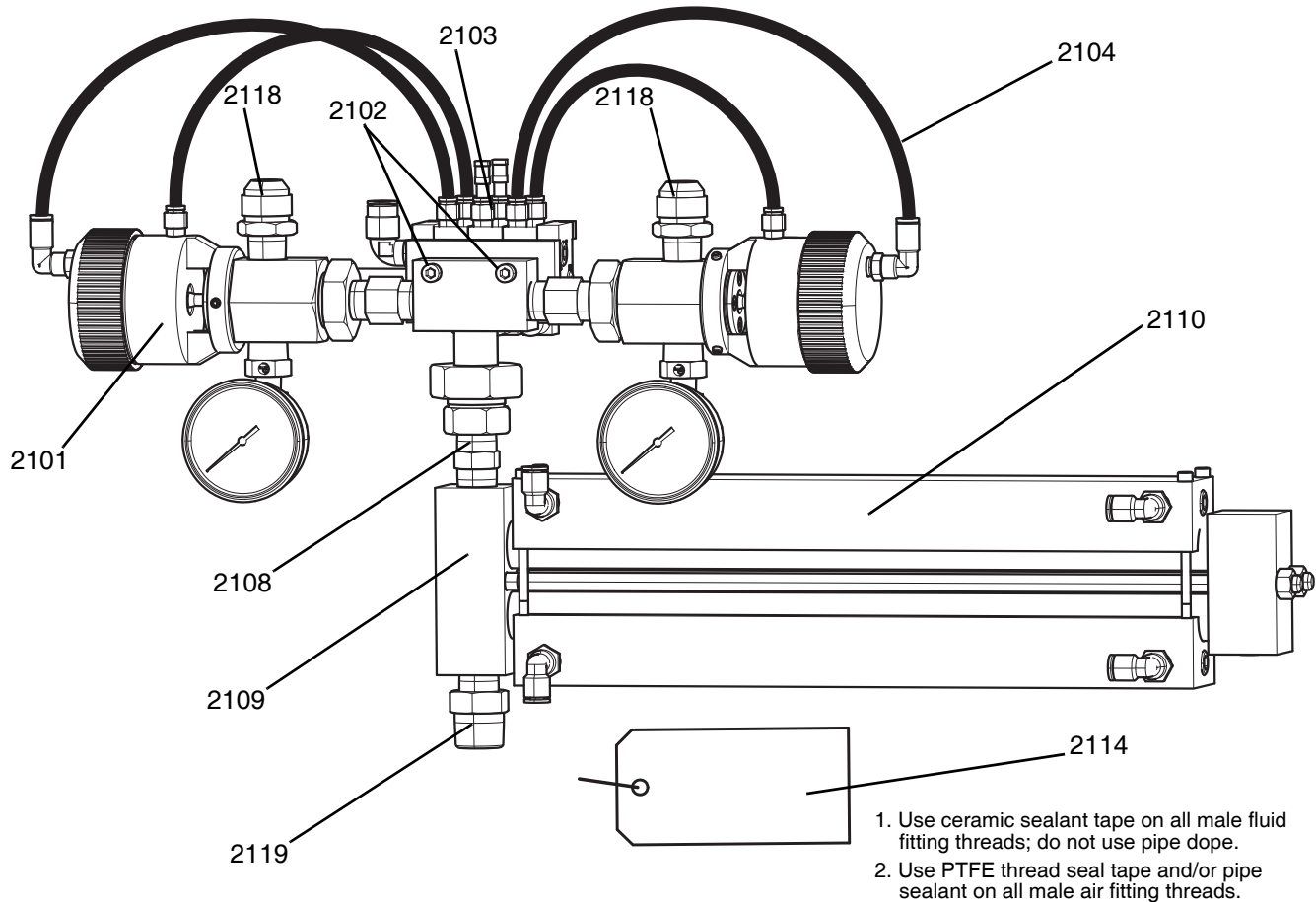

FIG. 22: Tapered Thread Stack 24R681

Ref	Part	Description	Quantity
2101	SA914-5A	MANIFOLD, mixer, assy, gun, 1/2 npt	1
2102	96/0105/99	SCREW, shc, 1/4-20 x 1.50, ms, e	2
2103	SK579	MANIFOLD, pneumatic, 3-solenoid, rh	1
2104	61/0001/88	TUBE, 1/4 in. od, poly	4.7 ft
2108	114373	FITTING, nipple, 1/2 npt, sst hex	1
2109	SM396-324	MIXER, 2 pass, 16 cartridges, 1/4 npt	1
2110	SK513	JACKET, water, 322, 324, 2 pass	1
2114	172479▲	TAG, warning	1
2118	94/1027/98	ADAPTER, jic 12 x 1/2 npt, mm, ss, 3k, 316	2
2119	114496	FITTING, nipple, 1/2 npt x 3/4 npt, ss, 5k	1
2120	61/0002/88❁	TUBE, 3/8 in. od, poly	15 ft

▲ Replacement Danger and Warning labels, tags, and cards are available at no cost.

❁ Not shown.

Water Jacket, SK513

For tapered thread mixing stacks.

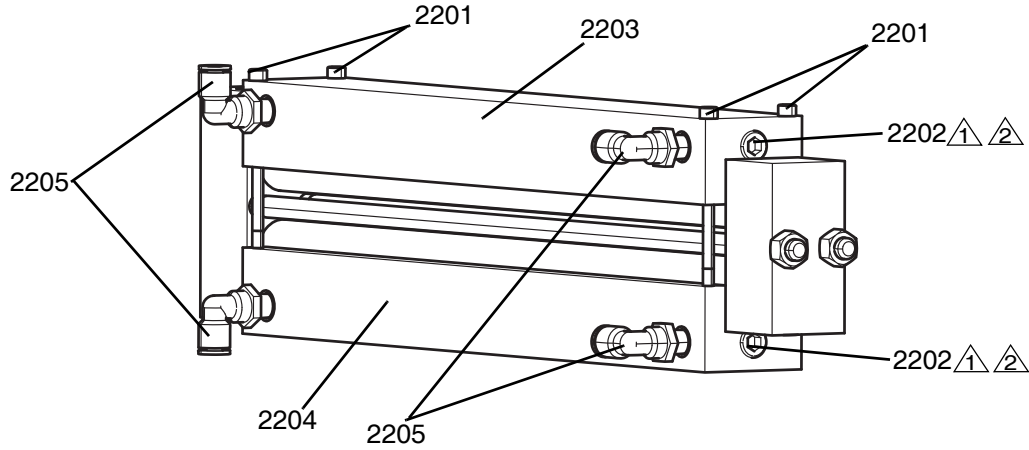

△ 1 Apply a light coating of anti-seize lubricant to all male threads as needed.

△ 2 Apply ceramic tape to all male threads as needed.

NOTE: 2 x ref. 1802 are located on the other end of the water jacket.

FIG. 23: Tapered Thread Water Jacket for Mixer

Ref	Part	Description	Quantity
2201	FAA040560	SCREW, shcs, 10-32 x 3.5, sst	4
2202	101970	PLUG, skt hd, 1/4 npt, ss	4
2203	SM321003	JACKET, water, 16 cartridge	1
2204	SM321005	JACKET, water, 16 cartridge	1
2205	94/0704-1/96	FITTING, elbow, swvl, 1/4 tube x 1/4 npt	4

Tapered Thread Mixer SM396-322

For tapered thread mixing stacks.

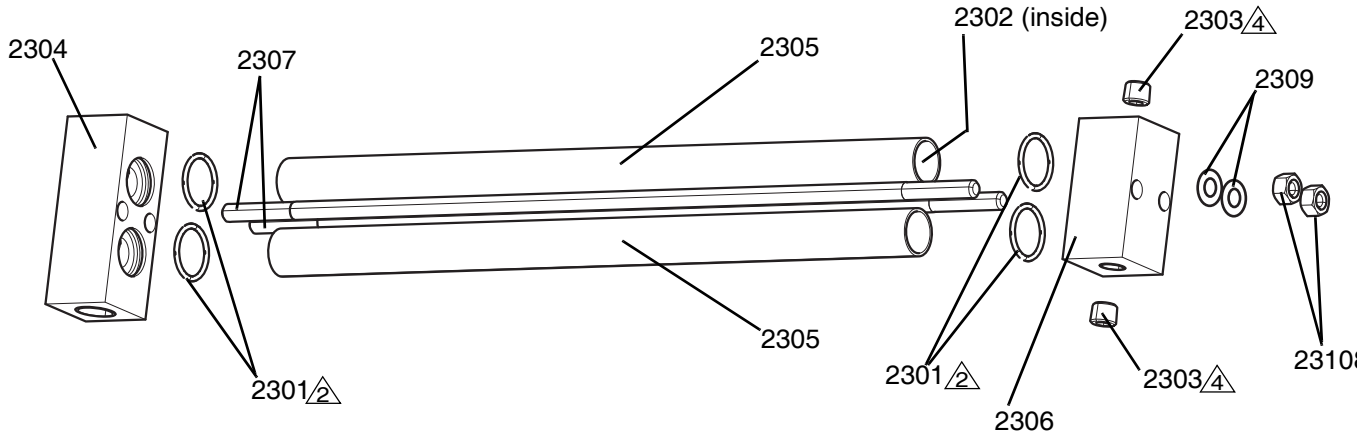

 Apply a light coating of lubricant to seals.

 Apply ceramic tape to all male threads as needed.

Fig. 24: Tapered Thread Mixer

Inside SK513

Ref	Part	Description	Quantity
2301	555690	O-RING, -120 fluoroelastomer-a 75 duro	4
2302	---*	CARTRIDGE, mixer	16
2303	101970	PLUG, skt hd, 1/4 npt, ss	2
2304	SM396004	CAP, 2 pass, mixer, top, sm396-324	1
2305	SM321001	TUBE, element, 1.0 in. od x 16.0, sst	2
2306	SM396002	CAP, 2 pass, mixer, bot, sm396-322	1
2307	SM396003	ROD, tie, sm 396-322, 324, 3/8-16	2
2308	112913	NUT, hex	2
2309	103975	WASHER, lock, 3/8	2

* Available in pack of 24 (part no. 25B006) or pack of 120 (part no. 25B007).

Tapered Thread Mixing Stack, 25A169

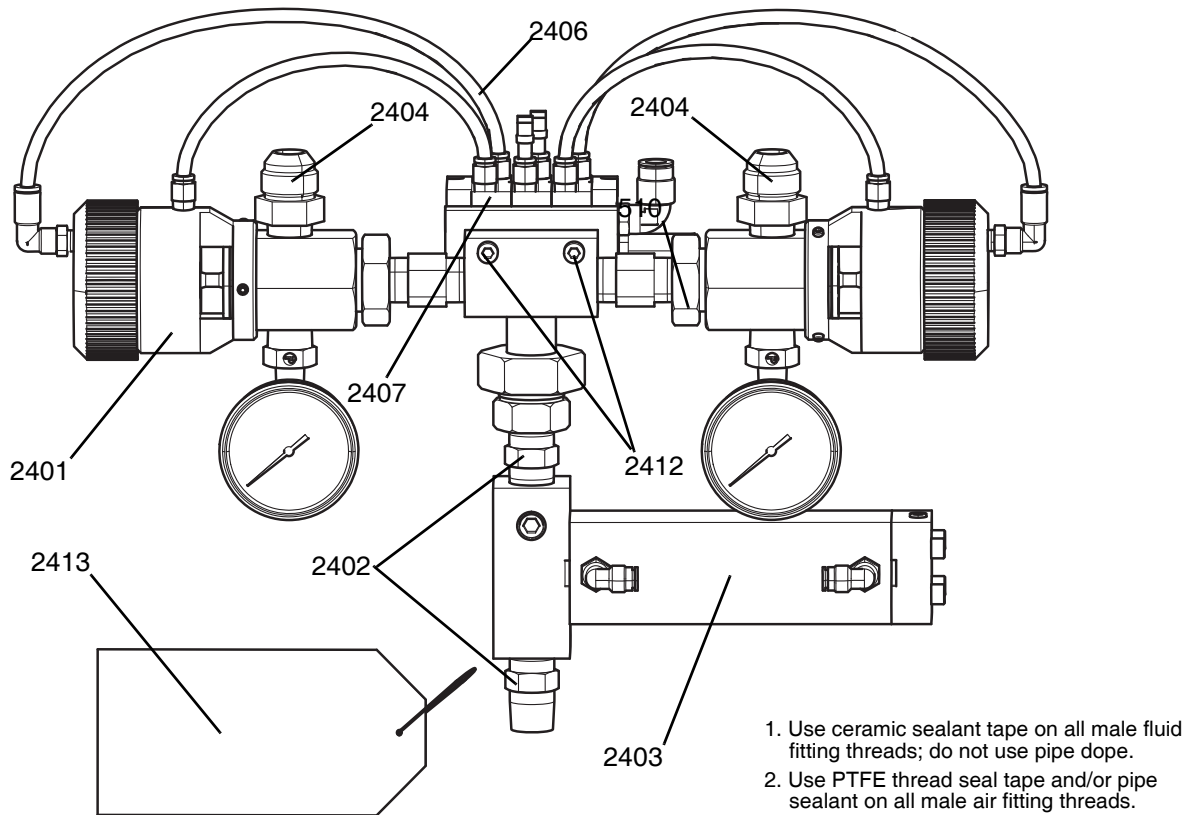

FIG. 25: Tapered Thread Stack 25A169

Ref	Part	Description	Quantity
2401	SA914-5A	MANIFOLD, mixer, assy, gun, 1/2 npt	1
2402	114373	FITTING, nipple, 1/2 npt, sst hex	2
2403	SM370-24	MIXER, 2 pass, 24 elements	1
2404	94/1027/98	ADAPTER, jic 12 x 1/2 npt, mm, ss, 3k, 316	2
2406	61/0001/88	TUBE, 1/4 in. od, poly	4.7 ft
2407	SK579	MANIFOLD, pneumatic, 3-solenoid, lh	1
2408	61/0002/88*	TUBE, 3/8 in. od, poly	15 ft
2412	96/0105/99	SCREW, shc, 1/4-20 x 1.50, ms, e	2
2413	172479▲	TAG, warning	1

▲ Replacement Danger and Warning labels, tags, and cards are available at no cost.

* Not shown.

Water Jacket and Mixer, SM370-24

For tapered thread mixing stacks.

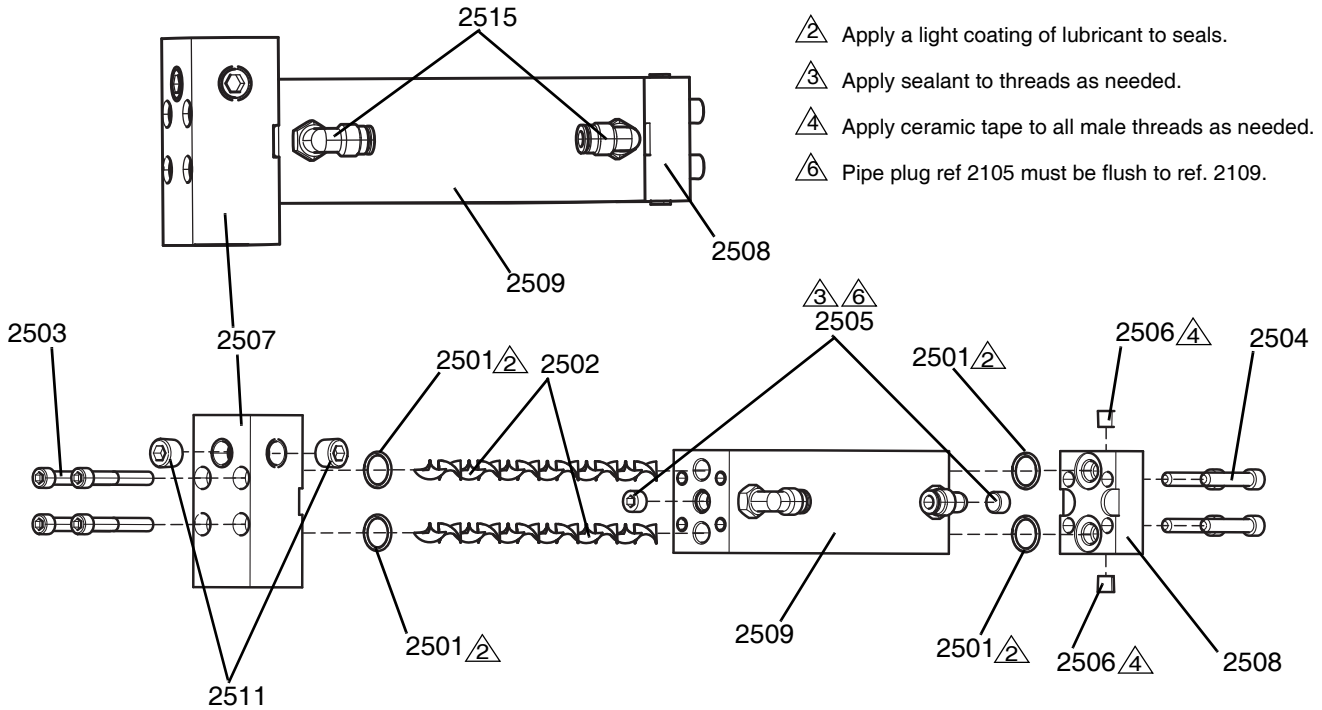
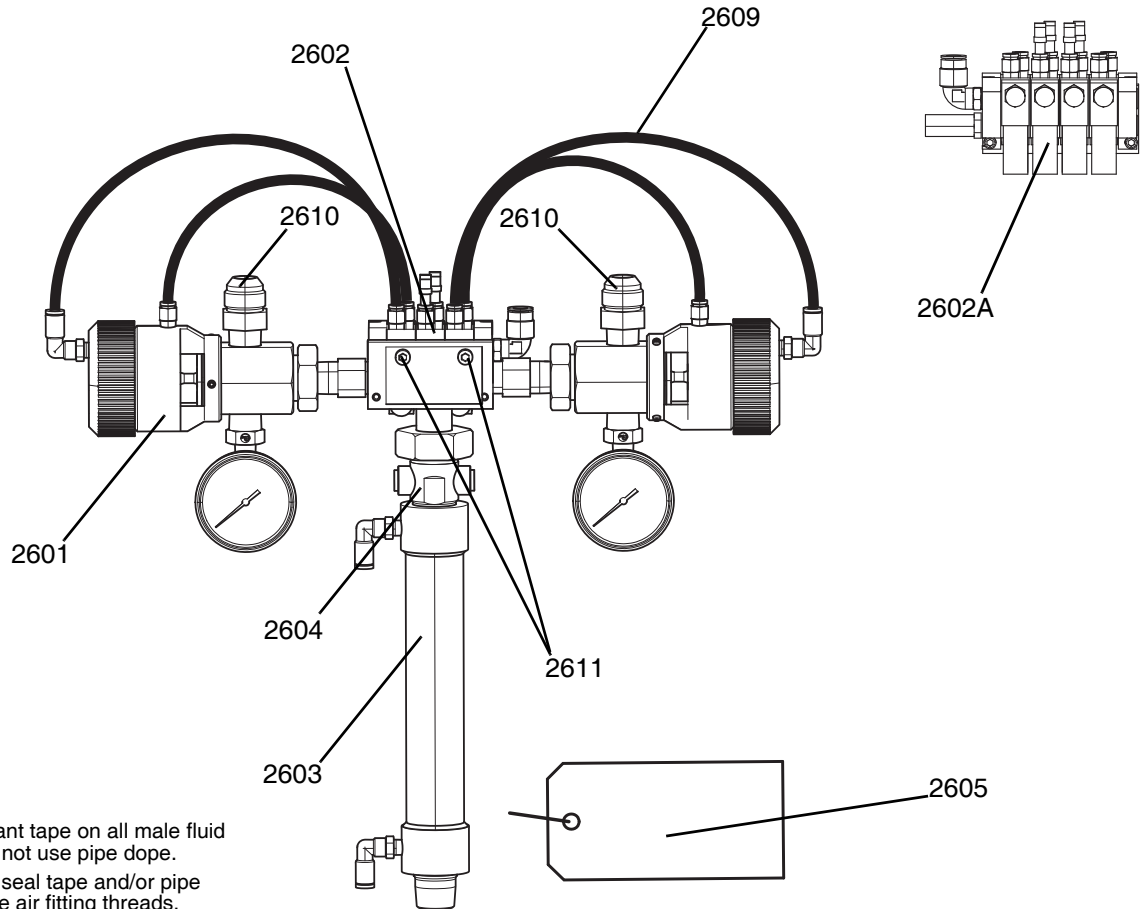

FIG. 26: Tapered Thread Water Jacket and Mixer

Ref	Part	Description	Quantity
2501	115719	PACKING, o-ring, 015,v iton	4
2502	118822	MIXER, 0.363 x 12 el, sst	2
2503	500171	SCREW, shcs, 1/4-20 x 1.75, ss	4
2504	124588	SCREW, cap, sh, 1/4-20 x 1.25 lg, sst	4
2505	110208	PLUG, pipe, 1/8 npt, ss	2
2506	104071	PLUG, pipe, 1/16 npt, ss	2
2507	SM370001	CAP, 2 pass,mixer, top, sm370-24	1
2508	SM370002	CAP, 2 pass, mixer, bot, sm370-24	1
2509	SM370003	HOUSING, 2 pass, mixer, sm370-24	1
2511	101970	PLUG, pipe, 1/4 npt, ss	2
2515	125412	FITTING, elbow, male, swivel	2

Tapered Thread Mixing Stack, SK556 and SK556-2A



1. Use ceramic sealant tape on all male fluid fitting threads; do not use pipe dope.
2. Use PTFE thread seal tape and/or pipe sealant on all male air fitting threads.

FIG. 27: Tapered Thread Stack SK556

SK556

Ref	Part	Description	Quantity
2601	SA914-3A	MANIFOLD, mixer, assy, gun, 1-1/4 - 18th	1
2602	SK579	MANIFOLD, pneumatic, 3-solenoid, lh	1
2603	SM327-WJ	MIXER, water, jacket, medical	1
2604	SM327-12	MIXER, 12 element, medical	1
2605	172479▲	TAG, warning	1
2609	61/0001/88	TUBE, 1/4 in. od, poly	4.7 ft
2610	94/1027/98	ADAPTER, jic 12 x 1/2 npt, mm, ss, 3k, 316	2
2611	96/0105/99	SCREW, shc, 1/4-20 x 1.50, ms, e	2
2618	61/0002/88✿	TUBE, 3/8 in. od, poly	15 ft

SK556-2A

Ref	Part	Description	Quantity
2602A	SK579-2A	MANIFOLD, pneumatic, 4-solenoid, lh	1

▲ Replacement Danger and Warning labels, tags, and cards are available at no cost.

✿ Not shown.

Water Jacket, SM327-WJ, and Mixer, SM327-12
For tapered thread mixing stacks.

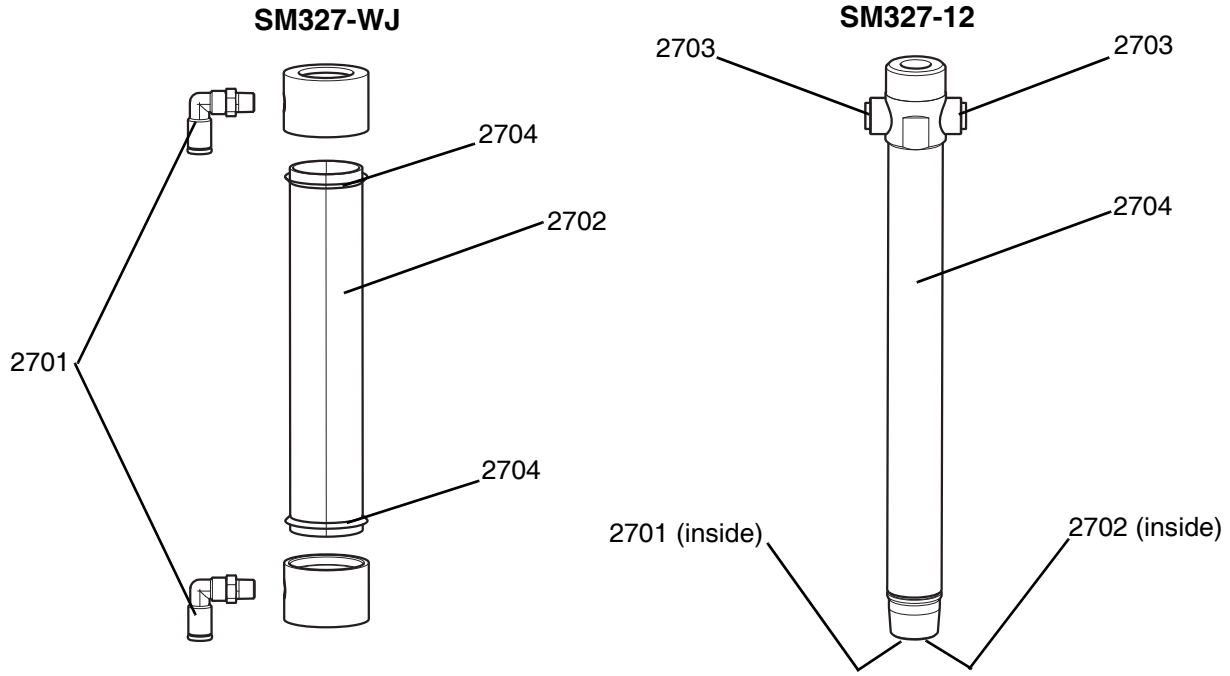

FIG. 28: Tapered Thread Water Jacket and Mixer

SM327-WJ

Ref	Part	Description	Quantity
2701	112781	ELBOW, swivel, 90 deg	2
2702	24P868	KIT, housing, mixer, water, jacket	1
2703	040644✿	RETAINER, ring, external, ss	1
2704	154662	PACKING, o-ring	2

SM327-12 - Inside SM327-WJ

Ref	Part	Description	Quantity
2701	FAA040586	MIXER, 12 element, ss	1
2702	040704	SCREW, hollow, lock, steel	1
2703	94/0370/98	PLUG, skt hd, 1/4 npt, ss	2
2704	SM327003	HOUSING, mixer, assy, 16 mmx 12 el	1

✿ Not shown.

Manifold Assembly, SA914-3A/-5A

For tapered thread mixing stacks.

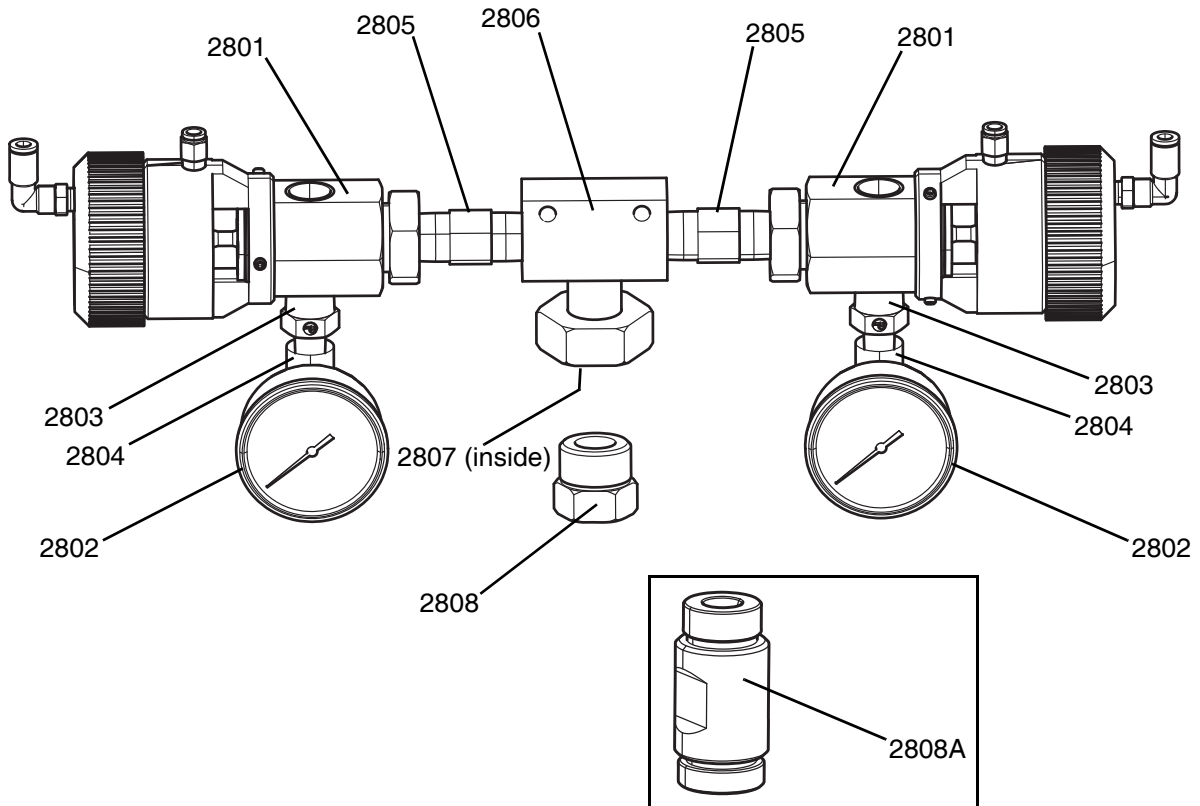

FIG. 29: Tapered Thread Manifold Assembly

SA914-3A

Ref	Part	Description	Quantity
2801	SG263-1A	GUN, shut off, single, mat'l	2
2802	080103	GAUGE, 5000 psi, liquid, 2.5 in.	2
2803	16C633	FITTING, nipple, hex, 1/2 x 1/4, m x m, ss	2
2804	108417	ELBOW, female, 1/4 npt, fxf, 5k, sst	2
2805	080856	VALVE, check, 25#, ss, 1/2 in. nptm	2
2806	24P867	KIT, manifold, base, 3-way, assy	1
2807	108519	PACKING, o-ring	1

SA914-5A - Parts above and the following:

Ref	Part	Description	Quantity
2808	SA914007	ADAPTER, sa 914, 1/2 in. nptf	1

Adapter for straight thread mixers:

Ref	Part	Description	Quantity
2808A	17M397*	ADAPTER, 1-3/8 in. x 1-1/4 in.	1

* Order separately.

Manifold On/Off Valves, SG263-1A

For tapered thread mixing stacks.

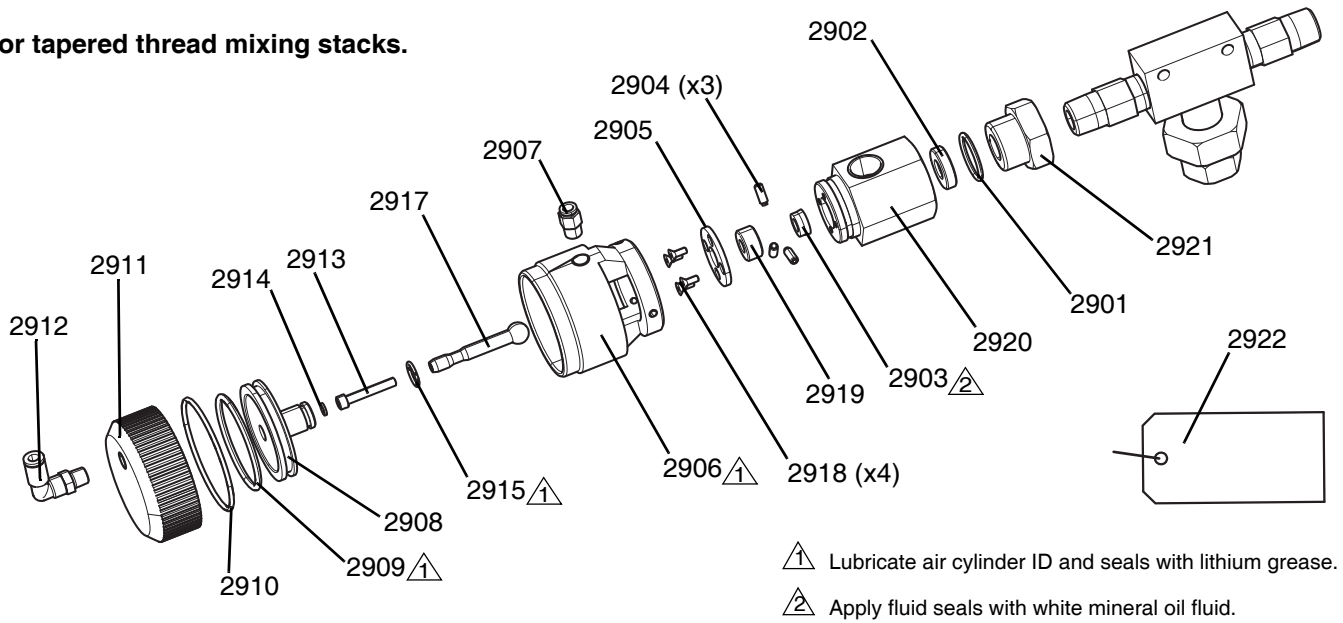

- ▲1 Lubricate air cylinder ID and seals with lithium grease.
- ▲2 Apply fluid seals with white mineral oil fluid.

Fig. 30: Tapered Thread Manifold On/Off Valves

Ref	Part	Description	Quantity
2901	107204†	PACKING, o-ring	1
2902	SG263008†	SEAT, carbide, .500 ball,. 999 od	1
2903	01161S†	SEAL, poly, 9/16 od, 5/16 id, 1/8 cs	1
2904	FAA041448	SCREW, set, hex, socket, 10-24	3
2905	SG263004	WASHER, gun, single, mat'l	1
2906	SG263003	CYLINDER, gun, single, mat'l	1
2907	123371	FITTING, connector, 1/4 tub x 1/8 npt, b	1
2908	SG263002	PISTON, gun, single, mat'l	1
2909	156641†	PACKING, o-ring	1
2910	00095B†	O-RING, packing, o-ring, buna	1
2911	SG263001	CAP, gun, single, mat'l	1
2912	112781	ELBOW, swivel, 90 deg	1
2913	112756	SCREW, cap, socket hd	1
2914	C19277	WASHER, lock, split, hi-collar	1
2915	C20145†	PACKING, o-ring, buna-n	1
2917	SG263005†	PLUNGER, gun, single, mat'l	1
2918	297862	SCREW, cap, flat head	4
2919	SG263006†	BEARING, gun, single, mat'l	1
2920	SG263007	BODY, gun, single, mat'l	1
2921	SG263009	FITTING, gun, single, 1-3/16-12th dm,	1
2922	172479▲	TAG, warning	1

† Parts are available in repair kit 25A173.

▲ Replacement Danger and Warning labels, tags, and cards are available at no cost.

Solenoid Blocks, SK579/-2A
For tapered thread mixing stacks.

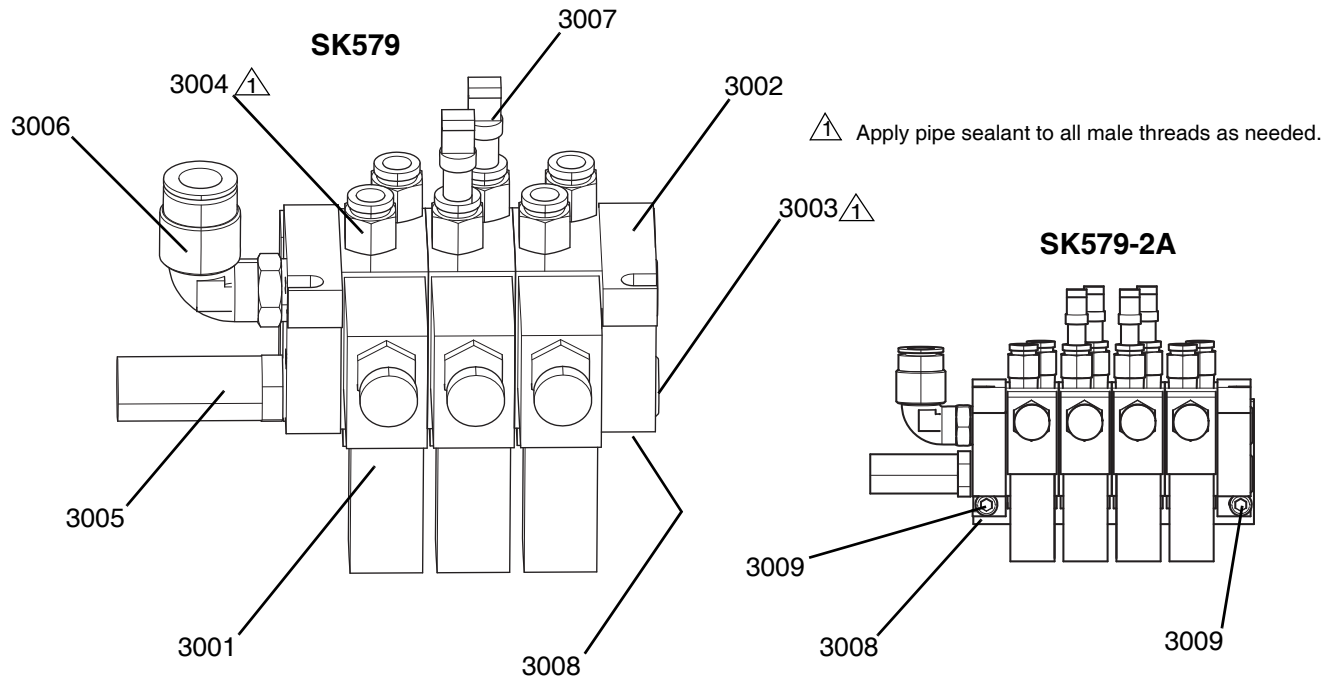

FIG. 31: Tapered Thread Solenoid Block

Ref	Part	Description	SK579 Quantity	SK579-2A Quantity
3001	060247	SOLENOID, pneumatic, 1/8 in., npt	3	4
3002	060255	PLATE, end, kit	1	1
3003	100721	PLUG, pipe	2	2
3004	123371	FITTING, connector, 1/4 tub x 1/8 npt, b	6	8
3005	080111	MUFFLER, 1/4 in. npt, brass	1	1
3006	121018	FITTING, elbow, male, swivel, 1/4 npt	1	1
3007	21604-01	PLUG, plug, tube, plastic, 1/4 in. dia.	2	4
3008	SR645006	PLATE, solenoid, base	1	
	SR645010	PLATE, mounting, 4-valve		1
3009	15D256	SCREW, cap, sch	2	2

Material In-line Filter, SA925-1A

For tapered thread mixing stacks.

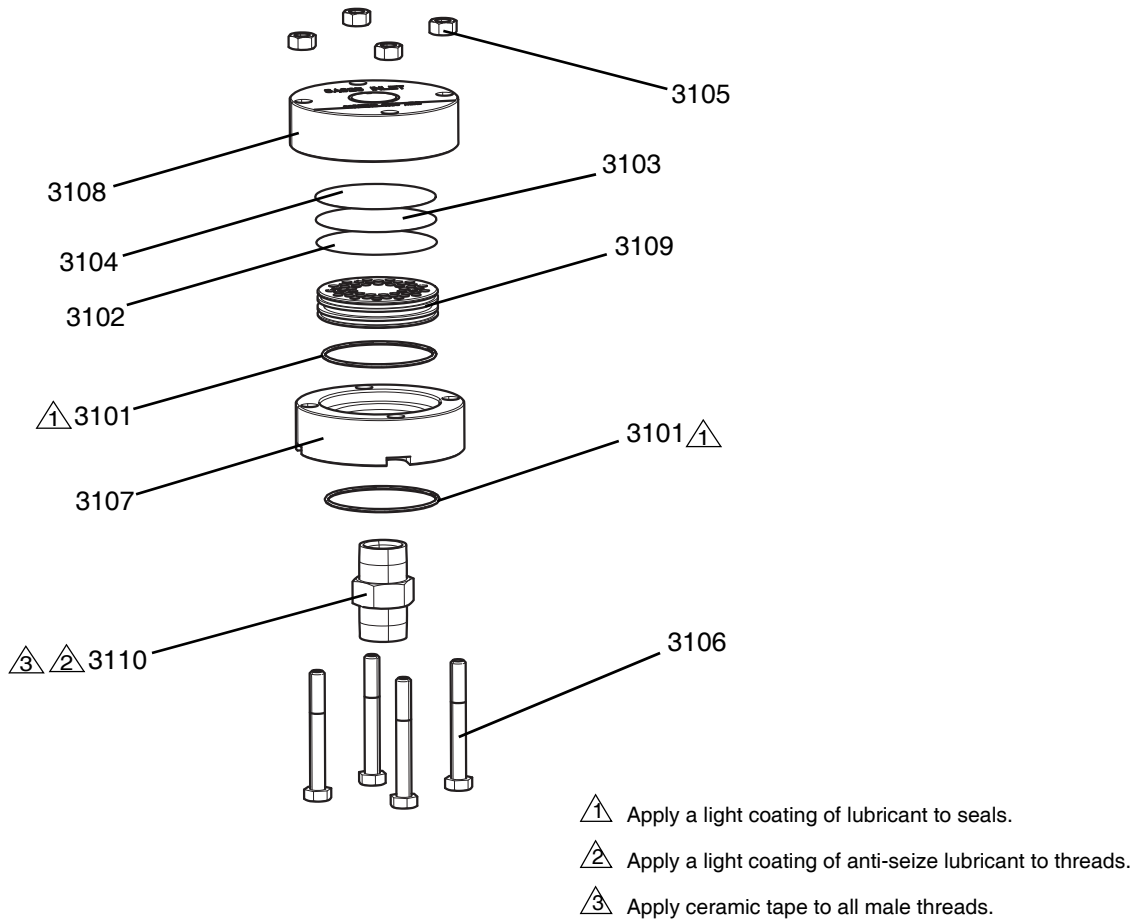
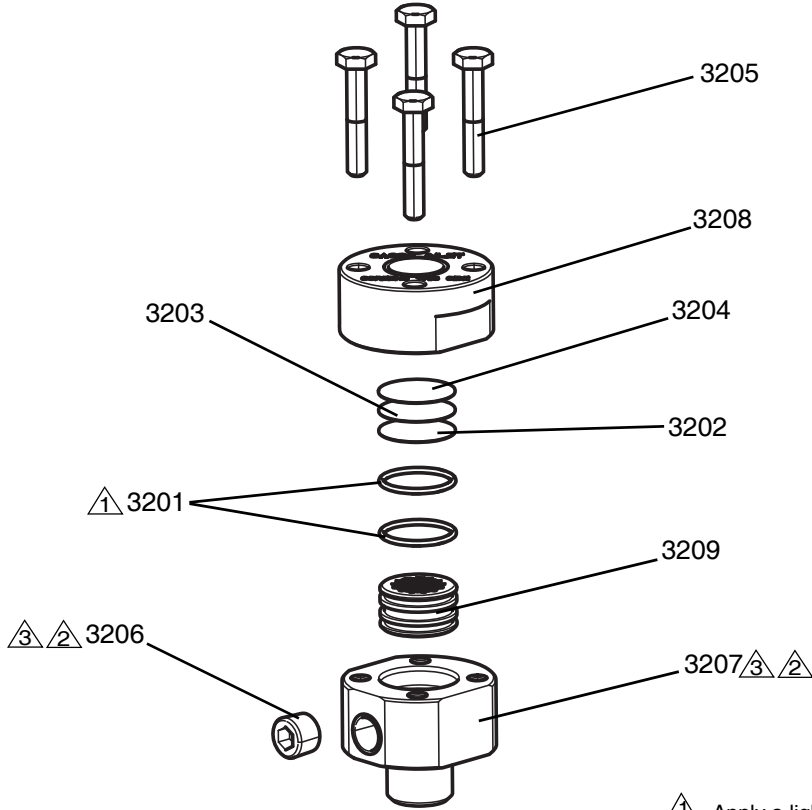

FIG. 32: Tapered Thread In-line Filter SA925-1A

Ref	Part	Description	Quantity
3101	112245	PACKING, o-ring	2
3102	FAA040512	SCREEN, filter, 2.5 od, 80 mesh, sst	1
3103	FAA040513	SCREEN, filter, 2.5 od, 100 mesh, sst	1
3104	FAA040514	SCREEN, filter, 2.5 od, 200 mesh, sst	1
3105	FAA040540	NUT, hex, 5/16-18, cs, gr8, u-coat	4
3106	FAA040541	SCREW, hhc, 5/16-18 x 2.50, cs, gr8, u	4
3107	SA925001	HOUSING, outlet, 3/4 npt	1
3108	SA925003	HOUSING, inlet, 3/4 npt	1
3109	SA925006	SUPPORT, screen	1
3110	123111	FITTING, nipple, hex, 3/4 npt, 3k, ss	1

Material In-line Filter, SA926-1A

For tapered thread mixing stacks.



- ① Apply a light coating of lubricant to seals.
- ② Apply a light coating of anti-seize lubricant to threads.
- ③ Apply ceramic tape to all male threads.

FIG. 33: Tapered Thread In-line Filter SA926-1A

Ref	Part	Description	Quantity
3201	103413	PACKING, o-ring	2
3202	040768†	SCREEN, woven wire, 1 in. dia, 80 mesh	1
3203	040769†	SCREEN, woven wire, 1 in. dia, 100 mesh	1
3204	040770†	SCREEN, woven wire, 1 in. dia, 200 mesh	1
3205	114238	SCREW, cap, hex hd	4
3206	101970	PLUG, pipe, hdls	1
3207	SA926001	HOUSING, outlet, 1/2 in. npt	1
3208	SA926002	HOUSING, inlet, 1/2 in. npt	1
3209	SA926003	SUPPORT, screen	1

† Parts are available in rebuild kit 25A915.

Material Regulators, SA920-G and SA921-G

For tapered thread mixing stacks.

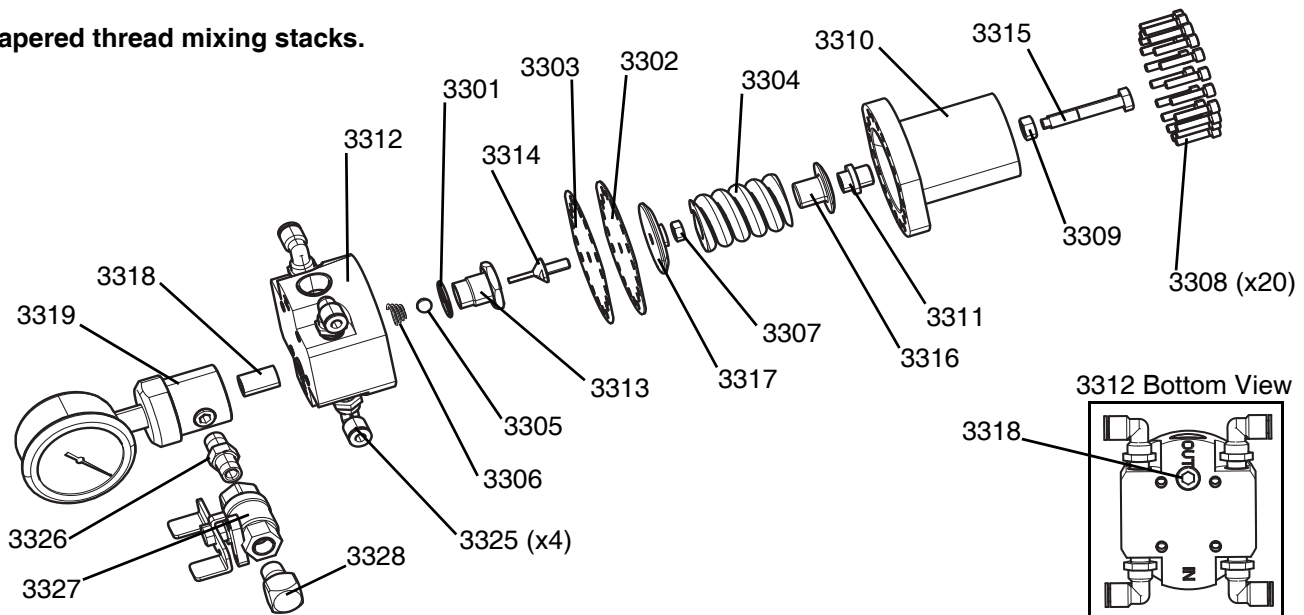

FIG. 34: Tapered Thread Material Regulators

Ref	Part	Description	Quantity
3301	---◆	O-RING, -019 fluoroelastomer a 75 duro	1
3302	---◆	DIAPHRAGM, polypropylene, sa92x	1
3303	---◆	DIAPHRAGM, ptfе, sa92x	1
3304	FAA040308	SPRING, comp, 1.43 od x 2.13 lg, zinc	1
3305	FAA040309	BALL, 11/32 dia, tc, gr 25, 92 rc	1
3306	FAA040310	SPRING, comp, conical, sa921	1
3307	FAA040480	NUT, nlock, hex, 1/4-28, gr 2, zin	1
3308	---	SCREW, shc, 10-32 x 0.88, ss	20
3309	FAA040484	NUT, jam, hex, 5/16-24, gr 5, zinc	1
3310	SA920001	CHAMBER, spring, cap, sst	1
3311	SA920002	PLUG, spring, cap, cs	1
3312	SA920003	BASE, material, regulator (SA920-G)	1
	SA921001	BASE, in/out, matl, 3/4 npt (SA921-G)	1
3313	SA920005	VALVE, assy, retainer, seat	1
3314	SA920006	SCREW, stem, valve, cs, chrome	1
3315	SA920007	SCREW, hhc, 5/16-24 x 1.88, ss, cust	1
3316	SA920008	CAP, retainer/guide, spring, cs	1
3317	SA921005	PLATE, oscillator, spring, cs, zinc	1
3318	---	FITTING, nipple, 1/4 mpt x .875 sst	1
3319	080690	GAUGE, press, 0-1 kpsi, 1/4 nptm, bm	1
3325	---	FITTING, elbow, swvl, 1/4 tube x 1/4 npt	4
3326	121907	FITTING, nipple, hex, 1/4 npt, sst, swv	1
3327	080803	VALVE, ball, 1/4 in. f, 2k psi, 316 ss	1
3328	---	FITTING, elbow, street	1

--- Not available for individual sale.

◆ Parts are available in kit SA920K.

Color Injector Kit, 25A108

For tapered thread mixing stacks.

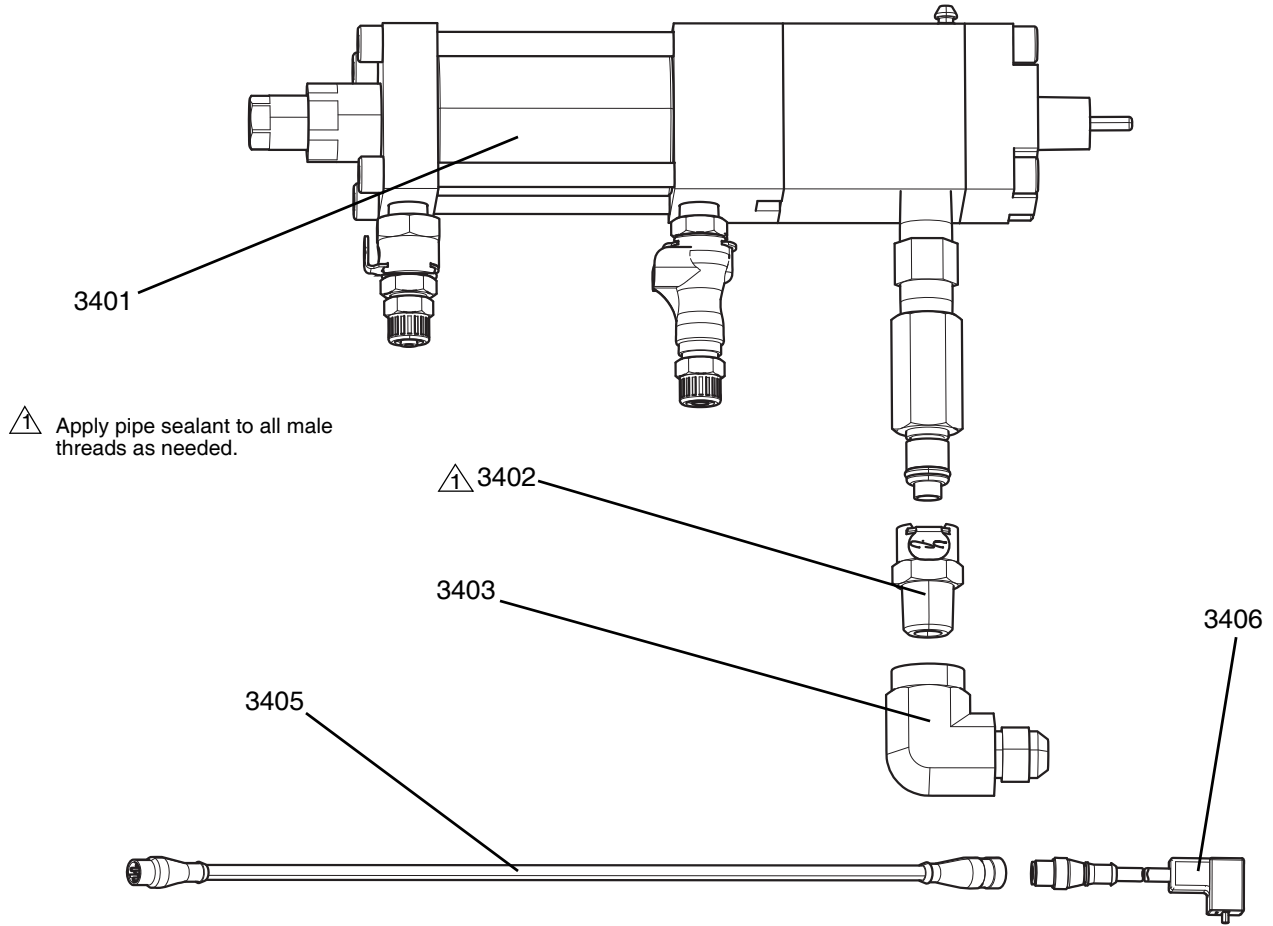
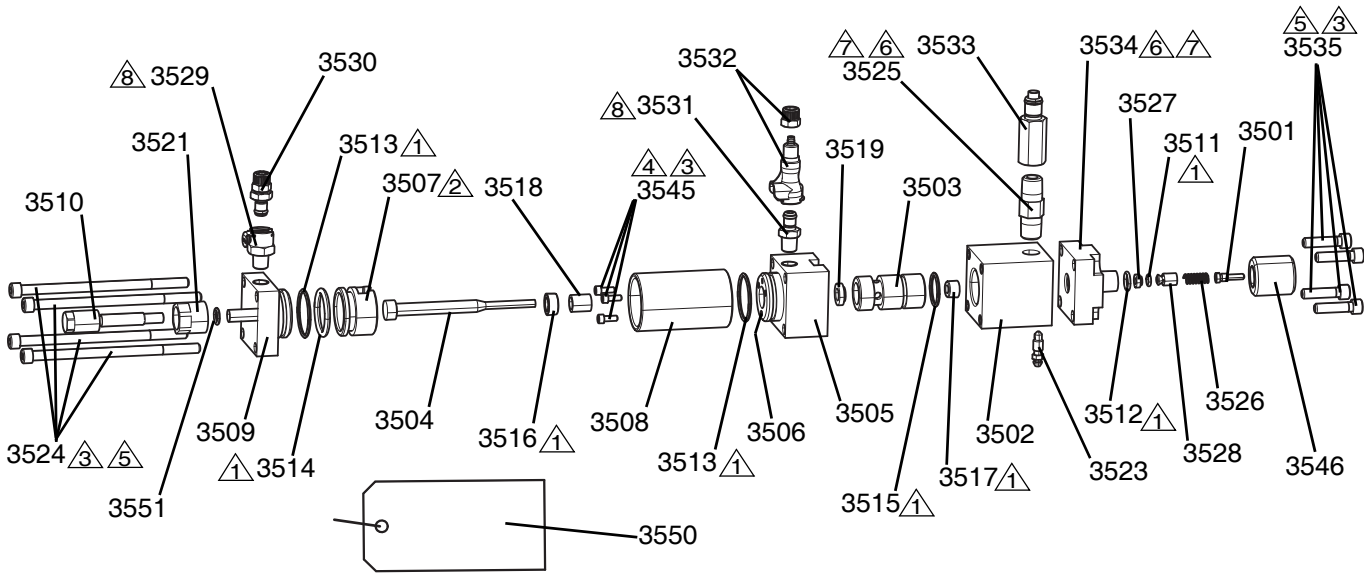

FIG. 35: Tapered Thread Color Injector

Ref	Part	Description	Quantity
3401	SN751-1A	INJECTOR, assy, color	1
3402	081076	HOUSING, body, qd, 1/4 npt m, crplt, brs	1
3403	080071	FITTING, elbow, 90, jic 6 x 1/4 npt, mf	1
3405	24E899	CABLE, 5 pin, male/female, 4.0 m	1
3406	125750	CORD SET, euro/male, din/female, rev	1

Color Injector Assembly, SN751-1A



- △1 Apply a light coating of lubricant to seals.
- △2 Apply a light coating of lubricant to piston.
- △3 Apply a light coating of anti-seize lubricant to threads.
- △4 Torque fasteners to 16-18 in-lbs or 2 ft-lbs (2 N•m).
- △5 Torque fasteners to 95-98 in-lbs or 8 ft-lbs (11 N•m).
- △6 Apply a light coating of anti-seize lubricant to all male threads.
- △7 Apply ceramic tape to all male threads.
- △8 Apply PTFE tape to all male threads.

FIG. 36: Injector Assembly

Ref	Part	Description	Quantity
3501	SN750002	INJECTOR, screw, color, injector	1
3502	SN751002	BLOCK, color, injector	1
3503	SN751003	INSERT, color, injector	1
3504	SN751004	PIN, color, injector	1
3505	SN751005	CAP, front, color, injector	1
3506	SN751006	SEAL, retainer, color, injector	1
3507	SN751007	PISTON, color, injector	1
3508	SN751008	CYLINDER, color, injector	1
3509	SN751009	CAP, rear, color, injector	1
3510	17E105	ROD, push, color	1
3511	556553	O-RING, -008 fluoroelastomer-a 75 duro	1
3512	106555	PACKING, o-ring	1
3513	559013	O-RING, (-024) fluoroelastomer-75 duro	2
3514	160516	PACKING, o-ring, 214	1
3515	555684	O-RING, -018 fluoroelastomer-a 75 duro	1
3516	01070B	SEAL, poly, 9/16 od, 5/16 id, 1/4 cs	1
3517	01071U	SEAL, poly, 7/16 od, 3/16 id, 1/4 cs	1
3518	020080	BEARING, sleeve, 7/16 in., od x 5/16in.	1
3519	FAA040247	WIPER, d, style, 5/16 in. od, buna	1

3521	17E104	RING, lock, rotation	1
3523	040652	SCREW, bleeder, 1/4-28 x 59/64 lg	1
3524	556511	SCREW 1/4-20 x 4.50 soc hd cap	4
3525	080006	VALVE, check, 1/4 npt x 1/4 npt, sst	1
3526	080431	SPRING, 50 psi, ss	1
3527	080268	VALVE, insert, ss	1
3528	080270	POPPET, ss	1
3529	080503	COUPLING, qc, 1/8in. nptm x 1/8 in. flow	1
3530	080502	COUPLING, 1/8 in. flow x 1/4 in. od (.170 in. id)	1
3531	080143	FITTING, 1/8 in. nptm x 1/8 in. qc	1
3532	080459	HOSE, 1/8 in. x 1/4 in. od (.170 in. id)	1
3533	080504	COUPLING, qc, 1/4 in. nptf x 1/4 in. flow	1
3534	SN751001	BODY, valve, color, injector	1
3535	C19810	SCREW, cap, socket hd	4
3545	102410	SCREW, cap socket hd, #6	3
3546	SN751021	CAP, nose, injector, color	1
3550	172479▲	TAG, warning	1
3551	7606-08	O-RING, o-ring, buna n, 2-011	1

▲ Replacement Danger and Warning labels, tags, and cards are available at no cost.

Colorant Tank Kit, 25A104

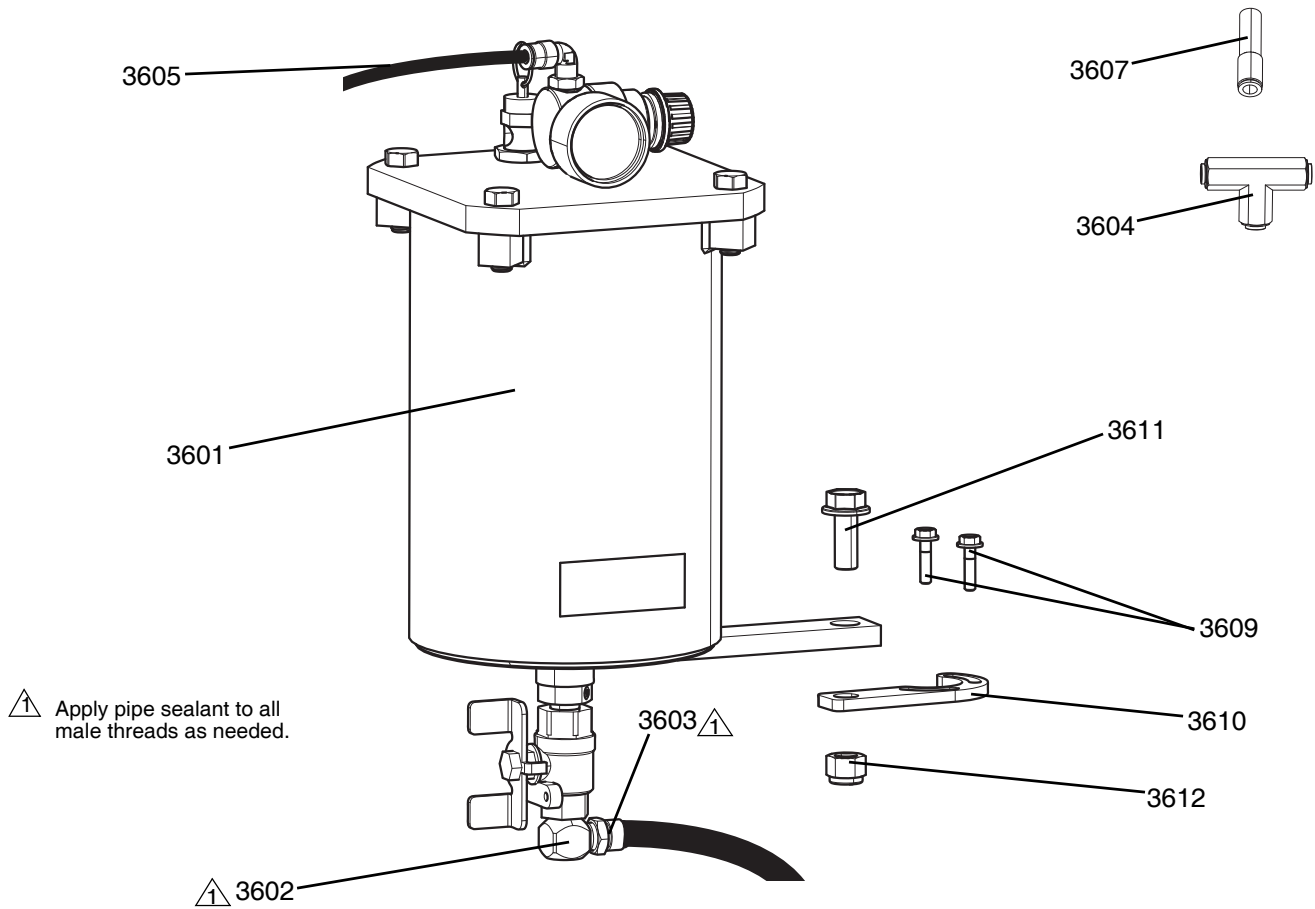

FIG. 37: Colorant Tank 25A104

Ref	Part	Description	Quantity
3601	ST802	TANK, 3-quart, feed, cs, nkl-plt	1
3602	16A006	FITTING, elbow, street, sst	1
3603	122991	ADAPTER, jic 6 x 1/4, mm, ss, 6k, 316	1
3604	123112	FITTING, t, 1/4 tube, prestolock, brs	1
3605	61/0001/88	TUBE, 1/4 in. od, poly	10 ft
3607	23210-01	FITTING, reducer, tube, 3/8 x 1/4 tube	1
3609	128457	SCREW, mach, hex flange, hd	2
3610	25A110	BRACKET, tank, 3l	1
3611	111195	SCREW, cap, flange, hd	1
3612	801020	NUT, lock, hex	1

3-quart Tank, ST802

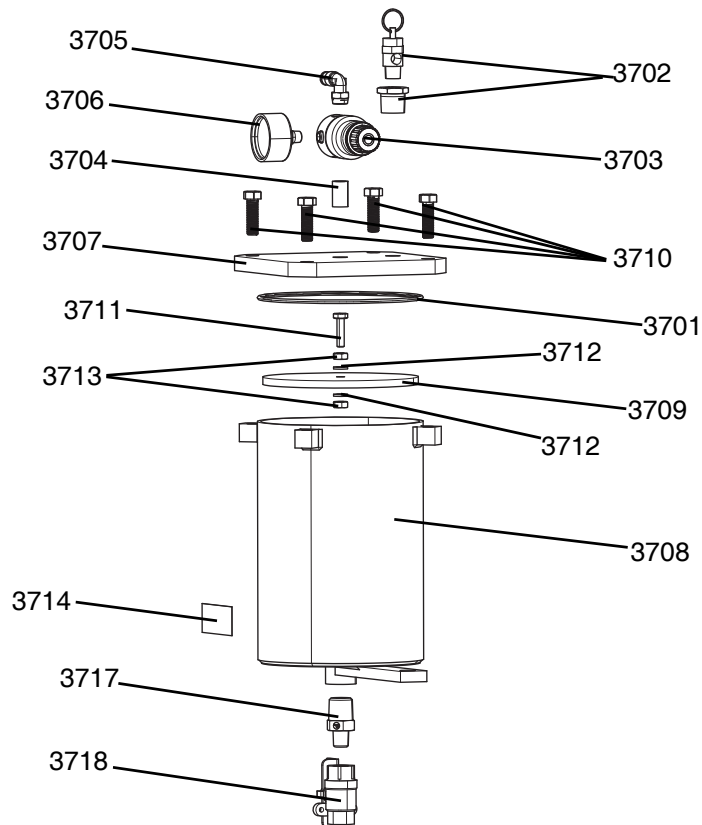

FIG. 38: 3-quart Tank

Ref	Part	Description	Quantity
3701	00181B	O-RING, buna, 254, 70 d	1
3702	94/0762/99	VALVE, relief, 1/4 npt, m, 115 psi, sil	1
3703	080003	REGULATOR, air, 0-100 psi, 1/4" npt	1
3704	555443	FITTING, nipple 1/4 npt x .875 sst	1
3705	121022	FITTING, elbow, male, 1/4 npt	1
3706	113911	GAUGE, pressure, air	1
3707	ST802002	TANK, lid, feed, 3-qt, (2)1/4 npt	1
3708	---	KIT, tank, main, feed, 3-qt, 1/2 npt	1
3709	ST802003	PLATE, follow, 3-quart, uhmw	1
3710	96/0445/99	SCREW, shc, 3/8-16 x 2.00, ms, e	4
3711	109058	SCREW, cap, hex head	1
3712	104123	WASHER, lock, spring	2
3713	102025	NUT, full, hex, regular	2
3714	L0000095▲	LABEL, plte, warning-do not service	1
3717	16C633	FITTING, nipple, hex, 1/2 x 1/4, mxm, ss	1
3718	080803	VALVE, ball, 1/4 in. f, 2k psi, 316 ss	1

--- Not available for individual sale.

▲ Replacement Danger and Warning labels, tags, and cards are available at no cost.

Colorant Tank Kit, 25A105

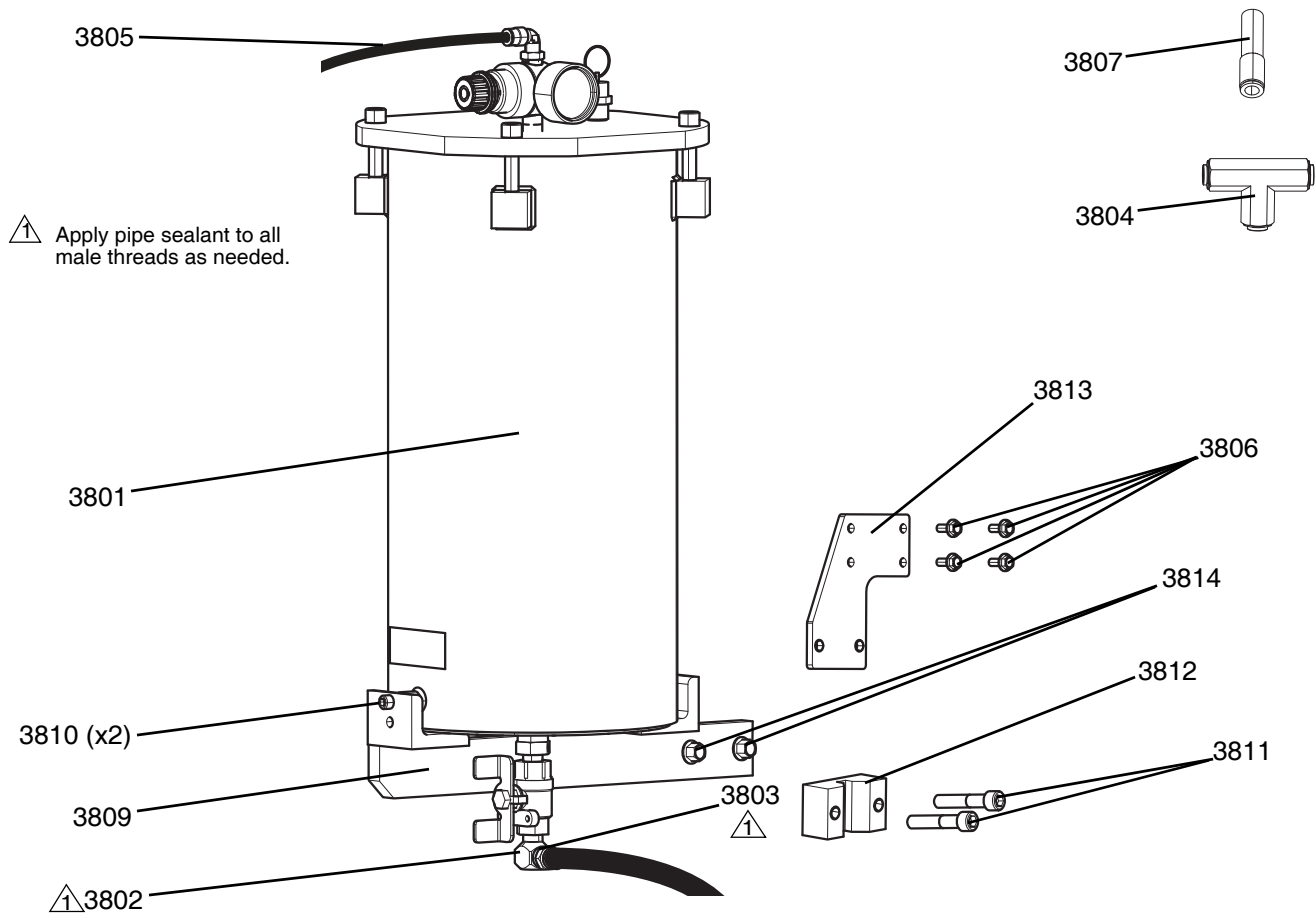

FIG. 39: Colorant Tank 25A105

Ref	Part	Description	Quantity
3801	ST830	TANK, 3 gallon, feed	1
3802	16A006	FITTING, elbow, street, sst	1
3803	122991	ADAPTER, jic 06 x 1/4, mm, ss, 6k, 316	1
3804	123112	FITTING, t, 1/4 tube, prestolock, brs	1
3805	61/0001/88	TUBE, 1/4 in. od, poly	10 ft
3806	114182	SCREW, mach, hex flange	4
3807	23210-01	FITTING, reducer, tube, 3/8 x 1/4 tube	1
3809	24P891	KIT, bracket, mount, tank	1
3810	121112	SCREW, cap, socket head	2
3811	C19843	SCREW, cap, socket head	2
3812	ST830007	BLOCK, mount, tank	1
3813	25A114	BRACKET, tank, 11 l, white	1
3814	127048	SCREW, mach, hex, flange, m10 x 1.5 x 2	2

3-gallon Tank, ST830

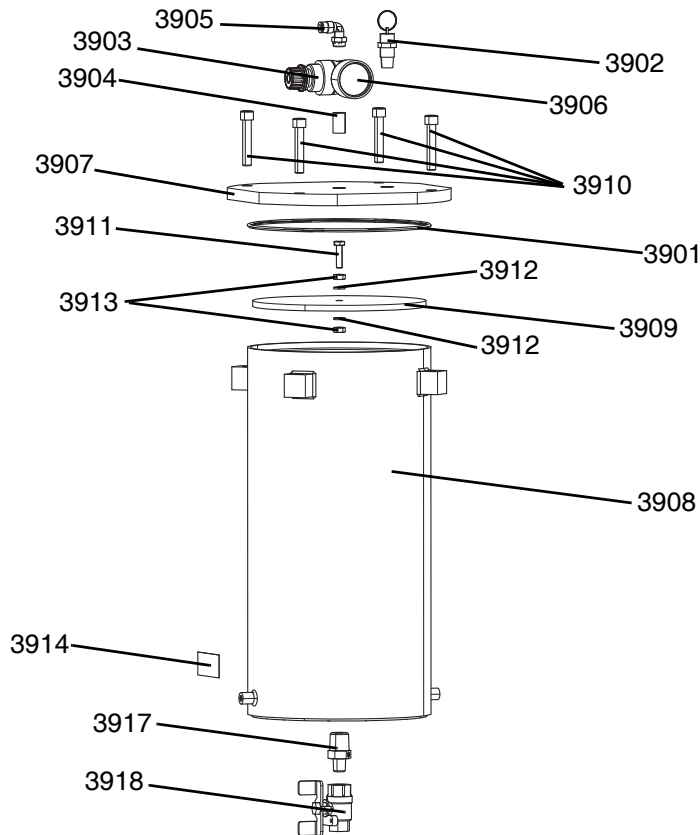

FIG. 40: 3-gallon Tank

Ref	Part	Description	Quantity
3901	00192B	O-RING, 2-265	1
3902	94/0762/99	VALVE, relief, 1/4 npt, m, 115 psi, sil	1
3903	080003	REGULATOR, air, 0-100 psi, 1/4" npt	1
3904	555443	FITTING, nipple 1/4 npt x .875 sst	1
3905	121022	FITTING, elbow, male, 1/4 npt	1
3906	113911	GAUGE, pressure, air	1
3907	ST830001	TANK, lid, feed	1
3908	---	KIT, tank, main, feed	1
3909	ST830005	TANK, plate, feed	1
3910	96/0445/99	SCREW, shc, 3/8-16 x 2.00, ms, e	4
3911	109058	SCREW, cap, hex head	1
3912	104123	WASHER, lock, spring	2
3913	102025	NUT, full, hex, regular	2
3914	L0000095▲	LABEL, plte, warning-do not service	1
3917	16C633	FITTING, nipple, hex, 1/2 x 1/4, mxm, ss	1
3918	080803	VALVE, ball, 1/4 in. f, 2k psi, 316 ss	1

--- Not available for individual sale.

▲ Replacement Danger and Warning labels, tags, and cards are available at no cost.

Color Flow Meter Kits, 25A103 and 25A161

⚠ Apply pipe sealant to all male threads as needed.

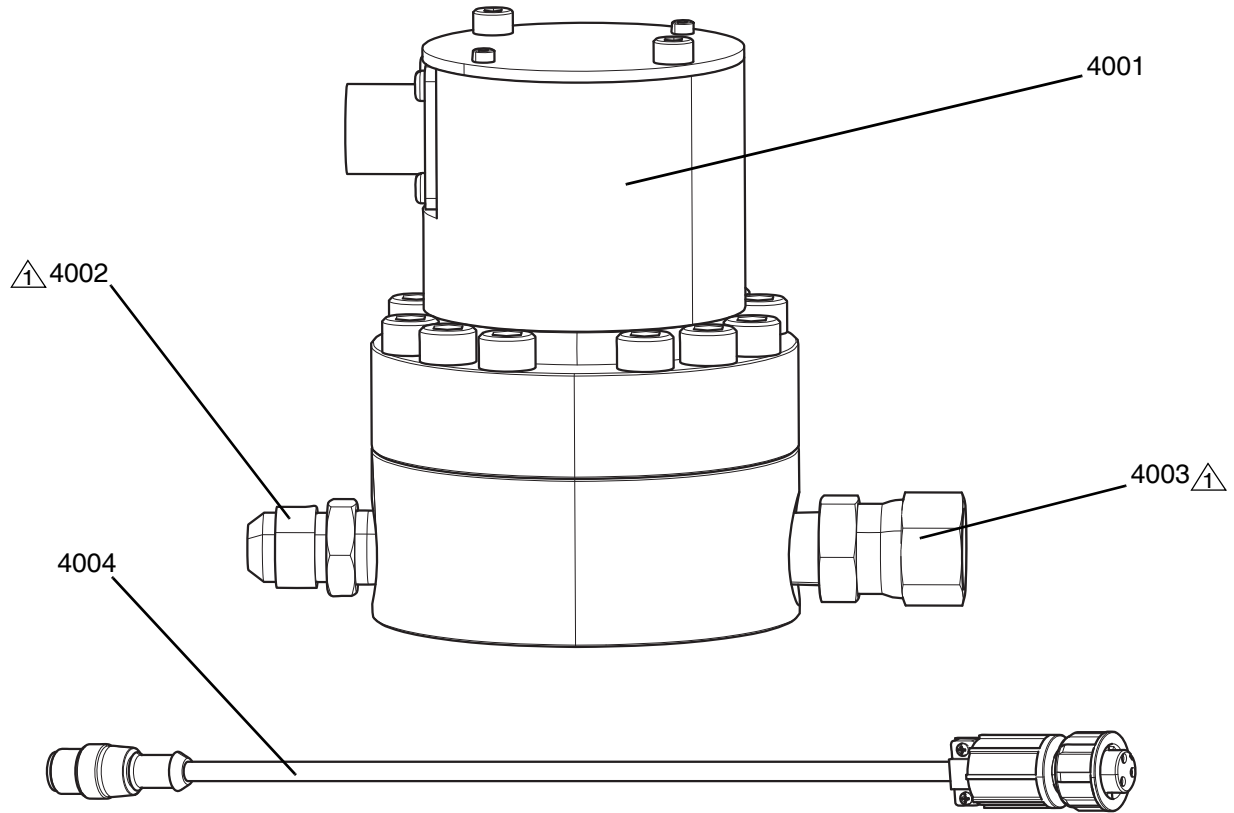

FIG. 41: Color Flow Meter

Ref	Part	Description	Quantity	
4001	---	METER, gear, assy, G3000HR	1	25A103
4001	---	METER, gear, assy, G3000	1	25A161
4002	122991	ADAPTER, jic 6 x 1/4, mm, ss, 6k, 316	1	
4003	122961	ADAPTER, swvl, jic 6 x 1/4 npt, fm, ss, 5	1	
4004	17E305	CABLE, m12 x cir, 5p x 3p, mxf, 4m	1	

--- Not available for individual sale.

Continuous Level Sensor Kit, 25A100

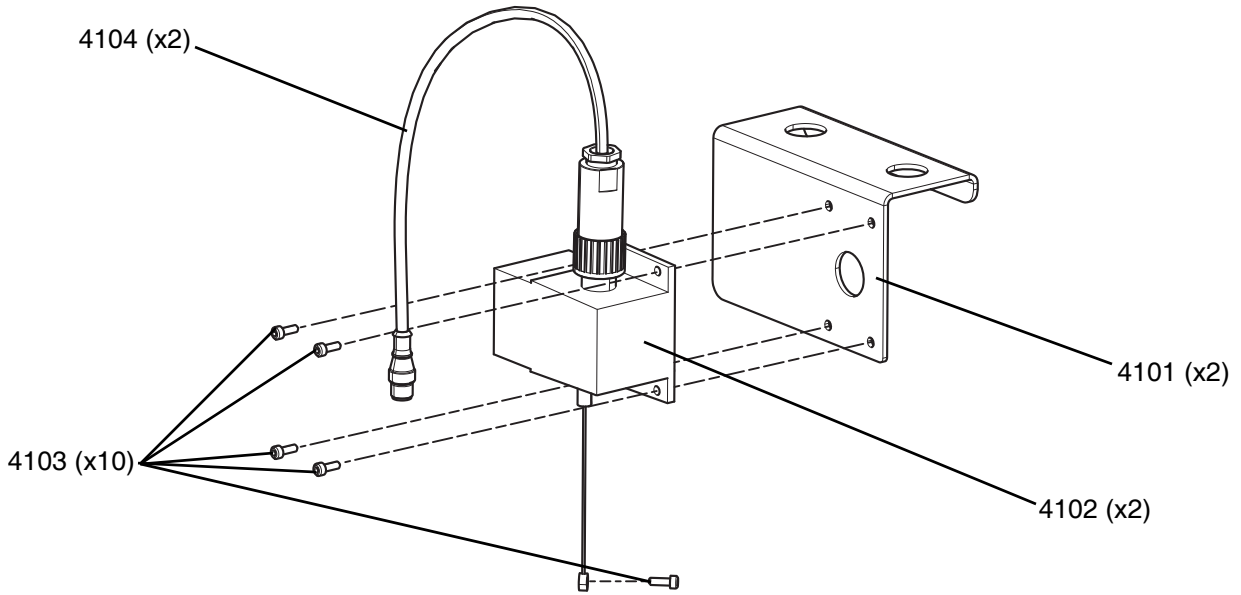

FIG. 42: Continuous Level Sensor 25A100

Ref	Part	Description	Quantity
4101	25A257	BRACKET, sensor, assy, white	2
4102	17E314	SENSOR, pot, string	2
4103	116475	SCREW, shcs, m 4 x 12	10
4104	17E317	CABLE, gca, 5p x 6p, mx	2

Continuous Level Sensor Kit, 25A101

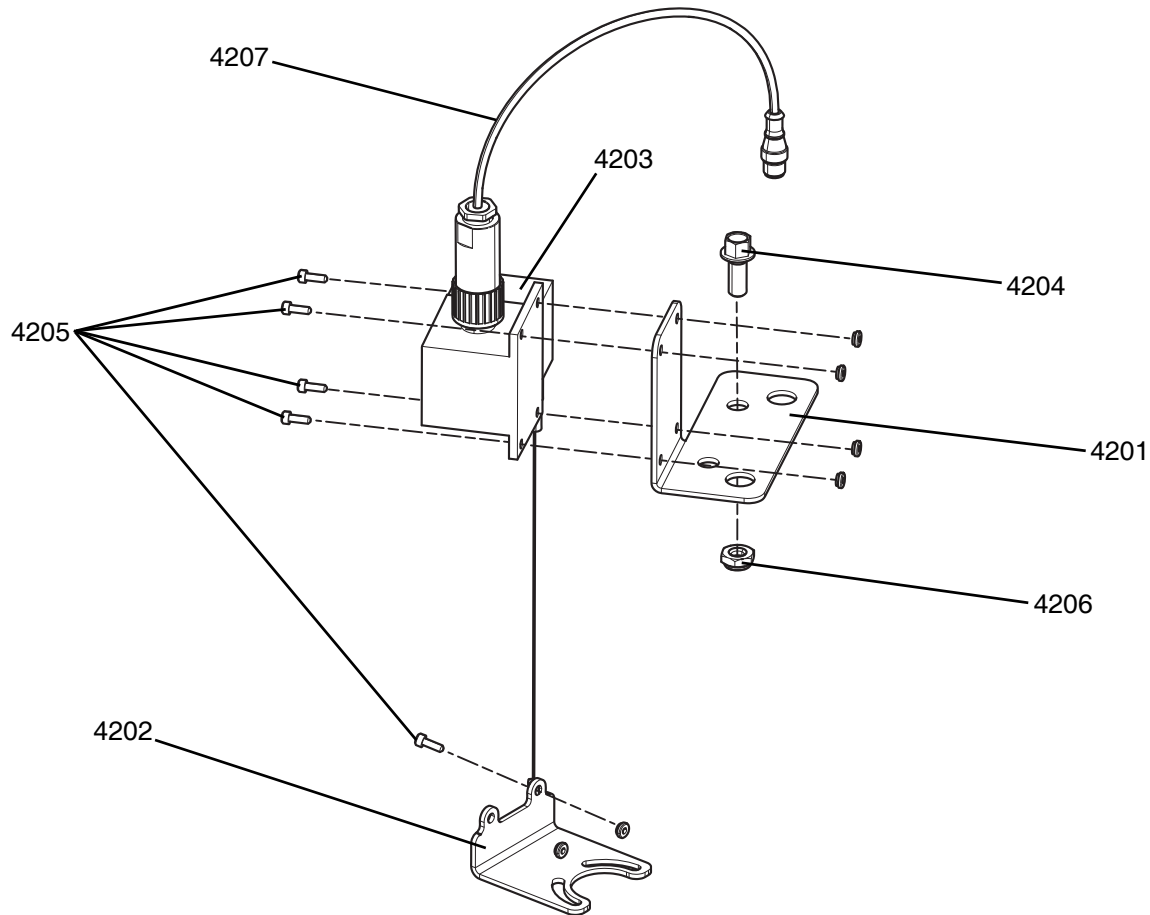

FIG. 43: Continuous Level Sensor 25A101

Ref	Part	Description	Quantity
4201	25A328	BRACKET, sensor, assy, 5 gal, white	2
4202	25A345	BRACKET, string, sensor, white	2
4203	17E314	SENSOR, pot, string	2
4204	127048	SCREW, mach, hex, flange, m 10 x 1.5 x 2	2
4205	116475	SCREW, shcs, m 4 x 12	10
4206	109209	NUT, lock, hex	2
4207	17E317	CABLE, gca, 5p x 6p, mx	2

5-Gallon Pail Girdle, 25A160

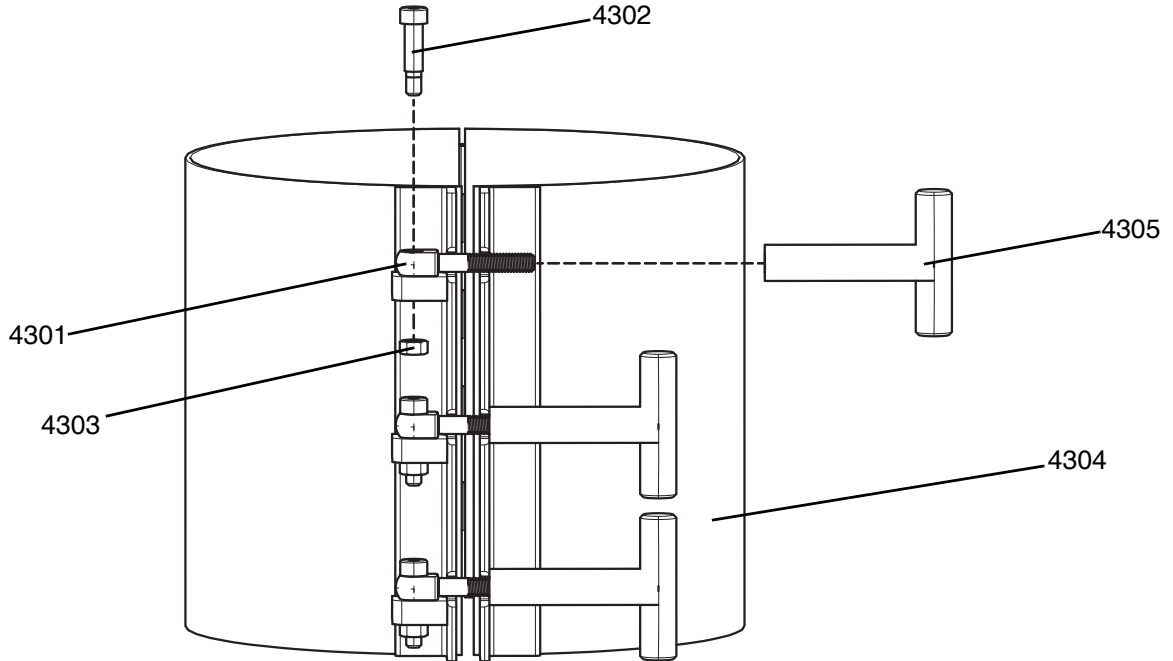

FIG. 44: Pail Girdle

Ref	Part	Description	Quantity
4301	FAA040220	ROD, jig latch bolt, 3/8-16 thds	3
4302	FAA040518	SCREW, shc, shldr, 3/8 x 1, ss	3
4303	FAA040540	NUT, hex, 5/16-18, cs, gr8, u-coat	3
4304	---	KIT, pail, girdle, weldment	1
4305	24R368	KIT, clamp, tee, handle	3

--- Not available for individual sale.

Pressure Transducer Kit, 25C237

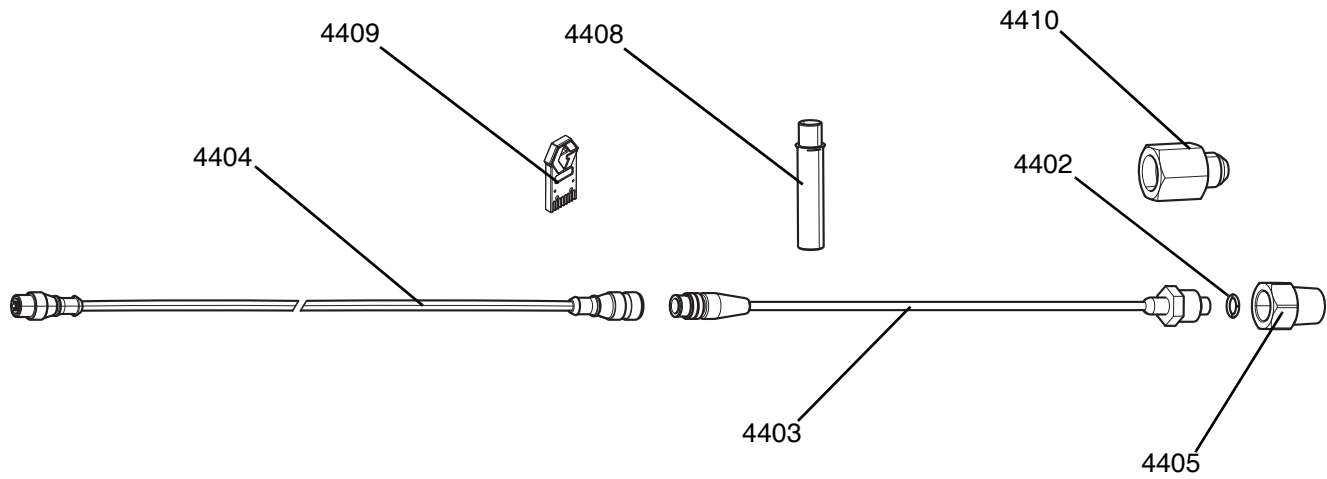

FIG. 45: Pressure Transducer

Ref	Part	Description	Quantity
4402	121399	PACKING, o-ring, 012 f x 75	2
4403	16A093	SENSOR, pressure, fluid outlet	2
4404	124409	CABLE, m12, 5 pin, rev key, m/f, 3m	2
4405	16G492	ADAPTER, pressure transducer, hlf	2
4407	128648✿	PROTECTOR, wire, corrugated, 1 in.	10 ft
4408	17M919	INSERT, restrictor, .078	2
4409	25C443	TOKEN, gca, key, lsr, small shot	1
4410	126975	FITTING, adapter, 1/2 nptf x 8 jicm, ss	2

✿Not shown.

Technical Data

Fluid Automation F4 Series		
Mixing Stacks: 25A990, 992, 993; 25A995, 997, 998; 25C792, 794, 799; Material Regulators: 25A892, 25A899; Material Filters: 25A909, 25A983		
	US	Metric
Maximum Operating Pressure - all except 25A983	3000 psi	241 bar, 24.1 MPa
Maximum Operating Pressure - 25A983	2610 psi	180 bar, 18.0 MPa
Maximum Air Pressure	145 psi	10 bar, 1 MPa
Maximum Coolant Pressure	100 psi	7 bar, 0.7 MPa
Viscosity range	50,000 to 5,000,000 cps	50,000 to 5,000,000 MPa-s
Wetted parts (fluid)	303/304 SST, 17-4 H1150 SST, acetal (POM), HDPE, UHMWPE, tungsten carbide, silicon nitride, flouroelastomer	
Wetted parts (coolant)	303/304 SST, nickel-plated brass, buna-n, acetal (POM), flouroelastomer, epoxy composite	
Inlet/Outlet Sizes		
Fluid Inlet (Mixing Stacks)	12 JIC(m)	
Fluid Outlet (Mixing Stacks)	06 JIC(m) - 25C792, 794, 799	
	08 JIC(m) - all others listed above	
Fluid Inlet/Outlet (Material Regulators)	08 JIC(f)	
Coolant Inlet/Outlet (Mixers)	5/16 in tube	8 mm tube

Graco Standard Warranty

Graco warrants all equipment referenced in this document which is manufactured by Graco and bearing its name to be free from defects in material and workmanship on the date of sale to the original purchaser for use. With the exception of any special, extended, or limited warranty published by Graco, Graco will, for a period of twelve months from the date of sale, repair or replace any part of the equipment determined by Graco to be defective. This warranty applies only when the equipment is installed, operated and maintained in accordance with Graco's written recommendations.

This warranty does not cover, and Graco shall not be liable for general wear and tear, or any malfunction, damage or wear caused by faulty installation, misapplication, abrasion, corrosion, inadequate or improper maintenance, negligence, accident, tampering, or substitution of non-Graco component parts. Nor shall Graco be liable for malfunction, damage or wear caused by the incompatibility of Graco equipment with structures, accessories, equipment or materials not supplied by Graco, or the improper design, manufacture, installation, operation or maintenance of structures, accessories, equipment or materials not supplied by Graco.

This warranty is conditioned upon the prepaid return of the equipment claimed to be defective to an authorized Graco distributor for verification of the claimed defect. If the claimed defect is verified, Graco will repair or replace free of charge any defective parts. The equipment will be returned to the original purchaser transportation prepaid. If inspection of the equipment does not disclose any defect in material or workmanship, repairs will be made at a reasonable charge, which charges may include the costs of parts, labor, and transportation.

THIS WARRANTY IS EXCLUSIVE, AND IS IN LIEU OF ANY OTHER WARRANTIES, EXPRESS OR IMPLIED, INCLUDING BUT NOT LIMITED TO WARRANTY OF MERCHANTABILITY OR WARRANTY OF FITNESS FOR A PARTICULAR PURPOSE.

Graco's sole obligation and buyer's sole remedy for any breach of warranty shall be as set forth above. The buyer agrees that no other remedy (including, but not limited to, incidental or consequential damages for lost profits, lost sales, injury to person or property, or any other incidental or consequential loss) shall be available. Any action for breach of warranty must be brought within two (2) years of the date of sale.

GRACO MAKES NO WARRANTY, AND DISCLAIMS ALL IMPLIED WARRANTIES OF MERCHANTABILITY AND FITNESS FOR A PARTICULAR PURPOSE, IN CONNECTION WITH ACCESSORIES, EQUIPMENT, MATERIALS OR COMPONENTS SOLD BUT NOT MANUFACTURED BY GRACO. These items sold, but not manufactured by Graco (such as electric motors, switches, hose, etc.), are subject to the warranty, if any, of their manufacturer. Graco will provide purchaser with reasonable assistance in making any claim for breach of these warranties.

In no event will Graco be liable for indirect, incidental, special or consequential damages resulting from Graco supplying equipment hereunder, or the furnishing, performance, or use of any products or other goods sold hereto, whether due to a breach of contract, breach of warranty, the negligence of Graco, or otherwise.

FOR GRACO CANADA CUSTOMERS

The Parties acknowledge that they have required that the present document, as well as all documents, notices and legal proceedings entered into, given or instituted pursuant hereto or relating directly or indirectly hereto, be drawn up in English. Les parties reconnaissent avoir convenu que la rédaction du présente document sera en Anglais, ainsi que tous documents, avis et procédures judiciaires exécutés, donnés ou intentés, à la suite de ou en rapport, directement ou indirectement, avec les procédures concernées.

Graco Information

Sealant and Adhesive Dispensing Equipment

For the latest information about Graco products, visit www.graco.com.

For patent information, see www.graco.com/patents.

TO PLACE AN ORDER, contact your Graco distributor, go to www.graco.com and select "Where to Buy" in the top blue bar, or call to find the nearest distributor.

If calling from the US: 800-746-1334

If calling from outside the US: 0-1-330-966-3000

All written and visual data contained in this document reflects the latest product information available at the time of publication. Graco reserves the right to make changes at any time without notice.

For patent information, see www.graco.com/patents.

Original instructions. This manual contains English. MM 3A3103

Graco Headquarters: Minneapolis

International Offices: Belgium, China, Japan, Korea

GRACO INC. AND SUBSIDIARIES • P.O. BOX 1441 • MINNEAPOLIS MN 55440-1441 • USA

Copyright 2015, Graco Inc. All Graco manufacturing locations are registered to ISO 9001.

www.graco.com

Revision J, April 2018