

Operation, Repair, and Parts



EcoQuip Vapor Abrasive

Blast System

334667F
EN

Vapor abrasive blast system. For professional use only.



Important Safety Instructions

Read all warnings and instructions in this manual. Save these instructions.

125 psi (8.6 bar, 0.86 MPa) Maximum Working Pressure

See page 3 for Model information.

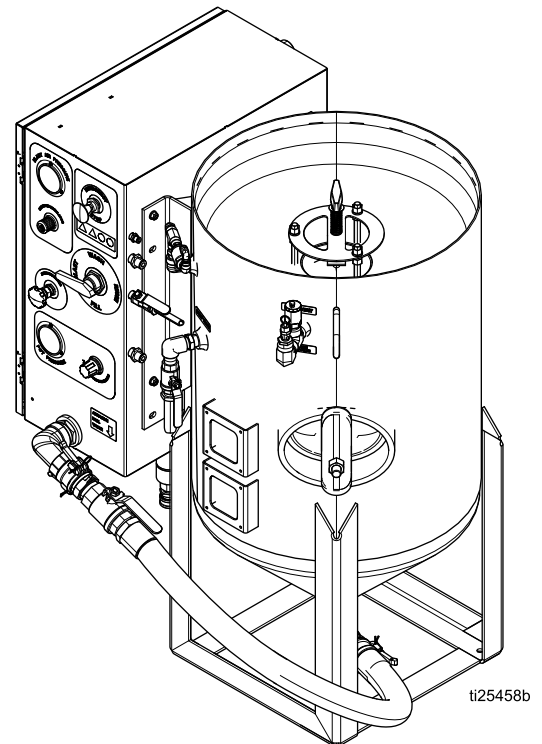



PROVEN QUALITY. LEADING TECHNOLOGY.

Contents

Models	3	Repairing the Diaphragm Valve	31
Related Manuals	3	Cleaning the Auto-Vent Valve	32
Warnings	4	Replacing the DataTrak Battery	33
OEM System Guidelines	7	Replacing the DataTrak Fuse	34
System Component Identification	8	Notes	35
EQ300C and EQ600C	8	Parts	36
DataTrak Controls	9	EQ300C and EQ600C	36
Pressure Relief Procedure	10	Enclosure	38
Grounding (ATEX Systems only)	10	Pressure Pot	40
Operation	11	Blast Hoses	41
Important Note	11	Hose Schematic	42
Checklist Before Starting	11	Vapor Abrasive Blast Systems and Accessories	43
Lifting the System	11	EcoQuip System Configurator	43
Connecting the Blast Hose and Air Hose	12	Model Series	44
Setting Up the Equipment	13	Blast Hoses with Control Hose/Cables	45
Blasting Tips	17	Blast Hoses without Control Hose/Cables	45
Using the Wash Feature	19	Blast Control Hoses/Cables	46
Refilling the Pot with Abrasive	20	Nozzles	46
Shutting Down	21	Other Accessories	46
Winterizing the Equipment	23	Common Spare Parts	47
Troubleshooting	24	Dimensions	48
Troubleshooting Examples	27	Technical Specifications	49
Repair	29	Graco Extended Warranty for EcoQuip™	50
Repairing the Main Air Regulator	29	Components	50
Flushing the Diaphragm Valve	30		

Models



Part	Description	Approvals
EQ300C	EcoQuip 300 Vapor Blast System	CE
EQ600C	EcoQuip 600 Vapor Blast System	CE
EQ30XC	EcoQuip 300 Vapor Blast system ATEX Approved	CE  II 2G c ia IIA T3 X
EQ60XC	EcoQuip 600 Vapor Blast System ATEX Approved	CE  II 2G c ia IIA T3 X

Related Manuals

Manual Number	Product
313840	DataTrak
333397	Pump
335035	Air Inlet Kit
334143	EQ300S, EQ600S
334142	EQ100M
334666	EQ200T, EQ400T



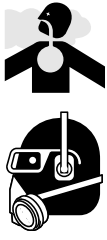

Warnings

The following warnings are for the setup, use, grounding, maintenance, and repair of this equipment. The exclamation point symbol alerts you to a general warning and the hazard symbols refer to procedure-specific risks. When these symbols appear in the body of this manual or on warning labels, refer back to these Warnings. Product-specific hazard symbols and warnings not covered in this section may appear throughout the body of this manual where applicable.

 WARNING	
	<p>SPECIAL CONDITIONS FOR SAFE USE</p> <ul style="list-style-type: none">• Ground all equipment in the work area. See Grounding Instructions.• All label and marking material must be cleaned with a damp cloth (or equivalent).
	<p>DUST AND DEBRIS HAZARD</p> <p>Use of this equipment can result in the release of potentially harmful dust or toxic substances from the abrasive being used, the coatings being removed, and the base object being blasted.</p> <ul style="list-style-type: none">• For use only by sophisticated users familiar with applicable governmental safety and industrial hygiene regulators.• Use equipment only in a well-ventilated area.• Wear a properly fit-tested and government approved respirator suitable for the dust conditions.• Follow local ordinances and/or regulations for disposal of toxic substances and debris.



WARNING

  <p>MPa / bar / PSI</p>	<p>EQUIPMENT MISUSE HAZARD</p> <p>Misuse can cause death or serious injury.</p> <ul style="list-style-type: none"> • Do not operate the unit when fatigued or under the influence of drugs or alcohol. • Do not exceed the maximum working pressure or temperature rating of the lowest rated system component. See Technical Data in all equipment manuals. • Do not use this equipment without hose restraints and coupler pins installed on all air and blast hose couplings. • Do not blast unstable objects. The high amount of fluid flow from the nozzle can potentially move heavy objects. • Do not exceed load rating of lift eyes. • Do not operate equipment on or stand on an unstable support. Keep effective footing and balance at all times. • Use fluids and solvents that are compatible with equipment wetted parts. See Technical Data in all equipment manuals. Read fluid and solvent manufacturer's warnings. For complete information about your material, request MSDS from distributor or retailer. • Do not leave the work area while equipment is energized or under pressure. • Turn off all equipment and follow the Pressure Relief Procedure when equipment is not in use. • Check equipment daily. Repair or replace worn or damaged parts immediately with genuine manufacturer's replacement parts only. • Do not alter or modify equipment. Alterations or modifications may void agency approvals and create safety hazards. • Make sure all equipment is rated and approved for the environment in which you are using it. • Use equipment only for its intended purpose. Call your distributor for information. • Route hoses and cables away from traffic areas, sharp edges, moving parts, and hot surfaces. • Do not kink or over bend hoses or use hoses to pull equipment. • Keep children and animals away from work area. • Comply with all applicable safety regulations.
	<p>BURN HAZARD</p> <p>Equipment surfaces and fluid that is heated can become very hot during operation. To avoid severe burns:</p> <ul style="list-style-type: none"> • Do not touch hot fluid or equipment.
	<p>FIRE AND EXPLOSION HAZARD</p> <p>Flammable fumes, such as solvent, in work area can ignite or explode. To help prevent fire and explosion:</p> <ul style="list-style-type: none"> • Use equipment only in well ventilated area. • Abrasive material exiting blast nozzle can generate sparks. When flammable liquids are used near the blast nozzle or for flushing or cleaning, keep the blast nozzle at least 20 feet (6 meters) away from explosive vapors. • Keep work area free of debris, including solvent, rags and gasoline. • Keep a working fire extinguisher in the work area.

 **WARNING**



PERSONAL PROTECTIVE EQUIPMENT

Wear appropriate protective equipment when in the work area to help prevent serious injury, including eye injury, hearing loss, inhalation of toxic fumes, and burns. Protective equipment includes but is not limited to:

- Protective eye wear and hearing protection
- Protective clothing, shoes, and gloves
- Properly fit-tested and government approved respirator suitable for the dust conditions



RECOIL HAZARD

Blast nozzle may recoil when triggered. If you are not standing securely, you could fall and be seriously injured.

OEM System Guidelines

	U.S.	Metric
System Weight (Dry)	450 lb	204 kg
System Weight (Wet)	1600 lb	726 kg
Water Tank Size (must be water compatible)	100 gallon (recommended)	378 liter (recommended)
Pump Inlet Fitting	Dixon 6EM6-B quick disconnect interchange included (3/4" NPT also on pump)	
Minimum ID	3/4 in.	1.9 cm
Maximum Recommended Pump Inlet Hose Length	5 ft	4.5 m
Maximum recommended rise from water tank outlet to pump inlet	16 in.	41 cm
Available Graco water inlet hoses (w/ quick disconnect interchanges)		
17C032	19 in. length	48 cm
EQ1848	36 in. length	91 cm
Available Graco water tank shutoff valve assembly (3/4" NPT male to 6EM6-B quick disconnect)	EQ5131	EQ5131

For air inlet hose recommendations, see [Technical Specifications, page 49](#).

See [Vapor Abrasive Blast Systems and Accessories, page 43](#) for Graco recommended blast hoses and nozzles.

For system dimensions and mounting locations, see [Dimensions, page 48](#).

System Component Identification

EQ300C and EQ600C

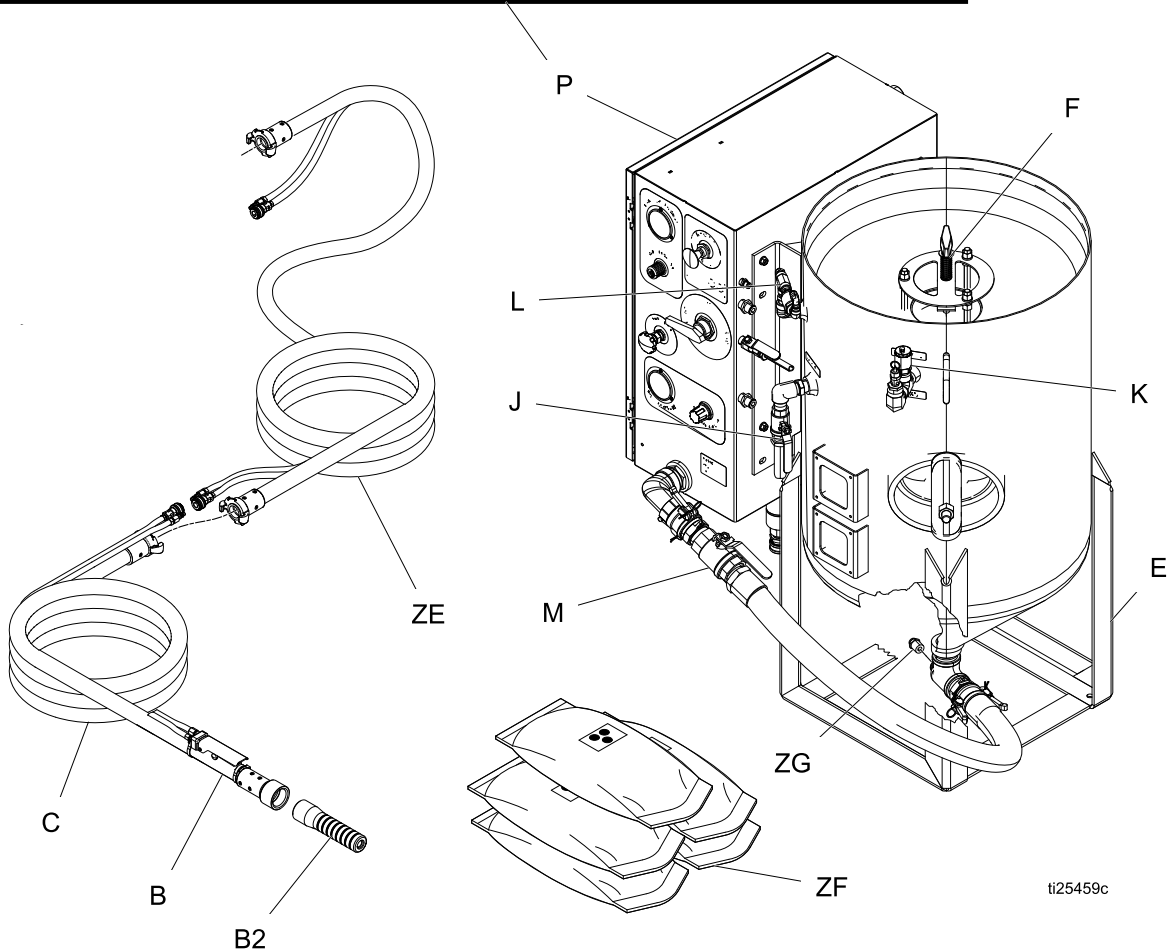
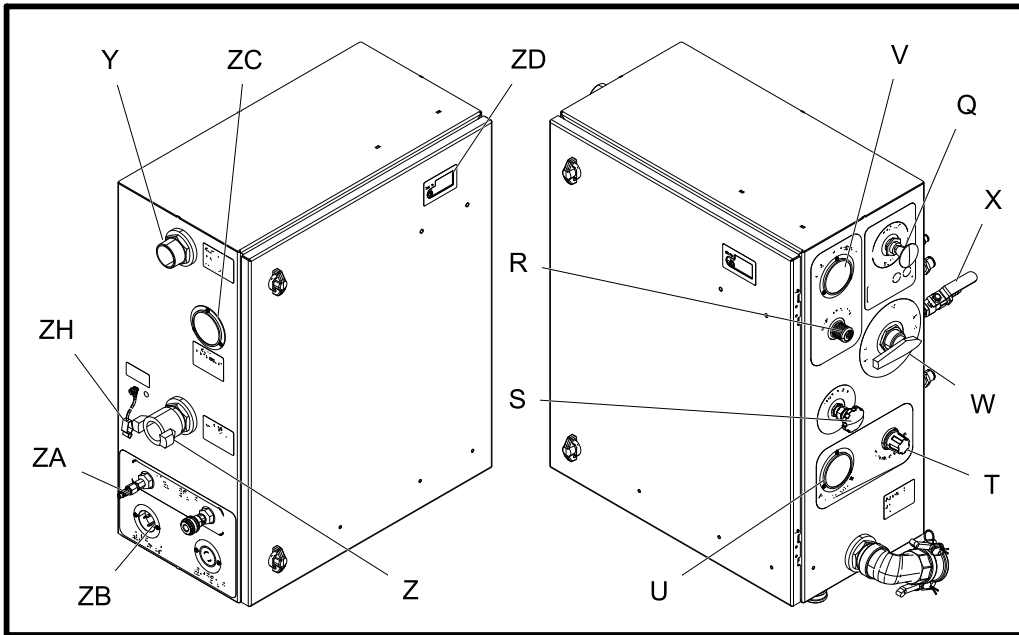

ti25459c

Key:

- A Cart
- B Blast Control Switch
- B2 Blast Nozzle
- C Blast Hose
- E Pot
- F Pop-Up Pin
- G Water Tank
- H Water Tank Lid
- J Pot Dump Valve
- K Auto Vent Valve
- L Blast Check Valve
- M Abrasive Ball Valve
- P Control Box
- Q Emergency Stop
- R Blast Air Regulator
- S Abrasive Metering Valve
- T Pot Pressure Regulator

Key:

- U Pot Pressure Gauge
- V Blast Air Pressure Gauge
- W Selector Valve
- X Rinse Ball Valve
- Y Air Supply Connection
- Z Blast Connection
- ZA Pneumatic Control Connection
- ZB Electric Control Connection (non-ATEX systems only)
- ZC Supply Air Pressure Gauge
- ZD DataTrak (see [DataTrak Controls, page 9](#))
- ZE Accessory Extension hose
- ZF Abrasive Media
- ZG Fill Port
- ZH Ground Wire and Clamp (ATEX Systems only)

DataTrak Controls

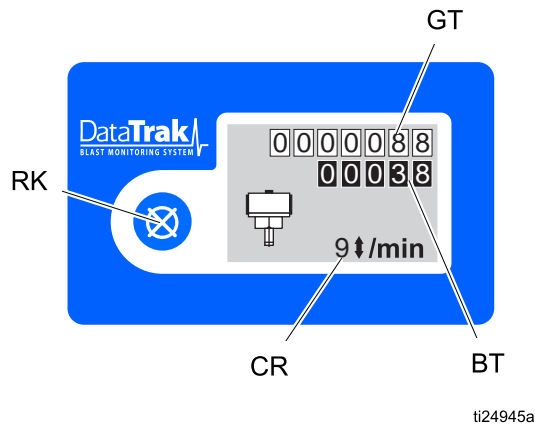

Key:

- RK Reset Key — Results in faults. Press and hold for three seconds to clear the batch totalizer.
- CR Cycle/Rate
- BT Batch Totalizer
- GT Grand Totalizer

Pressure Relief Procedure



Follow the Pressure Relief Procedure whenever you see this symbol.

<p>This equipment stays pressurized until pressure is manually relieved. To help prevent serious injury from pressurized fluid, such as splashing fluid, follow the Pressure Relief Procedure when instructed.</p>					

1. Turn the pot pressure regulator (PR) off.

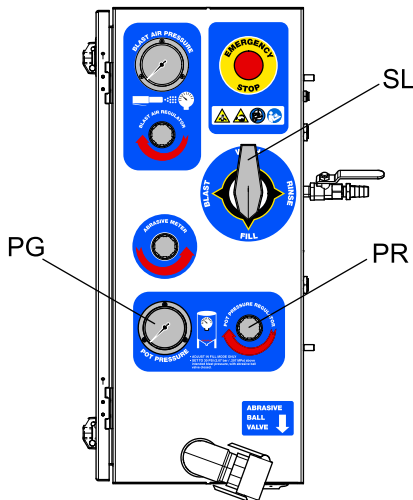

ti24111b

2. Close the abrasive ball valve.
3. Turn the compressor off. Close the compressor supply air valve.
4. Engage the blast control switch to relieve pressure in the system.
5. Verify that the air pressure gauge reads 0 psi. Then disconnect the air inlet hose from the system.

6. Turn the selector valve (SL) to FILL.
7. Open the dump valve.

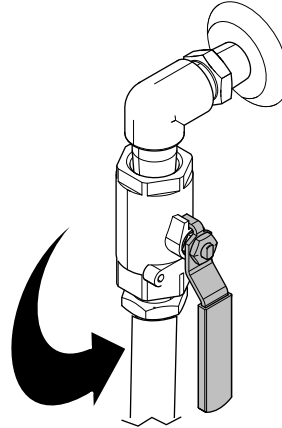

ti24112a

8. Verify that the pot pressure gauge (PG) displays zero pressure.

Grounding (ATEX Systems only)

<p>The equipment must be grounded to reduce the risk of static sparking. Static sparking can cause fumes to ignite or explode. Grounding provides an escape wire for the electric current.</p>					

Systems: Use supplied ground wire and clamp (237686).

Air and fluid hoses: Use only genuine Graco ATEX rated, conductive hoses with a maximum of 150 ft (45 m) combined hose length to ensure grounding continuity. Check the electrical resistance of the hoses. If the total resistance to ground exceeds 29 megaohms, replace the hose immediately.

Air compressor: follow manufacturer's recommendations.

Operation

Important Note

To prevent freezing, this equipment is shipped from the factory with blue windshield washer fluid inside the system. It is not necessary to drain before using. Dispose of the fluid in accordance with local regulations.

Checklist Before Starting

- Check the compressed air supply according to its operator manual. Make sure the air being supplied is clean and relatively free of moisture and oil to prevent water contamination of the air control components.
- Make sure air delivery valves are closed before the air supply compressor is started.
- Make sure all required hose restraints and coupler pins are in working condition and properly installed.
- Make sure the equipment is situated on level ground. Failure to keep the unit on level ground will make it difficult or impossible to purge all of the air from the pressure vessel.
- Make sure the equipment is properly supported on a surface that can hold its total weight. The weight of all personnel, the material being blasted, and any abrasive being stored must also be considered (see [Technical Specifications, page 49](#)).
- Make sure the water tank will remain fully supplied with clean water to avoid any possibility of the pump running dry during blasting.

- Make sure that the pot is clean and free of any internal debris.
- Make sure to use the correct type of blast control. An electric or pneumatic blast control switch can be used with hose lengths less than 150 ft (45 m). Blasting with 150 ft (45 m) or more of blast hose requires the use of an electric blast control switch.
- Make sure the blast hose is laid out as straight as possible between the equipment and the work site (a coiled blast hose will uncoil under pressure).

NOTICE

Sharp bends in the blast hose could cause the abrasive to wear through the hose and cause premature failure of the hose.

- Make sure the rubber gasket in each hose coupler is in working condition.

Lifting the System

- Lift the system with a lift apparatus rated appropriately for the weight of the system (see [Technical Specifications, page 49](#)).
- Do not lift the system by the lift rings on the pot.

Connecting the Blast Hose and Air Hose

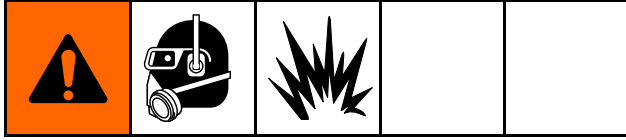

1. **EQ30XC and EQ60XC Models only:** Connect the grounding cable to the external ground stud (ZH) on the enclosure, then connect the clamp to a true earth ground.

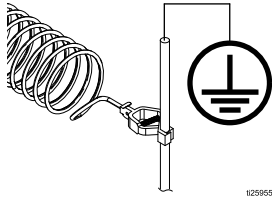

2. Always purge the air supply hose 15–20 seconds before connecting the air supply hose from the compressor (or on-site compressed air source) to the panel. Make sure all debris is cleared from the hose.

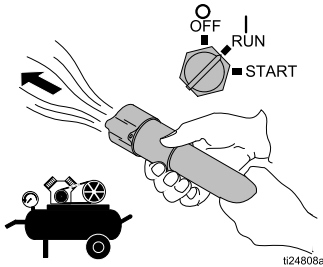

3. Connect an appropriately sized air supply hose to the air inlet. See [Technical Specifications, page 49](#).

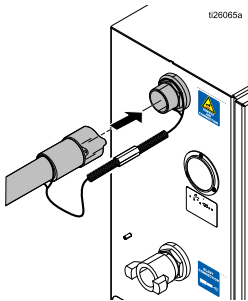

NOTE: Make sure to properly install hose restraints and coupler pins to the quick-coupler and the air line. If the holes on the quick-coupler do not align, there is something wrong and the two couplers are not compatible. **DO NOT TURN ON THE AIR.** Seek help to get the situation resolved.

4. Open the air supply valve (125 psi, 8.6 Bar, 0.86 MPa maximum). If necessary, use a regulator in the supply air line to meet these specifications.

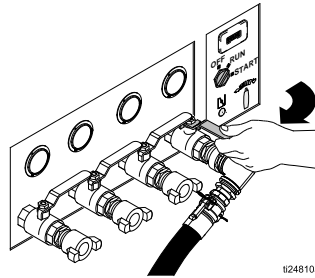

NOTE: Make sure the air supply meets the **appropriate air flow requirements**. See [Technical Specifications, page 49](#).

5. Connect the blast hose, hose restraints, control hoses, and coupler pins.

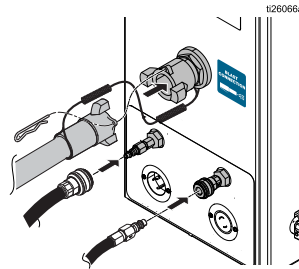

NOTE: If you are using an electric blast control, check all of the electrical connections from the panel to the blast control.

NOTICE

Make sure no electrical connections will be exposed to water. Exposure to water could cause a short circuit and damage the equipment.

Setting Up the Equipment

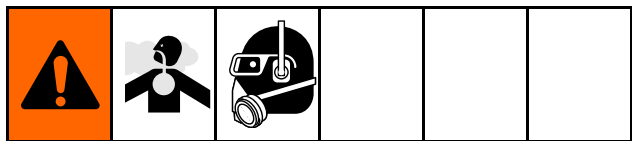

1. Disconnect the abrasive hose at the cam and groove with the abrasive ball valve closed.

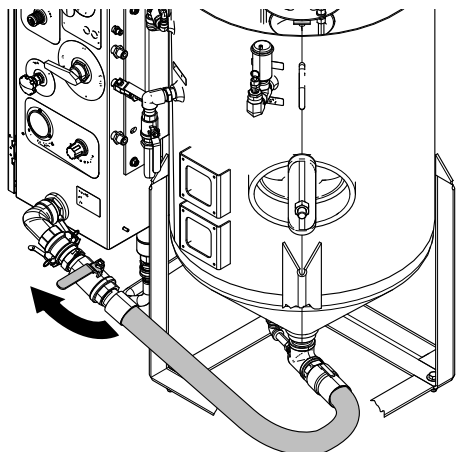

ti26067a

NOTE: If the pot contains water and abrasive (especially under pressure), releasing the cam and groove with the ball valve open will cause an unintentional release of abrasive.

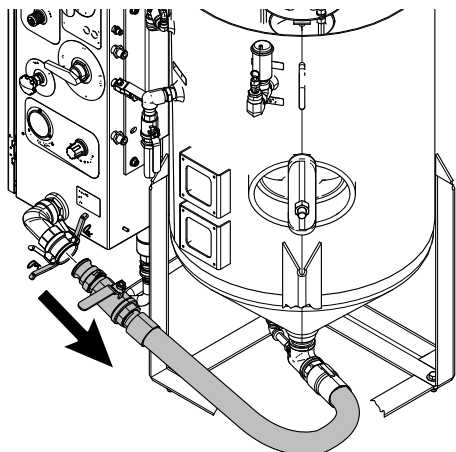

ti26068a

2. Flush water through the pot and out of the disconnected abrasive ball valve before filling the pot with water and abrasive.

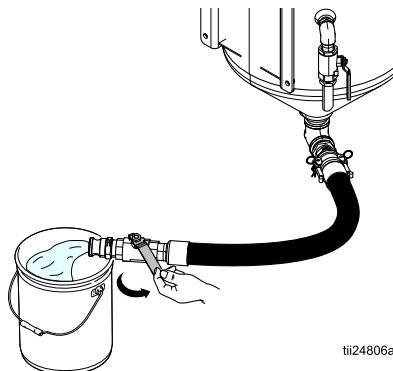

ti24806a

3. Reconnect the abrasive hose.
4. Disconnect the pump inlet hose and flush the water tank to remove any remaining debris. Reconnect the pump inlet hose.
5. Fill the water tank only with fresh water, then open the inlet ball valve.

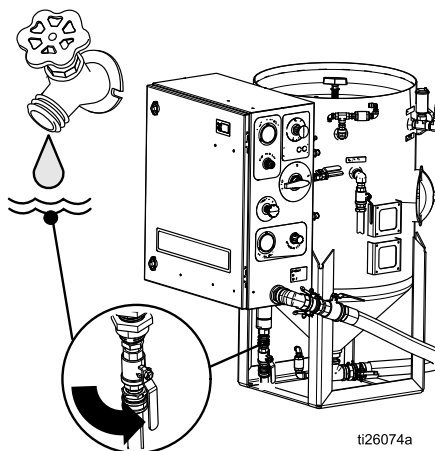

ti26074a

6. Close the rinse, dump, and abrasive ball valves.

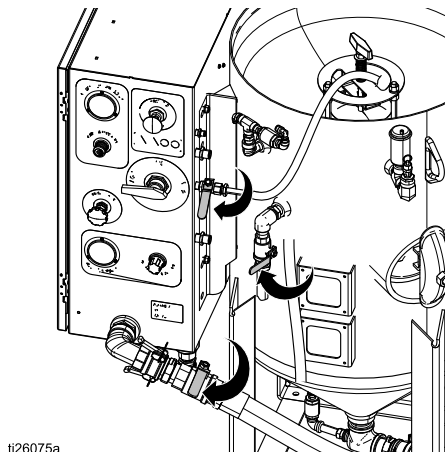

ti26075a

Operation

7. Turn the selector valve to RINSE.

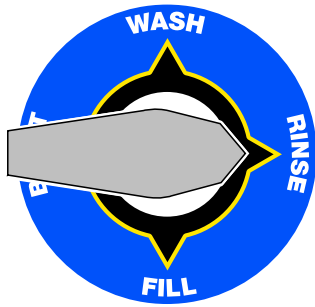

ti24143a

8. Disengage the Emergency Stop.

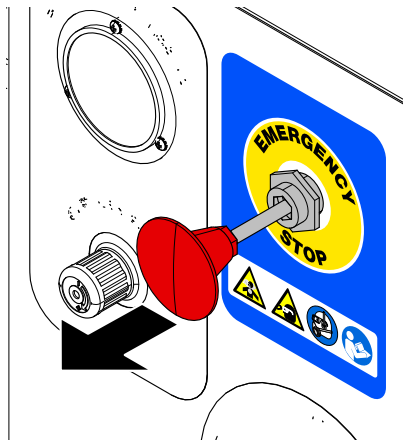

ti24813a

NOTE: The water pump will not work unless the Emergency Stop is disengaged.

9. Align the pop-up handle with the pin slot, and then firmly push and turn the handle 90° after the pin is below the bracket slot. Proper engagement of the pin will hold the pop-up down until it is released.

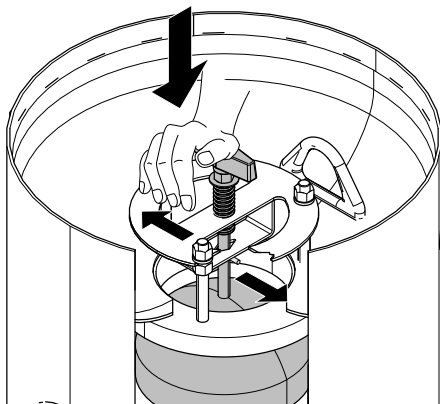

ti24701b

10. Add 10 gallons (30 liters) of fresh water to the pot. Wear appropriate personal protective equipment, including an appropriately fit-tested government approved respirator suitable for the dust conditions. Add abrasive material (minimum four bags, maximum ten 50 lb (23 kg) bags of high-mass abrasive, or eight 50 lb (23 kg) bags of low mass abrasive).

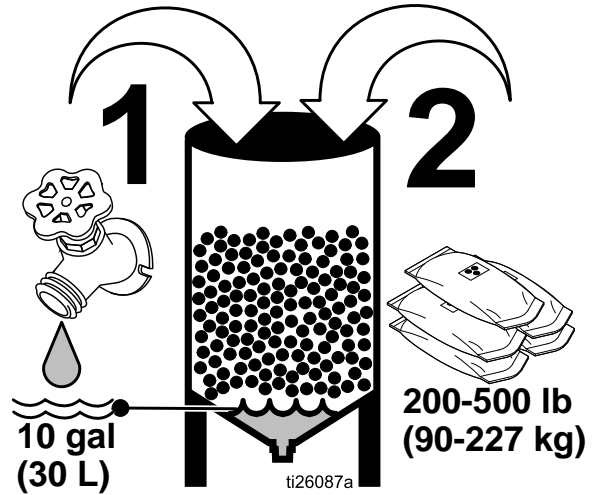

ti26087a

11. Use a garden hose or the rinse hose to wash the abrasive into the pot and clear any abrasive from the pop-up and gasket.
12. When the water level reaches the pop-up gasket, rotate the handle to release the pop-up pin.

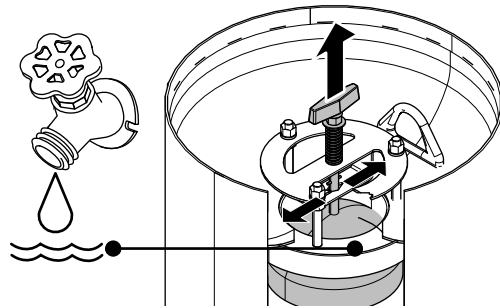

ti24811b

NOTE: Make sure pop-up gasket is clean of all debris.

13. Turn the selector valve to FILL.



ti24141a

NOTE: The water pump should begin cycling. If not, open the pot pressure regulator enough to cause the pump to run at 60 cpm.

NOTE: The auto vent/purge valve will allow all of the air trapped in the top of the pot to vent. When air stops venting, the pot pressure gauge will start to register pressure.

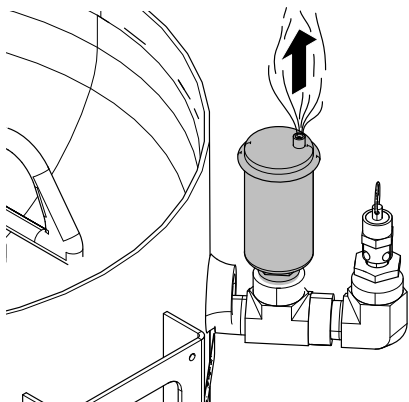

ti24930a

14. Wait for pot pressure to increase.

NOTE: It can take up to several minutes for the pot to pressurize.

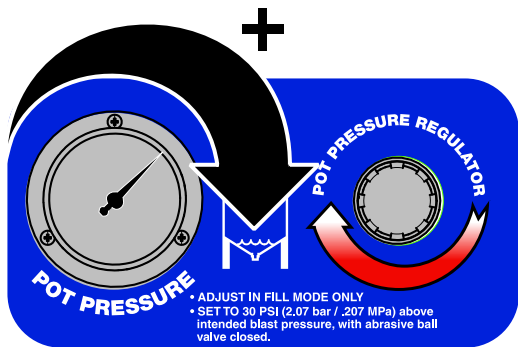

ti24824a

NOTE: The pop-up cannot be pushed down unless all of the pressure in the pot is released by opening the dump valve.

15. Set the pot pressure 30 psi (2.0 Bar, 0.2 MPa) higher than the intended blast pressure. Open and close the dump valve after the pump stalls. Relieve pot pressure to 40 psi (2.7 Bar, 0.27 MPa) before closing the dump valve. Repeat until pot pressure is consistent.

16. Turn the selector valve to WASH.

17. Set the blast air pressure 30 psi (2.0 Bar, 0.2 MPa) lower than the pot pressure while blasting.

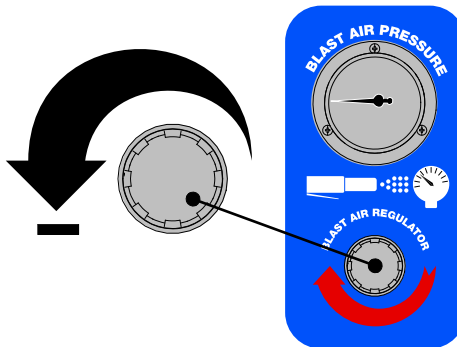

ti24147a

NOTE: In order to adjust the blast pressure, the blast control switch must be engaged. For the initial setting, leave the abrasive ball valve closed.

NOTE: Engage and release the blast control switch each time the blast regulator is adjusted.

18. Turn the selector valve to BLAST.

19. Open the abrasive ball valve.

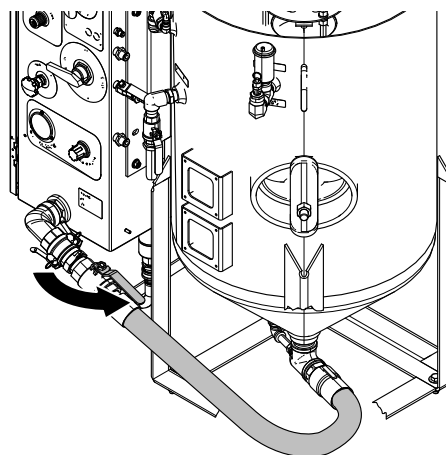

ti26069a

NOTE: Make sure the pot pressure returns to the initial setting (it will not return to the initial setting if the abrasive metering valve is closed).

Operation

20. Engage the blast control switch and begin blasting.

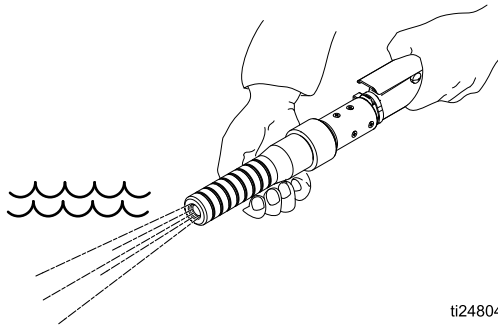

ti24804a

NOTE: You may have to wait 1–2 minutes for the abrasive material to reach the nozzle.

NOTE: Pot pressure and blast pressure should equalize during blasting. Only set pot pressure with the abrasive ball valve closed. Never adjust pot pressure while blasting.

21. Slowly adjust the abrasive meter valve while the abrasive is blasting from the nozzle. Typical adjustment ranges from 1/8 to 1/4 turn open.

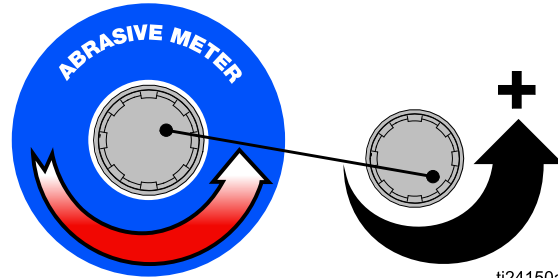

ti24150a

NOTE: The DataTrak can be used to assist in setting the pump cycle rate. Optimal abrasive media consumption typically occurs with the cycle rate set at 7–10 cycles per minute.

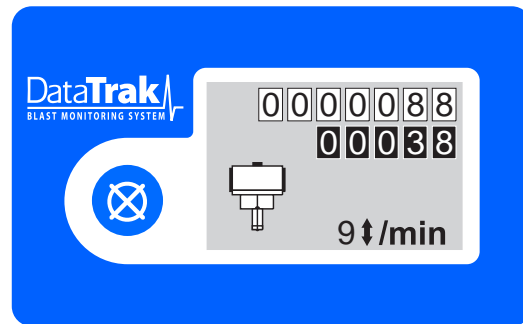

ti24154a

NOTE: Use a piece of test material similar to what you will be blasting.

NOTE: Always start as gently as possible and then increase the blast force as necessary to clean without doing any damage to the substrate. When properly set, the pump should cycle 7-10 times per minute. High production rate users may need to increase cycle rate above 10 cycles per minute.

NOTE: Close the abrasive ball valve whenever you stop blasting for more than 20-30 minutes. This will help to extend the service life of the diaphragm valve.

Blasting Tips

When first learning the effects of the blaster, get a better understanding of the results by starting at a shallow angle (closer to 0° than to 90°) and keep the nozzle approximately 16 in. (40 cm) from the application. Observe the results, then reduce the distance, steepen the angle, and adjust the blast regulator.

As the blast pressure is increased, slowly adjust the abrasive metering valve and watch the DataTrak to achieve 7-10 pump cycles per minute. See [DataTrak Controls, page 9](#).

NOTE: The heavier and smaller the abrasive particle (i.e. 80-grit), the more aggressive the results.

Blasting on Higher Surfaces

When blasting on a surface higher than the equipment, make sure that there is a length of blast hose on the ground equal to 10-20% of the height. The hose on the ground prevents unspent abrasive in the hose from back-filling the internal plumbing of the panel.

For example: When blasting 50 feet (15 m) straight up, use at least 10 feet (3 m) of blast hose on the ground before the blast hose goes up to the blasting height.

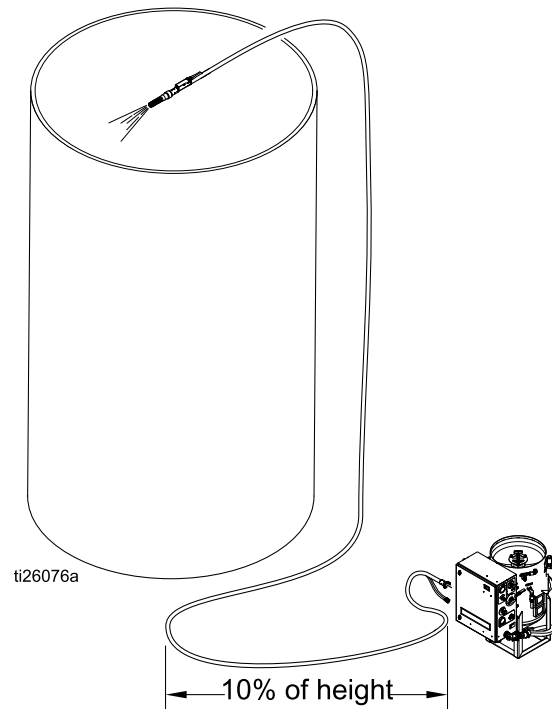

Abrasive Metering Valve Settings

There is no fixed formula for what works best in each application. The information below works best for the majority of the time. From this initial setting, adjustments can be made up or down to get the fastest removal rates without damage to the surface.

Normal settings are: 110 psi (7.5 Bar, 0.75 MPa) initial pot setting, less than 1/2 turn open metering valve, blasting pressure at 80 psi (5.5 Bar, 0.55 MPa). For applications requiring higher performance, use high-performance abrasive (the heaviest mass @ 80 grit) such as Garnet, and the highest pressures the system can support. The initial pot pressure should always be 30 psi (2.0 Bar, 0.2 MPa) above the intended blast pressure.

Gradually make adjustments to meet the specific requirements for each application. Make adjustments (see [DataTrak Controls, page 9](#)) to achieve 7-10 cycles per minute to be the most efficient (cut at the fastest rate while using the least amount of abrasive). Blasting pressures can range between 30 - 120 psi max (2.0 Bar, 0.2 MPa – 8.2 Bar, 0.82 MPa).

Unlike conventional sandblasting, higher pressures do not necessarily mean better cleaning. Nozzle distance and the angle to the surface has an effect on performance, as does the blast pressure. Choice of abrasive also has a great effect. High-performance abrasive produces the best performance and can save enough time to make up the difference in cost.

NOTE: Blasting with 150 ft (45 m) or more blast hose requires the use of an electric blast control.

	Grit Size	Blast Pressure	Abrasive Metering Valve	Blast Angle	Notes
General	40/70 crushed glass	60-80 psi (4.1 Bar, 0.41 MPa - 5.5 Bar, 0.55 MPa)	10 cycles per minute	35° - 65°	None
Wood	80 (using a low mass abrasive like crushed glass or walnut)	40-50 psi (2.7 Bar, 0.27 MPa - 3.4 Bar, 0.34 MPa)	8 cycles per minute	15° - 30°	Do not wash, as it may raise the wood grain. Brush off excess abrasive after the wood dries.
Steel	60-80 (using a high-mass abrasive like Garnet)	100-120 psi (6.8 Bar, 0.68 MPa - 8.2 Bar, 0.82 MPa)	10-12 cycles per minute	45° - 65°	None
Fiberglass	40-70 low mass	45-65 psi (3.1 Bar, 0.31 MPa - 4.4 Bar, 0.44 MPa)	8 cycles per minute	35° - 45°	None

NOTE: Adjustment in blast pressure requires an adjustment of the abrasive metering valve.

Using the Wash Feature

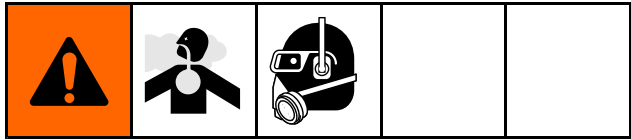

The wash feature causes air-driven water (without abrasive) to rinse areas that have already been blasted with abrasive. It is also a convenient feature for flushing abrasive from the blast hose.

NOTICE

There will always be some residual abrasive in the blast hose. Never use the wash feature on any surface other than where you have blasted, or intend to blast. It will affect/dull the surface.

NOTICE

Do not use the wash feature on wood that has been blasted. It could damage the wood and cause the grain to rise. Wait for the wood to dry and then use a broom, brush, or vacuum to remove any residual abrasive.

1. Close the abrasive ball valve.

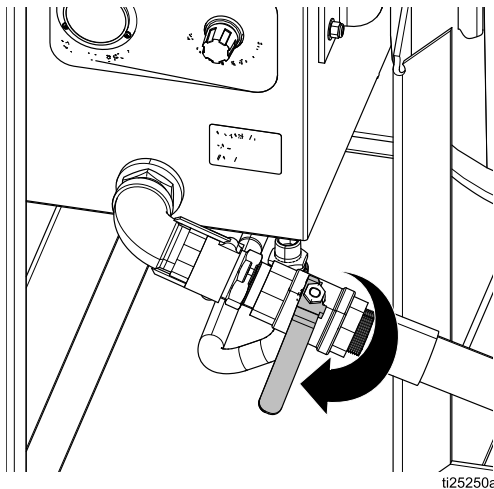

ti25250a

2. Turn the selector valve to WASH.



ti24142a

3. Blast 1 – 2 minutes until the abrasive is cleared from the hose.

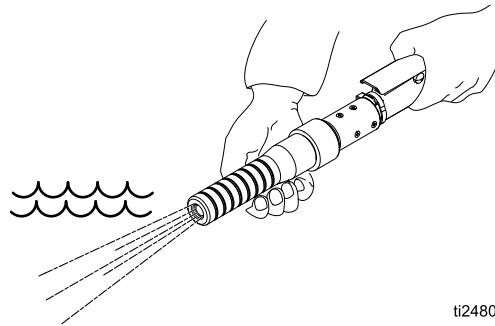

ti24804a

4. The equipment is now ready to wash any previously blasted surfaces.

Refilling the Pot with Abrasive

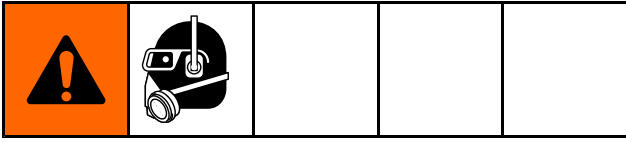

1. Close the abrasive ball valve.
2. Turn the selector valve to RINSE.

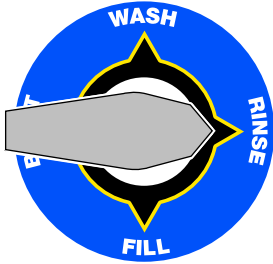

ti24143a

3. Open the dump valve slowly to relieve the water pressure in the pot.

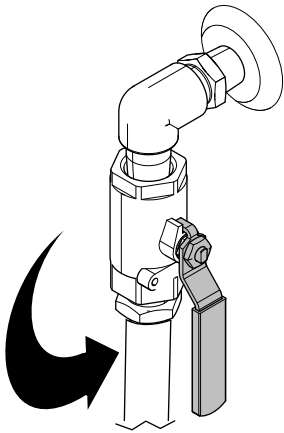

ti24112a

NOTE: Be prepared to capture the water that will be drained from the pot. All disposals must comply with national, state, and local regulations.

4. After all of the pressure in the pot has been relieved, engage the pop-up pin by compressing the spring and turning the handle 90° to hold the pop-up in the open position.

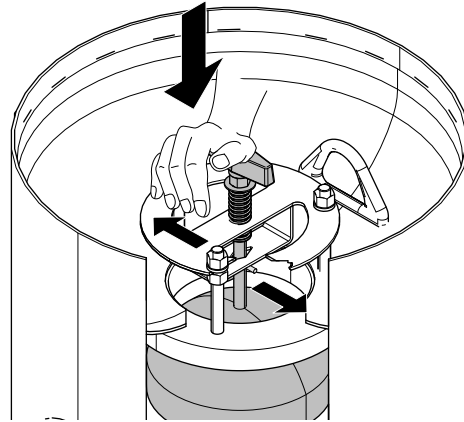

ti24701b

5. Add the abrasive (minimum four bags, maximum ten 50 lb (23 kg) bags of high-mass abrasive or eight 50 lb (23 kg) bags of low-mass abrasive) and continue the procedures from [Setting Up the Equipment, page 13](#).

NOTE: More water may need to be drained from the pot to allow additional abrasive to be added.

Shutting Down

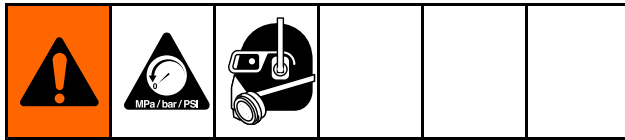

1. When you have finished blasting, perform wash until all of the abrasive is flushed from the blast hose. See [Using the Wash Feature, page 19](#).
2. Turn the selector valve to RINSE, and with the abrasive ball valve closed, continue to blast until water is cleared from the hose. This is to dry the inside of the hose for storage.

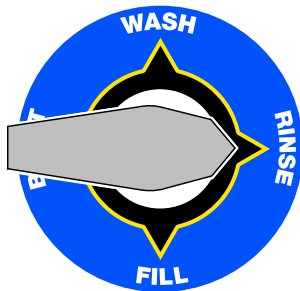

ti24143a

3. Open the abrasive ball valve, then open the dump valve until the pot pressure gauge reads 0 psi. Close the abrasive ball valve and dump valve.

NOTE: Short-term shutdown is now complete. If the unit will be shut down for more than 24 hours, proceed to the next step.

4. Disconnect the abrasive ball valve cam-lock by removing the coupler pins and pulling the rings out and up to pull the two cams away from the groove.

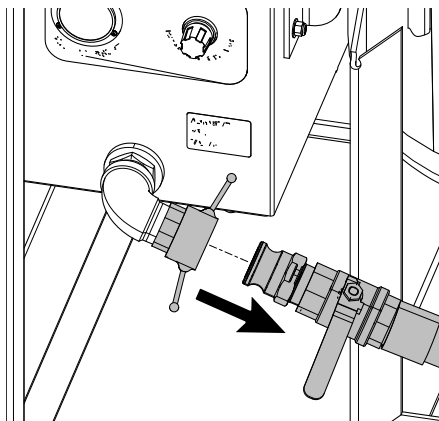

ti25252a

5. Hold a bucket under the cam-lock coupler, then turn the selector valve to WASH. This will clean debris from the cam-lock coupler and gasket.

NOTE: Make sure the gasket is clean and in place after the procedure.

NOTE: Be sure to catch the unspent abrasive that will be washed out of the panel plumbing.

6. Turn the selector valve to FILL. This will help push the abrasive out through the abrasive hose.
7. Place a bucket under the abrasive hose. Slowly open and close the abrasive ball valve to flush abrasive material from the pot. Repeat several times. Once no abrasive material flows from the hose, close the abrasive ball valve.

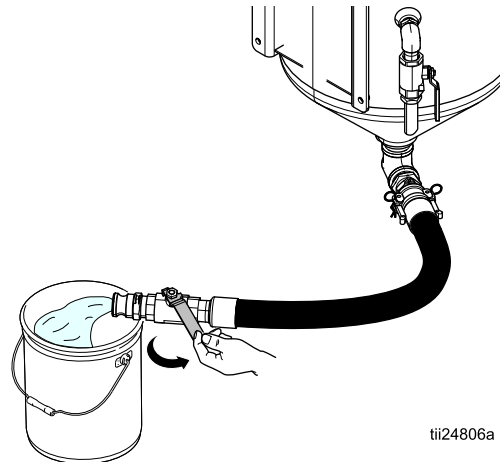

ti24806a

NOTE: Estimate that a 5 gallon pail will be needed for each bag of abrasive still in the pot. Cover the buckets during storage so debris does not contaminate the abrasive.

Operation

- Engage the pop-up pin to hold the pop-up open and allow air to enter.

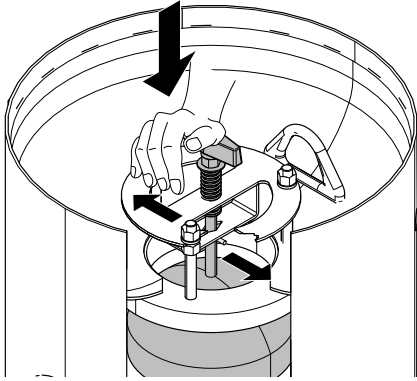

ti24701b

- Open the abrasive ball valve and flush the pot of any remaining abrasive material.

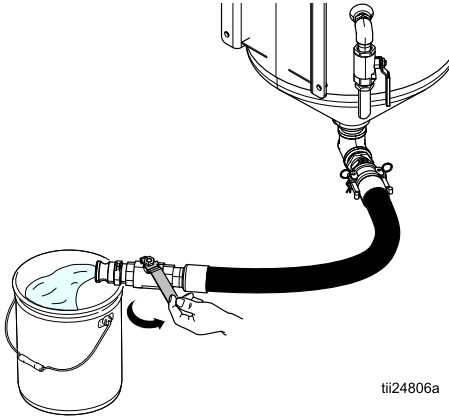

ti24806a

- Close the pop-up and connect the abrasive hose.

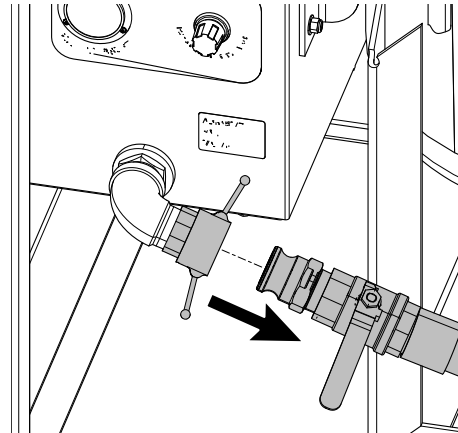

ti25252a

NOTE: The system must be winterized if it will be exposed to temperatures below freezing. See [Winterizing the Equipment, page 23](#).

- Relieve pressure to complete system shutdown (see [Pressure Relief Procedure, page 10](#)).

Winterizing the Equipment

Vapor-Abrasive Blasters must be winterized whenever there is a possibility of freezing temperatures during storage. It is imperative that you anticipate the possibility of a freeze and always protect the unit during fall and winter seasons, even if being stored only overnight.

1. Make sure all of the water has been drained from the pot. Reconnect the abrasive hose after draining the pot.

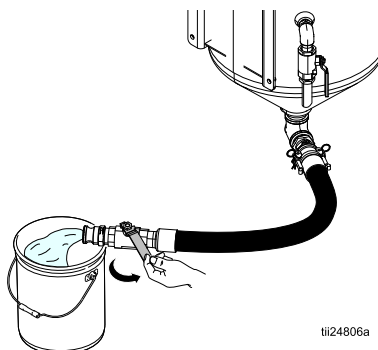

2. Make sure the pop-up is in the closed position. This will prevent debris from entering the pot during storage.
3. Drain the water tank by disconnecting the pump inlet hose and opening the inlet ball valve.

NOTE: All disposals must comply with national, state, and local regulations. In addition, if the water contains a rust inhibitor, you may want to retain and preserve the water due to the expense of the inhibitor.

4. Drain the pump inlet hose, then insert the end into a windshield wash container. Choose a windshield wash with a rating that will protect the equipment for the lowest temperatures in your area.

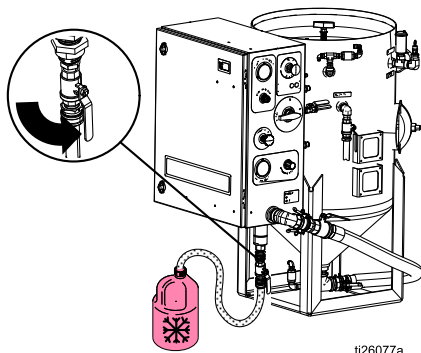

5. Turn the selector valve to RINSE and open the rinse ball-valve. While holding the rinse hose over the pot, run the pump until windshield wash comes out of the rinse hose.

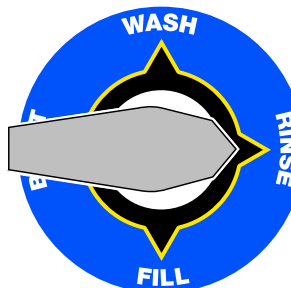

6. Move the selector valve into the other three positions (WASH, BLAST, and FILL). Confirm that the internal water tubing fills with windshield wash before turning the selector valve to the next position.

NOTE: All 3/8 in. tubing should be filled with windshield wash for full protection.

7. Engage the Emergency Stop.
8. Reconnect the pump inlet hose to the inlet ball valve.
9. Make sure that the rinse ball-valve and the drain ball-valve are left open.

NOTICE

When ice forms behind the seals, the seals can become damaged. During storage, position all ball-valves in the open position.

Troubleshooting

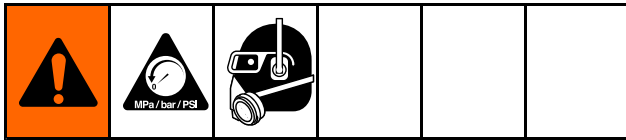

Problem	Cause	Solution
The pot will not properly pressurize.	The air supply is inadequate.	Make sure the air inlet pressure gauge reads 100-125 psi (6.8–8.6 bar, 0.68–0.86 MPa). If the gauge does not read 100–125 psi, check the air compressor for proper setup.
	The Emergency Stop is engaged.	Disengage the Emergency Stop.
	Inadequate water supply to the pump.	Make sure the water tank is full and the inlet ball valve is open.
	The pot pressure regulator is set too low.	Increase the setting on pot pressure regulator.
	The pop-up cannot seal properly.	Clean all abrasive from the pop-up and gasket. Make sure the pop-up spring is lifting and the pop-up is firmly against the gasket. If cleaning does not solve issue, replace the pop-up gasket.
	The Auto-Vent valve will not seal.	See Cleaning the Auto-Vent Valve, page 32 .
	The pot pressure relief valve is discharging water.	Decrease the pot pressure to 145 psi (10.3 bar, 1.03 MPa) or less. If the valve weeps or relieves at 145 psi, replace valve.
	The pot or pump is leaking pressure.	Make sure the abrasive ball valve and the dump valve are closed. If pot pressure gauge still creeps downward. See Checking for Leaks, page 27 .
The pot pressure regulator is malfunctioning.	Replace the pot pressure regulator assembly.	
The blast pressure will not reach the desired set point.	The air supply is inadequate.	Make sure the air inlet pressure gauge reads 100-125 psi (6.8–8.6 bar, 0.68–0.86 MPa). If the gauge does not read 100–125 psi, check the air compressor for proper setup.
	The blast air regulator is malfunctioning.	Replace the blast air regulator.
	The main air regulator is malfunctioning.	See Repairing the Main Air Regulator, page 29 .

Problem	Cause	Solution
<p>No abrasive flows from the nozzle during blast mode.</p>	<p>The pot does not have a sufficient amount of abrasive.</p>	<p>See Refilling the Pot with Abrasive, page 20.</p>
	<p>The system is not properly set up.</p>	<p>See Setting Up the Equipment, page 13. Make sure the pot pressure is properly set. The pot pressure must be set 30 psi (2 bar, 0.2 MPa) above the blast pressure. Make sure the selector valve is set to BLAST. The abrasive ball valve must be open. The abrasive metering valve must be at least 1/8 turn open.</p>
	<p>There is an obstruction in the media circuit.</p>	<p>See Flushing the Diaphragm Valve, page 30.</p>
	<p>The diaphragm valve is not working.</p>	<p>See Repairing the Diaphragm Valve, page 31.</p>
	<p>There is blockage inside the pot or inside the abrasive hose between the pot and the panel.</p>	<p>Make sure the ball valve is closed, then disconnect the cam-lock coupler. Open the abrasive ball valve slightly and make sure abrasive is flowing from the abrasive hose. If not, follow the shut down procedure (see Shutting Down, page 21). Thoroughly flush the pot and the media hose after draining media and water.</p>
<p>No blast air flow when the blast control is engaged. The water pump cycles while the blast control engaged.</p>	<p>The blast regulator is not adjusted to the correct pressure.</p>	<p>Adjust the blast regulator to the desired pressure while the blast control is engaged.</p>
	<p>The tubing to the main air regulator is not properly connected.</p>	<p>Confirm that the tubing from the blast regulator to the main air regulator is intact. See Hose Schematic, page 42.</p>
	<p>The blast air regulator is malfunctioning.</p>	<p>Replace the blast air regulator.</p>
	<p>The main air regulator is malfunctioning.</p>	<p>See Repairing the Main Air Regulator, page 29.</p>
<p>No blast air flow when the blast control is engaged. The water pump does not cycle while the blast control engaged.</p>	<p>The air supply is inadequate.</p>	<p>Make sure the air inlet pressure gauge reads 100-125 psi (6.8–8.6 bar, 0.68–0.86 MPa). If the gauge does not read 100–125 psi, check the air compressor for proper setup.</p>
	<p>The Emergency Stop is engaged.</p>	<p>Disengage the Emergency Stop.</p>
	<p>The electric blast control circuit is malfunctioning.</p>	<p>Inspect the hose cable for damaged or shorted wiring. Check the battery and control panel connections. Make sure the DC power source is 12V. Check the 3A fuse inside the control panel, and replace it if necessary. Check the current flow in the circuit. If current exists, replace the relay.</p>
	<p>The pneumatic blast control circuit is malfunctioning.</p>	<p>See Pneumatic Blast Control Circuit, page 28.</p>

Troubleshooting

Problem	Cause	Solution
The blast control is not engaged but blasting still occurs.	The main air regulator is stuck open.	See Repairing the Main Air Regulator, page 29 .
	The blast control tubing is not connected properly.	Ensure air tubing is routed and connected properly. See Hose Schematic, page 42 .
	Electric blast control circuit is malfunctioning.	Inspect hose cable for damaged or shorted wiring. Check battery and control panel connections. Ensure DC power source is 12V. Check 3A fuse inside control panel and replace it if necessary. Check current flow in circuit, if current exists, replace relay.
	Pneumatic blast control circuit is malfunctioning.	See Pneumatic Blast Control Circuit, page 28 .
The blast spray pattern is irregular.	Incorrect abrasive is being used.	Use the correct abrasive. See Abrasive Metering Valve Settings, page 18 .
	The pot does not have a sufficient amount of abrasive.	Refill the pot with abrasive. See Refilling the Pot with Abrasive, page 20 .
	The pot pressure setting is incorrect.	Perform the pressure relief procedure (see Pressure Relief Procedure, page 10) and reset pot pressure (see Setting Up the Equipment, page 13).
	The Auto-Vent valve does not vent air when the pot is filled.	Make sure the Auto-Vent valve is working. Perform the Auto-Vent cleaning procedure (see Cleaning the Auto-Vent Valve, page 32).
	The diaphragm valve is malfunctioning.	Perform the diaphragm flush procedure (see Flushing the Diaphragm Valve, page 30). If flushing does not solve problem, see Repairing the Diaphragm Valve, page 31 .
	There is blockage inside the pot or inside the abrasive hose between the pot and the panel.	Make sure the ball valve is closed, then disconnect the cam-lock coupler. Open the abrasive ball valve slightly and make sure abrasive is flowing from the abrasive hose. If not, follow the shut down procedure (see Shutting Down, page 21). Thoroughly flush the pot and the media hose after draining media and water.
A strong hose recoil occurs frequently when the blast control switch is engaged.	The unit is not on a level surface.	Place the unit on a level surface. If this is impossible, the Auto-Vent must be on the higher side of the unit.
	The initial pot pressure is not set correctly.	Confirm that the auto-vent valve is working and set initial pot pressure 30 psi (2.0 bar, 0.2 MPa) above the blast pressure.
	The Auto-Vent is malfunctioning.	Perform auto-vent cleaning procedure (see Cleaning the Auto-Vent Valve, page 32).
	The diaphragm needs to be flushed.	Perform the diaphragm flush procedure (see Flushing the Diaphragm Valve, page 30). If flushing does not solve the problem, see Repairing the Diaphragm Valve, page 31 .

Troubleshooting Examples

Checking for Leaks

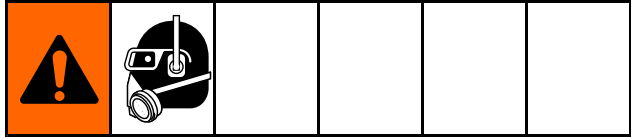

1. Open the dump valve. Check pot pressure gauge, then close the dump valve.

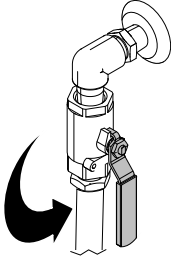

ti24112a

Look at the pressure gauge to confirm that all pressure has been relieved from the pot.



ti24825a

2. Disconnect the tubing at the blast check valve (L) and at the fill port check valve (ZG).

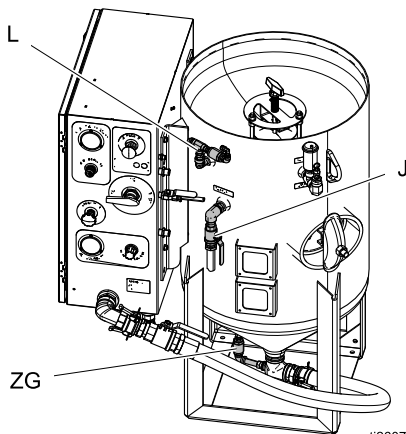

ti26078a

3. Make sure the pop-up is engaged with its seal. Turn the selector valve to WASH, then open the abrasive ball valve to pressurize the pot. Set the pot pressure to 145 psi (9.9 Bar, 0.99 MPa).



ti24142a

4. Check the water pump to confirm that no water is leaking from the TSL fill port.

NOTE: The pump should stall after the pot pressurizes. If the pump does not stall, replace the seals. Refer to the pump manual for repair information.

5. Check for any water leaking from either check valve. If a check valve is leaking, it must be repaired or replaced. If the valves are damaged, the pot will not be able to maintain pressure. Also, check the pot pressure relief valve. If the valve is weeping at pot pressures of 145 psi or less, it needs to be replaced.
6. Close the abrasive ball valve, close the air inlet ball valve, then engage the blast control switch to relieve pressure in the blast circuit. Confirm that the air supply pressure gauge reads 0 psi.
7. Disconnect the quick coupler and confirm that the ball valve is not leaking. Replace the abrasive ball valve if it is leaking.

Pneumatic Blast Control Circuit

1. At the Air-Relay, disconnect the push-to-connect tubing and check the trigger circuit (from the blast control handle).
2. With the blast control switch activated, confirm that there is air flowing from the disconnected tube.

NOTE: The air flow should be at supply air pressure but the air volume is reduced due to the size of the fittings and tubing. If you do not get supply air pressure, check the blast control switch for proper operation, and check the blast control hoses to make sure they are not kinked or internally blocked.

3. Check the in-line filter at the industrial interchange nipple connection on the side of the panel (where you attach the blast control hose).
4. If the previous steps do not fix the issue, replace the air relay.

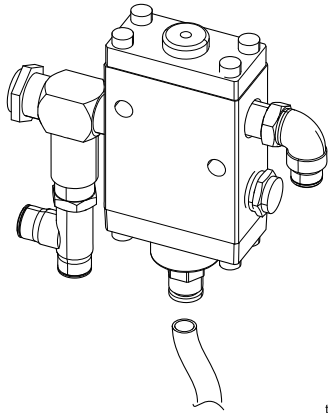

ti26052a

Pneumatic Blast Control — ATEX Approved

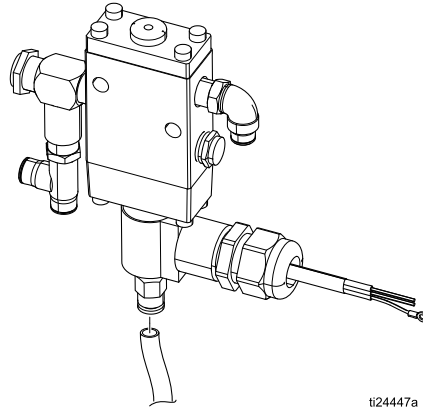

ti24447a

Electric/Pneumatic Blast Control

Repair

Repairing the Main Air Regulator

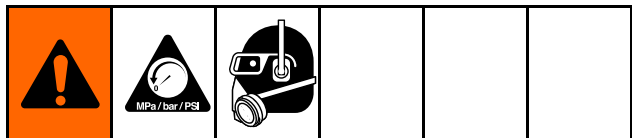

See [Enclosure Parts List, page 39](#) for repair kits.

1. Perform [Pressure Relief Procedure, page 10](#).
2. Make sure all of the air pressure is relieved in the unit. If necessary, remove the air filter for access to the air regulator.
3. Remove the piston cover.

NOTE: There is a spring inside this cover.

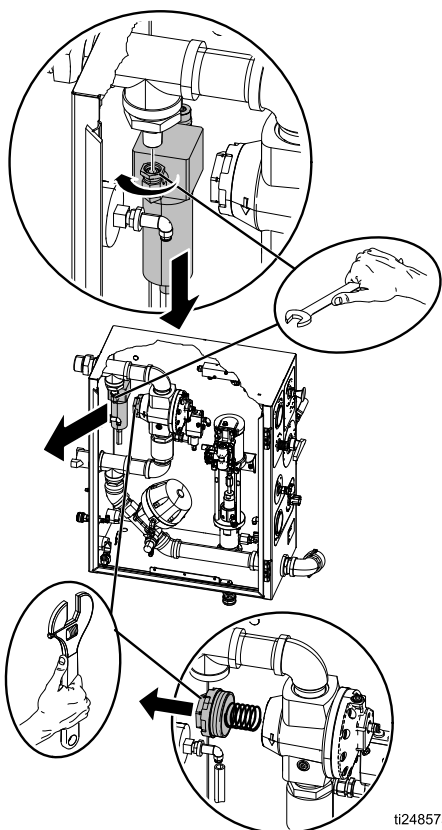

ti24857a

4. Remove the diaphragm cover for access to the diaphragm and to the end of the piston shaft.

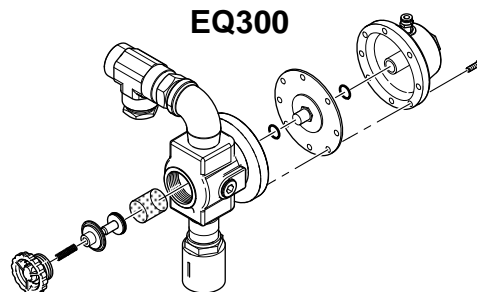

ti26088a

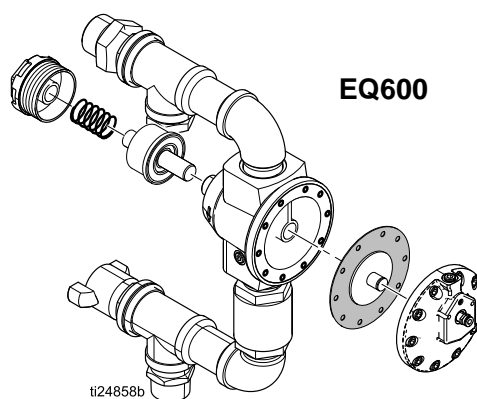

ti24858b

5. Remove the diaphragm and inspect for any cracks or tears. Replace the diaphragm if necessary.
6. Carefully remove the spring and piston assembly, then clean out any debris in the body of the regulator.

EQ300 Models only: Make sure wire mesh is free of debris.

7. Inspect the piston and its seal for any foreign matter that may have been the cause for the piston to stay open.
8. Inspect for any damage to the piston shaft where it interacts with the diaphragm cup. Replace components with excessive wear.

Flushing the Diaphragm Valve

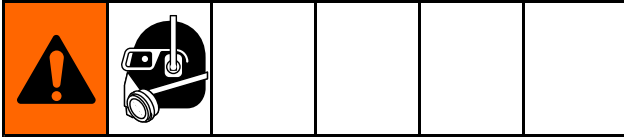

This procedure can be performed with the component still mounted in the panel.

If large-grit abrasive or other foreign matter becomes lodged in the diaphragm valve, it will become necessary to flush the valve. This is a simple procedure; however, it does cause the release of a large volume of air to escape through the released quick coupling. You need to be prepared for the release of air by pulling the quick coupler grommet out of its groove so that it does not get lost.

1. Operate the unit in WASH (see [Using the Wash Feature, page 19](#)) until all abrasive clears from the blast hose.



ti24142a

2. Close the abrasive ball valve, then turn the selector valve to RINSE. Blast until the hose is clear of all abrasive and water.

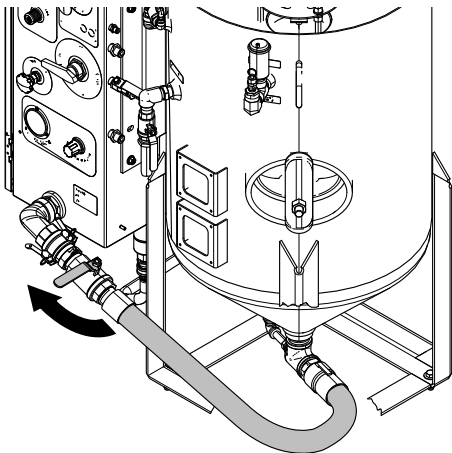

ti26067a

3. Disconnect the quick coupling at the abrasive ball valve (not at the bottom of the pot).

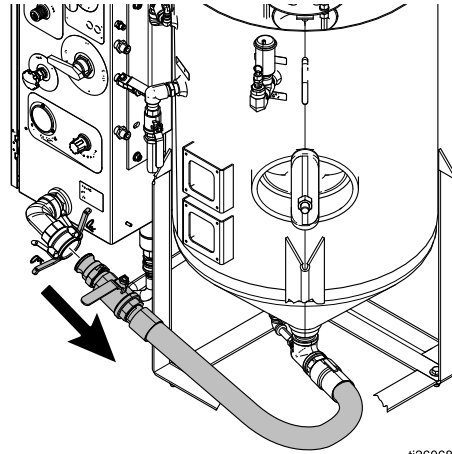

ti26068a

4. Turn the selector valve to WASH. Remain in WASH until all debris is clear. Remove the grommet in the quick coupler.
5. Make sure nothing is in the path of the open quick coupler, then engage the blast control switch briefly and several times.

NOTE: High flow air should escape through the cam-lock coupling. If this does not occur, the diaphragm valve is malfunctioning. Replace entire diaphragm canister.

NOTE: Do not disassemble the canister.

6. Hold the male end of the quick coupler up to the water coming from the cam-lock end of the coupler. Clean off any dirt or abrasive.
7. Turn the selector valve to RINSE to stop the flow of water.
8. Re-insert the grommet into its internal groove inside the cam-lock.
9. Reconnect the quick coupler. If properly cleaned and connected, there should be no leaks at the coupler during operation.

Repairing the Diaphragm Valve

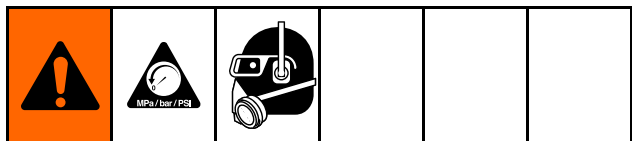

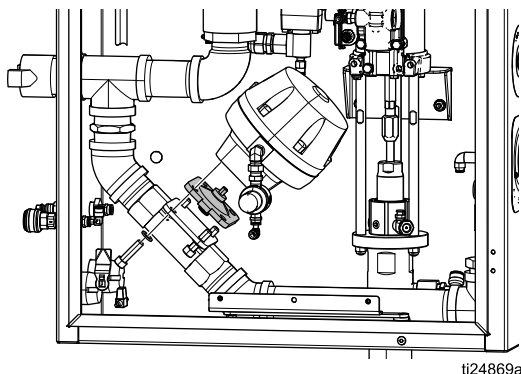

See [Enclosure Parts List, page 39](#) for repair kits.

NOTE: The diaphragm can be replaced without removing the assembly from the panel. You will need an 8 mm Allen wrench for the EQ600 and a 6 mm for the EQ300.

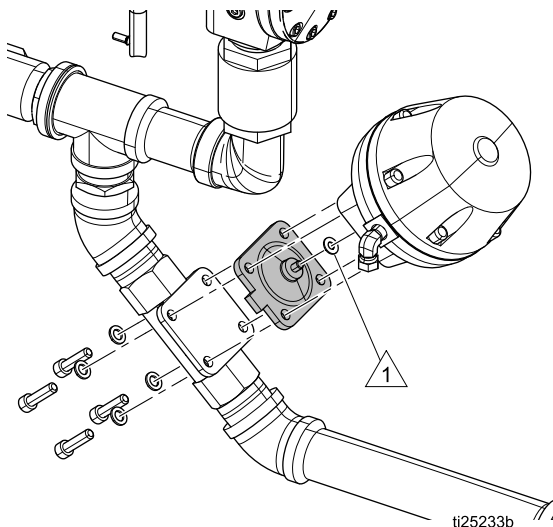

1. Perform the [Pressure Relief Procedure, page 10](#).
2. Apply more than 80 psi (5.5 Bar, MPa) air pressure to the regulator inlet to cause the piston to retract.
3. Loosen all 4 Allen-head cap-bolts evenly and then remove them completely while supporting the canister of the diaphragm valve.



 EQ300 shown, EQ600 has two shims.

NOTE: Do not disassemble the canister.

4. Replace the diaphragm (natural rubber compound) and hand-tighten it (only as far as necessary) to establish the alignment with the canister.

NOTE: There are one or two shims between the diaphragm and the actuator. Keep the shims and reuse them (they do not come with the replacement diaphragm). Do not cause any pre-load or torque on the diaphragm by over-tightening it in a misaligned position.

5. Insert all 4 Allen-head cap bolts and hand-tighten.
6. Tighten the cap-bolts in an alternating pattern (see image below) to 80 +/- 8 in-lb (9 +/- 0.9 N•m). This will cause a slight bulge in the diaphragm between the canister and the stainless steel casting.

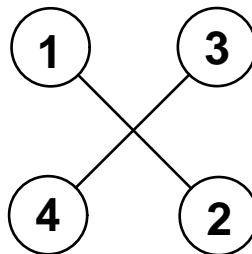

ti25234a

7. Relieve the pressure applied in step 2.
8. Test and confirm that the unit is working properly.

NOTE: This can be done using only water to charge the equipment – there is no need to use abrasive for this test.

Cleaning the Auto-Vent Valve

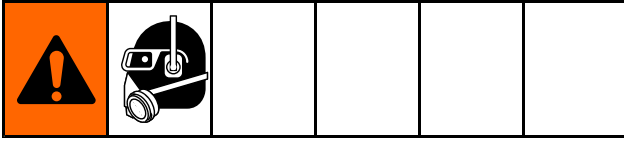

After the pop-up has been closed while filling the pot, the auto-vent valve should release air (you should be able to hear the air venting).

The pot pressure gauge will not show pressure until the auto-vent valve has bled all of the air and sealed. If the auto-vent valve does not release air, or if water leaks from the stem during the fill process, the stem valve may be clogged or faulty.

Perform the following procedure to clean a clogged auto-vent valve.

1. Try to push and quickly release the valve with your finger. If that does not cause the valve to seal, open the dump valve to release all of the pressure in the pot.
2. Open the dump valve to relieve pot pressure. Open the pop-up and drain the pot until the water level is below the pop-up.
3. Turn the selector valve to RINSE.

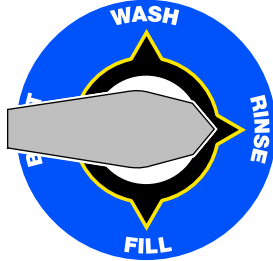

ti24143a

4. Use the rinse hose to force water backwards into the valve stem.

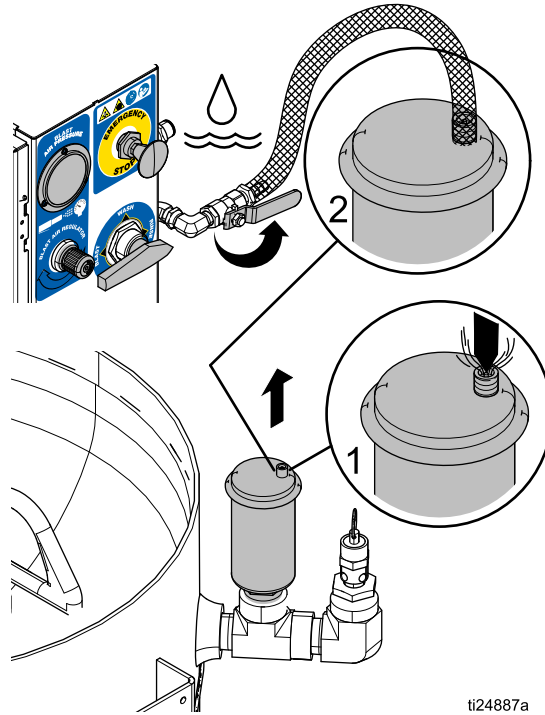



ti24887a

NOTE: If the previous steps fail to resolve the issue, replace the whole valve assembly.

NOTICE

The valve stem itself is internally attached to the float and it is not field-serviceable. Do not try to remove the valve stem. Damage to the equipment will occur.

Replacing the DataTrak Battery

					
FIRE AND EXPLOSION HAZARD					
To reduce the risk of fire and explosion, the battery must be replaced in a non-hazardous location.					
Use only an approved replacement battery (see table). Use of an unapproved battery will void Graco's warranty.					

Replace Battery

1. Unscrew cable from the back of the reed switch assembly.
2. Remove the cable from the two cable clips.

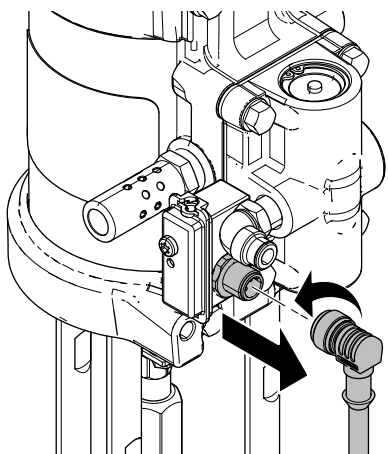

ti24946a

3. Remove the DataTrak module from the bracket. Take the module and attached cable to a non-hazardous location.

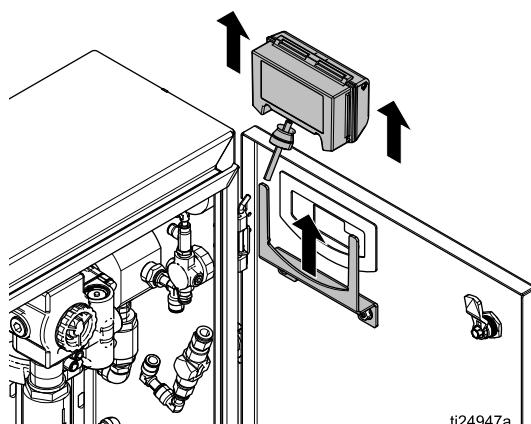

ti24947a

4. Remove the two screws on the back of the module to access the battery.
5. Disconnect the used battery and replace it with an approved battery.

Approved Batteries
Energizer alkaline #522
Varta alkaline #4922
Ultralife lithium #U9VL
Duracell alkaline #MN1604

Replacing the DataTrak Fuse

<p>FIRE AND EXPLOSION HAZARD</p> <p>To reduce the risk of fire and explosion, the fuse must be replaced in a non-hazardous location.</p> <p>Use only an approved replacement fuse (see table). Use of an unapproved fuse will void Graco's warranty.</p>					

Replace Fuse

1. Remove the screw, metal strap, and plastic holder.
2. Pull the fuse away from the board
3. Replace with an approved fuse.

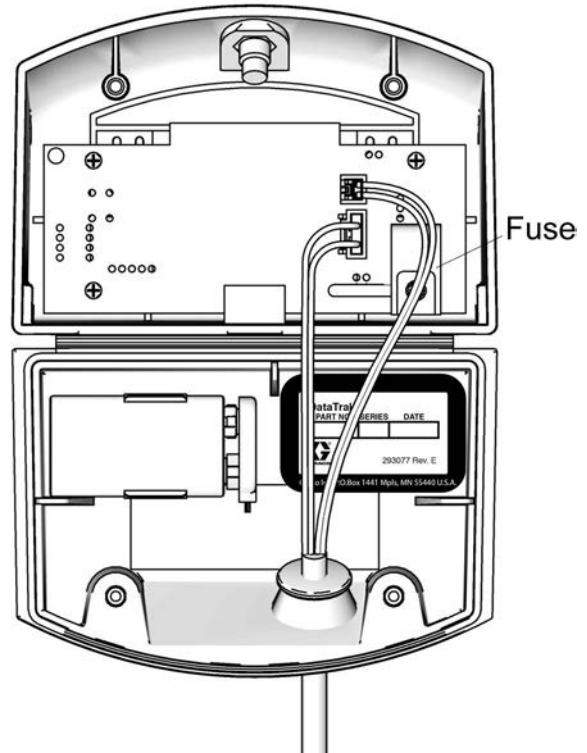

Approved Fuses		
DataTrak Part Number	*Series Letter	Fuse Required
289822	A or B	24C580
	C and later	24V216
All other part numbers	A	24C580
	B and later	24V216

Notes

Parts

EQ300C and EQ600C

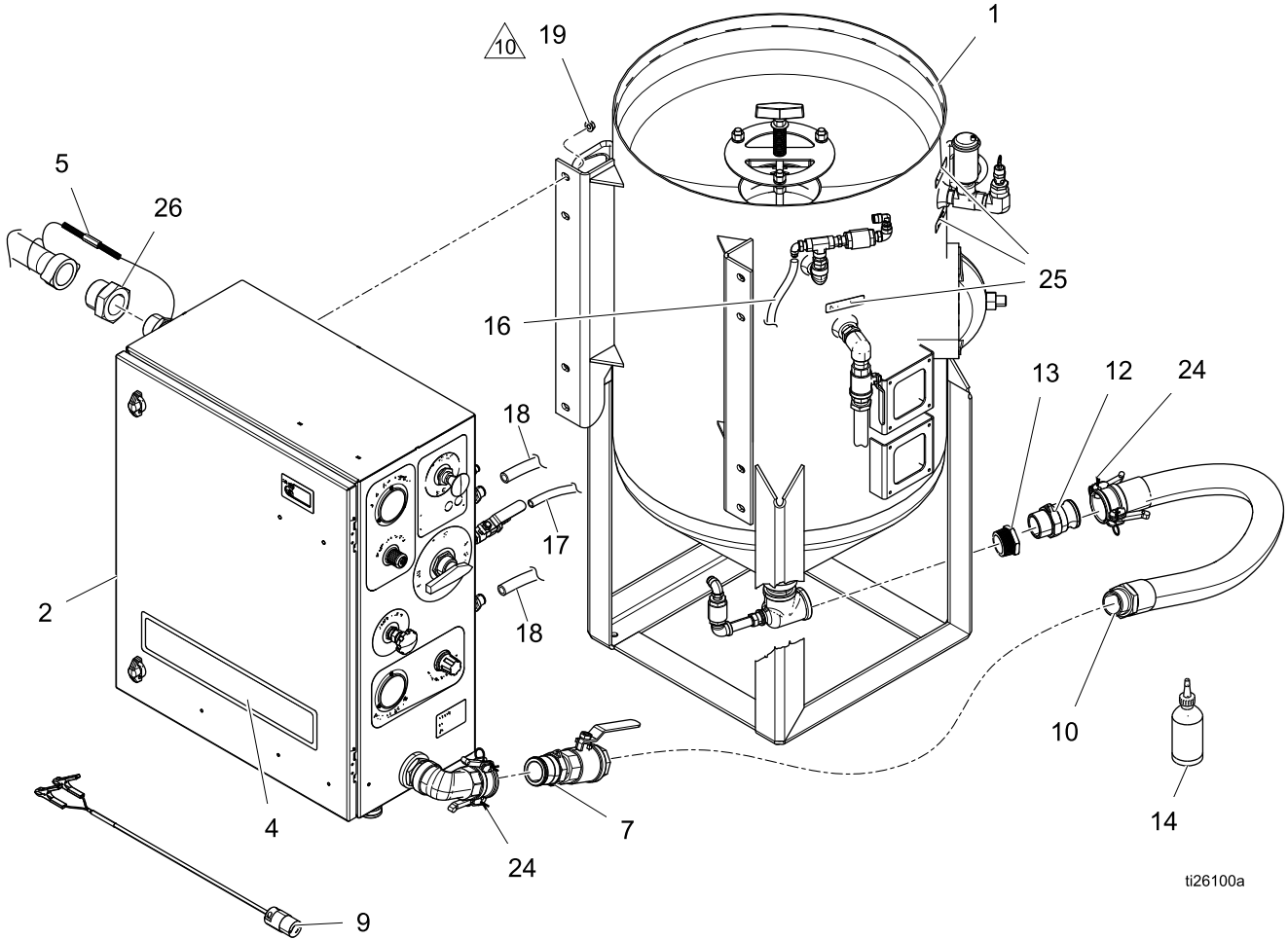

ti26100a

 *Apply anti-seize to studs. Torque to 25 – 30 ft-lb (33.8 – 40.6 N•m).*

EQ300C and EQ600C Parts List

Ref.	Part	Description	Qty.	Ref.	Part	Description	Qty.
1	---	PRESSURE POT, 6.5 cf, assy	1	16	EQ1881	HOSE, tubing, natural, 1/4 in.	2 ft
2	---	ENCLOSURE, blast	1	17	EQ1840	HOSE, braided, clear, 3/8 ID	5 ft
4	---	LABEL, branding	1	18	EQ1273	HOSE, tubing, natural, 3/8 in.	4 ft
5	17D786	KIT, replacement, hose restraint	1	19	128226	NUT, flange, 3/8-16, sst	4
7	EQ5135+	VALVE, abrasive, media, 1 1/2 in.	1	24	17D787	KIT, replacement, coupler pin	1
	EQ5149*	VALVE, abrasive, media, 1 1/4 in.		▲25	17F871	LABEL, warning	1
9	EQ5183	CABLE, battery, electric, blast control	1	26	EQ1866*	FITTING, ground boss, spud, 1-1/4 in.	1
10	EQ5208+	HOSE, abrasive media, 1 1/2 in.	1		EQ1829+	FITTING, ground boss, spud, 1-1/2 in.	1
	EQ1943*	HOSE, abrasive media, 1 1/4 in.					
12	EQ1046+	ADAPTER, cam groove, type F, ss	1				
	EQ1931*	ADAPTER, cam groove, type F, ss					
13	123002*	FITTING, bushing, sst, 1-1/2 x 1-1/4	1				
14	206994	FLUID, TSL, 8 oz. bottle	1				

* EQ300 Models

+ EQ600 Models

▲ Replacement Danger and Warning labels are available at no cost.

Enclosure

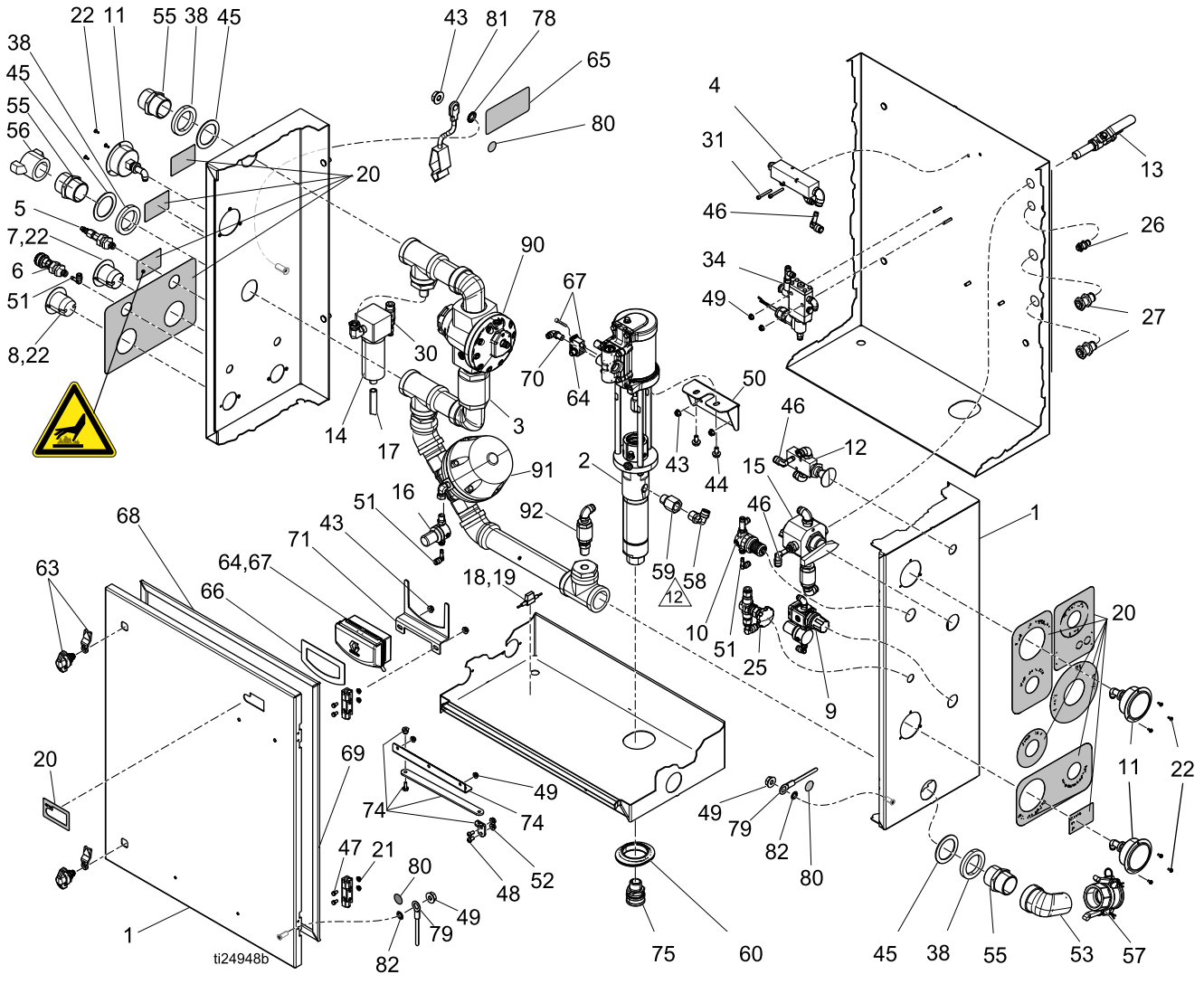

Torque fitting to 35 – 40 ft-lb (47 – 54 N•m).

Enclosure Parts List

Ref.	Part	Description	Qty.	Ref.	Part	Description	Qty.
1	-----	ENCLOSURE, ss, el, 30 in. x 24 in. x 12 in.	1	52	15U698	NUT, hex, flange, serrated	2
2	24V672	PUMP, water, sst, 3:1	1	53	-----	FITTING, elbow, street, 90 degree, npt, ss	1
3	-----	KIT, blast plumbing	1	55	-----	FITTING, nipple, hex, npt, ss	3
4	EQ5109	KIT, manifold	1	56	EQ1335*	COUPLER, sandblast, tank, brass, 1-1/4 in.	1
5	EQ5112	KIT, blast control, return	1		EQ1934+	COUPLER, sandblast, tank, brass, 1-1/2 in.	1
6	EQ5113	KIT, blast control, output	1	57	EQ1867*	COUPLER, cam, lock, type D, ss, 1-1/4 in.	1
7	EQ1790□	PLUG, twist-lock, flanged inlet	1		EQ1868+	COUPLER, cam, lock, type D, ss, 1-1/2 in.	1
	128142◆	PLUG, hole, snap-in, 1-3/4 in.	1	58	127846	FITTING, elbow, push-to-connect, 1/2 in.	1
8	EQ1791□	CONNECTOR, flanged inlet, twist-lock	1	59	-----	FITTING, adapter	1
	128142◆	PLUG, hole, snap-in, 1-3/4 in.	1	60	17B912	GROMMET, pump, mounting	1
9	17C132	REGULATOR, pump	1	63	17D685	KIT, replacement, door latch	2
10	17C625	REGULATOR, blast, 125 psi	1	64	122030	CABLE, GCA, M12-5P	1
11	17C133	KIT, gauge and fitting	3	▲ ₆₅	16P265◆	LABEL, warning	1
12	EQ5108	KIT, E-stop, 3/8 in. npt	1	66	-----	GASKET, EcoQuip, DataTrak	1
13	EQ5125	VALVE, rinse, 3/8 in. npt	1	67	24A592	KIT, DataTrak, smarts, cycle count only	1
14	EQ5110	KIT, air filter, 3/8 in. tube	1	68	-----	GASKET, EcoQuip, enclosure	2
15	EQ5181	VALVE, selector, 5-way	1	69	-----	GASKET, EcoQuip, enclosure	2
16	EQ5119	REGULATOR, fixed, 80 psi	1	70	121022	FITTING, elbow, male, 1/4 npt	1
17	EQ1840	HOSE, clear, braided, 3/8 in. ID	2 ft	71	-----	BRACKET, EcoQuip, DataTrak	1
18	EQ1527□	FITTING, holder, fuse, ATM type	1	74	17D686	DOOR, stay	1
19	EQ1844□	FUSE, ATM, blade type, 3 amp	1	75	EQ1846	COUPLER, interchange, straight	1
▲ ₂₀	17F871	LABEL, safety	1	78	100985◆	WASHER, lock ext	1
21	127918	NUT, flange, serrated, m5	4	79	194337◆	WIRE, grounding, door	1
22	127929□	SCREW, sems, #6-32, 3/8 in. sst	22	▲ ₈₀	186620◆	LABEL, ground symbol	3
	127929◆	SCREW, sems, #6-32, 3/8 in. sst	18	81	237686◆	WIRE, ground assembly with clamp	1
25	EQ5160	VALVE, needle, dose	1	82	555629◆	WASHER, #10, external tooth lock	2
26	125420	FITTING, bulkhead, M14 x 1/4 tube	1	90	-----	REGULATOR, air	1
27	EQ1115	BULKHEAD, connector, union 3/8 in.	2		*17C129	KIT, repair, major	
30	EQ1759	FITTING, stem, reducer, 1/4 in. x 3/8 in. tube	1		+17C131	KIT, repair, diaphragm	
31	127932	SCREW, sems, #10-32, 1.5 in. sst	2		+17F535	KIT, repair, piston	
34	EQ5179□	RELAY, air pilot, electric/pneumatic blast control	1		+17F536	KIT, repair, o-ring	
	EQ7199◆	RELAY, air pilot, pneumatic blast control	1	91	-----	VALVE, diaphragm	1
38	17H165*	KIT, spacer, bc, 200/300	1		*17C127	KIT, repair	
	17H166+	KIT, spacer, bc, 400/600	1		+17C128	KIT, repair	
43	127917	NUT, flange, serrated, 1/4-20 ss	5		*17F505	KIT, canister	
44	111799	SCREW, cap, hex, hd	2		+17F504	KIT, canister	
45	-----	SPACER, washer, shim, ss	AR	92	EQ5139	KIT, wash valve assembly	1
46	EQ1122	FITTING, elbow, stem, 3/8 in.	3				
47	111639	SCREW, cap, hex, hd	4				
48	128666	SCREW	2				
49	127908	NUT, flange, serrated, #10-32, ss	6				
50	-----	BRACKET, pump	1				
51	EQ1121	FITTING, elbow, stem, 1/4 in.	3				

□ For non-ATEX approved systems

◆ For ATEX approved systems

* EQ300 Models

+ EQ600 Models

▲ Replacement Danger and Warning labels are available at no cost.

Pressure Pot

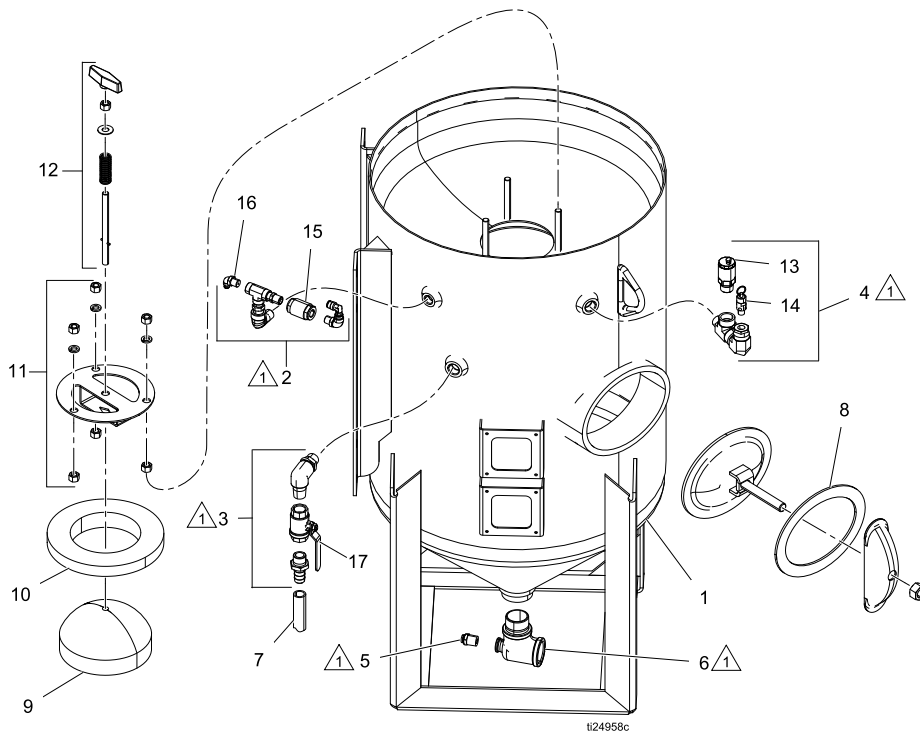

Pressure Pot Parts List

Ref.	Part	Description	Qty.	Ref.	Part	Description	Qty.
1	25A057	PRESSURE POT, blast, 6.5 cubic ft.	1	11#	24X768	KIT, replacement, alignment bracket	1
2	24X765	KIT, pressure pot, check valve	1	12#	24X770	KIT, replacement, pop-up T-handle	1
3	24X766	KIT, pressure pot, dump valve	1	13*	EQ1860	VALVE, auto-vent, 3/4 npt	1
4	24X767	KIT, pressure pot, auto-vent	1	14*	127699	VALVE, safety, 150 psi	1
5	16G247	FITTING, 1/2 npt x 3/8 tube	1	15†	EQ1034	VALVE, check, 3/8 in. sst	1
6	EQ5148	KIT, pressure pot, unequal tee	1	16†	127852	FITTING, elbow, swivel, push-to-connect	1
7	EQ1360	HOSE, clear, braided, 3/4 in. ID	3 ft	17‡	EQ1003	VALVE, ball, 3/4 not, sst	1
8#	17D790	KIT, replacement, handway gasket	1	# Included in assembly 1			
9#	24X764	KIT, replacement, pop-up head, 6 in.	1	† Included in assembly 2			
10#	17F065	KIT, replacement, pop-up gasket, 6 in. skirt	1	‡ Included in assembly 3			
				* Included in assembly 4			
				△ 1 Apply sealant to pipe threads.			

Blast Hoses

EQ5234

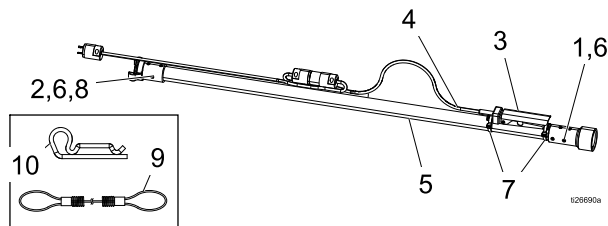

EQ5235

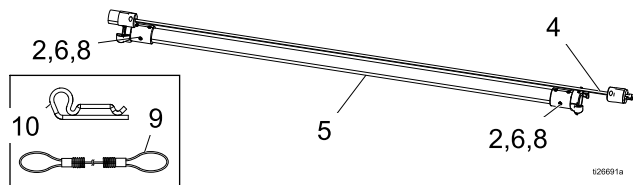

EQ5236

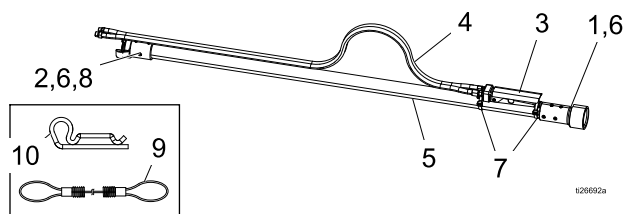

EQ5237

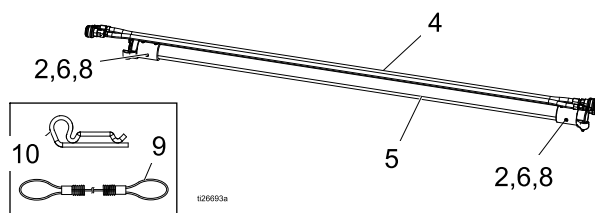

Ref.	Part	Description	Qty.
1	EQ1843*	HOLDER, nozzle, nylon	1
	128616	HOLDER, nozzle, brass	1
2	EQ1842*	COUPLER, blast hose, nylon	1
	128617	COUPLER, blast hose, brass	1
3	17D791	HANDLE, blast, control switch, electric	1
	17D788	HANDLE, blast, control switch, pneumatic	1
4	-----	(see Blast Control Hoses/Cables, page 46)	
5	-----	(see Blast Hoses with Control Hose/Cables, page 45)	
6	17H239	KIT, screws, fh, sst, 8 pk	1
7	17H240	KIT, cable ties, 6 pk	1
8	17C459*	GASKET, nylon blast coupler	1
	17C124	GASKET, brass blast coupler	1
9	17D786	KIT, replacement, whipcheck	1
10	17D787	KIT, replacement, hairpin, hose	1

* Non-ATEX systems only

Hose Schematic

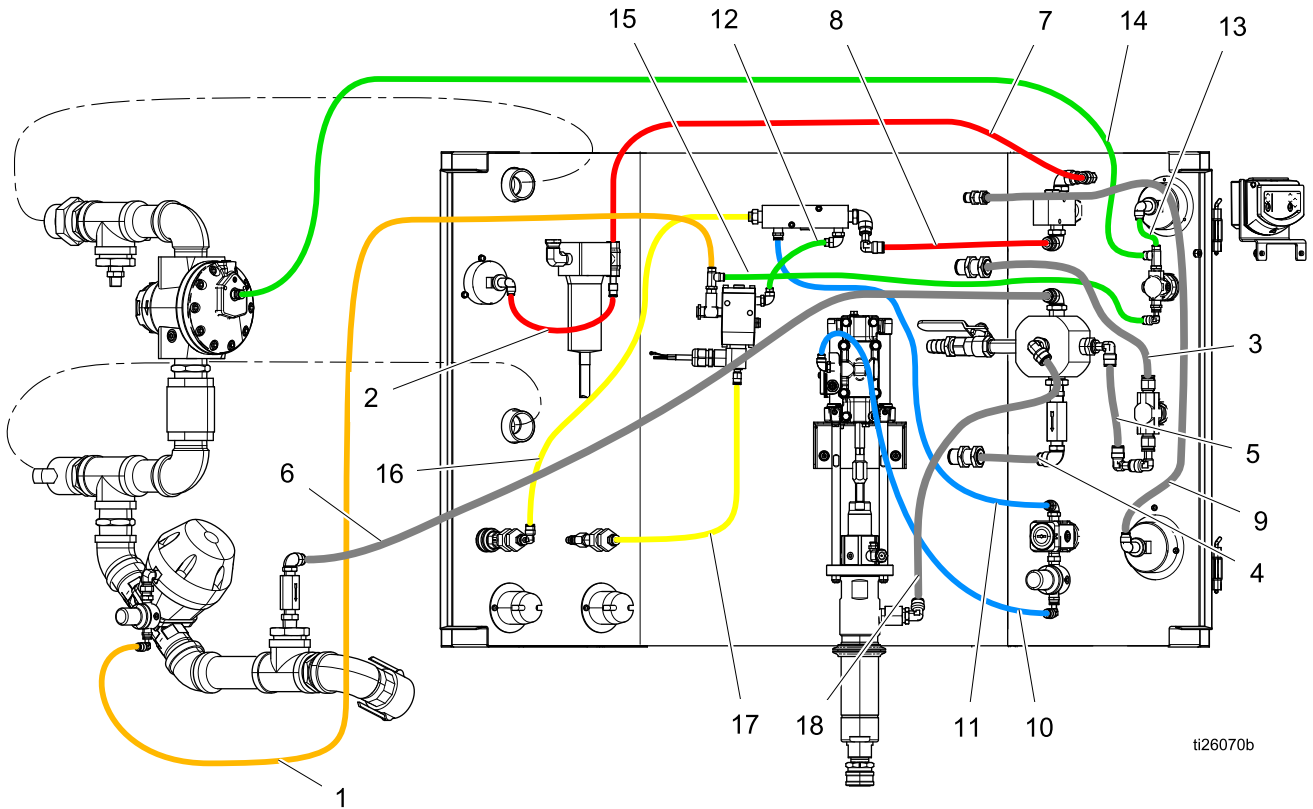

ti26070b

Ref.	Part	Color, Tube Size	Cut Length	Ref.	Part	Color, Tube Size	Cut Length
1	EQ1296	Orange, 1/4 in. OD	42.0 in.	10	EQ1883	Blue, 1/4 in. OD	32.0 in.
2	EQ1882	Red, 1/4 in. OD	16.0 in.	11	EQ1883	Blue, 1/4 in. OD	20.75 in.
3	EQ1273	Natural, 3/8 in. OD	12.25 in.	12	EQ1884	Green, 1/4 in. OD	7.38 in.
4	EQ1273	Natural, 3/8 in. OD	2.88 in.	13	EQ1884	Green, 1/4 in. OD	10.5 in.
5	EQ1273	Natural, 3/8 in. OD	5.5 in.	14	EQ1884	Green, 1/4 in. OD	11.25 in.
6	EQ1273	Natural, 3/8 in. OD	21.0 in.	15	EQ1884	Green, 1/4 in. OD	19.88 in.
7	EQ1297	Red, 3/8 in. OD	24.5 in.	16	EQ1885	Yellow, 1/4 in. OD	34.5 in.
8	EQ1297	Red, 3/8 in. OD	5.25 in.	17	EQ1885	Yellow, 1/4 in. OD	17.0 in.
9	EQ1881	Natural 1/4 in. OD	21.75 in.	18	EQ1275	Natural, 1/2 in. OD	19.63 in.

Vapor Abrasive Blast Systems and Accessories

EcoQuip System Configurator

Model	Series	Trailer Option	Package (blast hose and nozzle)	Configuration
EQ	3	0	X	S
EQ	1 = 100	0 = Non-Trailer (100, 300, 600 Series)	0 = Bare package (no blast hose or nozzle)	3 = Tier 3 compliant compressor (400 Series)
	2 = 200	E = Electric brakes (200, 400 Series)	E = Complete package, electric blast control, includes 15 m (50 ft) blast hose and nozzle	4 = Tier compliant compressor (200, 400 Series)
	3 = 300	H = Hydraulic brakes (200 Series)	P = Complete package, pneumatic blast control, includes 15 m (50 ft) blast hose and nozzle	C = No crash frame or water tank (300, 600 Series)
	4 = 400		X = Complete package, ATEX approved, includes 15 m (50 ft) blast hose and nozzle (100, 300, 600 Series)	M = Mobile unit (100 Series)
	6 = 600			S = Skid unit (300, 600 Series)

Accessory: Air Inlet Ball Valve/Strainer Kit

24X419 – 1.25 in. kit (100, 300 series)

24X420 – 1.50 in. kit (600 series)

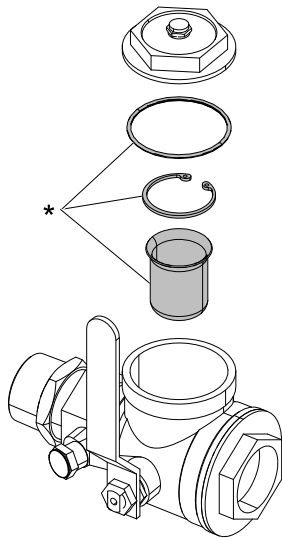

t26269a

* Included in repair kit 17G019.

Model Series

Part	Description
100 Series	
EQ100M	Bare package, mobile unit
EQ10EM	Complete package, electric blast control, mobile unit
EQ10PM	Complete package, pneumatic blast control, mobile unit
EQ10XM	Complete package, pneumatic blast control, ATEX approved, mobile unit
300 Series	
EQ300S	Bare package, skid/crash frame and water tank
EQ300C	Bare package, no skid/crash frame or water tank
EQ30ES	Complete package, electric blast control, skid/crash frame and water tank
EQ30EC	Complete package, electric blast control, no skid/crash frame or water tank
EQ30PS	Complete package, pneumatic blast control, skid/crash frame and water tank
EQ30PC	Complete package, pneumatic blast control, no skid/crash frame and water tank
EQ30XS	Complete package, pneumatic blast control, ATEX approved, skid/crash frame and water tank
EQ30XC	Complete package, pneumatic blast control, ATEX approved, no skid/crash frame and water tank
600 Series	
EQ600S	Bare package, skid/crash frame and water tank
EQ600C	Bare package, no skid/crash frame or water tank
EQ60ES	Complete package, electric blast control, skid/crash frame and water tank
EQ60EC	Complete package, electric blast control, no skid/crash frame or water tank
EQ60PS	Complete package, pneumatic blast control, skid/crash frame and water tank
EQ60PC	Complete package, pneumatic blast control, no skid/crash frame and water tank
EQ60XS	Complete package, pneumatic blast control, ATEX approved, skid/crash frame and water tank
EQ60XC	Complete package, pneumatic blast control, ATEX approved, no skid/crash frame and water tank
200 Series Trailers	
EQ2E04	Bare package, electric brakes, Tier 4i
EQ2EE4	Complete package, electric blast control, electric brakes, Tier 4i
EQ2EP4	Complete package, pneumatic blast control, electric brakes, Tier 4i
EQ2H04	Bare package, hydraulic brakes, Tier 4i
EQ2HE4	Complete package, electric blast control, hydraulic brakes, Tier 4i
EQ2HP4	Complete package, pneumatic blast control, hydraulic brakes, Tier 4i
400 Series Trailers	
EQ4E03	Bare package, electric brakes, Tier 3
EQ4EE3	Complete package, electric blast control, electric brakes, Tier 3
EQ4EP3	Complete package, pneumatic blast control, electric brakes, Tier 3
EQ4E04	Bare package, electric brakes, Tier 4i
EQ4EE4	Complete package, electric blast control, electric brakes, Tier 4i
EQ4EP4	Complete package, pneumatic blast control, electric brakes, Tier 4i

100, 200, 300 Series complete packages include 1.0 in. ID 4-ply hose and #7 standard nozzle.
 400, 600 Series complete packages include 1.25 in. ID 2-ply hose and #8 performance nozzle.

Blast Hoses with Control Hose/Cables

Part	ID	Blast Control	Coupler 1	Coupler 2	Length	Models	ATEX Approved
EQ5237	1.0 in.	Pneumatic	2-Prong coupler, nylon	2-Prong coupler, nylon	15 m (50 ft)	EQ100M, EQ200T, EQ300C, EQ300S	No
EQ5235	1.0 in.	Electric	2-Prong coupler, nylon	2-Prong coupler, nylon	15 m (50 ft)		No
EQ5236	1.0 in.	Pneumatic	Nozzle holder, nylon	2-Prong coupler, nylon	15 m (50 ft)		No
EQ5234	1.0 in.	Electric	Nozzle holder, nylon	2-Prong coupler, nylon	15 m (50 ft)		No
24X673	1.0 in.	Pneumatic	Nozzle holder, brass	2-Prong coupler, brass	15 m (50 ft)	EQ10XM, EQ30XC, EQ30XS	Yes
24X676	1.0 in.	Pneumatic	2-Prong coupler, brass	2-Prong coupler, brass	15 m (50 ft)		Yes
EQ5077	1.25 in.	Pneumatic	2-Prong coupler, nylon	2-Prong coupler, nylon	30 m (100 ft)	EQ400T, EQ600C, EQ600S	No
EQ5084	1.25 in.	Electric	2-Prong coupler, nylon	2-Prong coupler, nylon	30 m (100 ft)		No
EQ5082	1.25 in.	Electric	2-Prong coupler, nylon	2-Prong coupler, nylon	15 m (50 ft)		No
EQ5073	1.25 in.	Pneumatic	2-Prong coupler, nylon	2-Prong coupler, nylon	15 m (50 ft)		No
EQ5071	1.25 in.	Pneumatic	Nozzle holder, nylon	2-Prong coupler, nylon	15 m (50 ft)		No
EQ5080	1.25 in.	Electric	Nozzle holder, nylon	2-Prong coupler, nylon	15 m (50 ft)		No
24X672	1.25 in.	Pneumatic	Nozzle holder, brass	2-Prong coupler, brass	15 m (50 ft)	EQ60XC, EQ60XS	Yes
24X674	1.25 in.	Pneumatic	2-Prong coupler, brass	2-Prong coupler, brass	15 m (50 ft)		Yes
24X675	1.25 in.	Pneumatic	2-Prong coupler, brass	2-Prong coupler, brass	30 m (100 ft)		Yes

100, 200, 300 Series complete packages include 1.0 in. ID 4-ply hose and #7 standard nozzle.
400, 600 Series complete packages include 1.25 in. ID 2-ply hose and #8 performance nozzle.

Blast Hoses without Control Hose/Cables

Part	ID	Blast Control	Coupler 1	Coupler 2	Length	Models	ATEX Approved
17F496	1.0 in.	None	Nozzle holder, nylon	2-Prong coupler, nylon	15 m (50 ft)	EQ100M, EQ200T, EQ300C, EQ300S	No
17F498	1.0 in.	None	2-Prong coupler, nylon	2-Prong coupler, nylon	15 m (50 ft)		No
24X727	1.0 in.	None	Nozzle holder, brass	2-Prong coupler, brass	15 m (50 ft)	EQ10XM, EQ30XC, EQ30XS	Yes
24X729	1.0 in.	None	2-Prong coupler, brass	2-Prong coupler, brass	15 m (50 ft)		Yes
17F497	1.25 in.	None	Nozzle holder, nylon	2-Prong coupler, nylon	15 m (50 ft)	EQ400T, EQ600C, EQ600S	No
17F499	1.25 in.	None	2-Prong coupler, nylon	2-Prong coupler, nylon	15 m (50 ft)		No
17F500	1.25 in.	None	2-Prong coupler, nylon	2-Prong coupler, nylon	30 m (100 ft)		No
24X728	1.25 in.	None	Nozzle holder, brass	2-Prong coupler, brass	15 m (50 ft)	EQ60XC, EQ60XS	Yes
24X730	1.25 in.	None	2-Prong coupler, brass	2-Prong coupler, brass	15 m (50 ft)		Yes
24X731	1.25 in.	None	2-Prong coupler, brass	2-Prong coupler, brass	30 m (100 ft)		Yes

100, 200, 300 Series complete packages include 1.0 in. ID 4-ply hose and #7 standard nozzle.
400, 600 Series complete packages include 1.25 in. ID 2-ply hose and #8 performance nozzle.

Blast Control Hoses/Cables

Part	Description
17F501	Blast control hose, pneumatic twinline, 55 ft
24X746	Blast control hose, pneumatic twinline, 55 ft, ATEX approved
17F502	Blast control hose, pneumatic twinline, 55 ft, extension
24X744	Blast control hose, pneumatic twinline, 55 ft. extension, ATEX approved
17F503	Blast control hose, pneumatic twinline, 110 ft, extension
24X745	Blast control hose, pneumatic twinline, 110 ft, extension, ATEX approved
17F506	Blast control cable, electric, 55 ft
17F507	Blast control cable, electric, 105 ft

Nozzles

Part	Description	Inlet Size	Length	Thread Size	Sleeve Material	Insert Material
EQ1710	Standard #7 (100, 200, 300 Series)	1.25 in.	7.95 in.	50mm Contractor (2 in. 4-1/2 UNC-2A)	Polyurethane	BP200 Sialon
EQ1711	Standard #8 (400, 600 Series)	1.25 in.	9.0 in.			
EQ7073*	High performance #7 (100, 300 Series)	1.25 in.	12.0 in.		Aluminum	BP200 Sialon
EQ7074*	High performance #8 (400, 600 Series)	1.25 in.	13.75 in.		Aluminum	Boron Carbide
EQ5166	Nozzle extension, 24 in.	1.25 in.	24.0 in.		Aluminum	NA

*Performance nozzles require 100 psi (7 bar, 0.7 MPa) or more air pressure at nozzle.

Other Accessories

Part	Description
17C126	Pump Retrofit Kit
24A592	DataTrak Module and Reed Switch
24X419	Air inlet ball valve strainer kit (100, 300 Series)
24X420	Air inlet ball valve strainer kit (600 Series)
17G019	Air inlet ball valve strainer repair kit

Common Spare Parts

Part	Description
17B186	Pump repair kit
17C459	Blast hose coupler gasket, nylon couplers
17C124	Blast hose coupler gasket, brass couplers
17C125	Gasket, abrasive ball valve cam-lock — 1.25 in. ID (100, 200, 300 Series)
17C453	Gasket, abrasive ball valve cam-lock — 1.5 in. ID (400, 600, Series)
17C127	Diaphragm valve repair kit (100, 200, 300 Series)
17C128	Diaphragm valve repair kit (400, 600 Series)
17F504	Diaphragm valve replacement canister (400, 600 Series)
17F505	Diaphragm valve replacement canister (100, 200, 300 Series)
17C129	Regulator major repair kit (100, 200, 300 Series)
17C131	Regulator diaphragm repair kit (400, 600 Series)
17F535	Regulator piston repair kit (400, 600 Series)
17F536	Regulator o-ring repair kit (400, 600 Series)
17D790	Handway gasket
17D789	Auto-vent valve
17D785	Pressure relief valve
17D786	Hose restraint
17D787	Coupler pin kit (6 pack)
206994	Throat Liquid Seal
17F065	Pop-up gasket
EQ1051	Nozzle gasket
EQ5183	Battery cable (100, 300, 600 Series)
17D788	Replacement handle, pneumatic blast control
17D791	Replacement handle, electric blast control (not for ATEX approved units)
EQ1818	Filter element, replacement
EQ1830	Filter float, replacement
EQ1842*	Blast hose coupler, nylon
EQ1843*	Nozzle holder, nylon

* Reuse stainless steel screws from blast hose assembly when replacing.

Dimensions

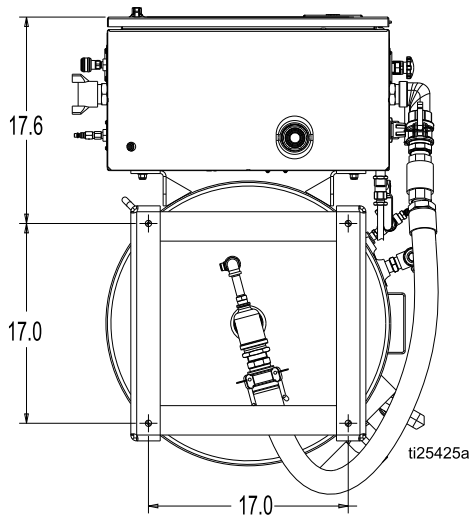
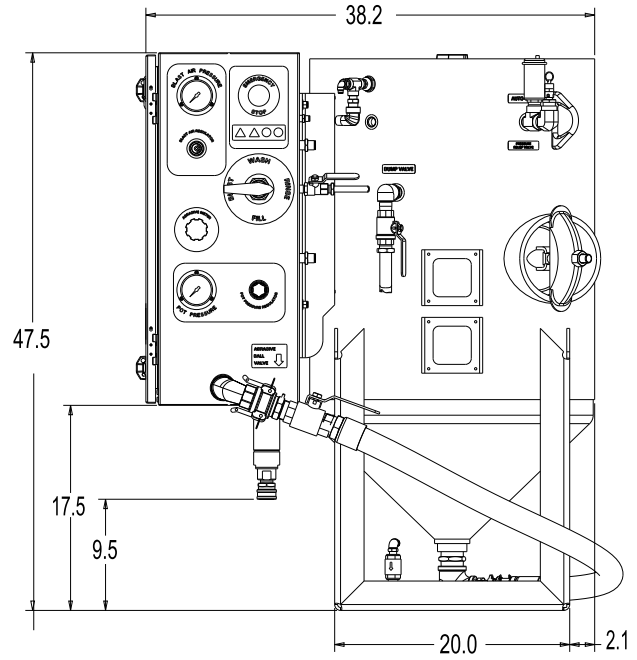
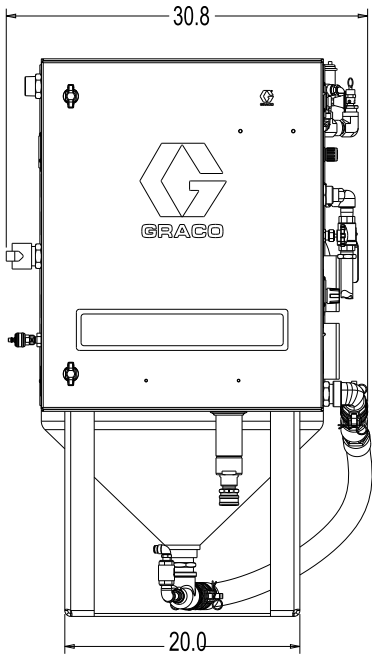

Technical Specifications

EQ300C	U.S.	Metric
Maximum Working Pressure	125 psi	8.6 bar, 0.86 MPa
Operating Temperature	35° – 110° F	1.6° – 43.3° C
Recommended Compressor Size	185 – 375 cfm	5.23 – 10.62 m ³ /min
Blast Hose Size	1 in. ID	25.4 mm ID
Abrasive Capacity	400 – 500 lb	181 – 227 kg
Dry Weight	450 lb	204 kg
Wet Weight	1600 lb	726 kg
Pressure Pot Volume	6.5 cubic feet	184 liters
<i>Air Supply Hose Minimum ID</i>		
185–600 cfm compressor and less than 100 ft hose length	1.5 in. ID	38 mm ID
Over 600 cfm compressor or greater than 100 ft. hose length	2 in. ID	51 mm ID
<i>Sound Data*</i>		
Sound Pressure Level	133 dB(A)	133 dB(A)
Sound Power Level	139 dB(A)	139 dB(A)
Instantaneous Sound Pressure Level	131 dB(C)	131 dB(C)
<i>*All readings were taken at the maximum system blast pressure 125 psi (8.6 bar, 0.86 MPa) from the operator position. The abrasive used was garnet and the substrate was steel. Tested in accordance with ISO 9614-2.</i>		

EQ600C	U.S.	Metric
Maximum Working Pressure	125 psi	8.6 bar, 0.86 MPa
Operating Temperature	35° – 110° F	1.6° – 43.3° C
Recommended Compressor Size	375 – 600 cfm	10.62–17.0 m ³ /min
Blast Hose Size	1.25 in. ID	31.75 mm ID
Abrasive Capacity	400 – 500 lb	181 – 227 kg
Dry Weight	450 lb	204 kg
Wet Weight	1600 lb	726 kg
Pressure Pot Volume	6.5 cubic feet	184 liters
<i>Air Supply Hose Minimum ID</i>		
185–600 cfm compressor and less than 100 ft hose length	1.5 in. ID	38 mm ID
Over 600 cfm compressor or greater than 100 ft. hose length	2 in. ID	51 mm ID
<i>Sound Data*</i>		
Sound Pressure Level	133 dB(A)	133 dB(A)
Sound Power Level	139 dB(A)	139 dB(A)
Instantaneous Sound Pressure Level	131 dB(C)	131 dB(C)
<i>*All readings were taken at the maximum system blast pressure 125 psi (8.6 bar, 0.86 MPa) from the operator position. The abrasive used was garnet and the substrate was steel. Tested in accordance with ISO 9614-2.</i>		

Graco Extended Warranty for EcoQuip™ Components

Graco warrants all equipment referenced in this document which is manufactured by Graco and bearing the Graco or EcoQuip name to be free from defects in material and workmanship on the date of sale to the original purchaser for use. Graco will, for three (3) years from the date of sale, repair or replace any part of the equipment determined by Graco to be defective. This warranty applies only when the equipment is installed, operated and maintained in accordance with Graco's written recommendations.

This warranty does not cover, and Graco shall not be liable for general wear and tear, or any malfunction, damage or wear caused by faulty installation, misapplication, abrasion, corrosion, inadequate or improper maintenance, negligence, accident, tampering, or substitution of non-Graco component parts. Nor shall Graco be liable for malfunction, damage or wear caused by the incompatibility of Graco equipment with structures, accessories, equipment or materials not supplied by Graco, or the improper design, manufacture, installation, operation or maintenance of structures, accessories, equipment or materials not supplied by Graco.

This warranty is conditioned upon the prepaid return of the equipment claimed to be defective to an authorized Graco distributor for verification of the claimed defect. If the claimed defect is verified, Graco will repair or replace free of charge any defective parts. The equipment will be returned to the original purchaser transportation prepaid. If inspection of the equipment does not disclose any defect in material or workmanship, repairs will be made at a reasonable charge, which charges may include the costs of parts, labor, and transportation.

THIS WARRANTY IS EXCLUSIVE, AND IS IN LIEU OF ANY OTHER WARRANTIES, EXPRESS OR IMPLIED, INCLUDING BUT NOT LIMITED TO WARRANTY OF MERCHANTABILITY OR WARRANTY OF FITNESS FOR A PARTICULAR PURPOSE.

Graco's sole obligation and buyer's sole remedy for any breach of warranty shall be as set forth above. The buyer agrees that no other remedy (including, but not limited to, incidental or consequential damages for lost profits, lost sales, injury to person or property, or any other incidental or consequential loss) shall be available. Any action for breach of warranty hereunder must be brought within the latter of two (2) years of the date of sale, or one (1) year after the warranty period expires.

GRACO MAKES NO WARRANTY, AND DISCLAIMS ALL IMPLIED WARRANTIES OF MERCHANTABILITY AND FITNESS FOR A PARTICULAR PURPOSE, IN CONNECTION WITH ACCESSORIES, EQUIPMENT, MATERIALS OR COMPONENTS SOLD BUT NOT MANUFACTURED BY GRACO. These items sold, but not manufactured by Graco (such as electric motors, switches, compressors, engines, trailer components, blast hose or other hose and blast nozzles), are subject to the warranty, if any, of their manufacturer. Graco will provide purchaser with reasonable assistance in making any claim for breach of these warranties.

In no event will Graco be liable for indirect, incidental, special or consequential damages resulting from Graco supplying equipment hereunder, or the furnishing, performance, or use of any products or other goods sold hereto, whether due to a breach of contract, breach of warranty, the negligence of Graco, or otherwise.

FOR GRACO CANADA CUSTOMERS

The Parties acknowledge that they have required that the present document, as well as all documents, notices and legal proceedings entered into, given or instituted pursuant hereto or relating directly or indirectly hereto, be drawn up in English. Les parties reconnaissent avoir convenu que la rédaction du présente document sera en Anglais, ainsi que tous documents, avis et procédures judiciaires exécutés, donnés ou intentés, à la suite de ou en rapport, directement ou indirectement, avec les procédures concernées.

Graco Information

For the latest information about Graco products, visit www.graco.com.

For patent information, see www.graco.com/patents.

To place an order, contact your Graco Distributor or call to identify the nearest distributor.

Phone: 612-623-6921 **or Toll Free:** 1-800-328-0211 **Fax:** 612-378-3505

All written and visual data contained in this document reflects the latest product information available at the time of publication.

Graco reserves the right to make changes at any time without notice.

Original Instructions. This manual contains English. MM 334667

Graco Headquarters: Minneapolis

International Offices: Belgium, China, Japan, Korea

GRACO INC. AND SUBSIDIARIES • P.O. BOX 1441 • MINNEAPOLIS MN 55440-1441 • USA

Copyright 2014, Graco Inc. All Graco manufacturing locations are registered to ISO 9001.

www.graco.com

Revision F, May 2016