

Center Rebuild Kit

406806B

Husky® 1050 Diaphragm Pumps

ENG

Kits 24B621 and 24D730



Important Safety Instructions

Read all warnings and instructions in the Husky® 1050 Air-Operated Diaphragm Pump Repair/Parts manual. Save all instructions.

Ref.	Description	Qty.
101	VALVE, pilot	2
102	CARTRIDGE, pilot	2
103	O-RING, cartridge	2
104	SHAFT, center	1
105	BEARING, center shaft	2
106	U-CUP, center shaft	2
107	GASKET, air valve	1
108	SCREW, M6 x 25 (for use with aluminum housings)	4
109	NUT (Kit 24B621, for use with plastic housings)	4
110	O-RING, manifold, PTFE (not shown)	8

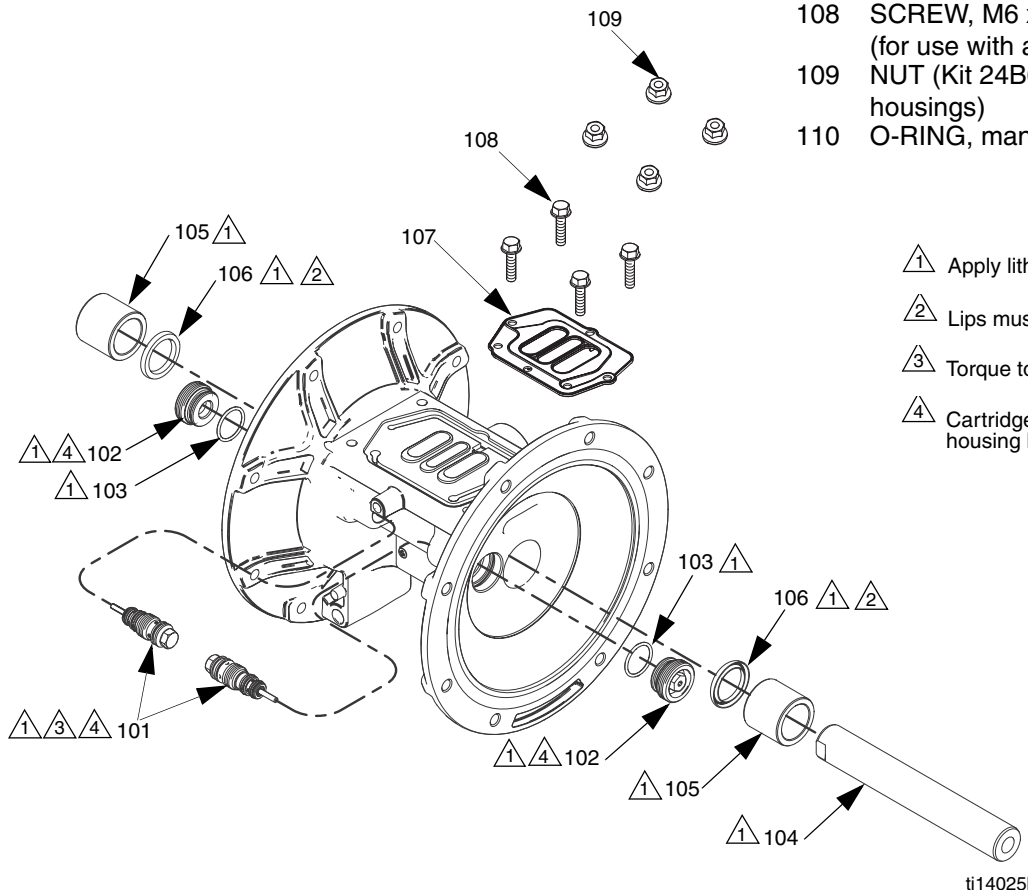

- ⚠️ 1 Apply lithium-based grease.
- ⚠️ 2 Lips must face out of housing.
- ⚠️ 3 Torque to 20-25 in.-lb (2.3-2.8 N•m).
- ⚠️ 4 Cartridges (102) must be installed in housing before pilot valves (101).

Graco Inc. P.O. Box 1441 Minneapolis, MN 55440-1441
 406806 Rev. B 11/2009
 Copyright 2009, Graco Inc. is registered to ISO 9001

See reverse for assembly instructions.

Assembly

NOTE: Apply lithium-based grease whenever instructed to grease.

1. Clean all parts and inspect for wear or damage. Replace parts as needed.
2. If removed, grease and install the new pilot valve cartridges (102) and o-rings (103). Screw in until seated.

NOTE: Cartridges (102) *must* be installed before pilot valves (101).

3. Grease and install the pilot valves (101). Torque to 20-25 in.-lb (2.3-2.8 N•m). Do not over-torque.
4. Grease and install the diaphragm shaft u-cup packings (106) so the lips face **out** of the housing.
5. If removed, insert the new bearings (105) into the center housing. Use a press or a block and rubber mallet to press-fit the bearing so it is flush with the surface of the center housing.
6. Assemble and install the shaft (104), one of the diaphragm assemblies, and the first fluid cover. See **Reassembly** in the manual or follow directions on the sheet that accompanies all diaphragm kits.
7. To ensure proper seating and extend diaphragm life, attach the second fluid cover with air pressure on the pump.
 - a. Place the tool (supplied with diaphragms) where the air valve gasket (107) normally goes. Arrows (A) must face toward the fluid cover that is already attached.

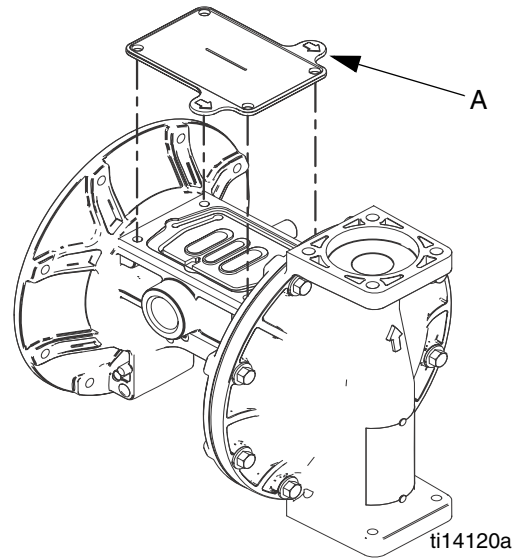

FIG. 1. Fluid cover tool

- b. Reattach the air valve.
 - c. Supply a minimum of 20 psi (0.14 MPa, 1.4 bar) air pressure to the air valve. Shop air may be used. The diaphragm will shift so the second fluid cover will seat properly. Keep air pressure on until the second fluid cover is attached.
 - d. Attach the second fluid cover (3). See **Torque Instructions** in the manual.
 - e. Remove the air valve and the tool.
8. Align the new air valve gasket (107) on the center housing, then attach the air valve. See **Torque Instructions** in the manual.
 9. Reassemble the ball check valves and manifolds as explained in the manual.