

HFRL and HFRS

3A2176K

EN

**Hydraulic, Plural-Component, Fixed-Ratio Proportioner.
For pouring and dispensing laminates and silicones.**

For professional use only. Not approved for use in explosive atmospheres or hazardous locations.



Important Safety Instructions

Read all warnings and instructions in this manual. Save these instructions.

See page 4 for model information and maximum working pressure.

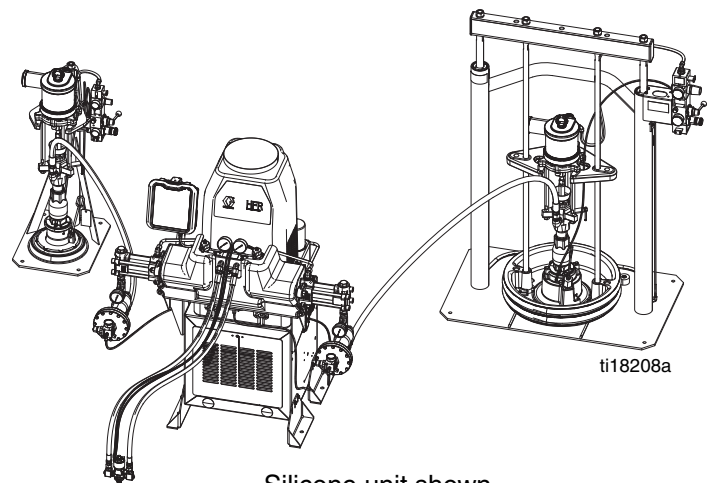

Contents

Related Manuals	3
Models	4
HFR-Laminate (HFRL)	4
HFR-Silicone (HFRS)	6
Warnings	10
Important Two-Component Material Information	14
Isocyanate Conditions	14
Material Self-ignition	14
Keep Components A (Red) and B (Blue) Separate 14	
Moisture Sensitivity of Isocyanates	14
Changing Materials	14
A (Red) and B (Blue) Components	15
Operation	16
Shutdown	16
Pressure Relief Procedure	16
Flushing	17
Repair	18
Pumpline	18
Hydraulic Power Pack Repair	25
Replace Power Supply	31
Replace Circuit Breaker	31

Parts	32
HFRL Models	32
HFRS Models	34
Base Module	40
Power Pack Module	44
Hydraulic DC Power Pack Module, 257442	46
Power Modules, 24M034 & 24M035	48
Power Panels, 24M030 & 24M031	50
Fluid Outlet Modules, 24M167 & 24M168	52
Fluid Manifolds, 255629 & 289999	54
Fluid Inlet Assembly, 24M129 (HFRL)	56
Fluid Inlet Assemblies, 24M132 & 24M133 (HFRS) 58	
Dispense Hose Assembly Kits	60
Inlet Hose Assembly Kits	62
Lubrication Kit, 24M154	63
Logic Drawings	64
230V, 1 Phase	64
400V, 3 Phase	65
DC Hydraulic Power Pack	66
Motor Control Module (MCM)	67
Accessories	69
Technical Data	70
Motor Control Module Technical Data	71
Graco Standard Warranty	72
Graco Information	72

Related Manuals

Manuals are available at www.graco.com.

Component manuals in U.S. English:

System Manuals	
3A2175	HFRL and HFRS Setup-Operation
Pumpline Manuals	
3A0019	Z-Series Chemical Pumps Instructions-Parts
3A0020	HFR™ Hydraulic Actuator Instructions-Parts
Feed System Manuals	
3A0235	Feed Supply Kits Instructions-Parts
Dispense Valve Manuals	
312185	MD2 Valve, Instructions-Parts
Accessory Manuals	
3A1149	HFR Discrete Gateway Module Kits Manual

Models

HFR-Laminate (HFRL)

HFRL models are designed for use with low viscosity, unheated urethane laminating adhesives at flow rates of up to 30 cc/sec (4 lb/min) @ 1500 psi (10 MPa, 103 bar).

A Pump Size	B Pump Size	cc/cycle	Required cpm@ Flow**	Max Flow † cc/sec (lb/min) @ 1500 psi (10 MPa, 103 bar)	Ratio	
160	86	246	8	30 (4)	1.86	
100	86	186	10		1.16	
86	80	166	11		1.08	
80	80	160	12		1.00	
80	65	145	13		1.23	
80	60	140	13		1.33	
80	50	130	14		1.60	
86	40	126	15		2.15	
60	50	110	17		1.20	
65	40	105	18		1.63	
60	40	100	19		1.50	
60	25	85	20		28 (3.7)	2.40
50	30	80	20		26 (3.5)	1.67
50	25	75	20	25 (3.3)	2.00	
50	20	70	20	23 (3.1)	2.50	

** Cycle rate should be between 8 and 20 cycles per minute. Max flow rate is determined for continuous service at 120°F (39°C) at stated cpm and pressure. Higher cycle rates are possible at lower temperatures/pressures and intermittent use. Lower cycle rates may be possible, but should be tested under application conditions.

† Dispense rate in excess of max flow and pressure may result in an elevated temperature of the hydraulic system, resulting in a thermal shutdown (T4H1). Other system models are available for sustained flow rates and pressures in excess of above.

HFRL Models

Part Number	Description
HFRL01	HFR for Lamination, 230/1, 1.00:1, 80/80, Carbon Steel
HFRL02	HFR for Lamination, 230/1, 1.08:1, 86/80, Carbon Steel
HFRL03	HFR for Lamination, 230/1, 1.16:1, 100/86, Carbon Steel
HFRL04	HFR for Lamination, 230/1, 1.20:1, 60/50, Carbon Steel
HFRL05	HFR for Lamination, 230/1, 1.23:1, 80/65, Carbon Steel
HFRL06	HFR for Lamination, 230/1, 1.33:1, 80/60, Carbon Steel
HFRL07	HFR for Lamination, 230/1, 1.50:1, 60/40, Carbon Steel
HFRL08	HFR for Lamination, 230/1, 1.60:1, 80/50, Carbon Steel
HFRL09	HFR for Lamination, 230/1, 1.63:1, 65/40, Carbon Steel
HFRL10	HFR for Lamination, 230/1, 1.67:1, 50/30, Carbon Steel
HFRL11	HFR for Lamination, 230/1, 1.86:1, 160/86, Carbon Steel
HFRL12	HFR for Lamination, 230/1, 2.00:1, 50/25, Carbon Steel
HFRL13	HFR for Lamination, 230/1, 2.15:1, 86/40, Carbon Steel
HFRL14	HFR for Lamination, 230/1, 2.40:1, 60/25, Carbon Steel
HFRL15	HFR for Lamination, 230/1, 2.5:1, 50/20, Carbon Steel
HFRL16 ★✘	HFR for Lamination, 400/3, 1.00:1, 80/80, Carbon Steel
HFRL17 ★✘	HFR for Lamination, 400/3, 1.08:1, 86/80, Carbon Steel
HFRL18 ★✘	HFR for Lamination, 400/3, 1.16:1, 100/86, Carbon Steel
HFRL19 ★✘	HFR for Lamination, 400/3, 1.20:1, 60/50, Carbon Steel
HFRL20 ★✘	HFR for Lamination, 400/3, 1.23:1, 80/65, Carbon Steel
HFRL21 ★✘	HFR for Lamination, 400/3, 1.33:1, 80/60, Carbon Steel
HFRL22 ★✘	HFR for Lamination, 400/3, 1.50:1, 60/40, Carbon Steel

Part Number	Description
HFRL23 ★✘	HFR for Lamination, 400/3, 1.60:1, 80/50, Carbon Steel
HFRL24 ★✘	HFR for Lamination, 400/3, 1.63:1, 65/40, Carbon Steel
HFRL25 ★✘	HFR for Lamination, 400/3, 1.67:1, 50/30, Carbon Steel
HFRL26 ★✘	HFR for Lamination, 400/3, 1.86:1, 160/86, Carbon Steel
HFRL27 ★✘	HFR for Lamination, 400/3, 2.00:1, 50/25, Carbon Steel
HFRL28 ★✘	HFR for Lamination, 400/3, 2.15:1, 86/40, Carbon Steel
HFRL29 ★✘	HFR for Lamination, 400/3, 2.40:1, 60/25, Carbon Steel
HFRL30 ★✘	HFR for Lamination, 400/3, 2.5:1, 50/20, Carbon Steel

★  approved.

✘ See **400 V Power Requirements**.

400 V Power Requirements

- 400 V systems are intended for International voltage requirements. Not for voltage requirements in North America.
- If a 400 volt configuration is operated in North America, a special transformer rated for 400 V ("Y" configuration (4 wire)) may be required.
- North America mostly employs a 3 wire or Delta configuration. The two configurations are not interchangeable.

HFR-Silicone (HFRS)

HFRS models are designed for use with high viscosity, unheated silicone adhesives at flow rates of up to 20 cc/sec (3 lb/min) @ 2500 psi (17 MPa, 172 bar). The equipment can be run at up to 20 cycles per minute continuous duty.

A Pump Size	B Pump Size	cc/cycle	Required cpm@ Maximum Flow**	Minimum Flow † cc/sec	Maximum Flow † cc/sec	Ratio
10	100	110	11	5.6	20	10.00
15	80	95	12.5	4.8	20	5.33
40	40	80	15	4	20	1.00
10	60	70	17	3.6	20	6.00
20	40	60	20	3	20	2.00
10	40	50	20	2.5	16.7	4.00
10	10	20	12	1	4	1.00

** Cycle rate should be between 3 and 20 cycles per minute. Max flow rate is determined for continuous service at 120°F (39°C) at stated cpm and pressure. Higher cycle rates are possible at lower temperatures/pressures and intermittent use. Lower cycle rates may be possible, but should be tested under application conditions.

† Flow rates are established @ 2500 psi (17 MPa, 172 bar). Dispense rate in excess of max flow and pressure may result in an elevated temperature of the hydraulic system, resulting in a thermal shutdown (T4H1). Other system models are available for sustained flow rates and pressures in excess of above.

HFRS Models

Part Number	Description
HFRS01	HFR for Silicone, 230/1, 1:1, Carbon Steel, 55/55 Feed, (10/10 pumps)
HFRS02	HFR for Silicone, 230/1, 1:1, Carbon Steel, 5/5 Feed, (10/10 pumps)
HFRS03 ★✘	HFR for Silicone, 400/3, 1:1, Carbon Steel, 55/55 Feed, (10/10 pumps)
HFRS04 ★✘	HFR for Silicone, 400/3, 1:1, Carbon Steel, 5/5 Feed, (10/10 pumps)
HFRS05	HFR for Silicone, 230/1, 1:1, Stainless Steel, 55/55 Feed, (10/10 pumps)
HFRS06	HFR for Silicone, 230/1, 1:1, Stainless Steel, 5/5 Feed, (10/10 pumps)
HFRS07 ★✘	HFR for Silicone, 400/3, 1:1, Stainless Steel, 55/55 Feed, (10/10 pumps)
HFRS08 ★✘	HFR for Silicone, 400/3, 1:1, Stainless Steel, 5/5 Feed, (10/10 pumps)
HFRS09	HFR for Silicone, 230/1, 4:1, Carbon Steel, 55/55 Feed
HFRS10	HFR for Silicone, 230/1, 4:1, Carbon Steel, 55/5 Feed
HFRS11	HFR for Silicone, 230/1, 4:1, Carbon Steel, 5/5 Feed
HFRS12 ★✘	HFR for Silicone, 400/3, 4:1, Carbon Steel, 55/55 Feed
HFRS13 ★✘	HFR for Silicone, 400/3, 4:1, Carbon Steel, 55/5 Feed
HFRS14 ★✘	HFR for Silicone, 400/3, 4:1, Carbon Steel, 5/5 Feed
HFRS15	HFR for Silicone, 230/1, 4:1, Stainless Steel, 55/55 Feed
HFRS16	HFR for Silicone, 230/1, 4:1, Stainless Steel, 55/5 Feed
HFRS17	HFR for Silicone, 230/1, 4:1, Stainless Steel, 5/5 Feed
HFRS18 ★✘	HFR for Silicone, 400/3, 4:1, Stainless Steel, 55/55 Feed
HFRS19 ★✘	HFR for Silicone, 400/3, 4:1, Stainless Steel, 55/5 Feed
HFRS20 ★✘	HFR for Silicone, 400/3, 4:1, Stainless Steel, 5/5 Feed
HFRS21	HFR for Silicone, 230/1, 5.33:1, Carbon Steel, 55/55 Feed
HFRS22	HFR for Silicone, 230/1, 5.33:1, Carbon Steel, 55/5 Feed

Part Number	Description
HFRS23	HFR for Silicone, 230/1, 5.33:1, Carbon Steel, 5/5 Feed
HFRS24 ★✘	HFR for Silicone, 400/3, 5.33:1, Carbon Steel, 55/55 Feed
HFRS25 ★✘	HFR for Silicone, 400/3, 5.33:1, Carbon Steel, 55/5 Feed
HFRS26 ★✘	HFR for Silicone, 400/3, 5.33:1, Carbon Steel, 5/5 Feed
HFRS27	HFR for Silicone, 230/1, 5.33:1, Stainless Steel, 55/55 Feed
HFRS28	HFR for Silicone, 230/1, 5.33:1, Stainless Steel, 55/5 Feed
HFRS29	HFR for Silicone, 230/1, 5.33:1, Stainless Steel, 5/5 Feed
HFRS30 ★✘	HFR for Silicone, 400/3, 5.33:1, Stainless Steel, 55/55 Feed
HFRS31 ★✘	HFR for Silicone, 400/3, 5.33:1, Stainless Steel, 55/5 Feed
HFRS32 ★✘	HFR for Silicone, 400/3, 5.33:1, Stainless Steel, 5/5 Feed
HFRS33	HFR for Silicone, 230/1, 6:1, Carbon Steel, 55/55 Feed
HFRS34	HFR for Silicone, 230/1, 6:1, Carbon Steel, 55/5 Feed
HFRS35	HFR for Silicone, 230/1, 6:1, Carbon Steel, 5/5 Feed
HFRS36 ★✘	HFR for Silicone, 400/3, 6:1, Carbon Steel, 55/55 Feed
HFRS37 ★✘	HFR for Silicone, 400/3, 6:1, Carbon Steel, 55/5 Feed
HFRS38 ★✘	HFR for Silicone, 400/3, 6:1, Carbon Steel, 5/5 Feed
HFRS39	HFR for Silicone, 230/1, 6:1, Stainless Steel, 55/55 Feed
HFRS40	HFR for Silicone, 230/1, 6:1, Stainless Steel, 55/5 Feed
HFRS41	HFR for Silicone, 230/1, 6:1, Stainless Steel, 5/5 Feed
HFRS42 ★✘	HFR for Silicone, 400/3, 6:1, SS 55/55 Feed
HFRS43 ★✘	HFR for Silicone, 400/3, 6:1, Stainless Steel, 55/5 Feed
HFRS44 ★✘	HFR for Silicone, 400/3, 6:1, Stainless Steel, 5/5 Feed

Part Number	Description
HFRS45	HFR for Silicone, 230/1, 10:1, Carbon Steel, 55/55 Feed
HFRS46	HFR for Silicone, 230/1, 10:1, Carbon Steel, 55/5 Feed
HFRS47	HFR for Silicone, 230/1, 10:1, Carbon Steel, 5/5 Feed
HFRS48 ★✘	HFR for Silicone, 400/3, 10:1, Carbon Steel, 55/55 Feed
HFRS49 ★✘	HFR for Silicone, 400/3, 10:1, Carbon Steel, 55/5 Feed
HFRS50 ★✘	HFR for Silicone, 400/3, 10:1, Carbon Steel, 5/5 Feed
HFRS51	HFR for Silicone, 230/1, 10:1, Stainless Steel, 55/55 Feed
HFRS52	HFR for Silicone, 230/1, 10:1, Stainless Steel, 55/5 Feed
HFRS53	HFR for Silicone, 230/1, 10:1, Stainless Steel, 5/5 Feed
HFRS54 ★✘	HFR for Silicone, 400/3, 10:1, Stainless Steel, 55/55 Feed
HFRS55 ★✘	HFR for Silicone, 400/3, 10:1, Stainless Steel, 55/5 Feed
HFRS56 ★✘	HFR for Silicone, 400/3, 10:1, Stainless Steel, 5/5 Feed
HFRS57	HFR for Silicone, 230/1, 2:1, Carbon Steel, 55/55 Feed
HFRS58 ★✘	HFR for Silicone, 230/1, 2:1, Carbon Steel, 55/5 Feed
HFRS59	HFR for Silicone, 230/1, 2:1, Carbon Steel, 5/5 Feed
HFRS60 ★✘	HFR for Silicone, 400/3, 2:1, Carbon Steel, 55/55 Feed
HFRS61	HFR for Silicone, 400/3, 2:1, Carbon Steel, 55/5 Feed
HFRS62 ★✘	HFR for Silicone, 400/3, 2:1, Carbon Steel, 5/5 Feed
HFRS63	HFR for Silicone, 230/1, 2:1, Stainless Steel, 55/55 Feed
HFRS64 ★✘	HFR for Silicone, 230/1, 2:1, Stainless Steel, 55/5 Feed
HFRS65	HFR for Silicone, 230/1, 2:1, Stainless Steel, 5/5 Feed
HFRS66 ★✘	HFR for Silicone, 400/3, 2:1, Stainless Steel, 55/55 Feed

Part Number	Description
HFRS67	HFR for Silicone, 400/3, 2:1, Stainless Steel, 55/5 Feed
HFRS68 ★✘	HFR for Silicone, 400/3, 2:1, Stainless Steel, 5/5 Feed
HFRS69	HFR for Silicone, 230/1, 1:1, Carbon Steel, No Feed, (10/10 pumps)
HFRS70 ★✘	HFR for Silicone, 400/3, 1:1, Carbon Steel, No Feed, (10/10 pumps)
HFRS71	HFR for Silicone, 230/1, 1:1, Stainless Steel, No Feed, (10/10 pumps)
HFRS72 ★✘	HFR for Silicone, 400/3, 1:1, Stainless Steel, No Feed, (10/10 pumps)
HFRS73	HFR for Silicone, 230/1, 2:1, Carbon Steel, No Feed
HFRS74 ★✘	HFR for Silicone, 400/3, 2:1, Carbon Steel, No Feed
HFRS75	HFR for Silicone, 230/1, 2:1, Stainless Steel, No Feed
HFRS76 ★✘	HFR for Silicone, 400/3, 2:1, Stainless Steel, No Feed
HFRS77	HFR for Silicone, 230/1, 4:1, Carbon Steel, No Feed
HFRS78 ★✘	HFR for Silicone, 400/3, 4:1, Carbon Steel, No Feed
HFRS79	HFR for Silicone, 230/1, 4:1, Stainless Steel, No Feed
HFRS80 ★✘	HFR for Silicone, 400/3, 4:1, Stainless Steel, No Feed
HFRS81	HFR for Silicone, 230/1, 5.33:1, Carbon Steel, No Feed
HFRS82 ★✘	HFR for Silicone, 400/3, 5.33:1, Carbon Steel, No Feed
HFRS83	HFR for Silicone, 230/1, 5.33:1, Stainless Steel, No Feed
HFRS84 ★✘	HFR for Silicone, 400/3, 5.33:1, Stainless Steel, No Feed
HFRS85	HFR for Silicone, 230/1, 6:1, Carbon Steel, No Feed
HFRS86 ★✘	HFR for Silicone, 400/3, 6:1, Carbon Steel, No Feed
HFRS87	HFR for Silicone, 230/1, 6:1, Stainless Steel, No Feed
HFRS88 ★✘	HFR for Silicone, 400/3, 6:1, Stainless Steel, No Feed

Part Number	Description
HFRS89	HFR for Silicone, 230/1, 10:1, Carbon Steel, No Feed
HFRS90 ★✘	HFR for Silicone, 400/3, 10:1, Carbon Steel, No Feed
HFRS91	HFR for Silicone, 230/1, 10:1, Stainless Steel, No Feed
HFRS92 ★✘	HFR for Silicone, 400/3, 10:1, Stainless Steel, No Feed
HFRS93	HFR for Silicone, 230/1, 1:1, Carbon Steel, 55/55 Feed, (40/40 pumps)
HFRS94	HFR for Silicone, 230/1, 1:1, Carbon Steel, 5/5 Feed, (40/40 pumps)
HFRS95 ★✘	HFR for Silicone, 400/3, 1:1, Carbon Steel, 55/55 Feed, (40/40 pumps)
HFRS96 ★✘	HFR for Silicone, 400/3, 1:1, Carbon Steel, 5/5 Feed, (40/40 pumps)
HFRS97	HFR for Silicone, 230/1, 1:1, Stainless Steel, 55/55 Feed, (40/40 pumps)
HFRS98	HFR for Silicone, 230/1, 1:1, Stainless Steel, 5/5 Feed, (40/40 pumps)
HFRS99 ★✘	HFR for Silicone, 400/3, 1:1, Stainless Steel, 55/55 Feed, (40/40 pumps)
HFRSA0 ★✘	HFR for Silicone, 400/3, 1:1, Stainless Steel, 5/5 Feed, (40/40 pumps)
HFRSA1	HFR for Silicone, 230/1, 1:1, Carbon Steel, No Feed, (40/40 pumps)
HFRSA2 ★✘	HFR for Silicone, 400/3, 1:1, Carbon Steel, No Feed, (40/40 pumps)
HFRSA3	HFR for Silicone, 230/1, 1:1, Stainless Steel, No Feed, (40/40 pumps)
HFRSA4 ★✘	HFR for Silicone, 400/3, 1:1, Stainless Steel, No Feed, (40/40 pumps)

400 V Power Requirements





- 400 V systems are intended for International voltage requirements. Not for voltage requirements in North America.
- If a 400 volt configuration is operated in North America, a special transformer rated for 400 V ("Y" configuration (4 wire)) may be required.
- North America mostly employs a 3 wire or Delta configuration. The two configurations are not interchangeable.

★  approved.

✘ See **400 V Power Requirements**.

Warnings

The following warnings are for the setup, use, grounding, maintenance, and repair of this equipment. The exclamation point symbol alerts you to a general warning and the hazard symbol refers to procedure-specific risk. Refer back to these warnings. Additional, product-specific warnings may be found throughout the body of this manual where applicable.

 WARNING	
	<p>ELECTRIC SHOCK HAZARD</p> <p>This equipment must be grounded. Improper grounding, setup, or usage of the system can cause electric shock.</p> <ul style="list-style-type: none"> • Turn off and disconnect power at main switch before disconnecting any cables and before servicing equipment. • Connect only to grounded power source. • All electrical wiring must be done by a qualified electrician and comply with all local codes and regulations.
	<p>TOXIC FLUID OR FUMES HAZARD</p> <p>Toxic fluids or fumes can cause serious injury or death if splashed in the eyes or on skin, inhaled, or swallowed.</p> <ul style="list-style-type: none"> • Read MSDSs to know the specific hazards of the fluids you are using. • Store hazardous fluid in approved containers, and dispose of it according to applicable guidelines. • Always wear chemically impermeable gloves when spraying, dispensing, or cleaning equipment.
	<p>PERSONAL PROTECTIVE EQUIPMENT</p> <p>You must wear appropriate protective equipment when operating, servicing, or when in the operating area of the equipment to help protect you from serious injury, including eye injury, hearing loss, inhalation of toxic fumes, and burns. This equipment includes but is not limited to:</p> <ul style="list-style-type: none"> • Protective eyewear, and hearing protection. • Respirators, protective clothing, and gloves as recommended by the fluid and solvent manufacturer.
	<p>SKIN INJECTION HAZARD</p> <p>High-pressure fluid from dispensing device, hose leaks, or ruptured components will pierce skin. This may look like just a cut, but it is a serious injury that can result in amputation. Get immediate surgical treatment.</p> <ul style="list-style-type: none"> • Do not point dispensing device at anyone or at any part of the body. • Do not put your hand over the fluid outlet. • Do not stop or deflect leaks with your hand, body, glove, or rag. • Follow the Pressure Relief Procedure when you stop dispensing and before cleaning, checking, or servicing equipment. • Tighten all fluid connections before operating the equipment. • Check hoses and couplings daily. Replace worn or damaged parts immediately.

 **WARNING**
**FIRE AND EXPLOSION HAZARD**

Flammable fumes, such as solvent and paint fumes, in **work area** can ignite or explode. To help prevent fire and explosion:

- Use equipment only in well ventilated area.
- Eliminate all ignition sources; such as pilot lights, cigarettes, portable electric lamps, and plastic drop cloths (potential static arc).
- Keep work area free of debris, including solvent, rags and gasoline.
- Do not plug or unplug power cords, or turn power or light switches on or off when flammable fumes are present.
- Ground all equipment in the work area. See **Grounding** instructions.
- Use only grounded hoses.
- Hold gun firmly to side of grounded pail when triggering into pail.
- If there is static sparking or you feel a shock, **stop operation immediately**. Do not use equipment until you identify and correct the problem.
- Keep a working fire extinguisher in the work area.

**PRESSURIZED EQUIPMENT HAZARD**

Fluid from the gun/dispense valve, leaks, or ruptured components can splash in the eyes or on skin and cause serious injury.

- Follow the **Pressure Relief Procedure** when you stop spraying and before cleaning, checking, or servicing equipment.
- Tighten all fluid connections before operating the equipment.
- Check hoses, tubes, and couplings daily. Replace worn or damaged parts immediately.

**EQUIPMENT MISUSE HAZARD**

Misuse can cause death or serious injury.

- Do not operate the unit when fatigued or under the influence of drugs or alcohol.
- Do not exceed the maximum working pressure or temperature rating of the lowest rated system component. See **Technical Data** in all equipment manuals.
- Use fluids and solvents that are compatible with equipment wetted parts. See **Technical Data** in all equipment manuals. Read fluid and solvent manufacturer's warnings. For complete information about your material, request MSDS from distributor or retailer.
- Do not leave the work area while equipment is energized or under pressure. Turn off all equipment and follow the **Pressure Relief Procedure** when equipment is not in use.
- Check equipment daily. Repair or replace worn or damaged parts immediately with genuine manufacturer's replacement parts only.
- Do not alter or modify equipment.
- Use equipment only for its intended purpose. Call your distributor for information.
- Route hoses and cables away from traffic areas, sharp edges, moving parts, and hot surfaces.
- Do not kink or over bend hoses or use hoses to pull equipment.
- Keep children and animals away from work area.
- Comply with all applicable safety regulations.

 **WARNING**



MOVING PARTS HAZARD

Moving parts can pinch, cut or amputate fingers and other body parts.



- Keep clear of moving parts.
- Do not operate equipment with protective guards or covers removed.
- Pressurized equipment can start without warning. Before checking, moving, or servicing equipment, follow the **Pressure Relief Procedure** and disconnect all power sources.



BURN HAZARD

Equipment surfaces and fluid that's heated can become very hot during operation. To avoid severe burns:

- Do not touch hot fluid or equipment.

Important Two-Component Material Information

Isocyanate Conditions



Spraying or dispensing materials containing isocyanates creates potentially harmful mists, vapors, and atomized particulates.

Read material manufacturer's warnings and material MSDS to know specific hazards and precautions related to isocyanates.

Prevent inhalation of isocyanate mists, vapors, and atomized particulates by providing sufficient ventilation in the work area. If sufficient ventilation is not available, a supplied-air respirator is required for everyone in the work area.

To prevent contact with isocyanates, appropriate personal protective equipment, including chemically impermeable gloves, boots, aprons, and goggles, is also required for everyone in the work area.

Moisture Sensitivity of Isocyanates

Isocyanates (ISO) are catalysts used in two component foam and polyurea coatings. ISO will react with moisture (such as humidity) to form small, hard, abrasive crystals, which become suspended in the fluid. Eventually a film will form on the surface and the ISO will begin to gel, increasing in viscosity. If used, this partially cured ISO will reduce performance and the life of all wetted parts.

NOTE: The amount of film formation and rate of crystallization varies depending on the blend of ISO, the humidity, and the temperature.

To prevent exposing ISO to moisture:

- Always use a sealed container with a desiccant dryer in the vent, or a nitrogen atmosphere. **Never** store ISO in an open container.
- Keep the ISO lube pump reservoir (if installed) filled with IsoGuard Select™, part 24F516. The lubricant creates a barrier between the ISO and the atmosphere.
- Use moisture-proof hoses specifically designed for ISO, such as those supplied with your system.
- Never use reclaimed solvents, which may contain moisture. Always keep solvent containers closed when not in use.
- Never use solvent on one side if it has been contaminated from the other side.
- Always lubricate threaded parts with ISO pump oil or grease when reassembling.

Material Self-ignition



Some materials may become self-igniting if applied too thickly. Read material manufacturer's warnings and material MSDS.

Keep Components A (Red) and B (Blue) Separate



Cross-contamination can result in cured material in fluid lines which could cause serious injury or damage equipment. To prevent cross-contamination of the equipment's wetted parts, **never** interchange component A (Red) and component B (Blue) parts.

Changing Materials

- When changing materials, flush the equipment multiple times to ensure it is thoroughly clean.
- Always clean the fluid inlet strainers after flushing.
- Check with your material manufacturer for chemical compatibility.
- Most materials use ISO on the A (Red) side, but some use ISO on the B (Blue) side. See the following section.

A (Red) and B (Blue) Components

IMPORTANT!

Material suppliers can vary in how they refer to plural component materials.

Be aware that when standing in front of the manifold on proportioner:

- Component A (Red) is on the left side.
- Component B (Blue) is on the right side.

For all machines:

- The A (Red) side is intended for ISO, hardeners, and catalysts.
- If one of the materials being used is moisture-sensitive, that material should always be in the A (Red) side.
- The B (Blue) side is intended for polyols, resins, and bases.

For HFRS Systems:

The high volume material is typically the ISO and is located on the A (Red) side. Some material chemistries may have an ISO which is the low volume material. The ISO must always be in the A (Red) side containing the Isolube.

NOTE: For HFRL Systems:

The high volume material will always be the B (Blue) side. Typical Installation.

Operation

Shutdown



1. Park pumps.

a. From the Home screen, press  and select Standby mode.

b. Press . Material will dispense. Pump will park automatically. Once pump is parked, pump will stop moving.

If a dispense gun with a trigger is installed, pulling the trigger will begin a park operation. Material will dispense.

2. Press the enable/disable key on the ADM  to disable the ADM.

3. Turn main power switch (MP) to OFF position.

4. Close A (Red) and B (Blue) fluid supply valves (FV), if equipped, or remove fluid pressure at supply device.

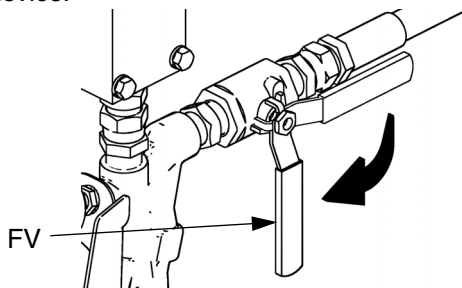

ti9883a1

5. Perform **Pressure Relief Procedure** on page 16.

6. Shut down feed pumps as required. See feed pump manual.

Pressure Relief Procedure



NOTICE

The fittings on the pressure relief hoses are zinc plated carbon steel. The hose cores are cured with sulfur. Check your materials for compatibility with zinc plating and sulfur before reusing any material that passed through them, as it may inhibit curing.

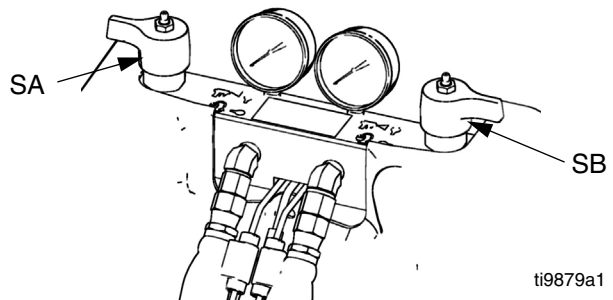

1. Shut off feed pumps and agitator, if used.
2. Turn PRESSURE RELIEF/DISPENSE valves (SA, SB) to PRESSURE RELIEF/CIRCULATION . Route fluid to waste containers or supply tanks. Ensure gauges drop to 0.



ti9879a1

3. **For models with an dispense valve with a safety lock,** engage gun safety lock.
4. Relieve pressure in dispense valve. See dispense valve manual.

Flushing

						
<p>Flush equipment only in a well-ventilated area. Do not dispense flammable fluids. Do not turn on heaters while flushing with flammable solvents.</p>						

- Flush out old fluid with new fluid, or flush out old fluid with a compatible solvent before introducing new fluid.
- Use the lowest possible pressure when flushing.
- All fluid components are compatible with common solvents. Use only moisture-free solvents. See **Technical Data** on page **70** for list of wetted components to verify compatibility of solvent with wetted materials. See solvent manufacturers information for material compatibility.
- To flush feed hoses, pumps, and heaters separately from heated hoses, set PRESSURE RELIEF/DIS-PENSE valves (SA, SB) to PRESSURE

RELIEF/CIRCULATION  . Flush through bleed lines (N).

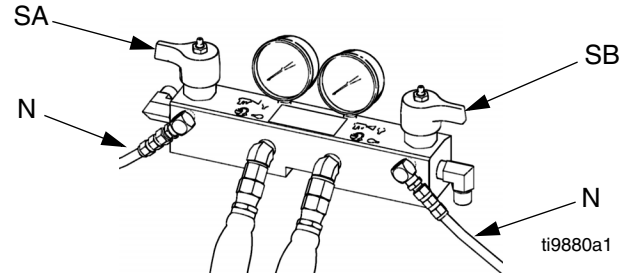

- To flush entire system, circulate through gun fluid manifold (with manifold removed from gun).
- To prevent moisture from reacting with isocyanate, always leave the system dry or filled with a moisture-free plasticizer or oil. Do not use water. See **Important Two-Component Material Information** on page **14**.
- *Solvent pails used when flushing:* follow your local code. Use only metal pails, which are conductive, placed on a grounded surface. Do not place pail on a nonconductive surface, such as paper or cardboard, which interrupts grounding continuity.
- *To maintain grounding continuity when flushing or relieving pressure,* hold a metal part of dispense gun firmly to the side of a grounded *metal* pail, then trigger gun.

Repair

Pumpline

See Z-Series Chemical Pumps manual, HFR Hydraulic Driver manuals for more detailed pumpline repair information.

Remove Chemical Pumps



This procedure removes the chemical pumps so that replacement parts can be installed. See Z-Series Chemical Pumps manual for replacement parts installation procedure.

1. Flush system, see page 17.
2. Perform **Operation**, see page 16.
3. Remove the front pump shroud.

4. Disconnect the chemical pump inlet and outlet fluid lines. Do not disconnect the fluid manifold inlet line or the fluid line connections at the heater.

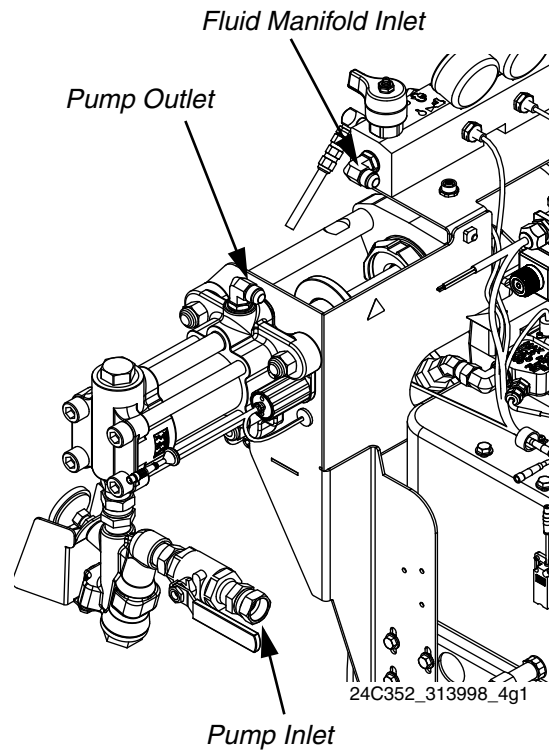

5. Unthread smaller cylinder from hydraulic driver and slide inside larger cylinder. Use punch slots in lube cylinder to aid rotation if necessary. See FIG. 1.

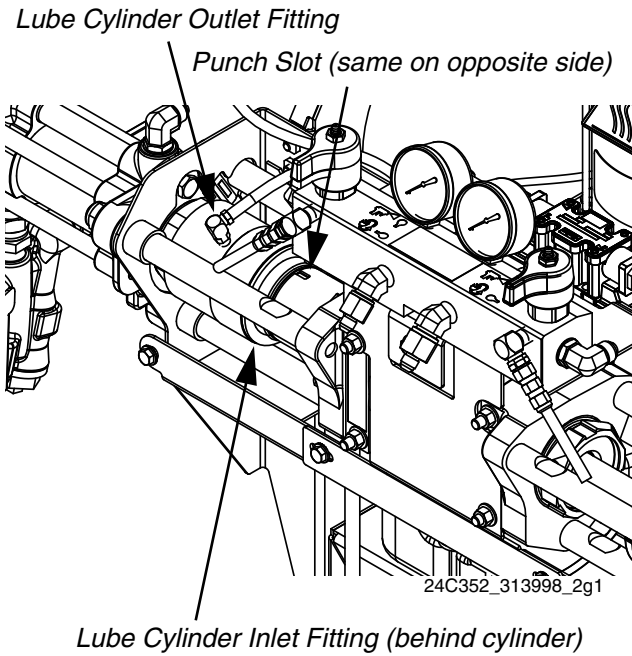

FIG. 1: Lube Cylinder

7. Remove coupler from the A and B side pump shafts. See FIG. 2.
8. Unscrew LVDT sensor assembly and spool assembly from pump outlet housing. Wipe off spool assembly. See FIG. 2.
9. Remove three nuts securing pump to tie rods. See FIG. 2.

6. Remove two shoulder bolts from LVDT collar then remove collar from B side pump shaft. See FIG. 2.

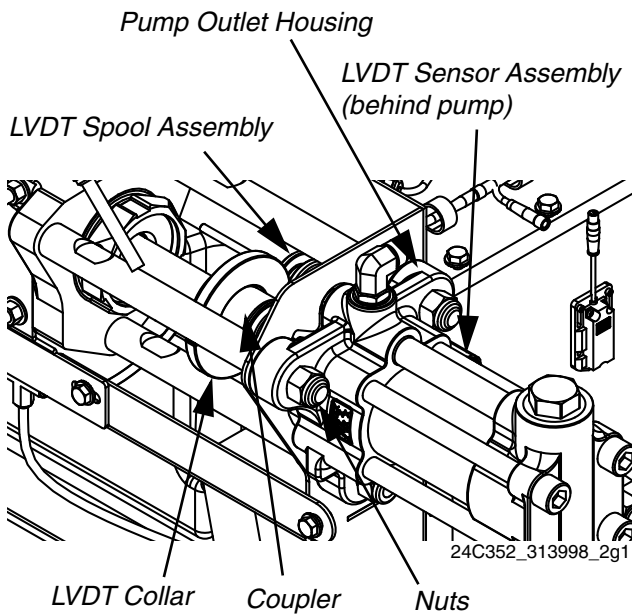

FIG. 2

Install Chemical Pumps

Reconnect or install a different size chemical pump to achieve desired ratio.

1. Install ISO lube cylinder on A side pump. Apply light coating of lubricant on o-rings on outside of small cylinder.
2. Install nuts on tie rods after the pumps have been installed. Torque to 50-60 ft-lb (68-81 N•m).
3. Install coupler on A and B side pump shafts.
4. Install LVDT Assembly.
 - a. Apply a very light coat of hydraulic oil on LVDT sensor tube and install through pump outlet housing. Install spool assembly.
 - b. Install LVDT collar on coupler and pump shaft. Ensure that the split on the LVDT collar does not ride in the spool assembly.
 - c. Apply thread sealant to shoulder bolts then install in LVDT collar. Torque to 40-50 in-lb (4.5-5.6 N•m).
5. After the IsoGuard Select cylinder has been installed on the A side pump, apply pipe sealant on cylinder outlet fitting.
6. Perform **Prime IsoGuard Select™ Cylinder** procedure, see page 20.
7. Reconnect inlet and outlet fluid lines.

Prime IsoGuard Select™ Cylinder

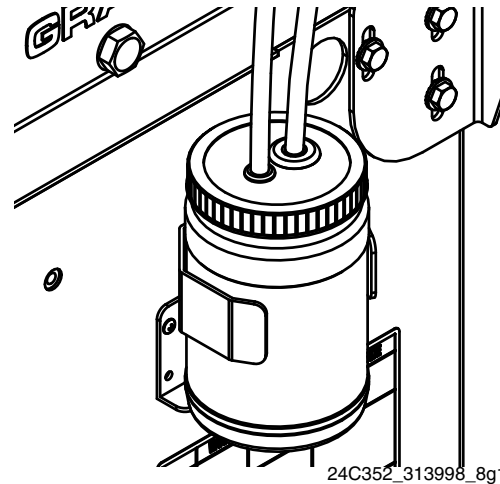

FIG. 3: IsoGuard Select System

NOTE: The IsoGuard Select cylinder is installed on all HFRL systems and is available separately as kit 24M154 for HFRS systems.

Ensure that the IsoGuard Select cylinder outlet faces upward for air to exhaust.

1. Install IsoGuard Select cylinder inlet fitting and inlet tube into bottom of cylinder. The inlet tube is the tube with a check valve installed in it which points in the direction of flow towards the IsoGuard Select cylinder.
2. Install IsoGuard Select cylinder outlet fitting and outlet tube into top of cylinder. The outlet tube is the tube with a check valve installed in it which points in the direction of flow away from the IsoGuard Select cylinder.
3. Remove check valve from end of outlet tube.
4. Use funnel to pour IsoGuard Select into tube to fill cylinder.
5. With check valve arrow pointing away from the IsoGuard Select cylinder, install check valve in end of outlet tube.
6. Install tubes into reservoir and install reservoir into holder.

Remove HFR Hydraulic Driver

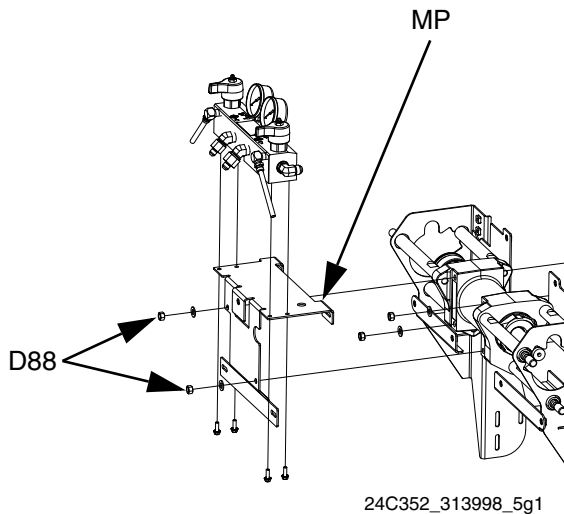
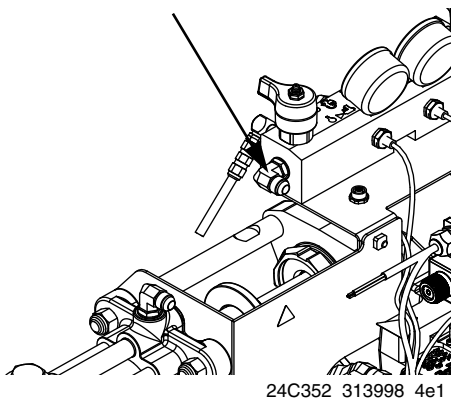

FIG. 4

This procedure removes the HFR Hydraulic Driver so replacement parts can be installed. See HFR Hydraulic Driver manual for replacement parts installation procedure.

1. Perform **Remove Chemical Pumps** procedure, see page **18**.
2. Disconnect the fluid manifold inlet lines. Do not disconnect the fluid line connections at the heater.

Fluid Manifold Inlet



3. Remove pump support brackets. Each bracket is secured with three screws at the base frame and two screws at the manifold bracket.

4. See **FIG. 4**. Remove four nuts (D88) securing hydraulic driver to hydraulic power pack. This will also loosen manifold plate (MP) from hydraulic driver. Remove manifold plate. Remove hydraulic driver.

Install HFR Hydraulic Driver

This procedure installs the hydraulic driver after replacement parts have been installed and actuator has been reassembled. See HFR Hydraulic Driver manual for replacement parts installation procedure.

1. Hang the hydraulic driver on the studs. Verify o-rings between driver and hydraulic power pack are installed and lubricated. Secure the driver with nuts and washer at bottom-left and top-right corners.
2. Install manifold bracket. Secure at top-left and bottom-right corners.
3. Install pump support brackets, torque to 300 in-lb (33.9 N•m). This will also install manifold plate (MP) to hydraulic driver.
4. Connect fluid manifold inlet lines.
5. Perform **Install Chemical Pumps** procedure, see page **20**.

Remove PowerHouse Pumpline



The Hydraulic Power Pack must be removed to perform some Hydraulic Power Pack repair procedures. In order to remove the Hydraulic Power Pack, the PowerHouse pumpline must be removed. See **Hydraulic Power Pack Repair** starting on page 25 for more information.

1. Perform **Operation** procedure, see page 16.
2. Flush the system, see page 17.
3. Disconnect the chemical pump inlet, pump outlet, and fluid manifold inlet lines. Do not disconnect the fluid line connections at the heater.

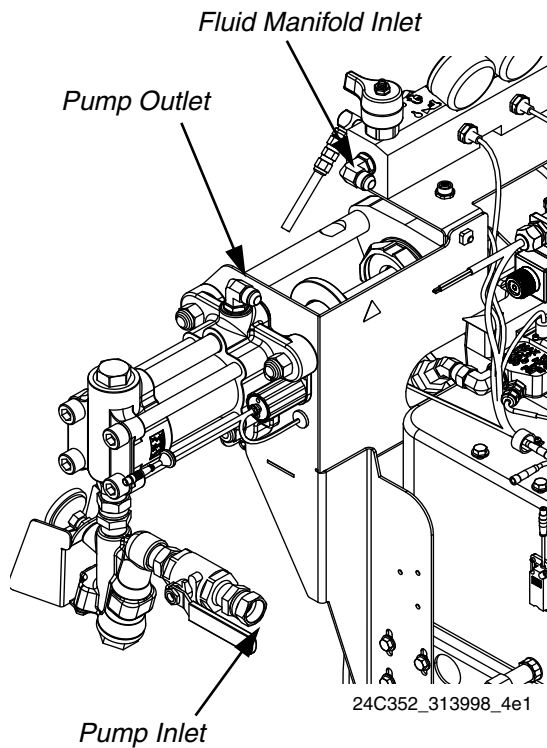

4. Remove lube cylinder inlet and outlet fittings. Let cylinder drain.

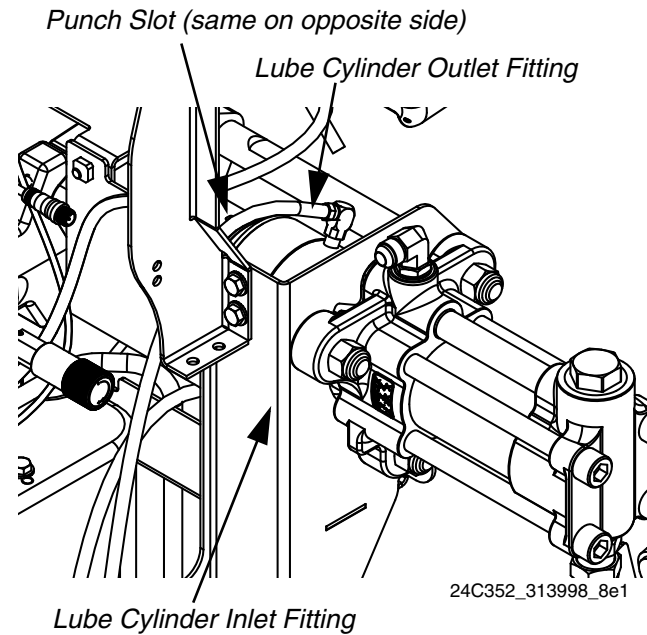

FIG. 5: Lube Cylinder, Viewed from Rear Left of Machine

5. See FIG. 6. Remove four screws securing pumpline to hydraulic power pack. This will also loosen manifold plate (MP) from hydraulic driver.

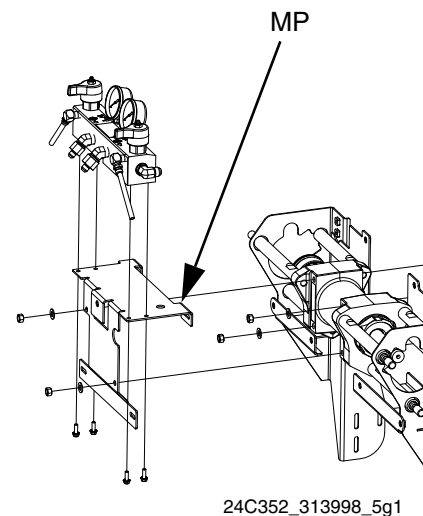

FIG. 6

6. While supporting the pumpline, remove the three bolts on each side of the machine securing the pump support brackets to the machine base. See FIG. 7. Remove pumpline.

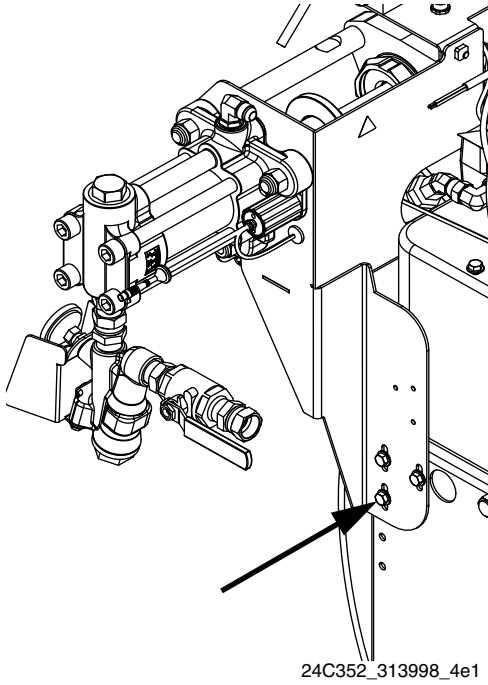
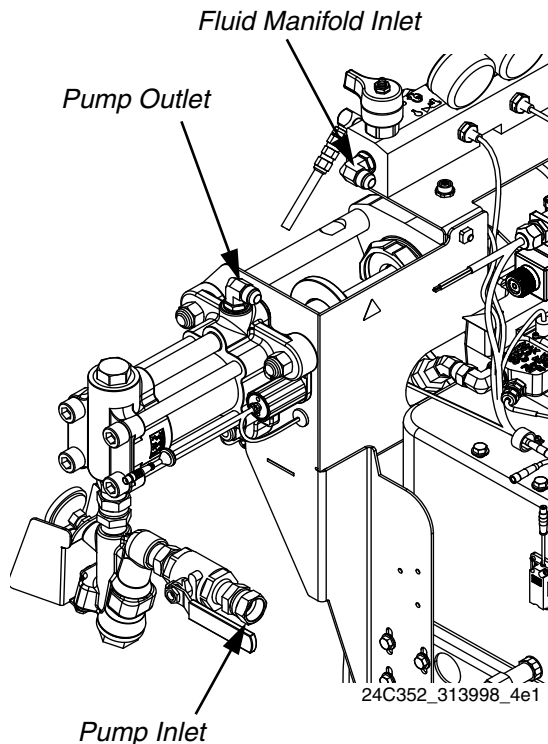

FIG. 7

Install PowerHouse Pumpline

The Hydraulic Power Pack must be removed to perform some Hydraulic Power Pack repair procedures. In order to remove the Hydraulic Power Pack, the PowerHouse pumpline must be removed. This procedure is for installing the PowerHouse pumpline at the end of the Hydraulic Power Pack Repair procedure. See **Hydraulic Power Pack Repair** starting on page 25 for more information.

1. While supporting the pumpline, install the three bolts on each side of the machine securing the pump support brackets to the machine base. See **FIG. 7**. Torque to 150 in-lb (16.9 N•m).
2. See **FIG. 6**. Align manifold plate (MP) with hydraulic driver. Align hydraulic driver with hydraulic power pack. Install four screws securing hydraulic driver to hydraulic power pack. This will also install manifold plate (MP) to hydraulic driver. Torque to 300 in-lb (33.9 N•m).
3. Install lube cylinder inlet and outlet fittings. See **FIG. 5**. Apply thread sealant to threads.
4. Perform **Prime IsoGuard Select™ Cylinder** procedure, see page 20.
5. Connect the chemical pump inlet, pump outlet, and fluid manifold inlet lines.



Hydraulic Power Pack Repair

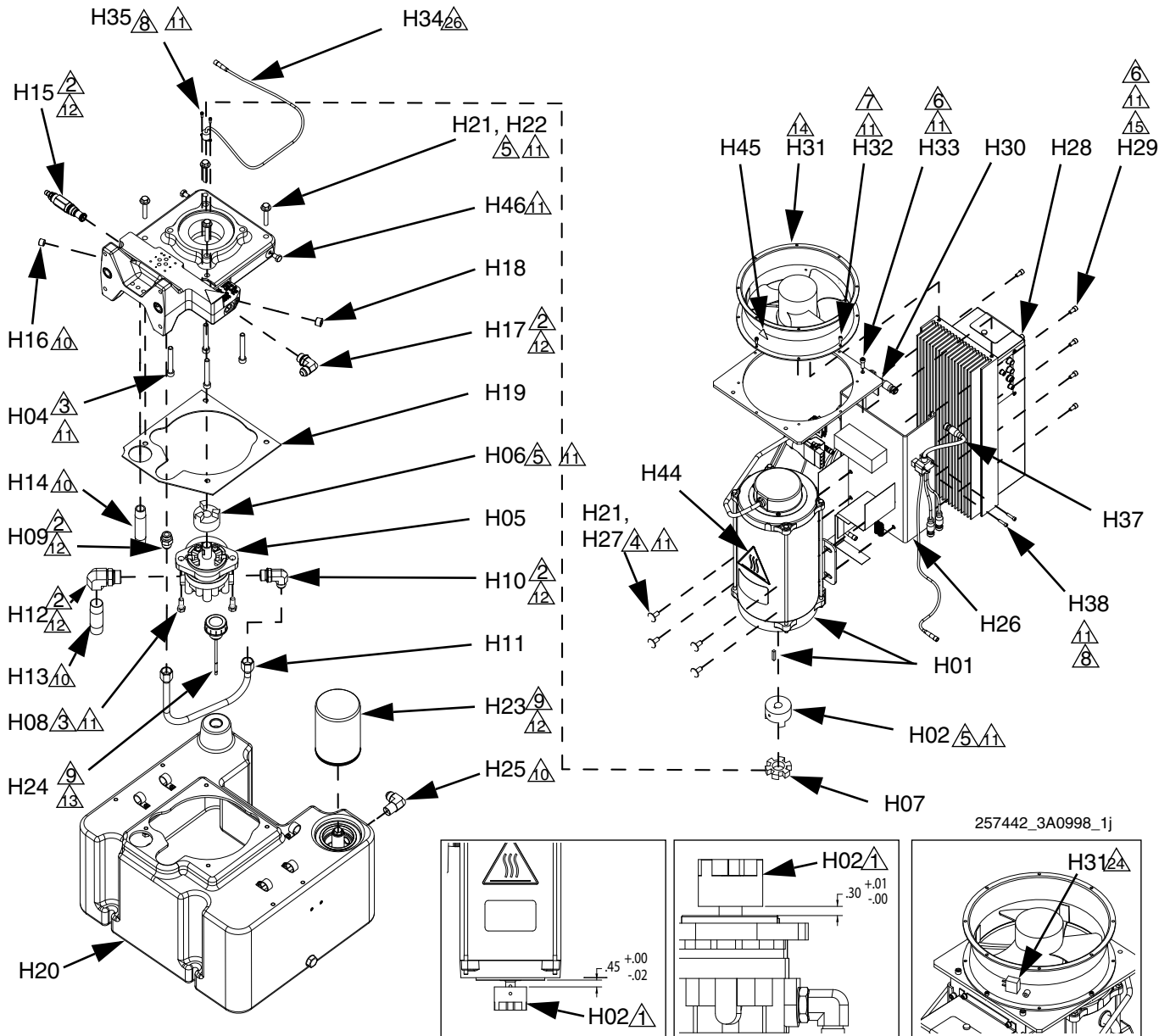

- Assemble coupler to specified dimensions prior to mounting assembly to housing.
- Torque to 40 ft-lb (54 N•m).
- Torque to 35 ft-lb (47 N•m).
- Torque to 20 ft-lb (27 N•m).
- Torque to 15 ft-lb (20 N•m).
- Torque to 10 ft-lb (14 N•m).
- Torque to 58 in-lb (6.5 N•m).

- Torque to 34 in-lb (3.8 N•m).
- Torque 1/4 turn past hand-tight.
- Apply PTFE tape on installation end only.
- Apply medium strength thread locker before assembly.
- Apply light coating of lubricant to seals.
- Fill reservoir with hydraulic fluid.

- Orient with airflow arrow pointing toward mounting bracket.
- Prior to installing Ref. 728 into Ref. 726, install Ref. 729 into Ref. 728 and adjust head 1/8 in. from surface.
- Align fan plug as shown.
- Apply thermal lubricant to contact side.

FIG. 8: Hydraulic DC Power Pack

Remove Hydraulic Power Pack Shroud

1. Remove four screws from base of shroud.
2. Lift shroud off of Hydraulic Power Pack.

Install Hydraulic Power Pack Shroud

NOTICE

Do not over-torque any item that threads into the hydraulic tank. This will strip the threads and require tank replacement.

1. Place shroud on top of Hydraulic Power Pack.
2. Install four screws securing shroud to hydraulic tank.

Replace Hydraulic Filter

Filter is located at right rear of hydraulic power pack. See **FIG. 8** on page 25.

NOTICE

If any debris falls into the hydraulic tank, the debris must be removed or machine damage will result.

1. Perform **Operation** procedure, see page 16.
2. Use compressed air to remove any loose debris around the hydraulic filter.
3. Remove new filter from wrapping.
4. Apply a light coat of hydraulic fluid to the o-ring on the face of the hydraulic filter.
5. Being careful not to allow any debris into the hydraulic tank remove old filter from tank then quickly install new filter.

Replace Fan



See **FIG. 8** on page 25.

1. Perform **Operation** procedure, see page 16.
2. **Remove Hydraulic Power Pack Shroud**, see procedure on this page.

3. Remove four screws (H32) connecting fan to mounting plate.
4. Remove fan and install new fan.
5. Install four screws (H32) connecting fan to Motor and Motor Control Module.
6. **Install Hydraulic Power Pack Shroud**, see procedure on this page.

Remove Motor Control Module



See **FIG. 8** on page 25.

1. Perform **Operation** procedure, see page 16.
2. **Remove Hydraulic Power Pack Shroud**, see procedure on this page.
3. Remove four screws (H32) connecting fan to Motor and Motor Control Module. Remove fan and mounting plate.
4. Note the location of each Motor Control Module cable then remove all electrical cables on the left and right sides of the Motor Control Module.
5. Remove six screws (H29) securing Motor Control Module in place.
6. Slowly and carefully slide the Motor Control Module up until the cable on the bottom of the Motor Control Module can be accessed and removed. Disconnect the cable.
7. Slide the Motor Control Module up and remove.

Adjust Motor Control Module Selector Switch

NOTICE

If the Motor Control Module is replaced, the selector switch must be set prior to initial startup of the Motor Control Module or damage may occur.

The Motor Control Module uses an 8-position selector switch (S) to set system maximum working pressure. See **FIG. 9**.

The system can be configured to run in two pressure ranges:



- **0-3000 psi (0-20.7 MPA, 0-207 bar):** For systems will all components rated to 3000 psi maximum working pressure or higher.
- **0-2000 psi (0-13.8 MPA, 0-138 bar):** For systems with one or more component rated less than 3000 psi maximum working pressure. For example, if the dispense valve is rated to 2500 psi, then the 0-2000 psi range must be used.

NOTE: The Motor Control Module selector switch (S) position #1 sets the system to 2000 psi maximum working pressure. Selector switch position #3 sets the system to 3000 psi maximum working pressure.

The factory setting for the Motor Control Module selector switch is position #1 to set the machine to 2000 psi if the machine is shipped with no hoses or hoses rated to 2000 psi maximum working pressure. If the machine is shipped with hoses rated to 3000 psi maximum working pressure or higher then the factory setting for the selector switch is position #3 to set the machine to 3000 psi.

The selector switch position will be properly set at the factory for new systems. When a motor control module is replaced, the selector switch must be set to the correct setting by the user prior to initial startup.

To change the maximum working pressure rating of the system in the field, all outlet components including hoses and dispense valve must be rated at or above the new system maximum working pressure rating. For example, if the new system rating will be 3000 psi, all system components must be rated to at least 3000 psi maximum working pressure.

							
<ul style="list-style-type: none"> • Do not install components rated to less than the highest pressure in the selected pressure range. For example, if the 0-2000 psi range is selected do not install items rated less than 2000 psi. If the 0-3000 psi range is selected do not install items rated less than 3000 psi. Doing so may lead to overpressurization and ruptured components. • High-pressure fluid from ruptured components will pierce skin. This may look like just a cut, but it is a serious injury that can result in amputation. Get immediate surgical treatment. 							

To set the Motor Control Module selector switch:

1. Turn machine power off.
2. Remove the access cover (D). See **FIG. 9**.
3. Set the selector switch (S).
4. Install access cover (D).

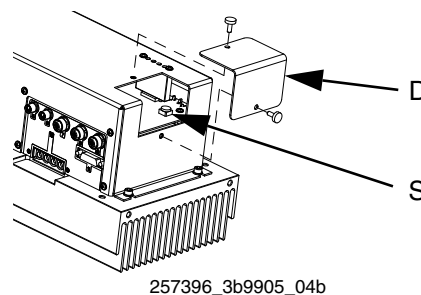

FIG. 9

Install Motor Control Module



This procedure starts assuming that the old Motor Control Module is removed from the machine. See **Remove Motor Control Module** procedure, see page 26.

See **FIG. 8** on page 25.

1. Perform **Adjust Motor Control Module Selector Switch** procedure on page 27.

NOTICE

Motor Control Module selector switch position must be set prior to startup of Motor Control Module or damage may occur.

2. Slide the Motor Control Module into the slot.
3. Attach the cable on the bottom of the Motor Control Module.
4. Install the six screws (H29) securing Motor Control Module in place.
5. Install electrical cables on left and right sides of the Motor Control Module.
6. Install four screws (H32) connecting fan to Motor and Motor Control Module. Install fan and mounting plate.
7. **Install Hydraulic Power Pack Shroud**, see procedure on page 26.

Remove Hydraulic Power Pack



The hydraulic power pack weighs up to 300 lb. To avoid serious injury due the hydraulic power pack falling, secure the hydraulic lift when raising the hydraulic power pack.

NOTICE

If any debris falls into the hydraulic tank, the debris must be removed or machine damage will result.

This procedure removes the hydraulic power pack from the machine as a single unit to enable further disassembly. User must purchase three 5/16-18 eye-bolts capable of holding 300 lb to perform this procedure.

See **FIG. 8** on page 25.

1. Perform **Operation** procedure, see page 16.
2. Perform **Remove Hydraulic Power Pack Shroud**, see procedure on page 26.
3. Perform **Remove Motor Control Module** procedure, see page 26.
4. Perform **Remove PowerHouse Pumpline** procedure, see page 22.
5. Disconnect heat exchanger inlet hose and fitting from elbow fitting. Disconnect heat exchanger outlet hose and fitting from elbow fitting.
6. Remove the two bolts (H46) from the fluid housing (H03) and replace each with a strong 5/16-18 thread eye-bolt. Install a third strong 5/16-18 eye-bolt as indicated. See **FIG. 10**. See **FIG. 8** on page 25 for full hydraulic power pack view.

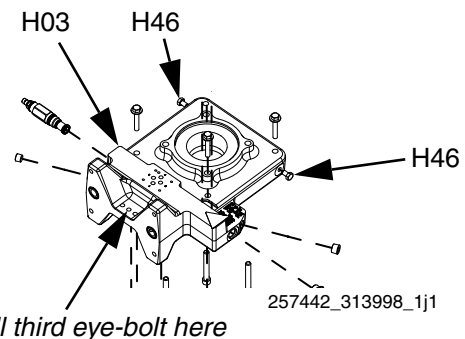

FIG. 10

7. Run a rope through the three eye-bolts and between the motor and the Motor Control Module. Secure to a hydraulic lift.
8. Remove the four bolts and washers securing the tank to the electrical enclosure. See **Power Pack Module** on page 44.
9. Lift the hydraulic power pack and place on a sturdy location capable of supporting up to 300 lbs.

Install Hydraulic Power Pack



NOTICE

If any debris falls into the hydraulic tank, the debris must be removed or machine damage will result.

NOTICE

Do not over-torque any item that threads into the hydraulic tank. This will strip the threads and require tank replacement.

This procedure assumes the Hydraulic Power Pack has been removed from the machine and is assembled except for the Motor Control Module.

See **FIG. 8** on page **25**.

1. Run a rope through the three eye-bolts and between the Motor and the Motor Control Module. Secure to a hydraulic lift.
2. Lift the Hydraulic Power Pack and place onto the electronic enclosure.
3. Align the holes with the tank then install finger-tight the four bolts and washers securing the tank to the electrical enclosure. Torque to 10 ft-lb (14 N•m).
4. Remove rope and lift.
5. Remove eye-bolts. Install original bolts (H46) into fluid housing (H03). See **FIG. 10**.
6. Perform **Install PowerHouse Pumpline** procedure, see page **24**.
7. Perform **Install Motor Control Module** procedure, see page **28**.
8. Connect heat exchanger inlet hose and fitting to elbow fitting. Connect heat exchanger outlet hose and fitting to elbow fitting located on rear right face of tank. See **Power Pack Module** on page **44**.

Replace Tank Gasket, Tank



See **FIG. 8** on page **25**.

1. Perform **Remove Hydraulic Power Pack** procedure, see page **28**.
2. Remove hex head cap screws (H22) securing hydraulic housing (H03) to tank (H20). Carefully remove motor (H01) and hydraulic housing assembly from tank.
3. Remove tank gasket. If tank is damaged, replace tank.

NOTICE

Do not over-torque any item that threads into the hydraulic tank. This will strip the threads and require tank replacement.

4. Install thrust washers (H21) onto hex head cap screws. Apply pipe sealant to threads of screws. Align tank gasket (H19), hydraulic housing, and tank (H20) then install screws. Torque to 15 ft-lb (20 N•m).
5. Perform **Install Hydraulic Power Pack** procedure, see page **29**.

Remove Motor



See **FIG. 8** on page **25**.

1. Perform **Remove Hydraulic Power Pack** procedure, see page **28**.
2. Remove four hex head cap screws (H22) securing hydraulic housing (H03) and motor (H01) to tank. Carefully remove motor and hydraulic housing assembly from tank.
3. Remove four hex head cap screws (H27) connecting mounting bracket (H26) to motor.
4. Remove four socket head cap screws (H04) securing motor to hydraulic housing. Carefully remove motor from hydraulic housing.

- Loosen set screw for motor coupler (H02) then remove motor coupler.

Install Motor



See **FIG. 8** on page **25**.

- Use four hex head cap screws (H27) and thrust washers (H21) to install Motor Control Module mounting bracket (H26) onto motor (H01).
- Install motor coupler (H02) onto motor (H01). Coupler must be 0.65-0.67 in. from the face of the motor. Torque motor coupler set screw to 15 ft-lb (20 N•m).
- Install spider coupler (H07) into motor coupler.
- Use four socket head cap screws (H04) to attach hydraulic housing (H03) to motor. Be sure to align teeth of gear coupler with the teeth of the motor coupler. Apply pipe sealant to threads of screws. Torque to 35 ft lb (47 N•m).

NOTICE

Do not over-torque any item that threads into the hydraulic tank. This will strip the threads and require tank replacement.

- Install thrust washers (H21) onto hex head cap screws (H22). Apply pipe sealant to threads of screws. Align tank gasket (H19), hydraulic housing, and tank (H20) then install screws. Torque to 15 ft-lb (20 N•m).
- Perform **Install Hydraulic Power Pack** procedure, see page **29**.

Remove Hydraulic Gear Pump



See **FIG. 8** on page **25**.

- Perform **Remove Hydraulic Power Pack** procedure, see page **28**.
- Remove hex head cap screws (H22) securing hydraulic housing (H03) to tank. Carefully remove motor (H01) and hydraulic housing assembly.
- Remove tube (H11).
- Remove elbow fittings (H10, H12) from gear pump (H05).
- Remove two hex head cap screws (H08) securing gear pump to hydraulic housing.
- Remove spider coupler (H07).
- Loosen set screw for gear coupler (H06) then remove gear coupler from gear pump.

Install Hydraulic Gear Pump



See **FIG. 8** on page **25**.

- Install gear coupler (H06) onto gear pump (H05). Coupler must be 0.12 to 0.13 in. from the face of the gear pump. Torque gear coupler set screw to 15 ft-lb (20 N•m).
- Install spider coupler (H07) into gear coupler.
- Use two hex head cap screws (H08) to attach gear pump to hydraulic housing. Be sure to align teeth of gear coupler with the teeth of the motor coupler. Torque screws to 35 ft-lb (47 N•m).
- Apply a light coat of lubricant to seals of elbow fittings (H10, H12). Install elbow fittings into gear pump. See **FIG. 8** on page **25**. for fitting alignment. Torque both fittings to 40 ft-lb (54 N•m).

- Apply a light coating of lubricant to seals of tube (H11). Install tube (H11) onto elbow fitting (H10) and straight fitting (H09). Hand-tighten then use wrench to tighten 90 degrees further.

NOTICE

Do not over-torque any item that threads into the hydraulic tank. This will strip the threads and require tank replacement.

- Install thrust washers (H21) onto hex head cap screws (H22). Apply pipe sealant to threads of screws. Align tank gasket (H19), hydraulic housing, and tank (H20) then install screws. Torque to 15 ft-lb (20 N•m).
- Perform **Install Hydraulic Power Pack** procedure, see page 29.

Replace Power Supply



- Turn off system power.
- Remove electrical enclosure door.
- Disconnect power supply (1a) wires from the filter (1c) splitter connector (1d).
- Remove nuts and washers that secure the power supply to the electrical enclosure.
- Install new power supply to electrical panel. Secure with nuts and washers.
- Connect power supply wires to the filter and the splitter connector.

- Replace electrical enclosure door and turn on system power.

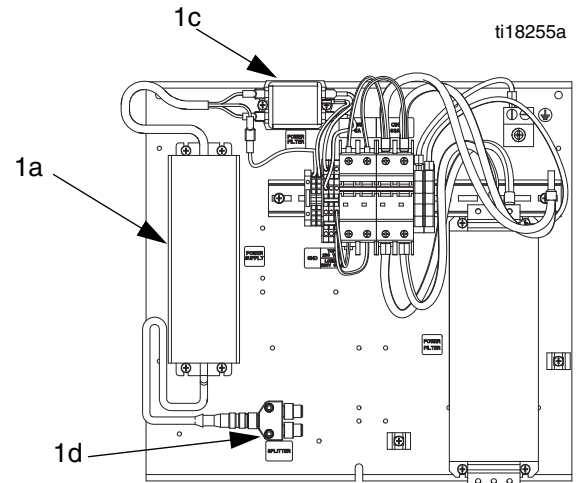

Replace Circuit Breaker



- Turn off system power.
- Remove electrical enclosure door.
- Disconnect wire harnesses from circuit breaker.
- Remove circuit breaker.
- Install new circuit breaker and connect wire harnesses.
- Replace electrical door and turn on system power.

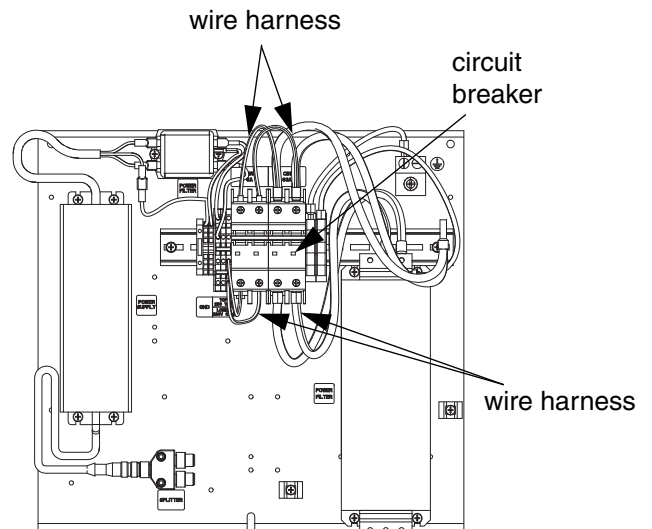

	Description		Part	Ref
HFRL01	1	1	---	001
HFRL02	1	1	24M034	002
HFRL03	1	1	24M035	
HFRL04	1	1	L020S1	003
HFRL05	1	1	L025S1	
HFRL06	1	1	L030S1	
HFRL07	1	1	L040S1	
HFRL08	1	1	L050S1	
HFRL09	1	1	L060S1	
HFRL10	1	1	L065S1	
HFRL11	1	1	L080S1	
HFRL12	1	1	L086S1	
HFRL13	1	1	L100S1	
HFRL14	1	1	L160S1	004
HFRL15	1	1	L050S1	
HFRL16	1	1	L060S1	
HFRL17	1	1	L065S1	
HFRL18	1	1	L080S1	
HFRL19	1	1	L086S1	
HFRL20	1	1	24M167	005
HFRL21	1	1	24M102	006
HFRL22	1	1	24M099	
HFRL23	1	1	24M106	007
HFRL24	1	1	255179	008
HFRL25	1	1	24E505	009
HFRL26	1	1	24E250	010
HFRL27	1	1	120955	011
HFRL28	1	1	24M129	015
HFRL29	1	1	24M154	016
HFRL30	1	1	16A093	017
			121399	018

--- Not for sale.

HFRS Models

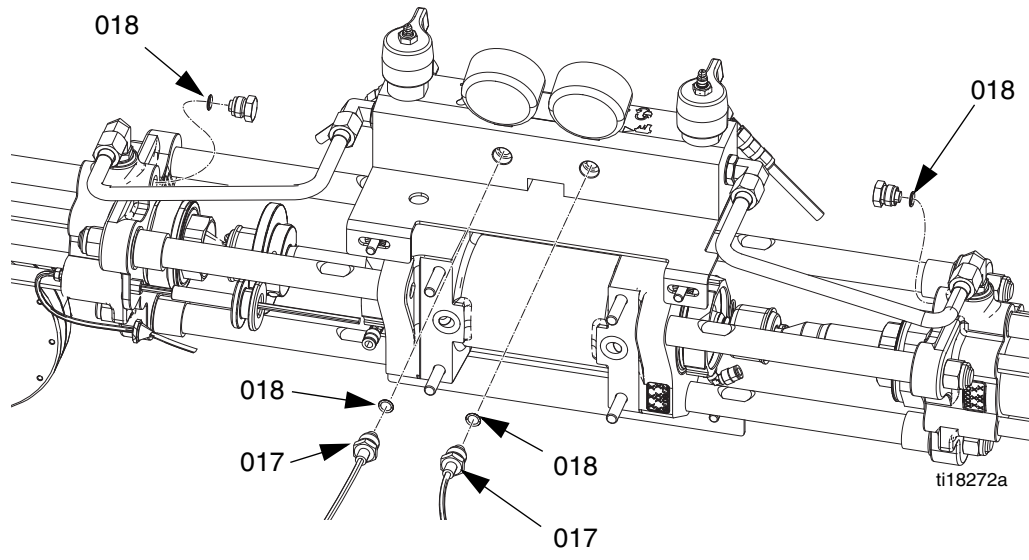
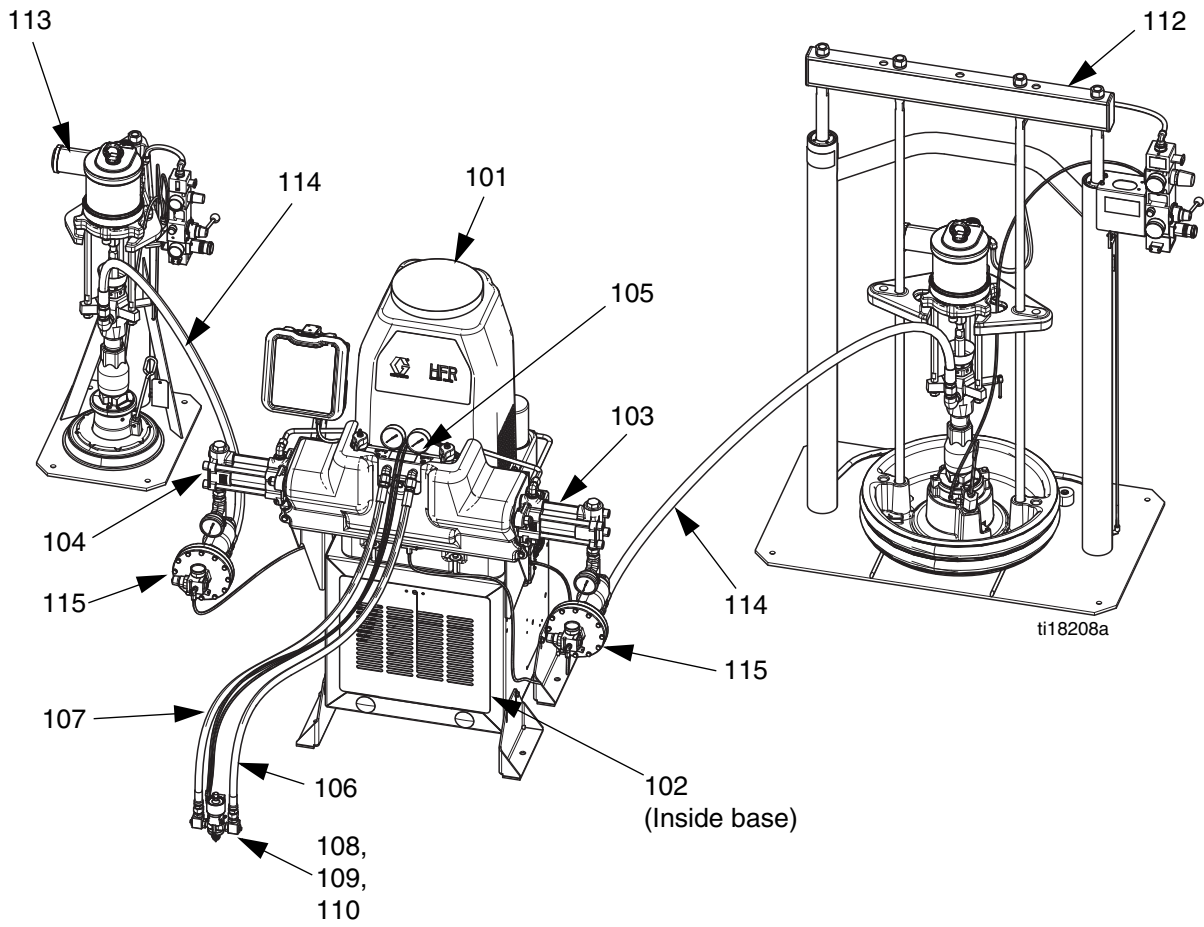

FIG. 12: HFRS Models

	Ref		Part		Description	
	101	---			MODULE, base, HFR, silicone, laminate	
	102	24M034			MODULE, power, HFR, 230v/1ph	
		24M035			MODULE, power, HFR, 400v/3ph, ce	
	103	L010S1			LOWER, chemical, 10, SST, ucup	
		L040S1			LOWER, chemical, 40, SST, ucup	
		L060S1			LOWER, chemical, 60, SST, ucup	
		L080S1			LOWER, chemical, 80, SST, ucup	
		L100S1			LOWER, chemical, 100, SST, ucup	
	104	L010S1			LOWER, chemical, 10, SST, ucup	
		L015S1			LOWER, chemical, 15, SST, ucup	
		L020S1			LOWER, chemical, 20, SST, ucup	
	105	24M167			MODULE, outlet, fluid, HFR,CS	
		24M168			MODULE, outlet, fluid, HFR, SST	
	106	24M100			KIT, hose, 1/2x10, CS, B, silicone	
		24M103			KIT, hose, 1/2x10, SS, B, silicone	
		24M105			KIT, hose, 1/2x10, CS, A, silicone	
		24M108			KIT, hose, 1/2x10, SS, A, silicone	
	107	24M107			KIT, hose, 1/4x10, CS, A, silicone	
		24M109			KIT, hose, 1/4x10, SS, A, silicone	
		24M110			KIT, hose, 3/16x10, SS, A, silicone	
	108	255179			VALVE, dispense, 1:1, soft seats	
	109	24E505			KIT, orifice block	
	110	24E250			KIT, orifices, 1/4"	
	111	120955			CORD SET, euro, male, 4pin, 3wire, 4 meter	
	112 & 113	CM7A59			SUPPLY UNIT, 20:1, 0 volt, d200, 200l, CS	
		CM7C58			SUPPLY UNIT, 20:1, 0 volt, d200, 200l, SS	
		CM7A3C			SUPPLY UNIT, 20:1, 0 volt, s20, 20l, CS	
		CM7C3F			SUPPLY UNIT, 20:1, 0 volt, s20, 20l, SS	
	114	24M181			KIT, hose, 3/4x15, inlet, CS	
		24M182			KIT, hose, 3/4x15, inlet, SS	
	115	24M132			KIT, assy, inlet, regulator, CS	
		24M133			KIT, assy, inlet, regulator, SS	
	117	16A093			SENSOR, pressure, fluid outlet	
	118	121399			PACKING, o-ring 012 fx75	
HFRS01	1	1	2			
HFRS02	1	1	2			
HFRS03	1	1	2			
HFRS04	1	1	2			
HFRS05	1	1	2			
HFRS06	1	1	2			
HFRS07	1	1	2			
HFRS08	1	1	2			
HFRS09	1	1	1			
HFRS10	1	1	1			
HFRS11	1	1	1			
HFRS12	1	1	1			
HFRS13	1	1	1			
HFRS14	1	1	1			
HFRS15	1	1	1			
HFRS16	1	1	1			
HFRS17	1	1	1			
HFRS18	1	1	1			
HFRS19	1	1	1			
HFRS20	1	1	1			
HFRS21	1	1	1			
HFRS22	1	1	1			
HFRS23	1	1	1			
HFRS24	1	1	1			
HFRS25	1	1	1			
HFRS26	1	1	1			
HFRS27	1	1	1			
HFRS28	1	1	1			
HFRS29	1	1	1			
HFRS30	1	1	1			
HFRS31	1	1	1			
HFRS32	1	1	1			

	Description		Part	Ref
HFRS65	1	1	---	101
HFRS66	1	1	24M034	102
HFRS67	1	1	24M035	103
HFRS68	1	1	L010S1	104
HFRS69	1	1	L040S1	105
HFRS70	1	1	L060S1	106
HFRS71	1	1	L080S1	107
HFRS72	1	1	L100S1	108
HFRS73	1	1	L010S1	109
HFRS74	1	1	L015S1	110
HFRS75	1	1	L020S1	111
HFRS76	1	1	24M167	112
HFRS77	1	1	24M168	113
HFRS78	1	1	24M100	114
HFRS79	1	1	24M103	115
HFRS80	1	1	24M105	117
HFRS81	1	1	24M108	118
HFRS82	1	1	24M107	
HFRS83	1	1	24M109	
HFRS84	1	1	24M110	
HFRS85	1	1	255179	
HFRS86	1	1	24E505	
HFRS87	1	1	24E250	
HFRS88	1	1	120955	
HFRS89	1	1	CM7A59	
HFRS90	1	1	CM7C58	
HFRS91	1	1	CM7A3C	
HFRS92	1	1	CM7C3F	
HFRS93	1	1	24M181	
HFRS94	1	1	24M182	
HFRS95	1	1	24M132	
HFRS96	1	1	24M133	
			16A093	
			121399	

		Description	Part	Ref
HFRS97	1	MODULE, base, HFR, silicone, laminate	---	101
HFRS98	1	MODULE, power, HFR, 230v/1ph	24M034	102
HFRS99	1	MODULE, power, HFR, 400v/3ph, ce	24M035	
HFRSA0	1	LOWER, chemical, 10, SST, ucup	L010S1	103
HFRSA1	1	LOWER, chemical, 40, SST, ucup	L040S1	
HFRSA2	1	LOWER, chemical, 60, SST, ucup	L060S1	
HFRSA3	1	LOWER, chemical, 80, SST, ucup	L080S1	
HFRSA4	1	LOWER, chemical, 100, SST, ucup	L100S1	
		LOWER, chemical, 10, SST, ucup	L010S1	
		LOWER, chemical, 15, SST, ucup	L015S1	
		LOWER, chemical, 20, SST, ucup	L020S1	
		MODULE, outlet, fluid, HFR,CS	24M167	105
		MODULE, outlet, fluid, HFR, SST	24M168	
		KIT, hose, 1/2x10, CS, B, silicone	24M100	106
		KIT, hose, 1/2x10, SS, B, silicone	24M103	
		KIT, hose, 1/2x10, CS, A, silicone	24M105	107
		KIT, hose, 1/2x10, SS, A, silicone	24M108	
		KIT, hose, 1/4x10, CS, A, silicone	24M107	
		KIT, hose, 1/4x10, SS, A, silicone	24M109	
		KIT, hose, 3/16x10, SS, A, silicone	24M110	
		VALVE, dispense, 1:1, soft seats	255179	
		KIT, orifice block	24E505	
		KIT, orifices, 1/4"	24E250	110
		CORD SET, euro, male, 4pin, 3wire, 4 meter	120955	111
		SUPPLY UNIT, 20:1, 0 volt, d200, 200l, CS	CM7A59	112 & 113
		SUPPLY UNIT, 20:1, 0 volt, d200, 200l, SS	CM7C58	
		SUPPLY UNIT, 20:1, 0 volt, s20, 20l, CS	CM7A3C	
		SUPPLY UNIT, 20:1, 0 volt, s20, 20l, SS	CM7C3F	
		KIT, hose, 3/4x15, inlet, CS	24M181	114
		KIT, hose, 3/4x15, inlet, SS	24M182	
		KIT, assy, inlet, regulator, CS	24M132	115
		KIT, assy, inlet, regulator, SS	24M133	
		SENSOR, pressure, fluid outlet	16A093	117
		PACKING, o-ring 012 fx75	121399	118

--- Not for sale.

Base Module

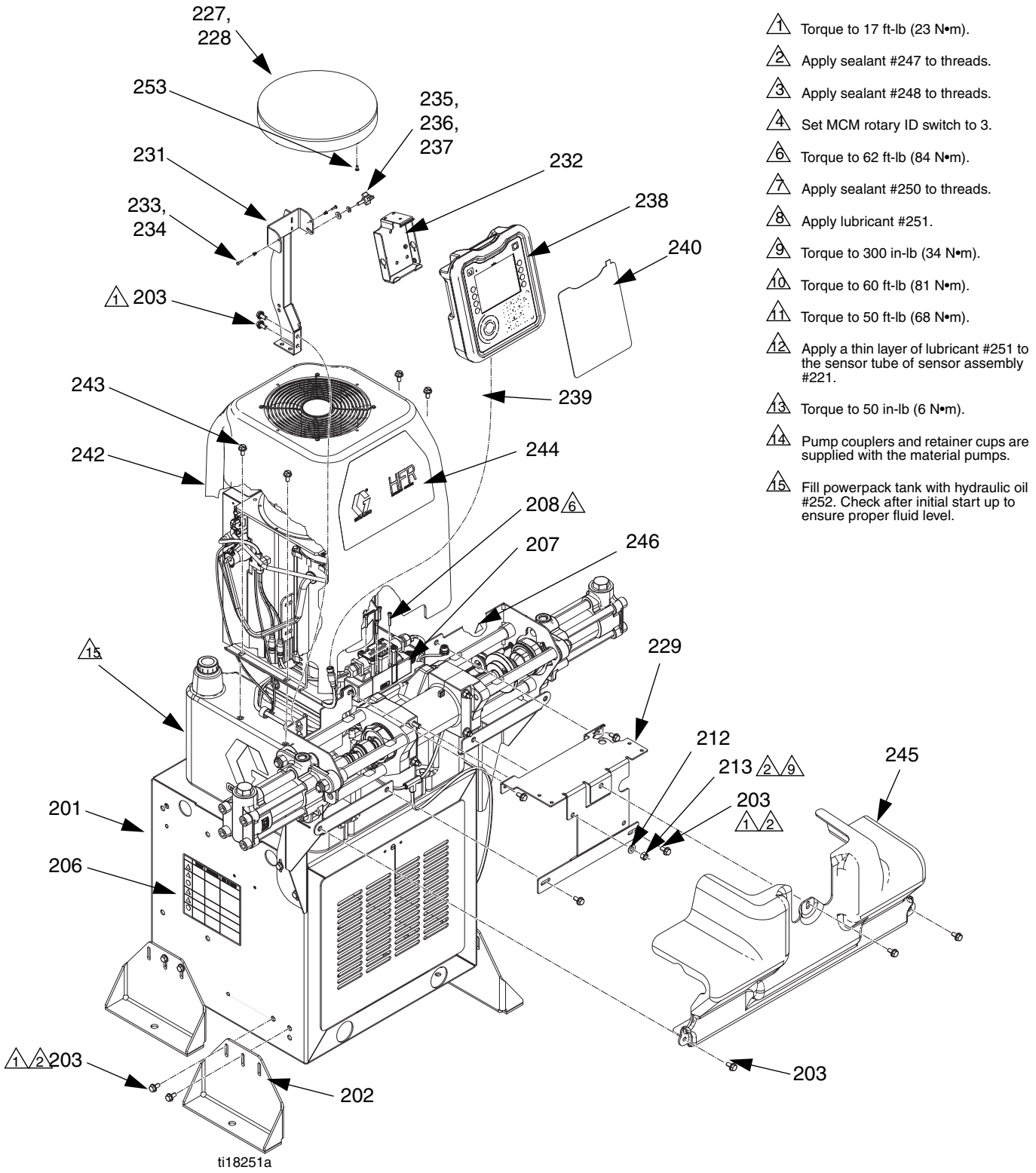

FIG. 13: Base Module, Image 1 of 2

Parts

Ref	Part	Description	Qty
201	---	MODULE, powerpack, enclosure, no cooler	1
202	24M024	BRACKET, anchor, cube, CS, painted	4
203	111800	SCREW, cap, hex head	23
204	122970	FITTING, adapter, jic(08)xsaе(08)	1
205	123140	FITTING, cap, 1/2 jic, CS	1
206 ▲	15M511	LABEL, warning, eng/span/fre	1
207	123313	VALVE, directional, hydraulic	1
208	123366	SCREW, SHC, 10-24x1.125, s	4
209	16E281	STUD, threaded, 3/8-16 x 6.0	4
210	258771	DRIVER, hydraulic, horizontal, 3.0"stroke	1
211	103413	PACKING, o-ring	2
212	100731	WASHER	4
213	U90126	NUT, hex, 3/8-16, MS	4
214	15X519	ROD, tie, 12 long, 5/8-11 UNC	6
215	123112	FITTING, tee, 1/4 tube, pre-stolock, brass	1
216	054175	TUBE, nylon, rd	5
217	24E168	BRACKET, pump, right, HFR, painted	1
218	24E169	BRACKET, pump, left, HFR, painted	1
219	16E277	BUSHING, flanged, nylon, 1.0x1.25x1.0	4
220	101712	NUT, lock	6
221	258669	SENSOR, assembly	1
222	258704	SPOOL, assembly	1
223	16A509	COLLAR, sensor	1
224	119999	BOLT, shoulder	2
225	125966	CLIP, hairpin, 3/4	1
226	123798	CABLE, m8, 4-pin, malexfemale, 1m, molded	1
227	16G251	HOUSING, filter, painted	1
228	16G252	FILTER, air	1
229	24E170	BRACKET, manifold, HFR, painted	1
230	121581	HARNESS, i/o, m12 x m12	1
231	24E647	BRACKET, ADM mounting, painted	1
232	255235	BRACKET, mounting, assembly	1
233	120060	CLIP, speed, tubular	2
234	122168	RIVET, aluminum	2
235	110755	WASHER, plain	1
236	100016	WASHER, lock	1
237	121253	KNOB, display adj., ram pkgs	1
238	24E451	MODULE, GCA, ADM	1
239	121002	CABLE, CAN, female / female 1.5m	1
240	15V551	SHIELD, membrane, ADM	1
241	24C757	KIT, MD2, solenoid, machine mount	1

Ref	Part	Description	Qty
242	24B855	COVER, assembly	1
243	124804	SCREW, hex, slotted	4
244 ▲	16C744	LABEL, HFR metering system	1
245	24C234	COVER, shroud, front, fixed ratio	1
246 ▲	15H108	LABEL, pinch point	1
247	---	SEALANT, anaerobic	1
248	---	SEALANT, pipe, SST	1
249	16H821	TOKEN, GCA, upgrade, GMS™, HFR	1
250	---	ADHESIVE, anaerobic, loctite 2760	1
251	---	LUBRICANT, grease	1
252	---	FLUID, hydraulic	9
253	15U075	SCREW, cap, bh, 8-32 x .37	4
254	C20365	FITTING, tee, air, QD	1
255	125424	FITTING, plug, tube, push, 1/4	2

▲ Replacement Danger and Warning labels, tags, and cards are available at no cost.

--- Not for sale.

Power Pack Module

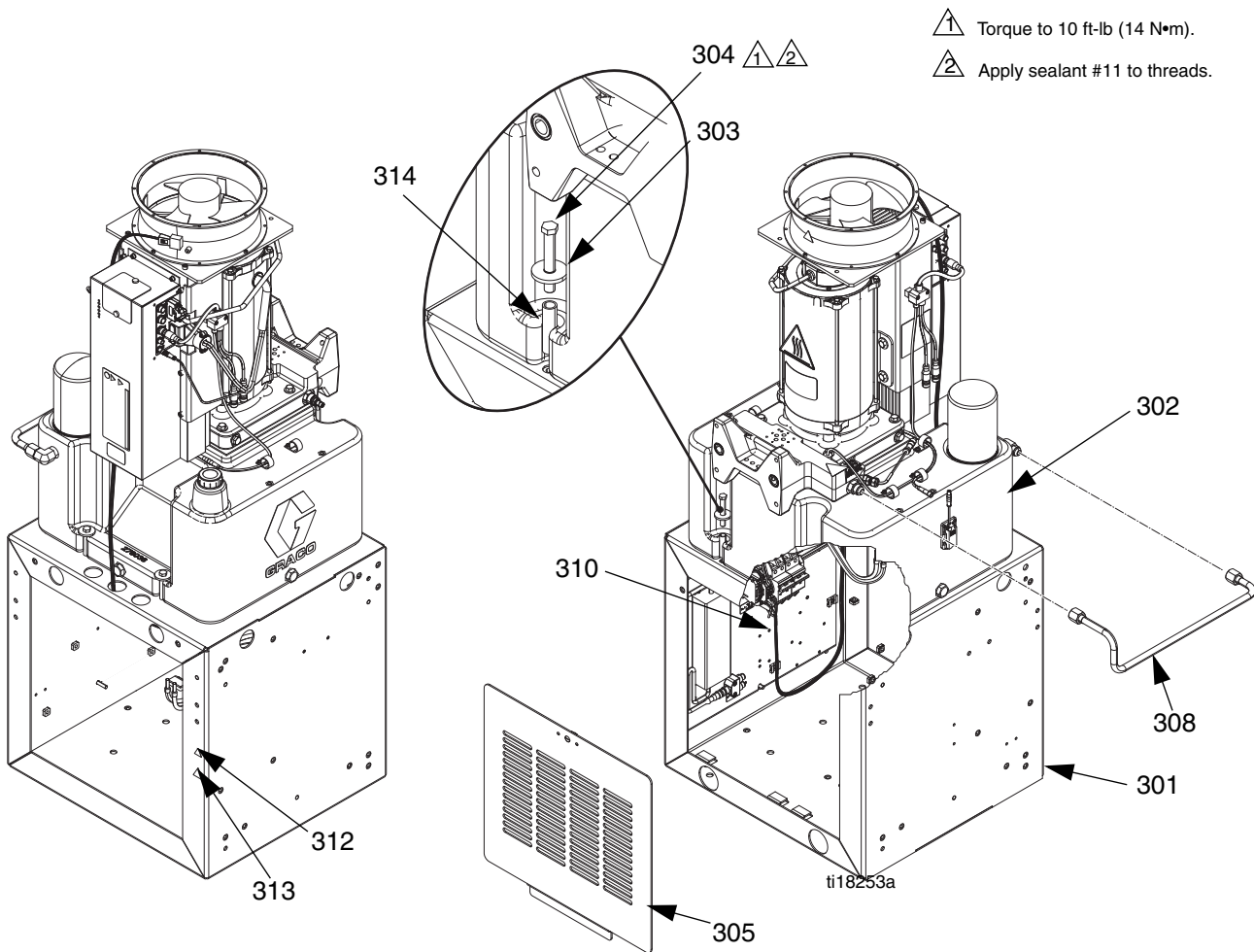

FIG. 15: Power Pack Module

Ref	Part	Description	Qty
301	---	ENCLOSURE, frame, painted	1
302	---	MODULE, hydraulic, DC, powerpack	1
303	U90205	WASHER, flat, 3/8, .41x1.25x.13, MS	4
304	802277	SCREW, machine	4
305	257933	COVER, enclosure, slotted, assembly	1
308	16M464	TUBE, 1/2 od, SST, manifold to tank	1
310	24C518	CORD, fan, heat exchanger, MCM	1
311	---	SEALANT, anaerobic	1
312 ▲	189930	LABEL, caution	1
313 ▲	15H108	LABEL, pinch point	1
314	16G014	BUSHING	4

▲ Replacement Danger and Warning labels, tags, and cards are available at no cost.

--- Not for sale.

Hydraulic DC Power Pack Module, 257442

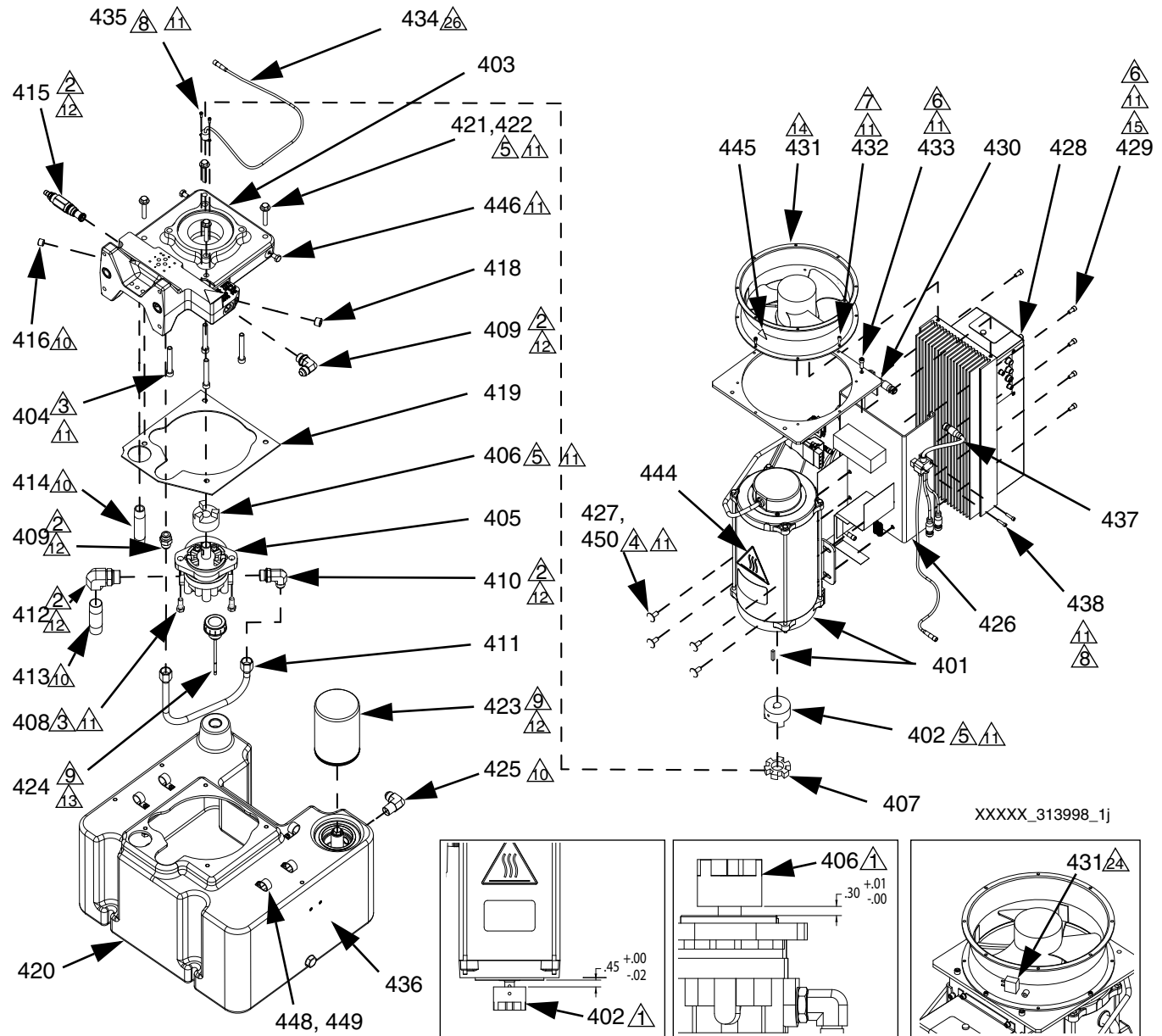

XXXXX_313998_1j

- | | | |
|---|--|---|
| <ul style="list-style-type: none"> △1 Assemble coupler to specified dimensions prior to mounting assembly to housing. △2 Torque to 40 ft-lb (54 N•m). △3 Torque to 35 ft-lb (47 N•m). △4 Torque to 20 ft-lb (27 N•m). △5 Torque to 15 ft-lb (20 N•m). △6 Torque to 10 ft-lb (14 N•m). △7 Torque to 58 in-lb (6.5 N•m). | <ul style="list-style-type: none"> △8 Torque to 34 in-lb (3.8 N•m). △9 Torque 1/4 turn past hand-tight. △10 Apply PTFE tape on installation end only. △11 Apply medium strength thread locker before assembly. △12 Apply light coating of lubricant to seals. △13 Fill reservoir with hydraulic fluid. | <ul style="list-style-type: none"> △14 Orient with airflow arrow pointing toward mounting bracket. △15 Prior to installing Ref. 728 into Ref. 726, install Ref. 729 into Ref. 728 and adjust head 1/8 in. from surface. △24 Align fan plug as shown. △26 Apply thermal lubricant to contact side. |
|---|--|---|

Fig. 16: Hydraulic DC Power Pack Module

Ref	Part	Description	Qty
401	24C719	MOTOR, power connector, assembly	1
402	16A951	COUPLER, motor	1
403	15W772	HOUSING, machined.hydraulic, module	1
404	123338	SCREW, shc, 3/8-16x2.75, s	4
405	122295	PUMP, gear, hydraulic, h39	1
406	16A952	COUPLER, pump	1
407	16A953	COUPLER, spider	1
408	123942	FASTENER, screw, cap, hex head	2
409	121309	FITTING, adapter, sae-orb x jic	2
410	122520	FITTING, elbow, male, sae x jic	1
411	15W798	TUBE, pump to tube outlet	1
412	122606	FITTING, elbow, male, female	1
413	115597	NIPPLE	1
414	101353	FITTING, nipple, pipe	1
415	124274	VALVE, relief, fast acting	1
416	100721	PLUG, pipe	1
418	101754	PLUG, pipe	1
419	15X622	GASKET, housing, to, tank	1
420	---	RESERVOIR, assembly, 8 gallon	1
421	101971	WASHER, thrust	4
422	111302	SCREW, cap, hex hd	4
423	15J937	FILTER, oil, 18-23 psi bypass	1
424	116915	CAP, breather filler	1
425	121486	FITTING, elbow, male, 1/2jicx1/2npt	1
426	15Y912	BRACKET, MCM mounting	1
427	100057	SCREW, cap, hex hd	4
428	257396	MODULE, GCA, MCM	1
429	101550	SCREW, cap	7
430	---	PLATE, mounting, fan	1
431	122301	FAN, 220v	1
432	112310	SCREW, cap	4
433	100644	SCREW, cap	2
434	123367	HARNESS, m8 x thermal switch, 4-pin	1
435	102410	SCREW, cap socket head	2
437	123303	HARNESS, m12	2
438	295709	SCREW, cap, sockethead	4
439	---	LUBRICANT, grease	1
440	---	SEALANT, anaerobic	1
441	---	SEALANT, pipe, SST	1
443 ▲	189285	LABEL, caution	1
444 ▲	121208	LABEL, hot surface, 3.8x3.29 triangle	1
445 ▲	15H108	LABEL, pinch point	1
446	113802	SCREW, hex hd, flanged	2
447	---	LUBRICANT, thermal	1
448	123601	CLAMP, wire, harness, nylon, 3/4"	5
449	103833	SCREW, mach	5
450	100023	WASHER, flat	4
451	---	LUBRICANT, anti-seize	1

▲ Replacement Danger and Warning labels, tags, and cards are available at no cost.

--- Not for sale.

Power Modules, 24M034 & 24M035

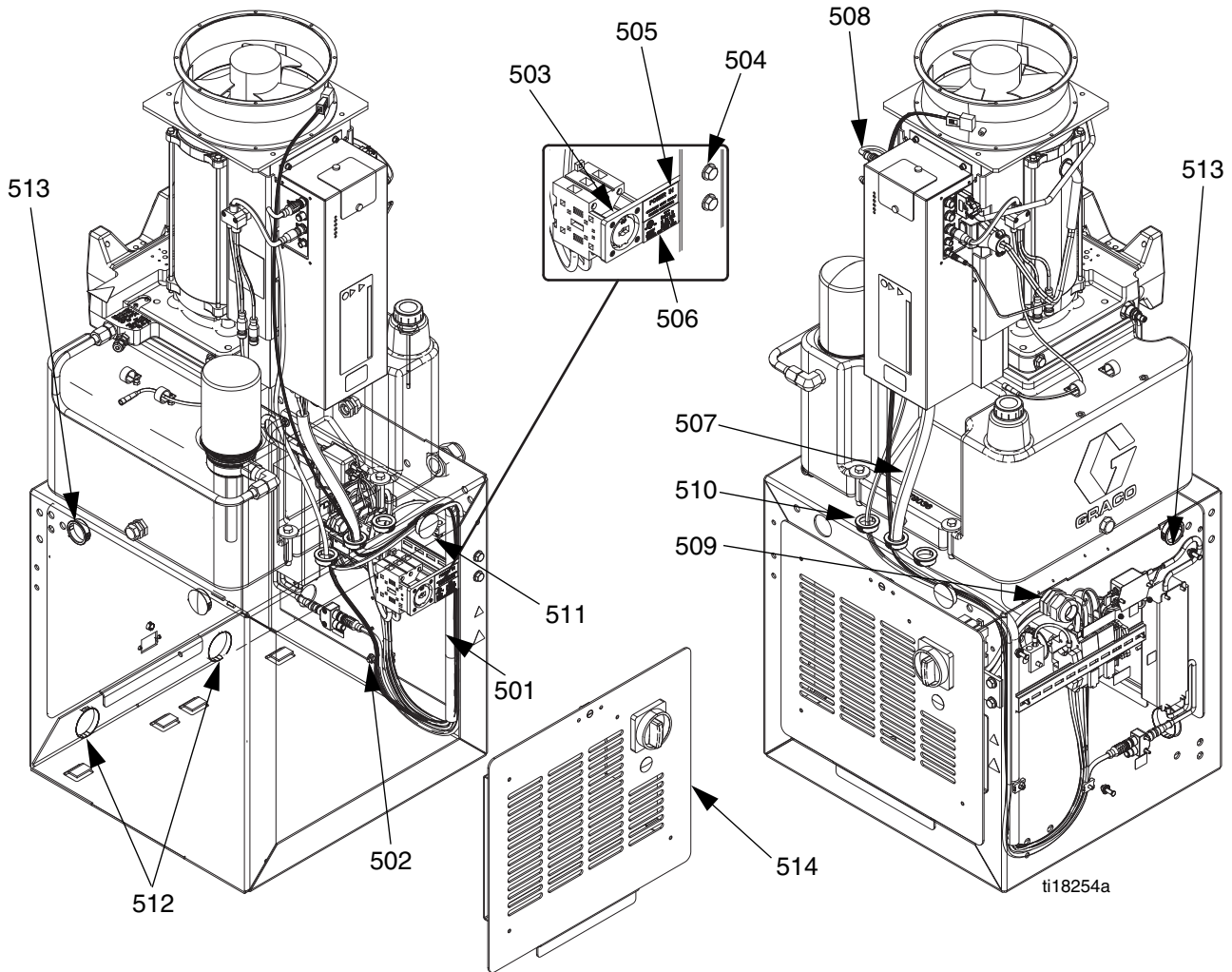

FIG. 17: Power Modules

Ref	Part	Description	Qty	
			24M034, MODULE, power, HFR, 230V/1PH	24M035, MODULE, power, HFR, 400V/3PH
501	24M030	PANEL, power, HFR, 230v	1	
	24M031	PANEL, power, HFR, 400v		1
502	115942	NUT, hex, flange head	3	3
503	24M032	SWITCH, assy, disc, HFR, 230v	1	
	24M033	SWITCH, assy, disc, HFR, 400v		1
504	111800	SCREW, cap, hex head	2	2
505	16K918	LABEL, power in, branch circuit	1	1
506	---	LABEL, ETL, UL, 508a	1	1
507	24M046	HARNESS, wire, MCM, 6/3, HFR	1	1
508	121003	CABLE, can, female / female 3.0m	1	1
509	121160	GRIP, cord, .71-1.02	1	1
510	123679	BUSHING, wire protector, 1 3/8 OD	3	3
511	123398	PLUG, hole, 1.5"dia	4	4
512	123590	PLUG, hole, 2" dia	2	2
513	123589	BUSHING, wire protector, snap-in	2	2
514	24M029	COVER, enclosure, disconnect, HFR	1	1

--- Not for sale.

Power Panels, 24M030 & 24M031

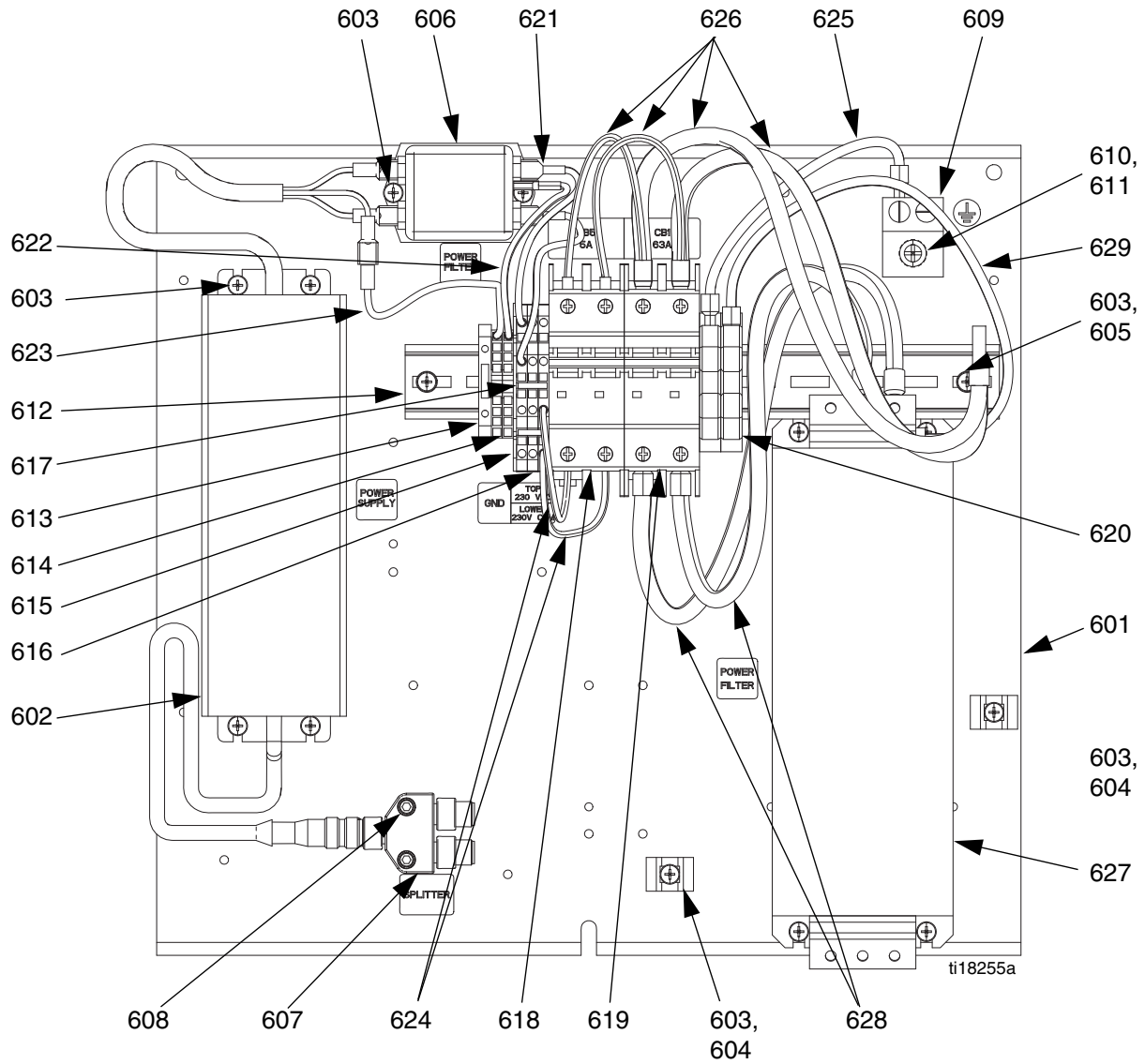

FIG. 18: Power Panels

Ref	Part	Description	Qty	
			24M030, PANEL, power, HFR, 230V	24M031, PANEL, power, HFR, 400V
601	---	PANEL, electric, heat	1	1
602	24D207	POWER SUPPLY, 24VDC, 4A, 100W, 230VAC	1	1
603	103833	SCREW, mach	10	14
604	123452	HOLDER, anchor, wire tie, nylon	2	2
605	116876	WASHER, flat	2	2
606	123718	FILTER, emi, 6a, spade connector	1	1
607	121807	CONNECTOR, splitter	1	1
608	106246	SCREW, cap	2	2
609	117666	TERMINAL, ground	1	1
610	100985	WASHER, lock external	1	1
611	113783	SCREW, machine, pn head	1	1
612	---	RAIL, mounting, din, 35mm, 12"	1	1
613	123384	BLOCK, end stop, terminal	1	1
614	123686	BLOCK, terminal, ground, 35mm	2	2
615	123847	BARRIER, end plate, term	1	1
616	123387	BLOCK, terminal, 2circuit	3	3
617	---	TERMINAL, jumper, 3 pin	2	2
618	123296	CIRCUIT, breaker, 2 pole, 5 amp, ul489	1	1
619	123668	CIRCUIT, breaker, 2 pole, 63 amp, ul489	1	1
620	123363	BLOCK, terminal, ground, 10mm	2	2
621	24D358	HARNESS, filter/terminal	2	2
622	24D359	HARNESS, filter/terminal, ground	1	1
623	24D426	HARNESS, wire, 18awg, terminal/ferrule, ground	1	1
624	24C377	HARNESS, wire, terminal, 4"	2	2
625	16A649	HARNESS, ground wire, 8 awg	1	1
626	16A650	HARNESS, wire, 6 awg, 14 awg	2	2
627	123785	FILTER, emi, 55a, 3 phase		1
628	16D536	HARNESS, wire, 6 awg, ferruled, 23 in		1
629	24D216	HARNESS, wire, 8awg, ground		1

▲ Replacement Danger and Warning labels, tags, and cards are available at no cost.

--- Not for sale.

Fluid Outlet Modules, 24M167 & 24M168

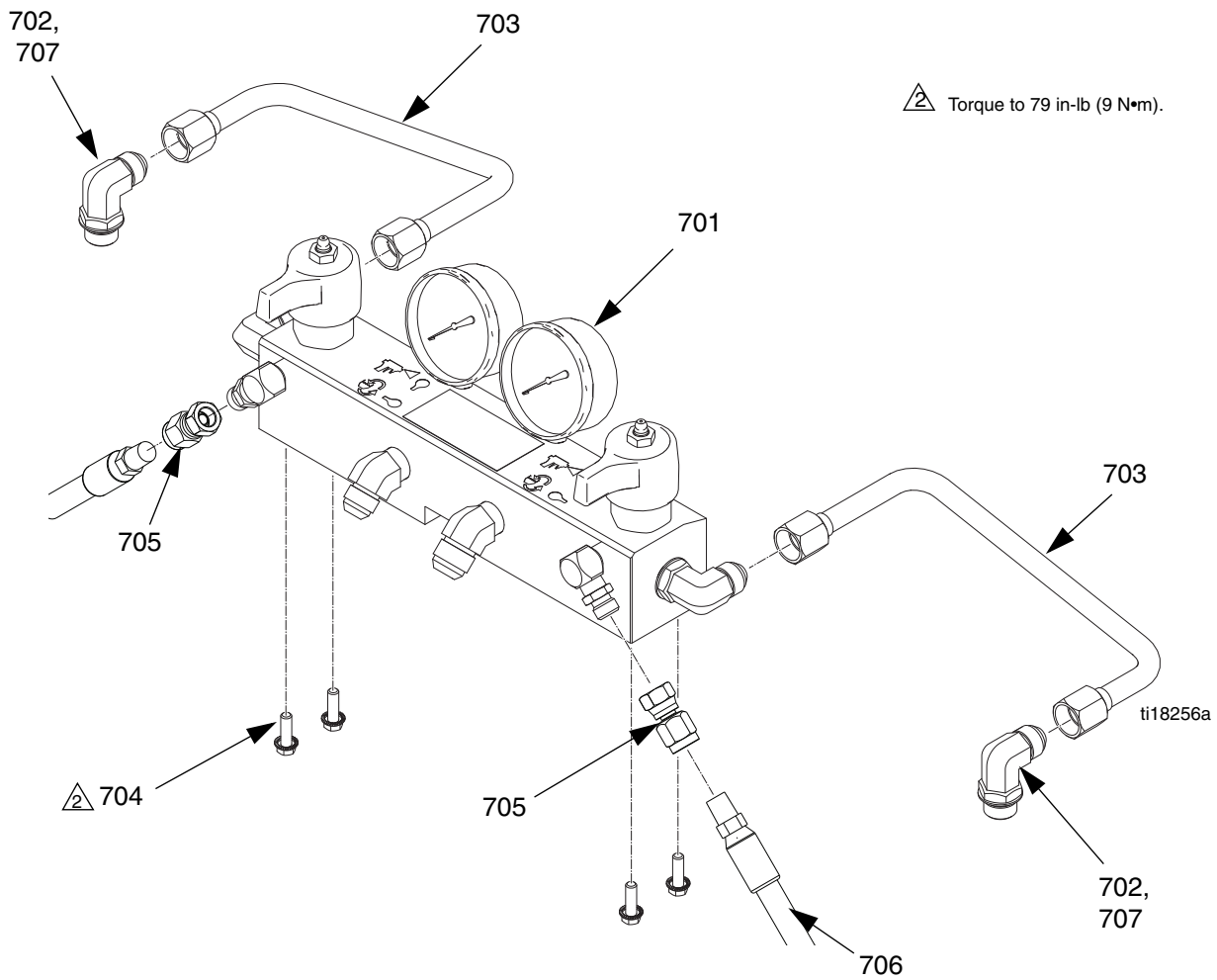

FIG. 19: Fluid Outlet Modules

Ref	Part	Description	Qty	
			24M167, MODULE, outlet, fluid, HFR, CS	24M168, MODULE, outlet, fluid, HFR, SST
701	289999	MANIFOLD, fluid, SST, HFR		1
	255629	MANIFOLD, inlet, fluid, h-controller	1	
702	123108	FITTING, elbow, 3/4sae x 1/2jic, sst		2
	121312	FITTING, elbow, sae x jic	2	
703	16A108	TUBE, fluid, no heater	2	2
704	113796	SCREW, flanged, hex head	4	4
705	155570	SWIVEL,union	2	2
706	109150	HOSE, coupled, 6 ft	2	2
707	---	LUBRICANT, grease	1	1

--- Not for sale.

Fluid Manifolds, 255629 & 289999

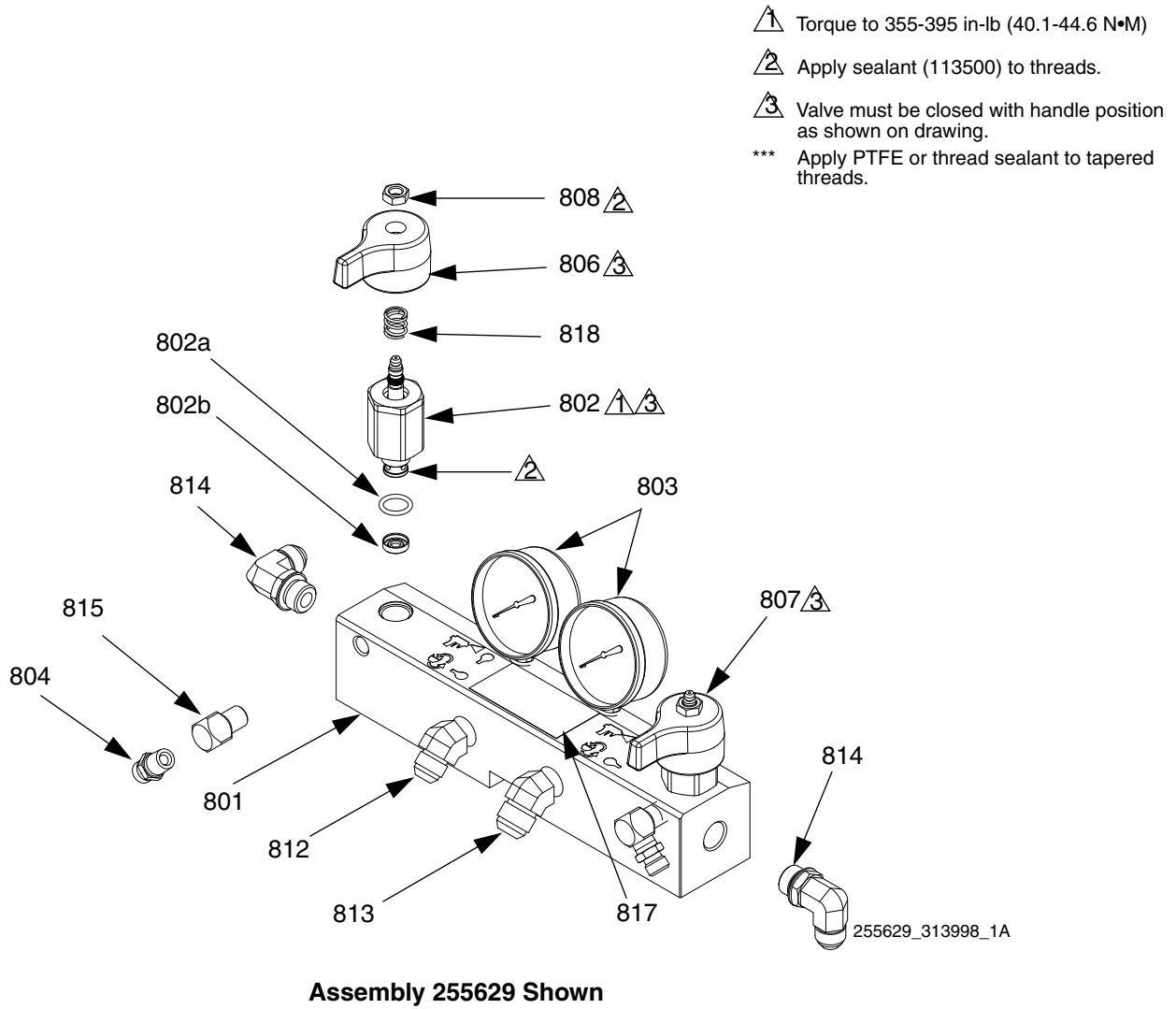

FIG. 20: Fluid Manifolds

Ref	Part	Description	Qty	
			255629, MANIFOLD, inlet, fluid, h-controller	289999, MANIFOLD, fluid, sst
801	247837	MANIFOLD, fluid, inlet, etched	1	
	24E307	MANIFOLD, machined, fluid, sst		1
802 †	247824	VALVE, drain valve	2	
	24E306	VALVE, drain, cartridge, sst		2
802a †	158674	. O-RING	1	1
802b †	247779	. SEAL, seat, valve	1	1
803	112941	GAUGE, pressure, fluid		2
	102814	GAUGE, pressure, fluid	2	
804	162453	FITTING, (1/4 npsm x 1/4 npt)	2	
	166846	FITTING, (1/4 npsm x 1/4 npt), sst		2
806	247788	HANDLE, red	1	1
807	247789	HANDLE, blue	1	1
808 †	112309	NUT, hex, jam	2	2
812	123106	FITTING, 45 elbow, #8 jic x 1/2, sst		1
	117556	FITTING, nipple, #8 jic x 1/2 npt	1	
813	123107	FITTING, elbow, #10jic x 1/2npt, sst		1
	117557	FITTING, nipple, #10 jic x 1/2 npt	1	
814	123108	FITTING, elbow, 3/4sae x 1/2jic, sst		2
	121312	FITTING, elbow, sae x jic	2	
815	100840	FITTING, elbow, street	2	
	166866	FITTING, elbow, street, sst		2
817 ▲	189285	LABEL, caution	1	1
818 †	150829	SPRING, compression	2	2

▲ Replacement Danger and Warning labels, tags, and cards are available at no cost.

† Included in the following complete valve kits*:

Assembly 255629

A (Red) Valve Kit (left/red handle) 255149.

B (Blue) Valve Kit (right/blue handle) 255150.

Valve Set Kit (both handles and grease gun) 255148.

Assembly 289999

A (Red) Valve Kit (left/red handle) 24E309.

B (Blue) Valve Kit (right/blue handle) 24E310.

Valve Set Kit (both handles and grease gun)
24E308.

* Complete valve kits also include thread sealant (Purchase kits separately).

Fluid Inlet Assembly, 24M129 (HFRL)

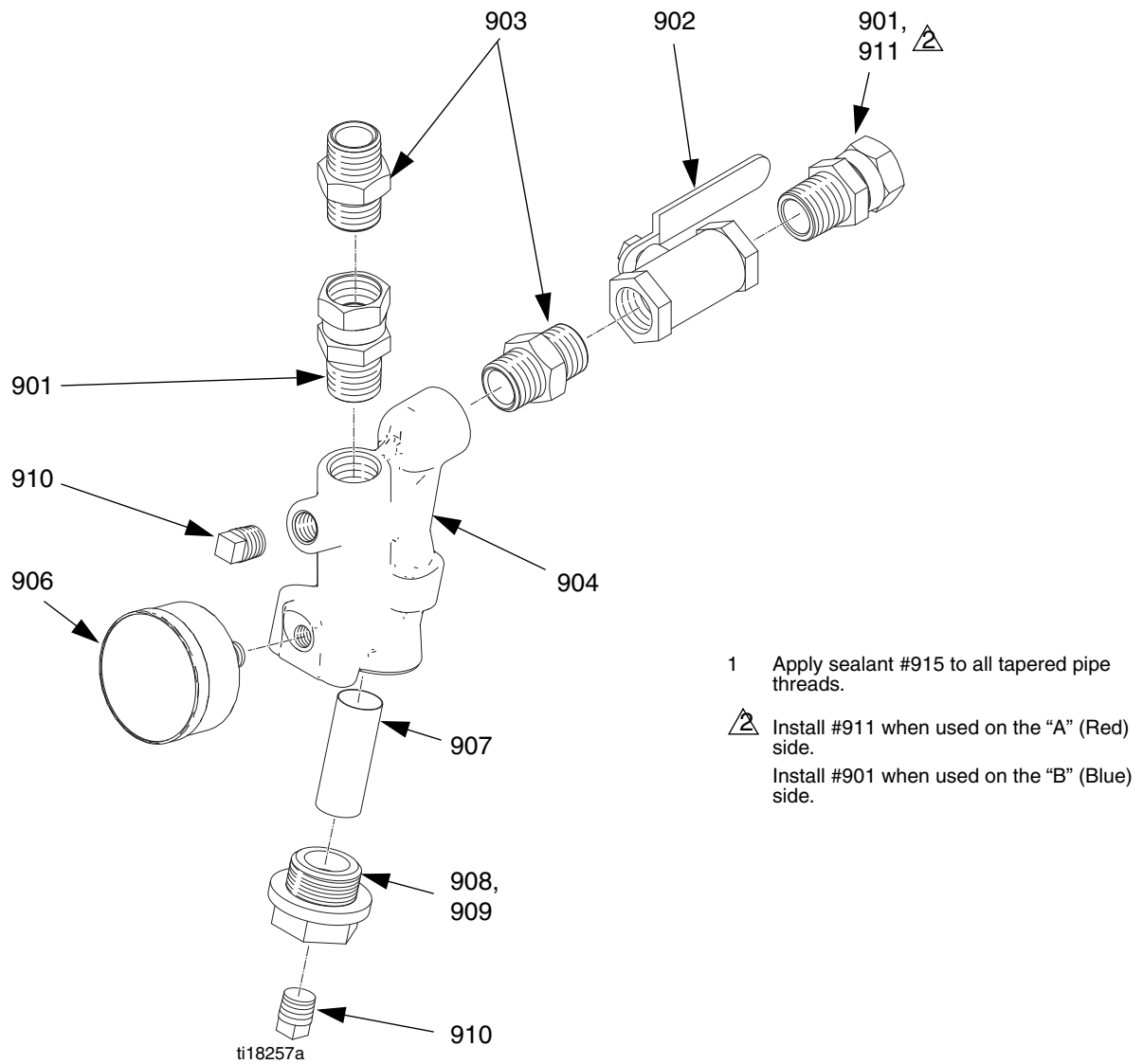



FIG. 21: Fluid Inlet Assembly (HFRL)

Ref	Part	Description	Qty
901	118459	FITTING, union, swivel, 3/4"	2
902	512151	VALVE, ball	1
903	C20487	FITTING, nipple, hex	2
904	15J119	MANIFOLD, strainer, wye, inlet	1
906	120300	GAUGE, pressure, fluid, (waterborne)	1
907	180199	FILTER, replacement	1
908	15H200	GASKET, strainer, wye, inlet	1
909	15H199	PLUG, strainer, wye, inlet	1
910	104813	PLUG, pipe	2
911	296178	FITTING, union(sw), 3/4npt x 1/2npt	1
915	---	SEALANT, pipe, sst	1

--- Not for sale.

Fluid Inlet Assemblies, 24M132 & 24M133 (HFRS)

- 1 Apply sealant #1008 to all non swiveling threads.

 Remove high pressure regulator and gauge. Replace with low pressure regulator and gauge items #1010 and #1011.

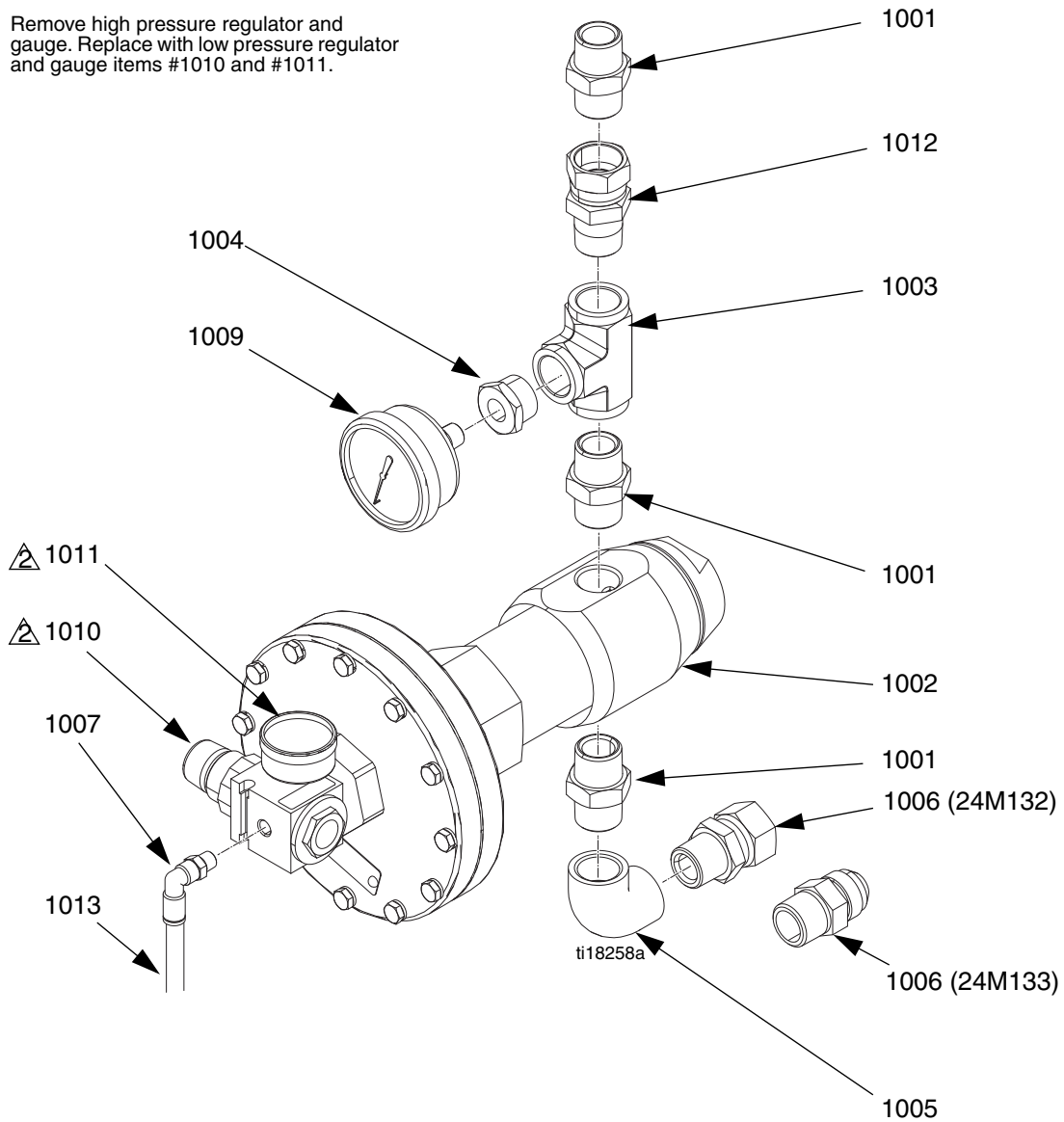

FIG. 22: Fluid Inlet Assemblies HFRS

Ref	Part	Description	Qty	
			24M132, KIT, assy, inlet, regulator, CS	24M133, KIT, assy, inlet, regulator, SST
1001	C20487	FITTING, nipple, hex	3	
	123111	FITTING, nipple, hex, 3/4npt, 3k, ss		3
1002	961635	REGULATOR, mastic, 5000 psi	1	
	C58318	REGULATOR, stainless steel		1
1003	801787	FITTING, tee, pipe 3/4	1	
	113833	TEE, pipe, female		1
1004	C19681	BUSHING, pipe	1	
	15M861	FITTING, reducer, pipe, 3/4x1/4 sst		1
1005	122764	FITTING, elbow, 3/4npt, female, 90 degree		1
	112040	FITTING, elbow, 90 degree	1	
1006	6303-21	ADAPTER, swivel, jic12x3/4npt, female/male	1	
	15M863	FITTING, connector, male		1
1007	112781	ELBOW, swivel, 90 degree	1	1
1008	---	SEALANT, pipe, sst	1	1
1009	113641	GAUGE, pressure, fluid, sst	1	1
1010	16C406	REGULATOR, air, 1/8npt, 3-30psig, 10scf	1	1
1011	119428	GAUGE, air, 30psi	1	1
1012	118459	FITTING, union, swivel, 3/4"	1	
	112268	SWIVEL, union		1
1013	---	TUBE, plyeth .250 od	4	4

--- Not for sale.

Dispense Hose Assembly Kits

24M099 Shown (Typical For Most Hose Assemblies)

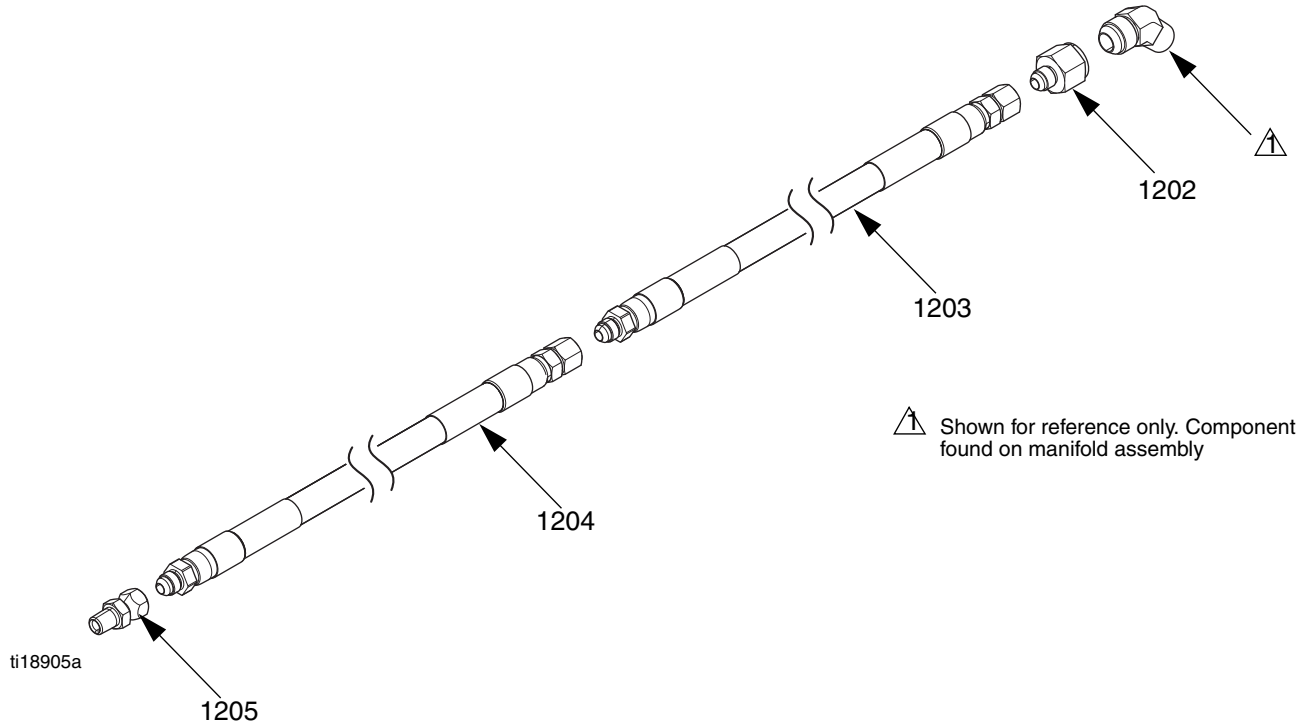

24M110 Assembly Only

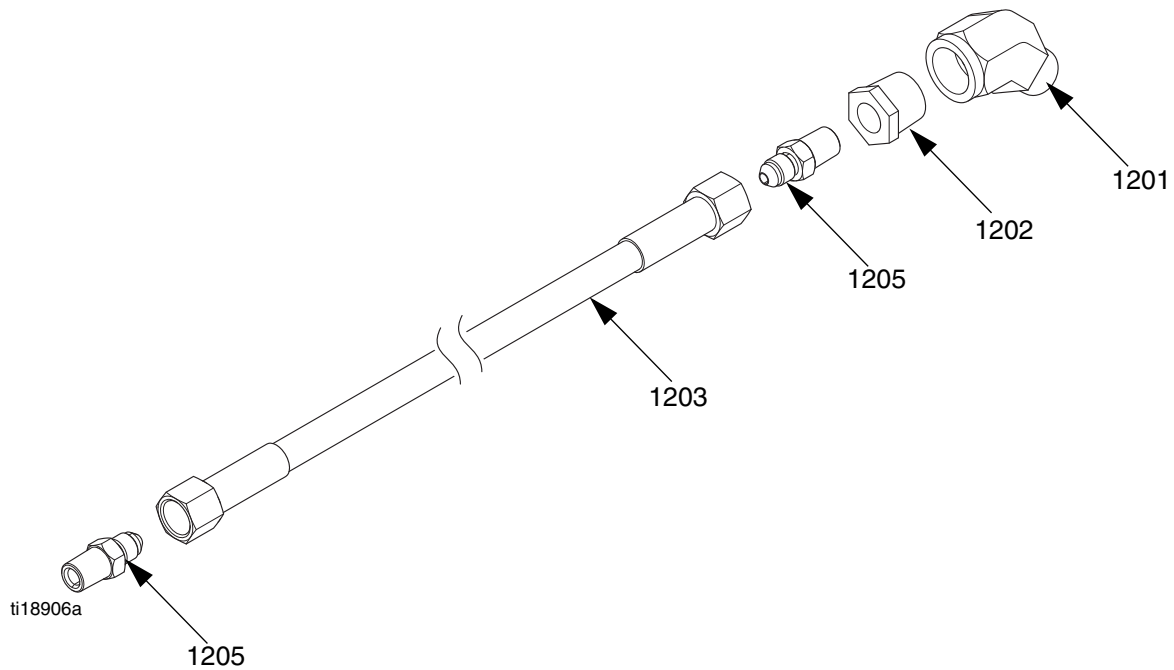

FIG. 23: Dispense Hose Assembly Kits

B (Blue) Side Hoses								
Ref	Part	Description	Quantity					
			24M099, KIT, hose, 3/8x15, cs, laminate	24M100, KIT, hose, 1/2x10, cs, silicone	24M101, KIT, hose, 1/4x10, cs, silicone	24M102, KIT, hose, 1/4x15, cs, laminate	24M103, KIT, hose, 1/2x10, ss, silicone	24M104, KIT, hose, 1/4x10, ss, silicone
1202	117677	FITTING, reducer -06 JIC x -10 JIC	1		1	1		
	16A362	FITTING, reducer -06 JIC x -10 JIC, ss						1
1203	262192	HOSE, b, 10', 1/2, moisture-lok, ms, -10 JIC		1				
	262176	HOSE, b, 10', 1/4, moisture-lok, ms, -06 JIC			1	1		
	262184	HOSE, b, 10', 3/8, moisture-lok, ms, -06 JIC	1					
	262255	HOSE, b, 10', 1/2, moisture-lok, ss, -10 JIC					1	
	262239	HOSE, b, 10', 1/4, moisture-lok, ss, -06 JIC						1
1204	262174	HOSE, b, 5', 1/4, moisture-lok, ms				1		
	262182	HOSE, b, 5', 3/8, moisture-lok, ms	1					
1205	117506	FITTING, swivel, 1/4 npt x -06 JIC	1		1	1		
	261668	FITTING, swivel, 1/4npt x -10 JIC		1				
	262210	FITTING, swivel, 1/4npt x -10 JIC					1	
	262206	FITTING, swivel, 1/4 npt x -06 JIC						1

A (Red) Side Hoses								
Ref	Part	Description	Quantity					
			24M105, KIT, hose, 1/2x10, cs, silicone	24M106, KIT, hose, 3/8x15, cs, laminate	24M107, KIT, hose, 1/4x10, cs, silicone	24M108, KIT, hose, 1/2x10, ss, silicone	24M109, KIT, hose, 1/4x10, ss, silicone	24M110, KIT, hose, 3/16x10, ss, silicone
1201	94/0304/98	FITTING, elbw, strt, 45, 1/2npt, mf, ss						1
1202	122767	BUSHING, 1/2x1/4npt, mf, ss, 6k, 316						1
	117502	FITTING, reducer -05 JIC x -08 JIC		1	1			
	16A361	FITTING, reducer, -05 JIC x -08 JIC, sst					1	
1203	262191	HOSE, a, 10', 1/2, moisture-lok, ms, -08 JIC	1					
	262254	HOSE, a, 10', 1/2, moisture-lok, ss, -08 JIC				1		
	262175	HOSE, a, 10', 1/4, moisture-lok, ms, -05 JIC			1			
	262238	HOSE, a, 10', 1/4, moisture-lok, ss, -05 JIC					1	
	262183	HOSE, a, 10', 3/8, moisture-lok, ms, -05 JIC		1				
	16C506	HOSE, assy, ss brd, 3/16x120, ss, -03 JIC						1
1204	262181	HOSE, a, 5', 3/8, moisture-lok, ms		1				
1205	124846	FITTING, adpt, JIC03x1/4npt, mm, ss, 6						2
	117595	FITTING, swivel, 1/4 npt x -05 JIC		1	1			
	261667	FITTING, swivel, 1/4npt x -08 JIC	1					
	262208	FITTING, swivel, 1/4npt x -08 JIC				1		
	262205	FITTING, swivel, 1/4npt x -05 JIC					1	

Inlet Hose Assembly Kits

24M181 Shown

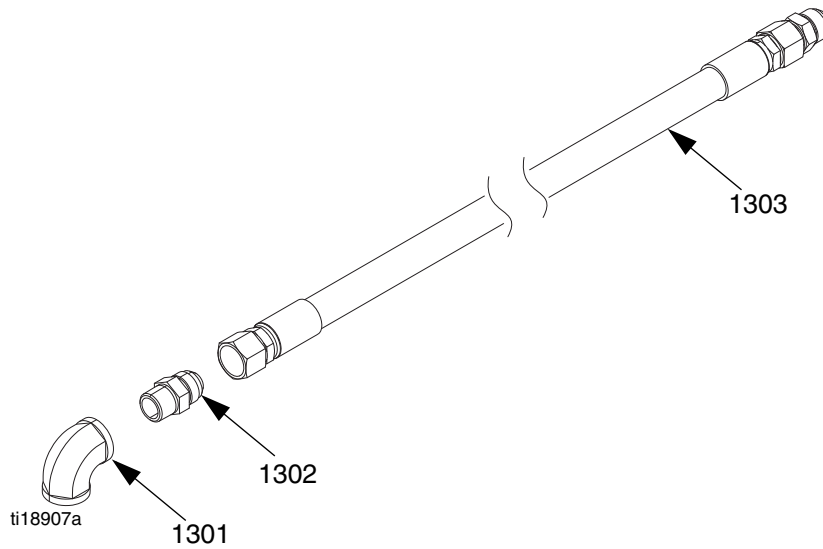

FIG. 24: Inlet Hose Assembly Kits

Ref	Part	Description	Quantity	
			24M181, KIT, hose, 3/4x15, inlet, cs	24M182, KIT, hose, 3/4x15, inlet, ss
1301	122764	FITTING, elbow, 3/4npt, f, 90deg, ss		1
	112040	FITTING, elbow, 90 deg.	1	
1302	124406	FITTING, adapter, 3/4npt x 12jic, ms	1	
	15M863	FITTING, connector, male		1
1303	24F710	HOSE, cpId, 180l, 3/4id, 1-1/16jic, female x female		1
	24M225	HOSE, cpId, 180l, 3/4id, male x female	1	

Lubrication Kit, 24M154

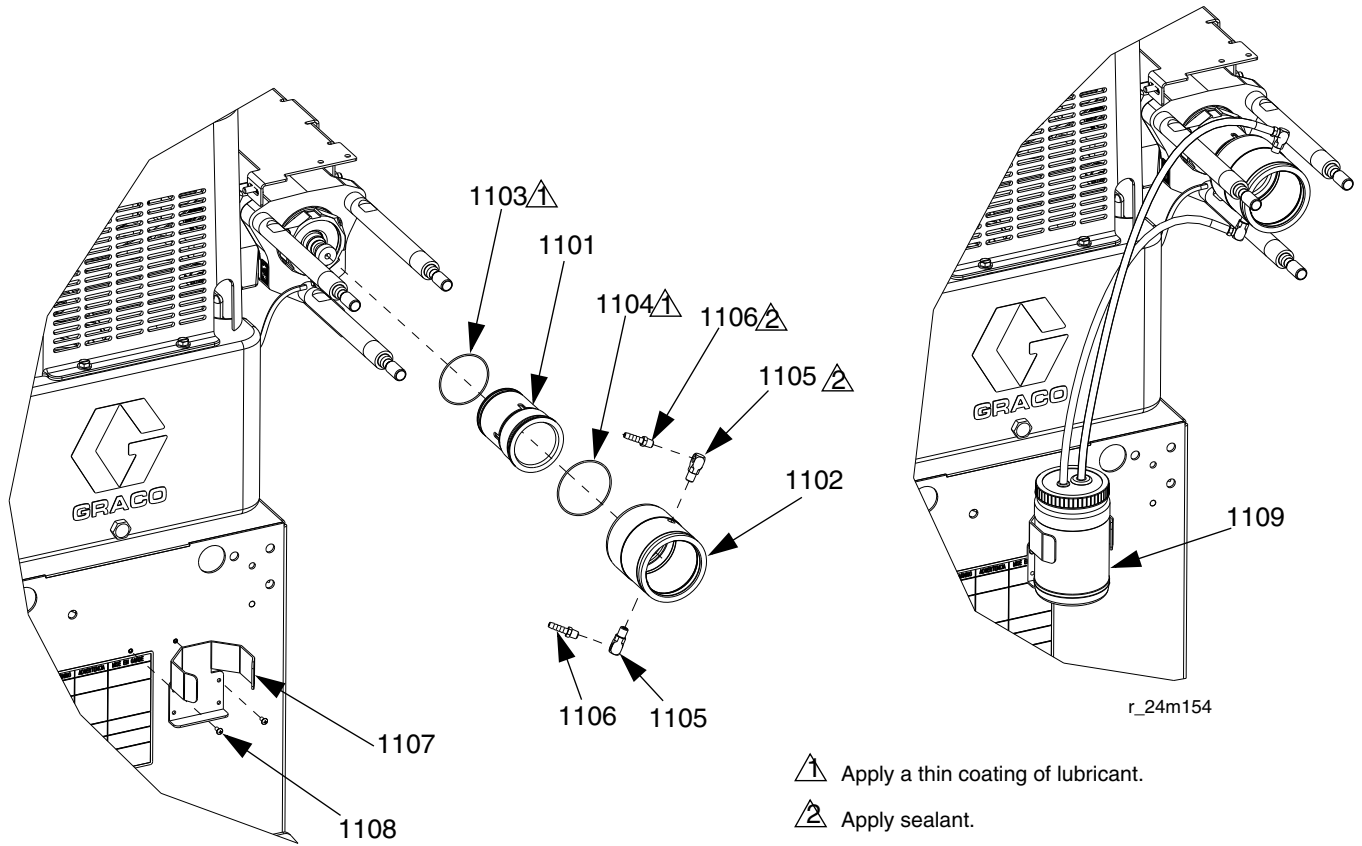

FIG. 25: Lubrication Kit

Ref	Part	Description	Qty
1101	15Y595	HOUSING, iso lube, telescoping	1
1102	15Y596	HOUSING, iso lube, telescoping	1
1103	122892	O-RING, 038	1
1104	C20278	PACKING, o-ring	1
1105	191892	FITTING, elbow, street, 90 deg	2
1106	116746	FITTING, barbed, plated	2
1107	297216	BRACKET, reservoir, lube, painted	1
1108	295187	SCREW, machine, ph, 8x3/8	2
1109	258707	RESERVOIR, bottle, assembly	1
1110	---	LUBRICANT, grease	1
1111	---	SEALANT, pipe, sst	1

--- Not for sale.

Logic Drawings

230V, 1 Phase

THIS PAGE IS FOR ASSEMBLY: 24M034
LOCATED IN THE BASE CUBE ENCLOSURE
CUSTOMER MUST SUPPLY BRANCH CIRCUIT PROTECTION

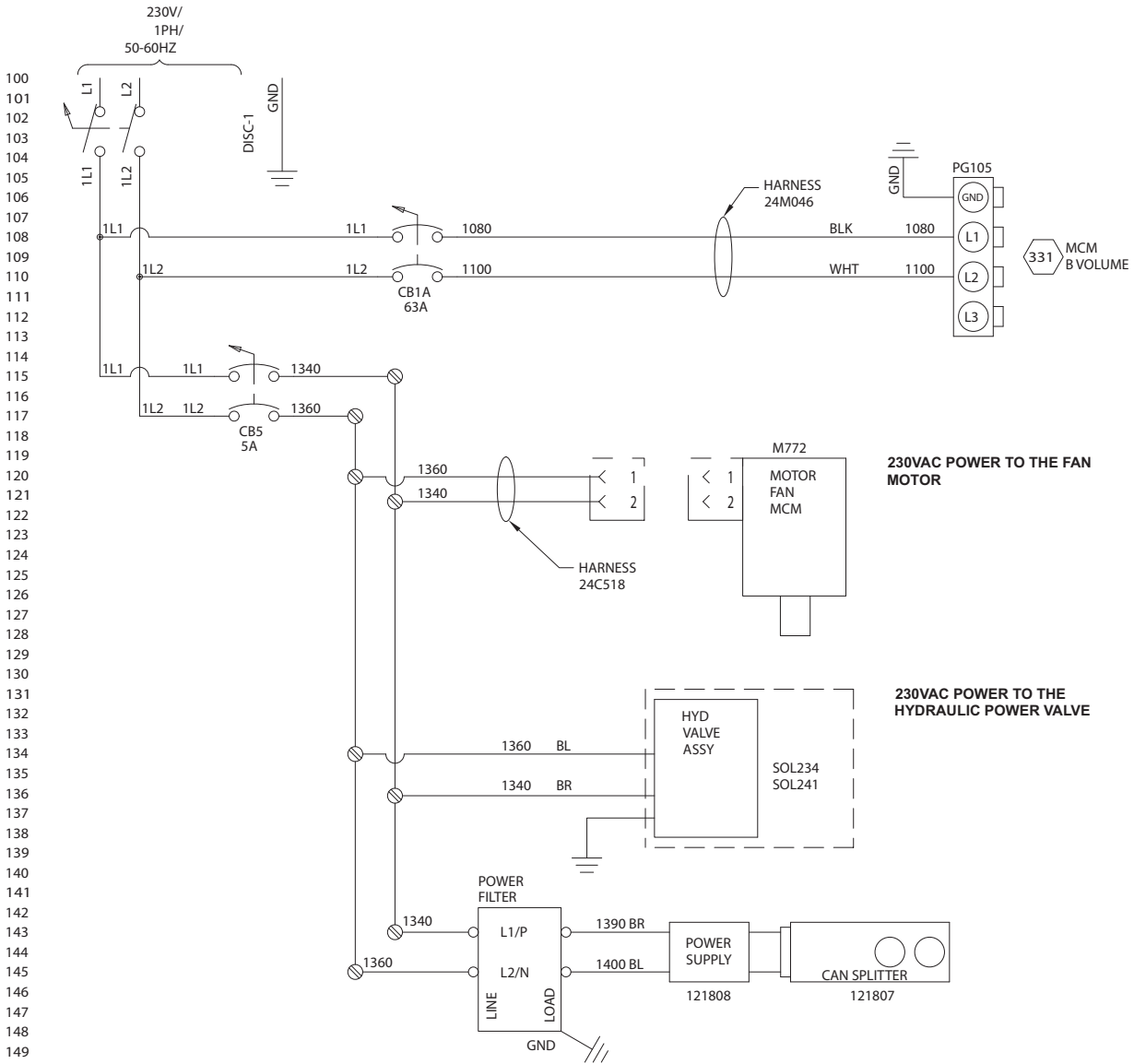

ti18273a

Fig. 26: 230V, 1 Phase, No Heat Logic Drawing; Page 1 of 1

400V, 3 Phase

THIS PAGE IS FOR ASSEMBLY: 24M035
 LOCATED IN THE BASE CUBE ENCLOSURE
 CUSTOMER MUST SUPPLY BRANCH CIRCUIT PROTECTION

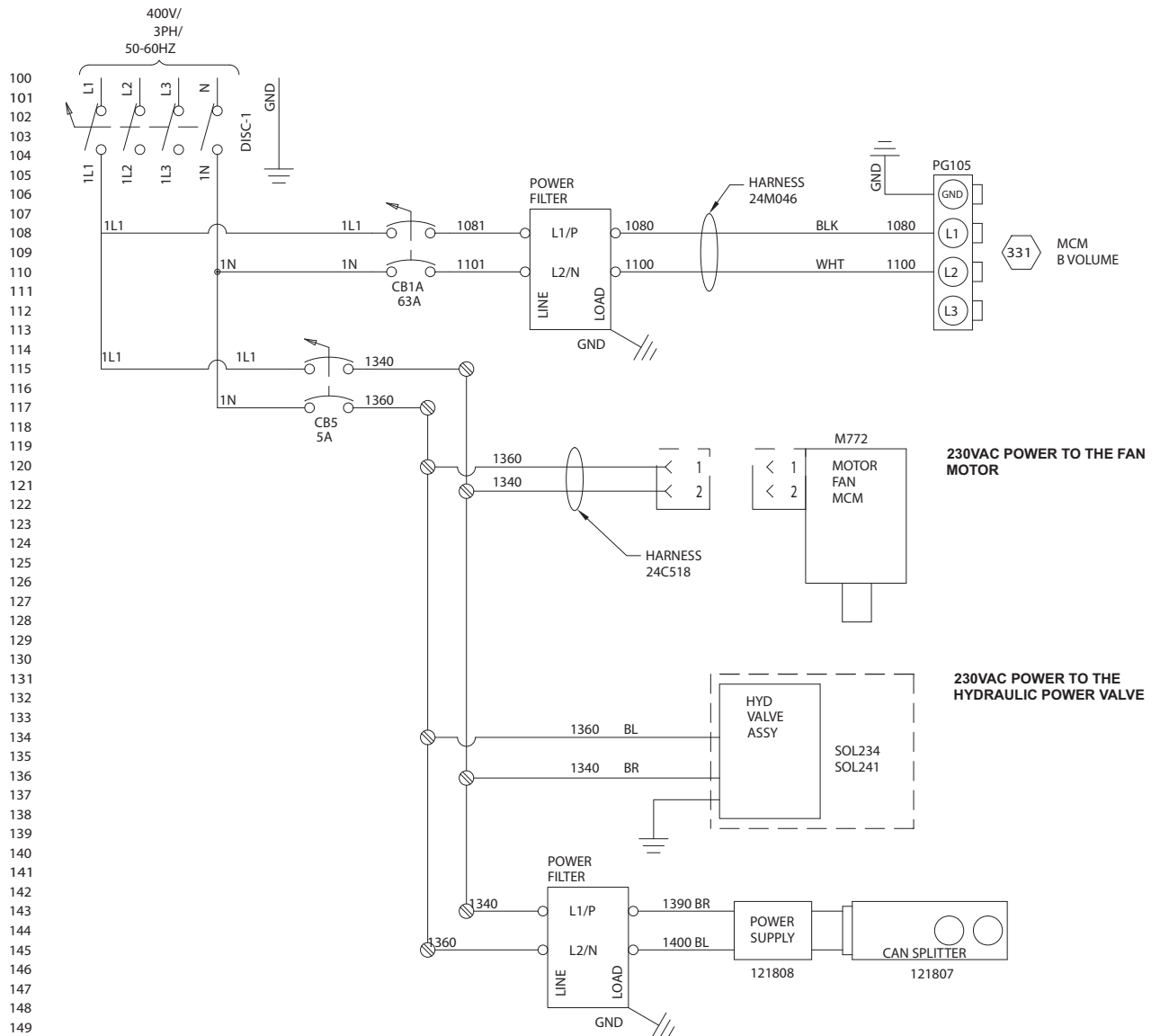

ti18274a

FIG. 27: 400V, 3 Phase, No Heat Logic Drawing; Page 1 of 1

DC Hydraulic Power Pack

890
891
892
893
894
895
896
897
898
899
900
901
902
903
904
905
906
907
908
909
910
911
912
913
914
915
916
917
918
919
920
921
922
923
924
925
926
927
928
929
930
931
932
933
934
935
936
937
938
939
940
941
942
943
944
945
946
947
948
949
950
951
952
953
954
955
956
957
958

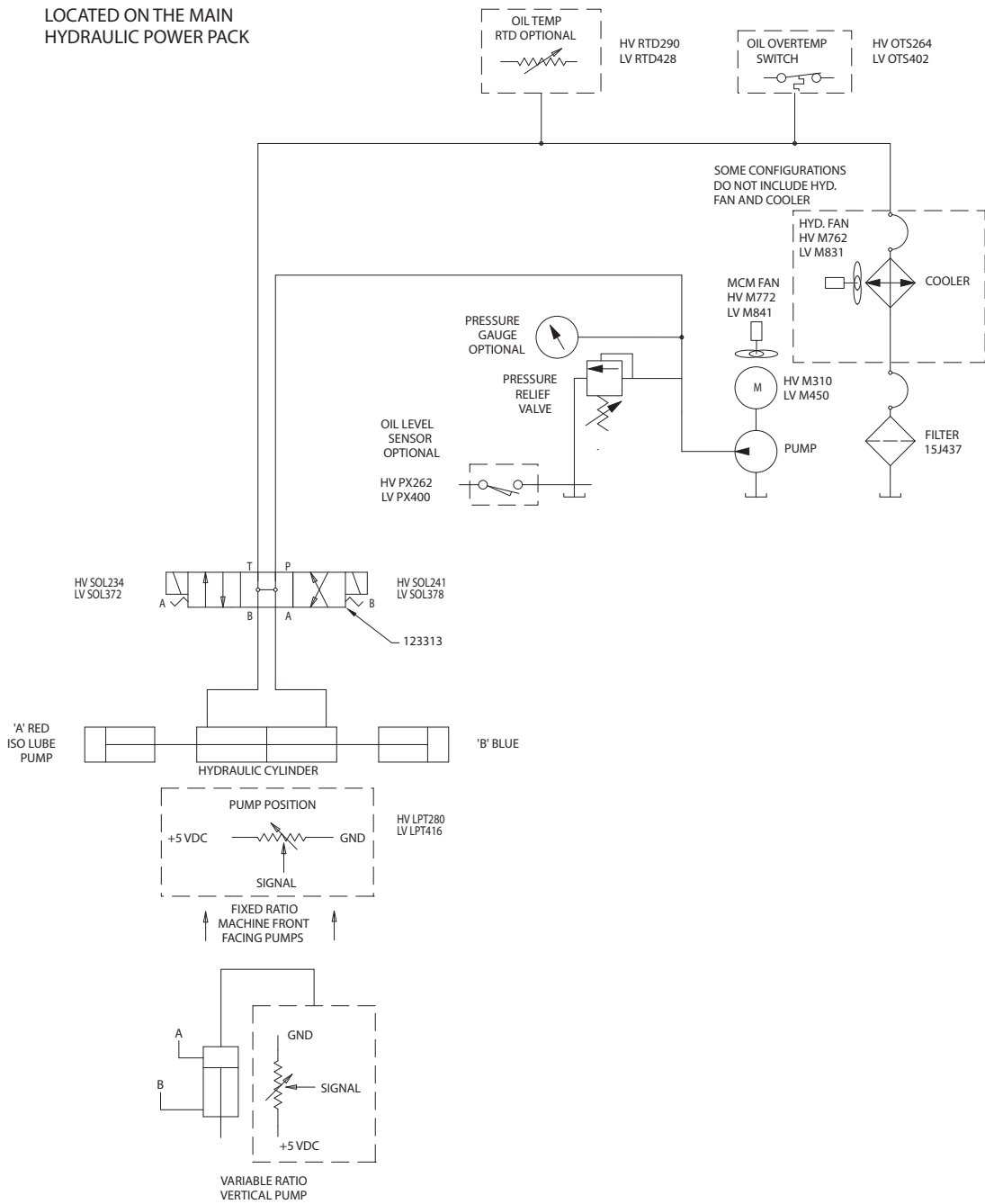

ti18275a

FIG. 28: DC Hydraulic Power Pack Logic Drawing, Page 1 of 1

Motor Control Module (MCM)

200
201
202
203
204
205
206
207
208
209
210
211
212
213
214
215
216
217
218
219
220
221
222
223
224
225
226
227
228
229
230
231
232
233
234
235
236
237
238
239
240
241
242
243
244
245
246
247
248
249
250
251
252
253
254
255
256
257
258
259
260
261
262
263
264
265
266
267
268

LOCATED ON THE HYDRAULIC
POWER PACK - FIXED RATIO

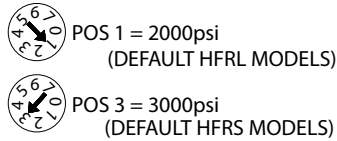

CAN COMM PORT

CAN COMM PORT

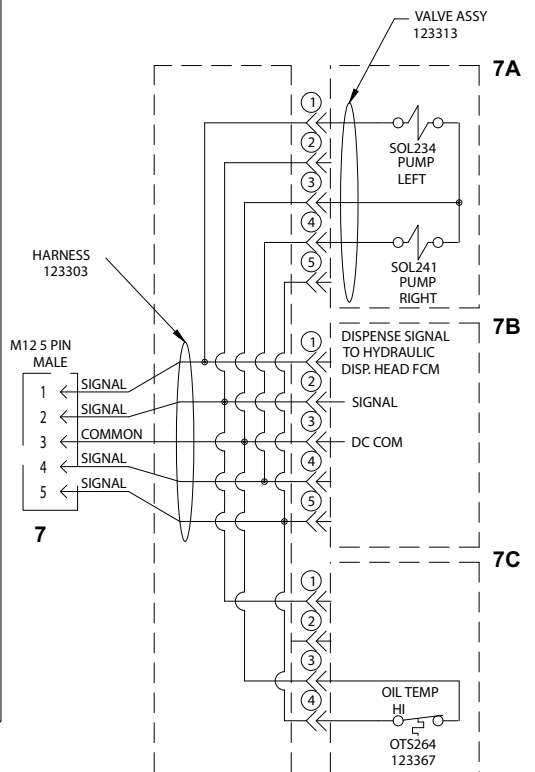
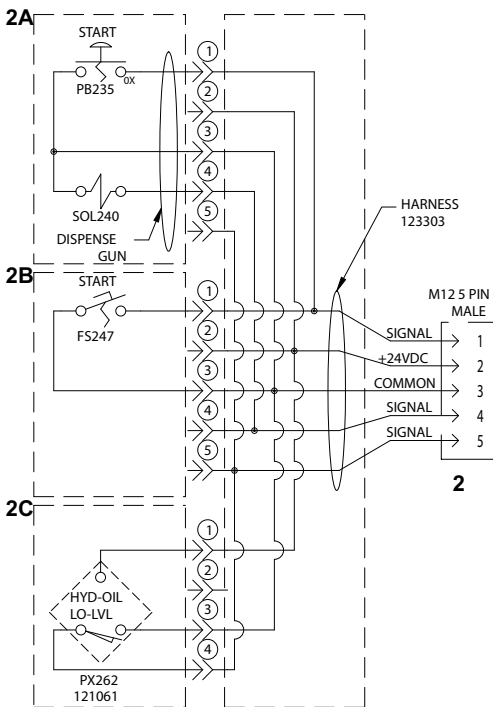
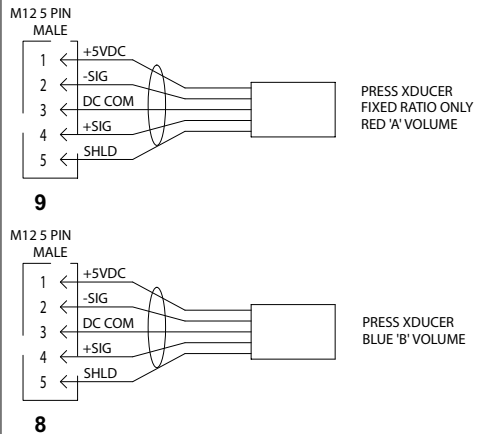
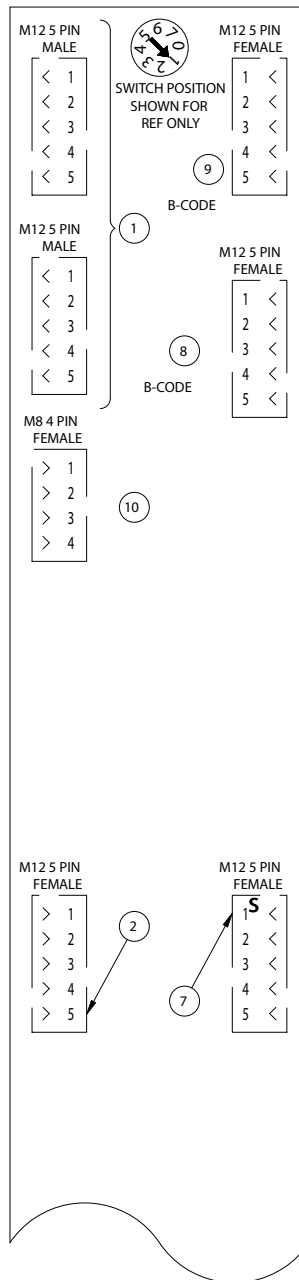

Fig. 29: Motor Control Module (MCM) Logic Drawing, Page 1 of 2

269
270
271
272
273
274
275
276
277
278
279
280
281
282
283
284
285
286
287
288
289
290
291
292
293
294
295
296
297
298
299
300
301
302
303
304
305
306
307
308
309
310
311
312
313
314
315
316
317
318
319
320
321
322
323
324
325
326
327
328
329
330
331
332
333
334
335
336
337

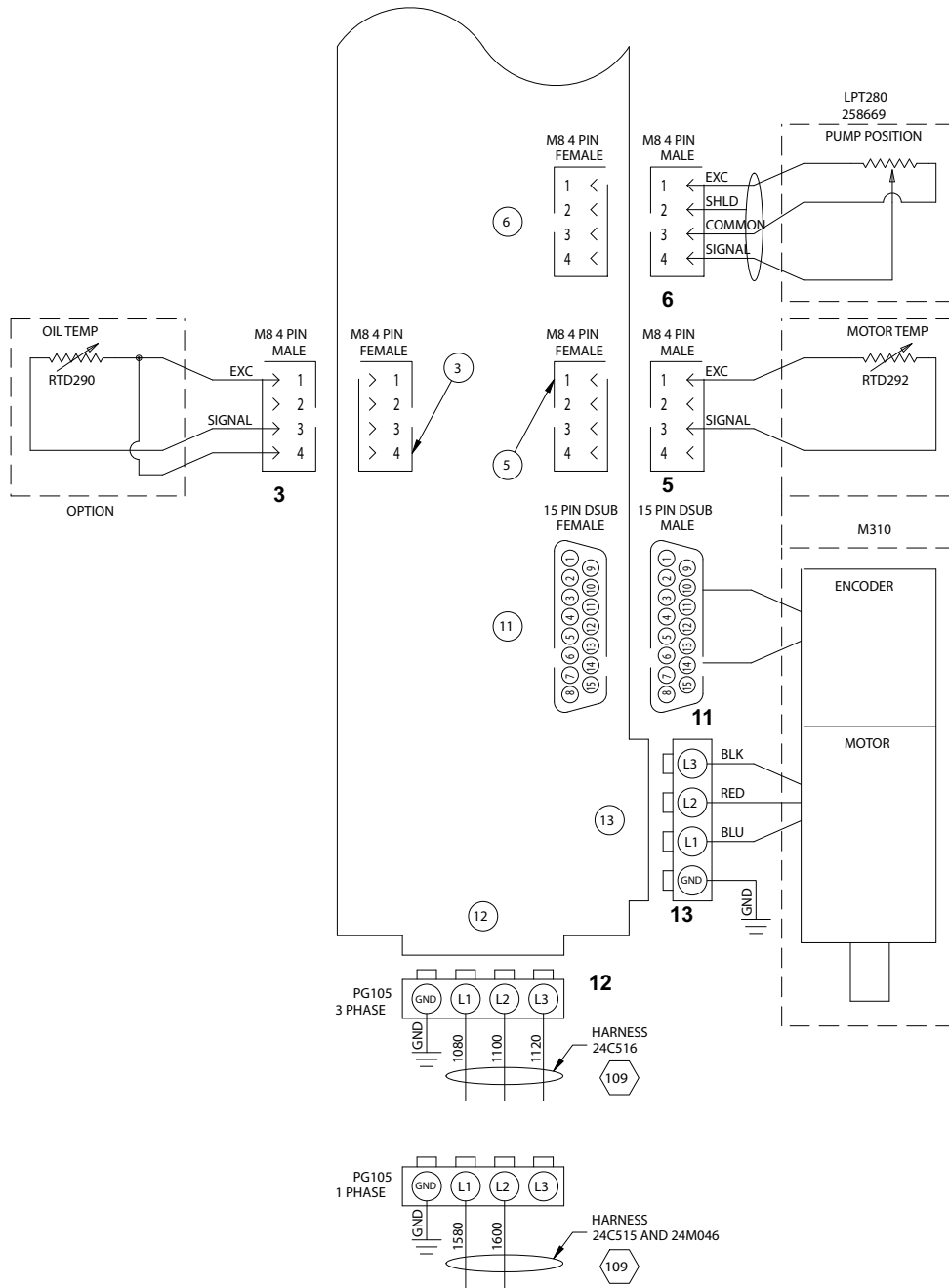

FIG. 30: Motor Control Module (MCM) Logic Drawing, Page 2 of 2

Accessories

Part No.	Description
24M154	IsoGuard® Select Assembly with 32 oz reservoir (Included on HFRL units)
24F516	IsoGuard® Select Fluid, 6 Quarts
255244	Footswitch with Guard and 4 meter cable
255468	Light Tower Kit
255208	MD2 handle, electric switch
123660	MD2 signal extension cable, 3 meter (10 ft)

HFR Discrete Gateway Module (DGM) Kits

Single DGM Kit, 24F843

Dual DGM Kit, 24F844

DGM only, 24G830

The HFR Discrete Gateway Module (DGM) allows the user to control an HFR through an external control device such as a PLC. The DGM operates in conjunction with the existing Advanced Display Module (ADM) such that both devices can be used to control the machine. See HFR Discrete Gateway Module manual 3A1149 for more information.

Secondary Supply Pump to Create a Tandem Unit (HFRS Equipment Only)

Part No.	Drum/Ram Size gallon (liter)	Type	Displacement	Ratio
24M228	5 (19)	Carbon Steel	60 cc	20:1
24M226	55 (208)			
24M229	5 (19)	Stainless Steel		
24M227	55 (208)			

Technical Data

Maximum Fluid Working Pressure:

HFRL Models 2000 psi (14 MPa, 138 bar) ‡

HFRS Models 3000 psi (21MPa, 207 bar) ‡

See **Models** starting on page 4 for specific flow rate and pressure information

Maximum Fluid Temperature 120°F (50°C)

Fluid Inlet Pressure at Inlet Fitting:

HFRL Models 50 psi (345 kPa, 3.4 bar) to 250 psi (1.8 MPa, 18 bar)

HFRS Models:

Regulator Inlet 250 psi (1.8 MPa, 18 bar) to 3000 psi (21 MPa, 207 bar)

Pump Inlet (Regulator Outlet) . 250 psi (1.8 MPa, 18 bar) to 1500 psi (10 MPa, 103 bar)

Fluid Inlets *Component A (Red):* 3/4 npt(f)

Component B (Blue): 3/4 npt(f)

Fluid Outlets on Manifold *Component A (Red):* 1/2 in. npt(f)

Component B (Blue): 1/2 in. npt(f)

Air Inlet 1/4 NPS

Air Inlet Pressure 40 psi (280 kPa, 2.8 bar) to 100 psi (0.7 MPa, 7 bar)

Fluid Circulation Ports 1/4 npsm(m), with plastic tubing, 250 psi (1.8 MPa, 18 bar) maximum

Line Voltage Requirement 230V / 1 phase: 195-264V, 50/60 Hz

400V / 3 phase: 360-440V, 50/60 Hz; see **400 V Power Requirements** on page 5 and 9; ★

Peak Amperage Requirement 55A per phase @ full load *

System Watts 12,650

Sound Power 93 dB

Hydraulic reservoir capacity 8 gal. (30 liters)

Recommended hydraulic fluid Citgo A/W Hydraulic Oil, ISO Grade 46

Weight 634 lb (288 kg) (Not including supply pumps)

Wetted Parts Aluminum, stainless steel, zinc-plated carbon steel, brass, carbide, chrome, fluoroelastomer, PTFE, ultra-high molecular weight polyethylene, chemically resistant o-rings

All other brand names or marks are used for identification purposes and are trademarks of their respective owners.

* *Full load amps with all devices operating at maximum capabilities. Fuse requirements at various flow rates and mix chamber sizes may be less.*

★  approved.

‡ *The maximum fluid working pressure for the base machine without hoses is 3000 psi (20.7 MPa, 207 bar). If hoses rated at less than 3000 psi are installed, the system maximum fluid working pressure becomes the rating of the hoses. If 2000 psi hoses were purchased and installed by Graco, the working pressure for the machine is already setup for the lower 2000 psi (13.8 MPa, 138 bar) working pressure by Graco. If the machine was purchased without hoses and aftermarket hoses rated at or above 3000 psi are to be installed, see instruction manual 3A1276 for the procedure to setup the machine for higher rated hoses. The change in working pressure is made by changing a rotary switch setting in the Motor Control Module. The minimum pressure rating for hoses is 2000 psi. Do not install hoses with a pressure rating lower than 2000 psi.*

Motor Control Module Technical Data

Input Specifications

Input Line Voltage	0-264 Vac, line-to-line
Input Line Phasing	Single or Three Phase
Input Line Frequency	50/60 Hz
Input Current per Phase.	25A (three-phase), 50A (single-phase)
Maximum Branch Circuit Protection Rating:	30A (three-phase), 63A (single-phase)
Short Circuit Current Rating.	5 kA

Output Specifications

Output Line Voltage	0-264 Vac
Output Line Phasing	Three Phase
Output Current	0-30A
Output Overload.	200% for 0.2 seconds

DC Power Supply	24 Vdc, Class 2, Graco-provided power supply
Enclosure	Type 1
Max Ambient Temperature	50°C (122°F)

Overtemperature protection is provided to protect from motor overload.

Current limit, set via the software, is provided as a secondary protection from motor overload.

All installations and wiring must comply with NEC and local electrical codes.

Graco Standard Warranty

Graco warrants all equipment referenced in this document which is manufactured by Graco and bearing its name to be free from defects in material and workmanship on the date of sale to the original purchaser for use. With the exception of any special, extended, or limited warranty published by Graco, Graco will, for a period of twelve months from the date of sale, repair or replace any part of the equipment determined by Graco to be defective. This warranty applies only when the equipment is installed, operated and maintained in accordance with Graco's written recommendations.

This warranty does not cover, and Graco shall not be liable for general wear and tear, or any malfunction, damage or wear caused by faulty installation, misapplication, abrasion, corrosion, inadequate or improper maintenance, negligence, accident, tampering, or substitution of non-Graco component parts. Nor shall Graco be liable for malfunction, damage or wear caused by the incompatibility of Graco equipment with structures, accessories, equipment or materials not supplied by Graco, or the improper design, manufacture, installation, operation or maintenance of structures, accessories, equipment or materials not supplied by Graco.

This warranty is conditioned upon the prepaid return of the equipment claimed to be defective to an authorized Graco distributor for verification of the claimed defect. If the claimed defect is verified, Graco will repair or replace free of charge any defective parts. The equipment will be returned to the original purchaser transportation prepaid. If inspection of the equipment does not disclose any defect in material or workmanship, repairs will be made at a reasonable charge, which charges may include the costs of parts, labor, and transportation.

THIS WARRANTY IS EXCLUSIVE, AND IS IN LIEU OF ANY OTHER WARRANTIES, EXPRESS OR IMPLIED, INCLUDING BUT NOT LIMITED TO WARRANTY OF MERCHANTABILITY OR WARRANTY OF FITNESS FOR A PARTICULAR PURPOSE.

Graco's sole obligation and buyer's sole remedy for any breach of warranty shall be as set forth above. The buyer agrees that no other remedy (including, but not limited to, incidental or consequential damages for lost profits, lost sales, injury to person or property, or any other incidental or consequential loss) shall be available. Any action for breach of warranty must be brought within two (2) years of the date of sale.

GRACO MAKES NO WARRANTY, AND DISCLAIMS ALL IMPLIED WARRANTIES OF MERCHANTABILITY AND FITNESS FOR A PARTICULAR PURPOSE, IN CONNECTION WITH ACCESSORIES, EQUIPMENT, MATERIALS OR COMPONENTS SOLD BUT NOT MANUFACTURED BY GRACO. These items sold, but not manufactured by Graco (such as electric motors, switches, hose, etc.), are subject to the warranty, if any, of their manufacturer. Graco will provide purchaser with reasonable assistance in making any claim for breach of these warranties.

In no event will Graco be liable for indirect, incidental, special or consequential damages resulting from Graco supplying equipment hereunder, or the furnishing, performance, or use of any products or other goods sold hereto, whether due to a breach of contract, breach of warranty, the negligence of Graco, or otherwise.

FOR GRACO CANADA CUSTOMERS

The Parties acknowledge that they have required that the present document, as well as all documents, notices and legal proceedings entered into, given or instituted pursuant hereto or relating directly or indirectly hereto, be drawn up in English. Les parties reconnaissent avoir convenu que la rédaction du présente document sera en Anglais, ainsi que tous documents, avis et procédures judiciaires exécutés, donnés ou intentés, à la suite de ou en rapport, directement ou indirectement, avec les procédures concernées.

Graco Information

Sealant and Adhesive Dispensing Equipment

For the latest information about Graco products, visit www.graco.com.

For patent information, see www.graco.com/patents.

TO PLACE AN ORDER, contact your Graco distributor, go to www.graco.com and select "Where to Buy" in the top blue bar, or call to find the nearest distributor.

If calling from the US: 800-746-1334

If calling from outside the US: 0-1-330-966-3000

All written and visual data contained in this document reflects the latest product information available at the time of publication. Graco reserves the right to make changes at any time without notice.

Original instructions. This manual contains English. MM 3A2176

Graco Headquarters: Minneapolis

International Offices: Belgium, China, Japan, Korea

GRACO INC. AND SUBSIDIARIES • P.O. BOX 1441 • MINNEAPOLIS MN 55440-1441 • USA

Copyright 2011, Graco Inc. All Graco manufacturing locations are registered to ISO 9001.

www.graco.com

Revision K, February 2017