

Merkur[®] Displacement Pump

312792H
EN

For use with high-performance finishing and coating pumps in hazardous and non-hazardous locations. For professional use only.



Important Safety Instructions

Read all warnings and instructions in this manual. For complete warnings and instructions see your pump or package manual. Hazard symbols refer to specific procedure risks. Save all instructions.

See page 3 for model information, including maximum working pressures.

LW025A

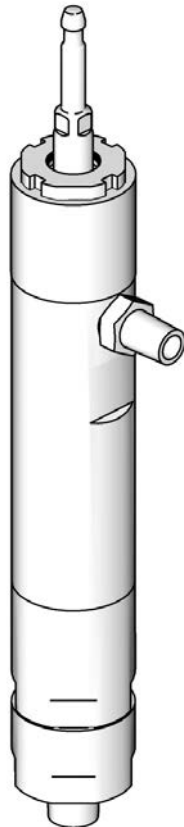

TI11643a

LW150A

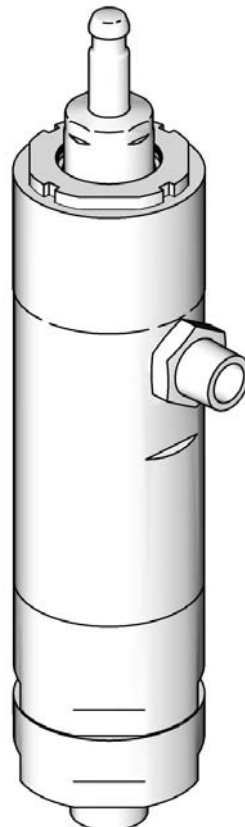

TI11645

Contents

Related Manuals	2	Parts	9
Models	3	Standard Repair Kits	11
Component Identification	4	Optional Kits	11
Repair	5	Dimensions	12
General Information	5	Technical Data	13
Preparation	5	Graco Standard Warranty	14
Disassembly	5	Graco Information	14
Reassembly	6		

Related Manuals

Manual	Description
312796	NXT™ Air Motor
312794	Merkur Pump Assembly
312797	Merkur Spray Packages, ambient, AA and Airless
312798	Merkur Electrostatic Spray Packages
313255	Merkur Heated Spray Packages

Models

Check your displacement pump's identification marking for the 6-digit part number. Use the following matrix to define the construction of your displacement pump. For example, displacement pump model LW025A represents a wet-cup style stainless steel displacement pump, 25 cc, with a Chromex coated rod and 3 UHMWPE, 2 PTFE packings.



ti12415a

To order replacement parts, see **Parts** section starting on page 9. The digits in the matrix do not correspond to the reference numbers in the Parts drawings and lists.

L	W		025	A	
First Digit	Second Digit (Description)		Third, Fourth, and Fifth Digits (Displacement Pump Volume Per Cycle* in cc)	Sixth Digit (Packings; Displacement Rod Coating)	
L (Lower)	W	Wet-cup style, stainless steel	025	A	3 UHMWPE, 2 PTFE; Chromex™
			050		
			075		
			100		
			125		
			150		

* Cycle refers to combination of one upstroke and one downstroke.

Model, Series	Maximum Working Pressure psi (MPa, bar)	Fluid Inlet	Fluid Outlet
LW025A, Series A	3000 (20.7, 207)	1/2 in. npt	3/8 in. npt
LW050A, Series A	4500 (31.0, 310)	3/4 in. npt	3/8 in. npt
LW075A, Series A	4800 (33.1, 331)	3/4 in. npt	3/8 in. npt
LW100A, Series A	3600 (24.8, 248)	3/4 in. npt	3/8 in. npt
LW125A, Series A	2900 (20.0, 200)	1 in. npt	1/2 in. npt
LW150A, Series A	2400 (16.5, 165)	1 in. npt	3/4 in. npt

Component Identification

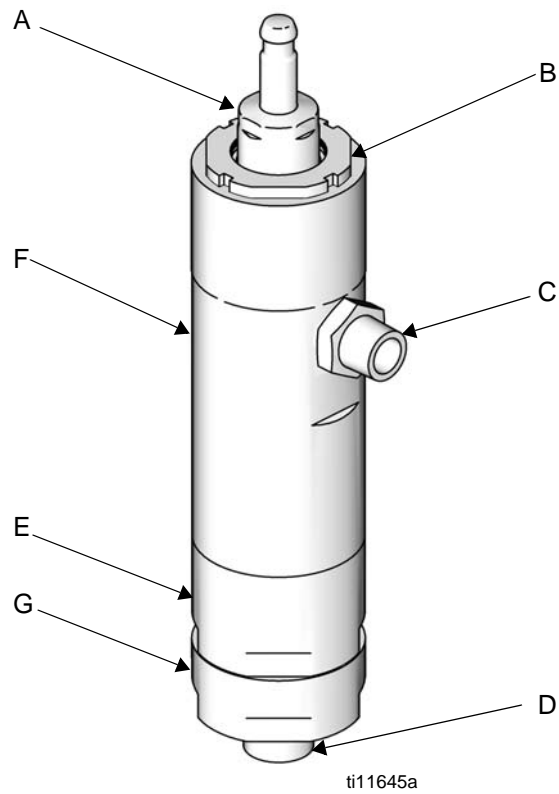

FIG. 1. Component Identification

Key:

- A Piston/Rod Assembly
- B Wet Cup
- C Fluid Outlet
- D Fluid Inlet
- E Lower Cylinder
- F Upper Cylinder
- G Intake Valve

Repair



General Information

NOTICE

Reference numbers and letters in parentheses in the text refer to the callouts in the figures and the parts drawing.

Always use Genuine Graco Parts and Accessories, available from your Graco distributor. If you supply your own accessories, be sure they are adequately sized and pressure rated for your system.

Preparation



Follow all warnings and instructions in your pump manual for the following preliminary steps:

1. Flush the equipment.
2. Relieve the pressure.
3. Remove the displacement pump from the pump assembly.

Disassembly

Lay out all removed parts in sequence to ease reassembly. Clean all parts with a compatible solvent and inspect them for wear or damage.

NOTICE

Repair Kits are available. See the chart on page 11 to order the correct kit(s) for your pump.

- Parts included in the Seal Repair Kit are marked with an *, for example 8*.
- Parts included in the Seat Repair Kit are marked with a †.
- Parts included in the Check Ball Kit are marked with a ◆.



Threads are very sharp. Use a rag to protect hands.

1. Place cylinder (1) sideways in a vise with soft jaws.
2. Use an adjustable wrench on hex of intake housing (23) to unscrew it from the lower cylinder (2). Loosen vice briefly and tip out the ball (24◆).

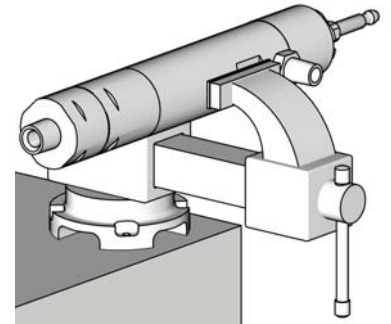

ti12918a

3. Remove the seat (22†) and use an o-ring pick to remove the seal (26†) from the intake housing. See FIG. 7.
4. Use an adjustable wrench on hex of lower cylinder (2) to remove it from the upper cylinder (1) and slide it straight off the pump. Be careful not to damage the piston/rod assembly (3).
5. Remove the o-ring (21*†) from the top of the lower cylinder.
6. Loosen the wet cup (5).
7. Pull the piston/rod assembly out the bottom of the upper cylinder. Remove the spring (10*), piston packings (12* and 13*) and glands (11* and 14*).
8. Remove the wet cup (5).
9. Remove the throat packings (7*, 8*) and glands (6*, 9*) from the bottom of the wet cup.

NOTICE

The jam nut can remain attached to the upper cylinder.

10. Remove the spring (4*) from the top of the upper cylinder (1).

11. Remove the wet cup seal (27*) and the upper cylinder seal (28*).
12. Clamp the piston in a vice. Use a hex wrench to remove the nut (17†) from end of piston.
 - LW025A–LW050A: 7 mm (1/4 in.) hex
 - LW075A–LW150A: 13 mm (1/2 in.) hex

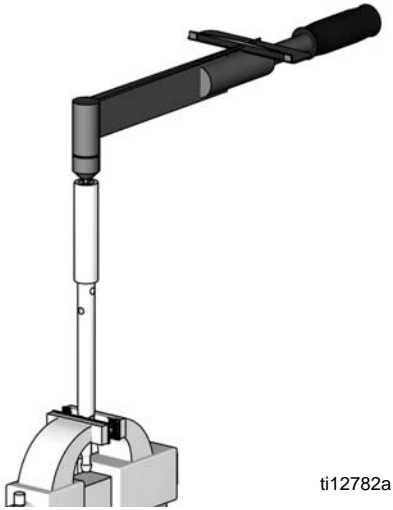

FIG. 2. Remove Flow-Through Nut

13. Remove the o-ring (18†), seat (15†) and ball (16◆). See FIG. 5.

Reassembly

1. Clean and inspect all parts.

NOTICE

Replace all o-rings removed from the pump. Compressed o-rings may cause the pump to leak.

2. Lubricate and install new wet cup seal (27*) and upper cylinder seal (28*).
3. Assemble the female gland (9*), v-packings (7*, 8*), and male gland (6*), as shown. Alternate the v-packings with the lips facing down. Lubricate the packings. Install the packing stack into the wet cup (5).

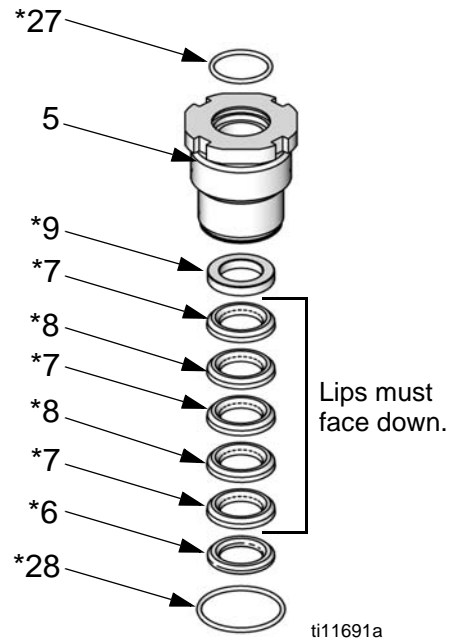

FIG. 3. Replace Throat Packings

4. Install the spring (4*) in the top of the upper cylinder.

NOTICE

All threads, packings, and seals must be well lubricated. Use Lubriplate (Graco Part Number 111920) or a similar product.

5. Lubricate the threads and screw the wet cup (5) into the upper cylinder (1), hand tight.

- Assemble the male gland (11*), v-packings (12*, 13*), and female gland (14*), as shown. Alternate the v-packings, with the lips facing up. Lubricate the packings. Install the spring (10*) and packing stack into the bottom of the upper cylinder (1).

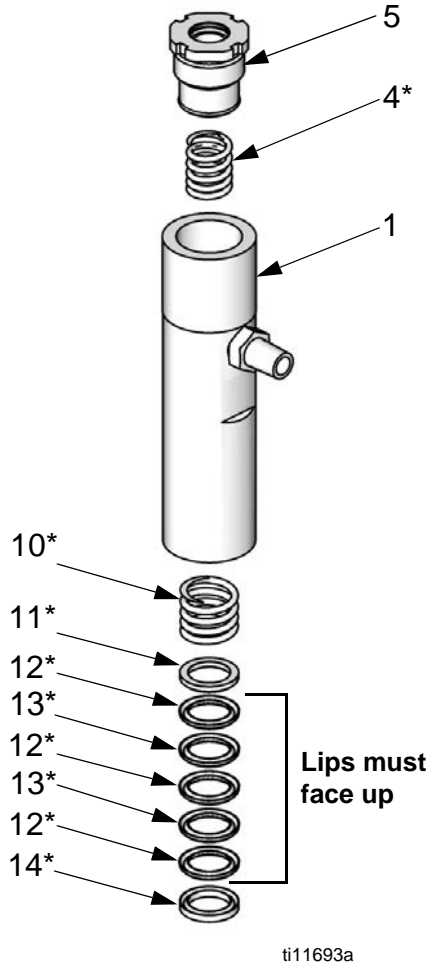

ti11693a

FIG. 4. Replace piston packings.

- Place the ball (16♦) in the piston body. Install the seat (15†) and o-ring (18†). Lubricate the o-ring and the threads of the flow-through nut (17†). Screw the flow-through nut (17†) into the piston/rod assembly (3).

- Place piston in vice and torque flow-through nut (17†) as specified in the following table.

Displacement Pump	Torque
LW025A–LW050A	58-62 ft-lb (78-84 N•m)
LW075A–LW150A	78-82 ft-lb (105-111 N•m)

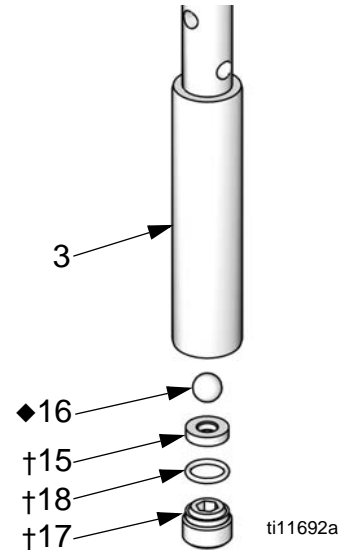

ti11692a

FIG. 5. Replace piston ball and seat.

- Push the piston/rod assembly (3) into the upper cylinder (1).
- Lubricate and install the seal (21*) on the top of the lower cylinder (2).
- Lubricate the threads and screw the lower cylinder (2) onto the upper cylinder (1). Torque to 95-105 ft-lb (128-142 N•m).

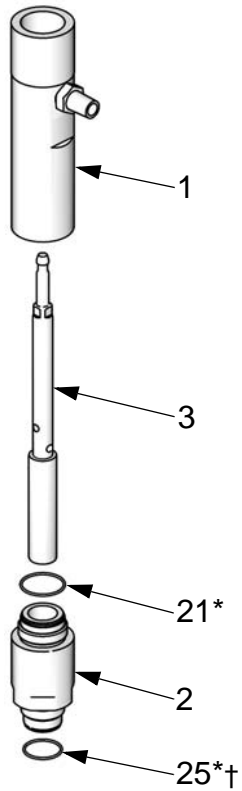

ti12414a

FIG. 6. Assemble piston/rod assembly and cylinders.

12. Lubricate and install the seal (25*†) on the bottom of the lower cylinder (2).
13. Install the o-ring (26†) and intake seat (22†) into the top of the inlet housing. Lubricate the o-ring. The seat (22†) is reversible. Turn over or replace as needed.

14. Lubricate the seal (25*†) and threads of the lower cylinder (2). Place the ball (24◆) on the seat (22†).

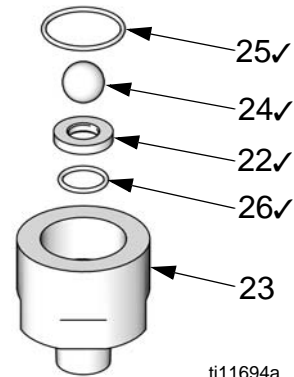

ti11694a

FIG. 7. Replace intake ball and seat.

15. Keep upright to screw the housing (23) into the lower cylinder (2) hand tight, so the seat remains firmly in place. Then clamp the cylinder in a vice and torque as specified in the following table.

Displacement Pump	Torque
LW025A–LW050A	58-62 ft-lb (78-84 N•m)
LW075A–LW150A	78-82 ft-lb (105-111 N•m)

16. Torque wet cup (5) to 58-62 ft-lb (78-84 N•m).

Parts

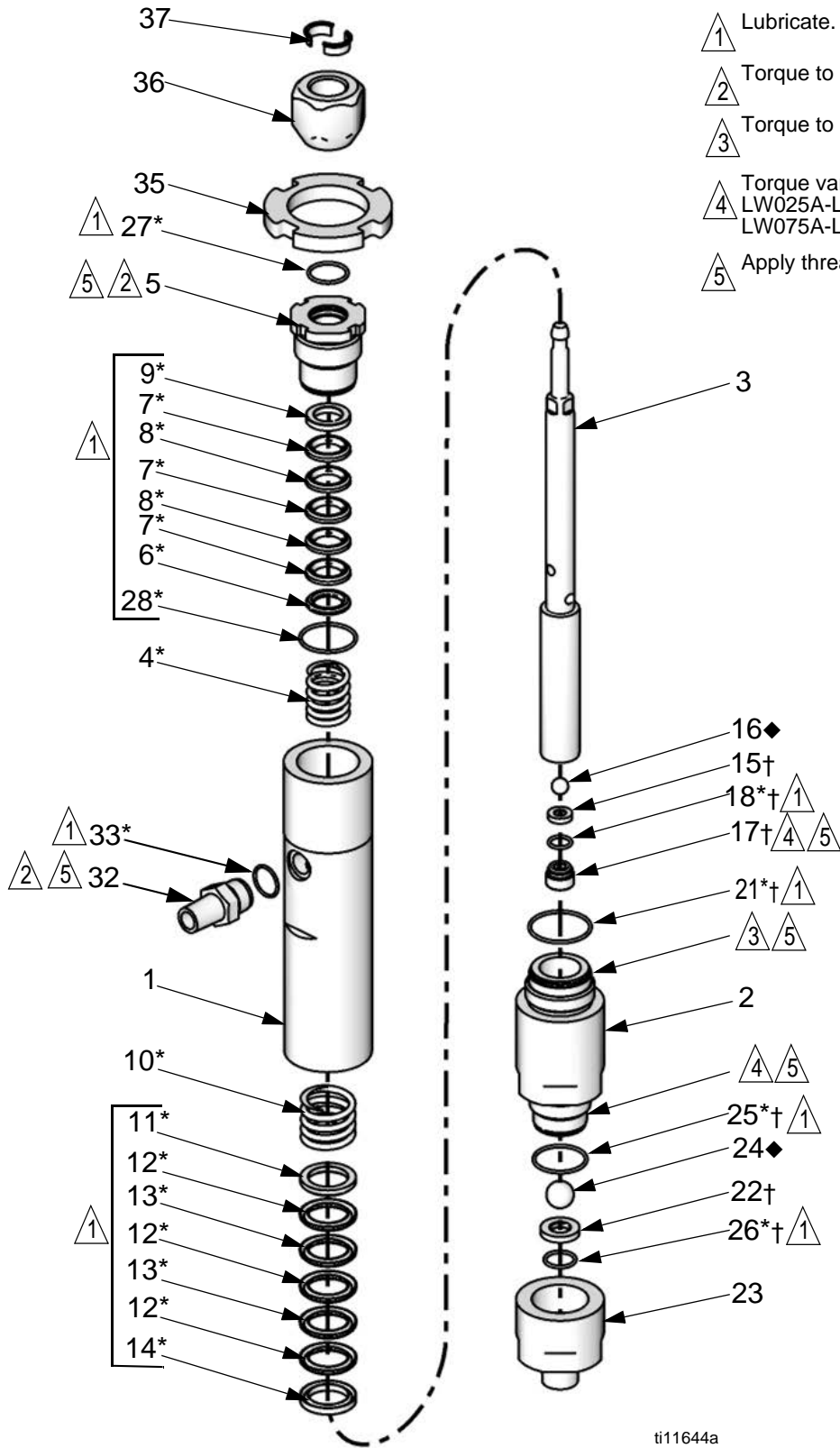

- △1 Lubricate.
- △2 Torque to 58-62 ft-lb (78-84 N•m)
- △3 Torque to 95-105 ft-lb (128-142 N•m)
- △4 Torque varies by lower size.
LW025A-LW050A: 58-62 ft-lb (78-84 N•m)
LW075A-LW150A: 78-82 ft-lb (105-111 N•m)
- △5 Apply thread lubricant.

ti11644a

Ref.	Description	Part	Qty.	
1	CYLINDER KIT, upper; includes 21, 28, 32, and 33 (qty. 1)		1	
		LW025A		24A813
		LW050A		24A814
		LW075A		24A815
		LW100A		24A816
		LW125A		24A817
LW150A	24A818			
2	CYLINDER KIT, lower; includes 21 and 25		1	
		LW025A		24A822
		LW050A		24A823
		LW075A		24A824
		LW100A		24A825
		LW125A		24A826
LW150A	24A827			
3	PISTON/ROD, assembly; includes 15-18, 36, and 37 (qty. 1)		1	
		LW025A		24A643
		LW050A		24A644
		LW075A		24A645
		LW100A		24A646
		LW125A		24A647
LW150A	24A648			
4*	SPRING, throat	-----	1	
5	WET CUP; includes 27 and 28 (qty. 1 each)		1	
		LW025A		24A807
		LW050A		24A808
		LW075A		24A809
		LW100A		24A810
		LW125A		24A811
LW150A	24A812			
6*	GLAND, male, throat	-----	1	
7*	PACKING, throat, UHMWPE	-----	3	
8*	PACKING, throat, PTFE	-----	2	
9*	GLAND, female, throat	-----	1	
10*	SPRING, piston	-----	1	
11*	GLAND, male, piston	-----	1	
12*	PACKING, piston, UHMWPE	-----	3	
13*	PACKING, piston, PTFE	-----	2	
14*	GLAND, female, piston	-----	1	
15†	SEAT, piston valve, tungsten carbide	-----	1	
16◆	BALL, piston valve, 440 stainless steel	-----	1	
17†	NUT, flow through	-----	1	
18*†	O-RING, piston	-----	1	

Ref.	Description	Part	Qty.	
21*†	O-RING, lower cylinder	-----	1	
22†	SEAT, intake valve, tungsten carbide	-----	1	
23	INTAKE VALVE KIT; includes 26		1	
		LW025A		24A834
		LW050A		24A835
		LW075A		24A836
		LW100A		24A837
		LW125A		24A838
LW150A	24A839			
24◆	BALL, intake valve, 440 stainless steel	-----	1	
25*†	O-RING, lower cylinder	-----	2	
26*†	O-RING, intake valve	-----	1	
27*	O-RING, wet cup; package of 10		1	
		LW025A		24A630
		LW050A-LW075A		24A631
		LW100A		24A632
LW125A-LW150A	24A633			
28*	O-RING, wet cup	-----	1	
32	FITTING, outlet, 3/8-18 npt X 3/4-16 unf; includes 33 (qty. 1)		1	
		LW025A-LW100A		24A840
		LW125A		24A841
		LW150A		24A842
33*	O-RING, outlet; package of 10		1	
		LW025A-LW100A		24E457
		LW125A		24E458
LW150A	24E459			
35	JAM NUT		1	
		LW025A		24A634
		LW050A		24A635
		LW075A		24A636
		LW100A		24A637
		LW125A		24A638
LW150A	24A639			
36	NUT, coupling		1	
		LW025A		15M758
LW050A-LW150A	15T311			
37	COLLAR, coupling; pkg. of 10		1	
		LW025A		24A618
		LW050A-LW150A		24A619

----- Not sold separately.

* Included in Seal Repair Kit. See page 11.

† Included in Seat Repair Kit. 316 stainless steel seats also are available. See page 11.

◆ Included in Check Ball Kit. Tungsten carbide and 316 stainless steel check balls also are available. See page 11.

Standard Repair Kits

Kit Description	LW025A	LW050A	LW075 A	LW100 A	LW125A	LW150A
* Seal Repair Kit Throat v-packings (7* and 8*) and glands (6* and 9*), piston v-packings (12* and 13*) and glands (11* and 14*), o-rings (18*, 21*, 25*, 26*, 27*, 28*, and 33*), and springs (4*and 10*)	24A251	24A252	24A253	24A254	24A255	24A256
V-Packing Repair Kit Throat v-packings (7* and 8*), piston v-packings (12* and 13*, and o-rings (18*, 21*, 25*, 26*, 27*, 28*, and 33*)	---	---	24R167	24R168	---	---
† Tungsten Carbide Seat Repair Kit Seats (15† and 22†), o-rings (18†, 21†, 25†, and 26†), and flow-through nut (17†)	24A781	24A782	24A783	24A784	24A785	24A786
◆ 440 Stainless Steel Check Ball Kit Piston ball (16◆) and intake ball (24◆)	24A261	24A261	24A263	24A264	24A264	24A264
Wet-Cup O-Ring (27) Package of 10	24A630	24A631	24A631	24A632	24A633	24A633
Coupling Collars (37) Package of 10	24A618	24A619	24A619	24A619	24A619	24A619

Optional Kits

Kit Description	LW025A	LW050A	LW075 A	LW100 A	LW125A	LW150A
Reinforced PTFE V-Packing Kit** Reinforced PTFE throat packings and glands, reinforced PTFE piston packings and glands, o-rings, and springs	24J852	24J853	24J854	24J855	24J856	24J857
†316 Stainless Steel Seat Repair Kit*** Seats (15† and 22†), o-rings (18†, 21†, 25†, and 26†), and flow-through nut (17†)	24A794	24A795	24A796	24A797	24A798	24A799
◆Check Ball Kit Piston ball (16◆) and intake ball (24◆)						
316 Stainless Steel***	24P612	24P612	24P613	24P614	24P614	24P614
Tungsten Carbide	24A667	24A667	24A669	24A670	24A670	24A670

** Use with materials that cause chemical compatibility concerns with UHMWPE, such as acid catalyst materials.

*** Replaces standard kits for high corrosive applications.

Dimensions

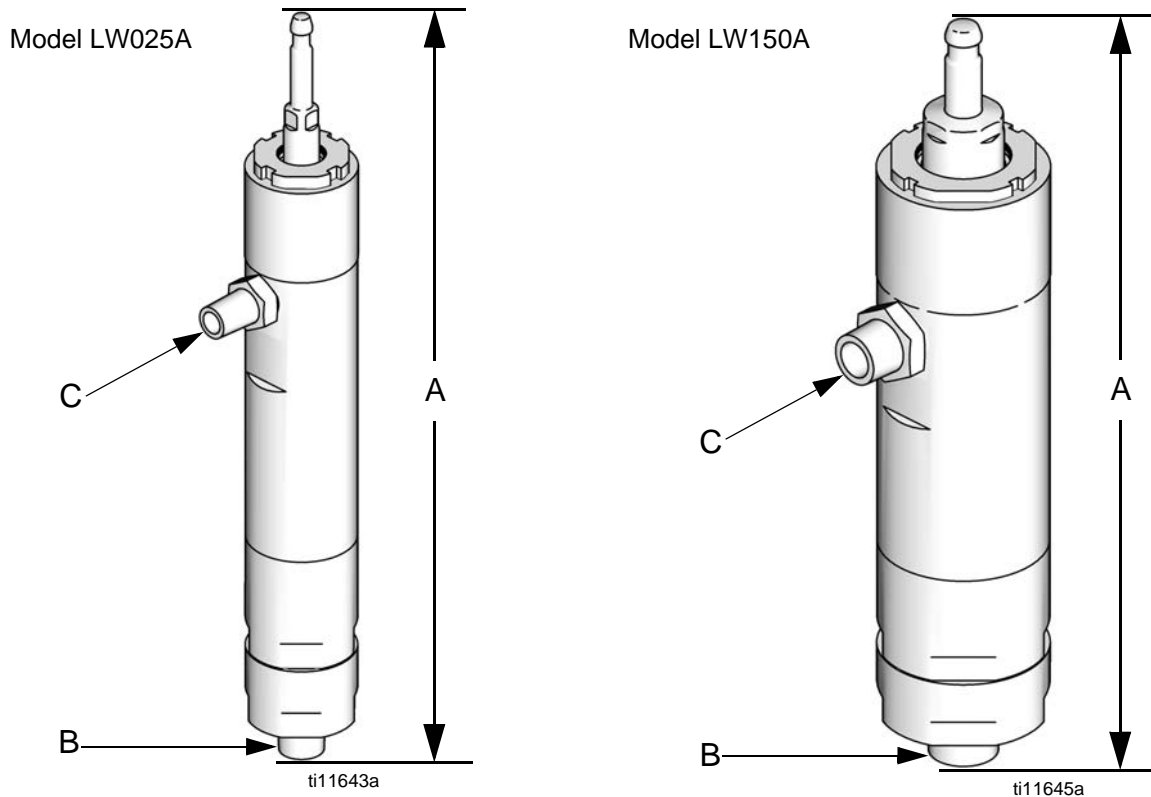

FIG. 8

Displacement Pump Dimensions

Displacement Pump	A (Height*) in. (mm)	B (Inlet Size) in. npt	C (Outlet Size) in. npt	Weight lbs (kg)
LW025A	14.9 (378)	1/2 in.	3/8 in.	9.0 (4.1)
LW050A	14.8 (376)	3/4 in.	3/8 in.	13.2 (6)
LW075A	15.4 (391)	3/4 in.	3/8 in.	15.3 (6.9)
LW100A	15.4 (391)	3/4 in.	3/8 in.	18.6 (8.4)
LW125A	15.6 (396)	1 in.	1/2 in.	21.2 (9.6)
LW150A	15.6 (396)	1 in.	3/4 in.	22.0 (10)

* Height measured at mid-stroke.

Technical Data

Maximum fluid working pressure

LW025A	3000 psi (20.7 MPa, 207 bar)
LW050A	4500 psi (33.1 MPa, 310 bar)
LW075A	4800 psi (33.1 MPa, 331 bar)
LW100A	3600 psi (24.8 MPa, 248 bar)
LW125A	2900 psi (20.0 MPa, 200 bar)
LW150A	2400 psi (16.5 MPa, 165 bar)

Maximum operating temperature 160°F (71°C)

Fluid inlet size

LW025A	1/2 in. npt
LW050A– LW100A	3/4 in. npt
LW125A–LW150A	1 in. npt

Fluid outlet size

LW025A–LW100A	3/8 in. npt
LW125A	1/2 in. npt
LW150A	3/4 in. npt

Stroke length 2.5 in.

Wetted parts stainless steel, tungsten carbide, UHMWPE, PTFE

Graco Standard Warranty

Graco warrants all equipment referenced in this document which is manufactured by Graco and bearing its name to be free from defects in material and workmanship on the date of sale to the original purchaser for use. With the exception of any special, extended, or limited warranty published by Graco, Graco will, for a period of twelve months from the date of sale, repair or replace any part of the equipment determined by Graco to be defective. This warranty applies only when the equipment is installed, operated and maintained in accordance with Graco's written recommendations.

This warranty does not cover, and Graco shall not be liable for general wear and tear, or any malfunction, damage or wear caused by faulty installation, misapplication, abrasion, corrosion, inadequate or improper maintenance, negligence, accident, tampering, or substitution of non-Graco component parts. Nor shall Graco be liable for malfunction, damage or wear caused by the incompatibility of Graco equipment with structures, accessories, equipment or materials not supplied by Graco, or the improper design, manufacture, installation, operation or maintenance of structures, accessories, equipment or materials not supplied by Graco.

This warranty is conditioned upon the prepaid return of the equipment claimed to be defective to an authorized Graco distributor for verification of the claimed defect. If the claimed defect is verified, Graco will repair or replace free of charge any defective parts. The equipment will be returned to the original purchaser transportation prepaid. If inspection of the equipment does not disclose any defect in material or workmanship, repairs will be made at a reasonable charge, which charges may include the costs of parts, labor, and transportation.

THIS WARRANTY IS EXCLUSIVE, AND IS IN LIEU OF ANY OTHER WARRANTIES, EXPRESS OR IMPLIED, INCLUDING BUT NOT LIMITED TO WARRANTY OF MERCHANTABILITY OR WARRANTY OF FITNESS FOR A PARTICULAR PURPOSE.

Graco's sole obligation and buyer's sole remedy for any breach of warranty shall be as set forth above. The buyer agrees that no other remedy (including, but not limited to, incidental or consequential damages for lost profits, lost sales, injury to person or property, or any other incidental or consequential loss) shall be available. Any action for breach of warranty must be brought within two (2) years of the date of sale.

GRACO MAKES NO WARRANTY, AND DISCLAIMS ALL IMPLIED WARRANTIES OF MERCHANTABILITY AND FITNESS FOR A PARTICULAR PURPOSE, IN CONNECTION WITH ACCESSORIES, EQUIPMENT, MATERIALS OR COMPONENTS SOLD BUT NOT MANUFACTURED BY GRACO. These items sold, but not manufactured by Graco (such as electric motors, switches, hose, etc.), are subject to the warranty, if any, of their manufacturer. Graco will provide purchaser with reasonable assistance in making any claim for breach of these warranties.

In no event will Graco be liable for indirect, incidental, special or consequential damages resulting from Graco supplying equipment hereunder, or the furnishing, performance, or use of any products or other goods sold hereto, whether due to a breach of contract, breach of warranty, the negligence of Graco, or otherwise.

FOR GRACO CANADA CUSTOMERS

The Parties acknowledge that they have required that the present document, as well as all documents, notices and legal proceedings entered into, given or instituted pursuant hereto or relating directly or indirectly hereto, be drawn up in English. Les parties reconnaissent avoir convenu que la rédaction du présente document sera en Anglais, ainsi que tous documents, avis et procédures judiciaires exécutés, donnés ou intentés, à la suite de ou en rapport, directement ou indirectement, avec les procédures concernées.

Graco Information

For the latest information about Graco products, visit www.graco.com.

For patent information, see www.graco.com/patents.

TO PLACE AN ORDER, contact your Graco distributor or call to identify the nearest distributor.

Phone: 612-623-6921 **or Toll Free:** 1-800-328-0211 **Fax:** 612-378-3505

*All written and visual data contained in this document reflects the latest product information available at the time of publication.
Graco reserves the right to make changes at any time without notice.*

Original instructions. *This manual contains English. MM 312792*

Graco Headquarters: Minneapolis

International Offices: Belgium, China, Japan, Korea

GRACO INC. AND SUBSIDIARIES • P.O. BOX 1441 • MINNEAPOLIS MN 55440-1441 • USA

Copyright 2008, Graco Inc. All Graco manufacturing locations are registered to ISO 9001.

www.graco.com

Revision H, November 2016