

# Remote Air Valve Conversion Kits

406827A

Husky® 1050 Diaphragm Pumps

ENG

**Kit 24D037, Aluminum**  
**Kit 24D038, Polypropylene**  
**Kit 24D039, Conductive Polypropylene**

Ref.	Description	Qty.
101	GASKET, air valve	1
102	SCREW, M6 x 25, Kit 24D037 (for use with metal housings)	4
103	NUT, Kits 24D038 and 24D039 (for use with plastic housings)	4
104	AIR VALVE, with restrictor	1
105	INSERT, remote pilot	2



**Important Safety Instructions**

Read all warnings and instructions in the Husky® 1050 Air-Operated Diaphragm Pump Repair/Parts manual. Save all instructions.

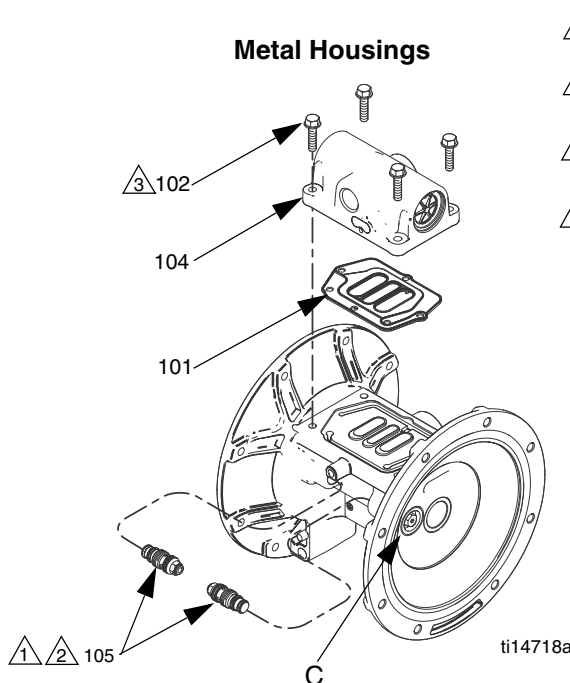

- 1 Apply lithium-based grease.
- 2 Torque to 20-25 in.-lb (2.3-2.8 N•m).
- 3 Torque in a crisscross pattern to 80 in.-lb (9.0 N•m).
- 4 Torque in a crisscross pattern to 55 in.-lb (6.2 N•m).

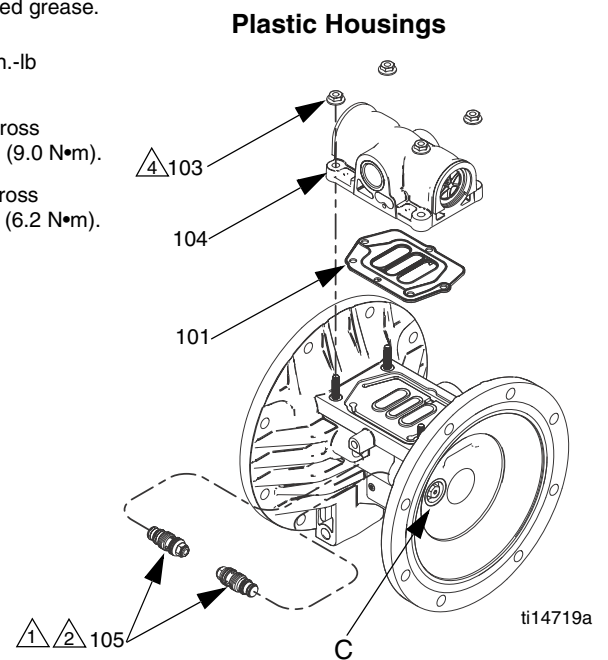

1. Remove pilot valves. Cartridges should remain in place. If removed, grease and reinstall the pilot valve cartridges (C) and o-rings. Screw in until seated.
2. Grease and install new pilot valve inserts (105). Torque to 20-25 in.-lb (2.3-2.8 N•m). Do not over-torque.

3. Remove air valve and gasket.
4. Align the new air valve gasket (101) on the center housing, then attach the new air valve (104). See **Torque Instructions** in the manual.