

ThermoLazer[®] 200/200TC/300TC and ThermoLazer ProMelt[™] Pavement Marking Systems

3A1321N

EN

For professional application of thermoplastic traffic marking compound materials (reflective beads applied simultaneously with screeding). For outdoor use only (not to be operated in rain or damp conditions)



IMPORTANT SAFETY INSTRUCTIONS

Read all warnings and instructions in this manual. Save these instructions.

Related Manuals:

Operation	3A1319
Repair	3A1320
Double Bead Box	3A0004
SmartDie[™] II	3A1738
FlexDie[™]	3A1738

ThermoLazer 200/200TC

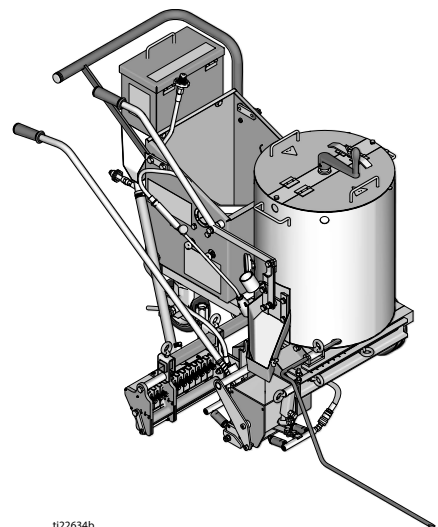

ti22634b

ThermoLazer ProMelt

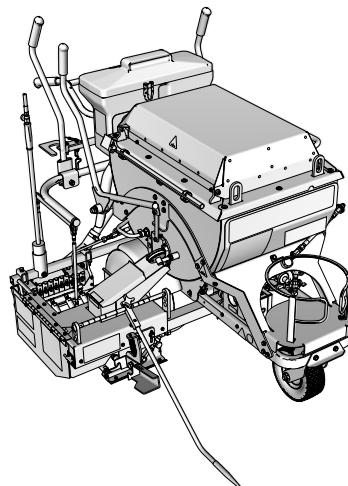

ti23073a

ThermoLazer 300TC

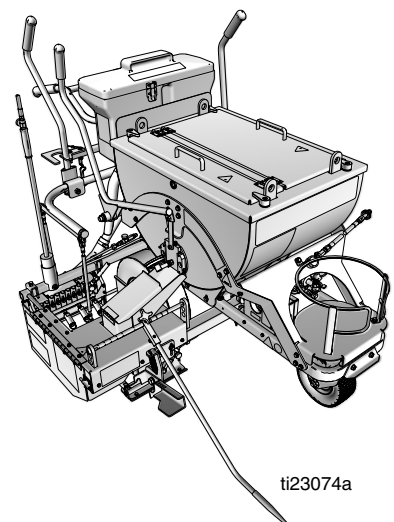

ti23074a

System Chart

SmartDie II used on ThermoLazer 300TC/ProMelt only.

SmartDie II Part No.	Smart Die Description
17A173	2 in. (5 cm)
24H431	3 in. (8 cm)
24H426	4 in. (10 cm)
17J250	4.75 in. (12 cm)
24H432	5 in. (13 cm)
24H427	6 in. (15 cm)
24H433	7 in. (18 cm)
24H428	8 in. (20 cm)
24H434	9 in. (22.5 cm)
24H429	10 in. (25 cm)
24H430	12 in. (30 cm)
‡17A174	16 in. (40 cm)
24H437	3-3-3 in. (8-8-8 cm)
24H435	4-3-4 in. (10-8-10 cm)
24H436	4-4-4 in. (10-10-10 cm)
24J785	4-6-4 in. (10-15-10 cm)
‡17A175	6-4-6 in. (15-10-15 cm)
‡17R378	5-5-5 in. (13-13-13 cm)

‡ Requires 16" (40 cm) Conversion Bead System Kit for 300TC/ProMelt Only.
 - 17B190 Kit, accy, 16" (40 cm) Single Drop Bead System

FlexDie used on ThermoLazer 200/200TC only.

FlexDie Part No.	FlexDie Description
16Y661	2 in. (5 cm)
16Y662	3 in. (8 cm)
16Y320	4 in. (10 cm)
16Y663	5 in. (12 cm)
16Y190	6 in. (15 cm)
16Y664	7 in. (18 cm)
16Y326	8 in. (20 cm)
16Y665	9 in. (22.5 cm)
16Y332	10 in. (25 cm)
16Y207	12 in. (30 cm)
16Y338	3-3-3 in. (8-8-8 cm)
16Y352	4-3-4 in. (10-8-10 cm)
16Y666	4-2-4 in. (10-5-10 cm)
16Y363	4-4-4 in. (10-10-10 cm)

Parts - ThermoLazer 200

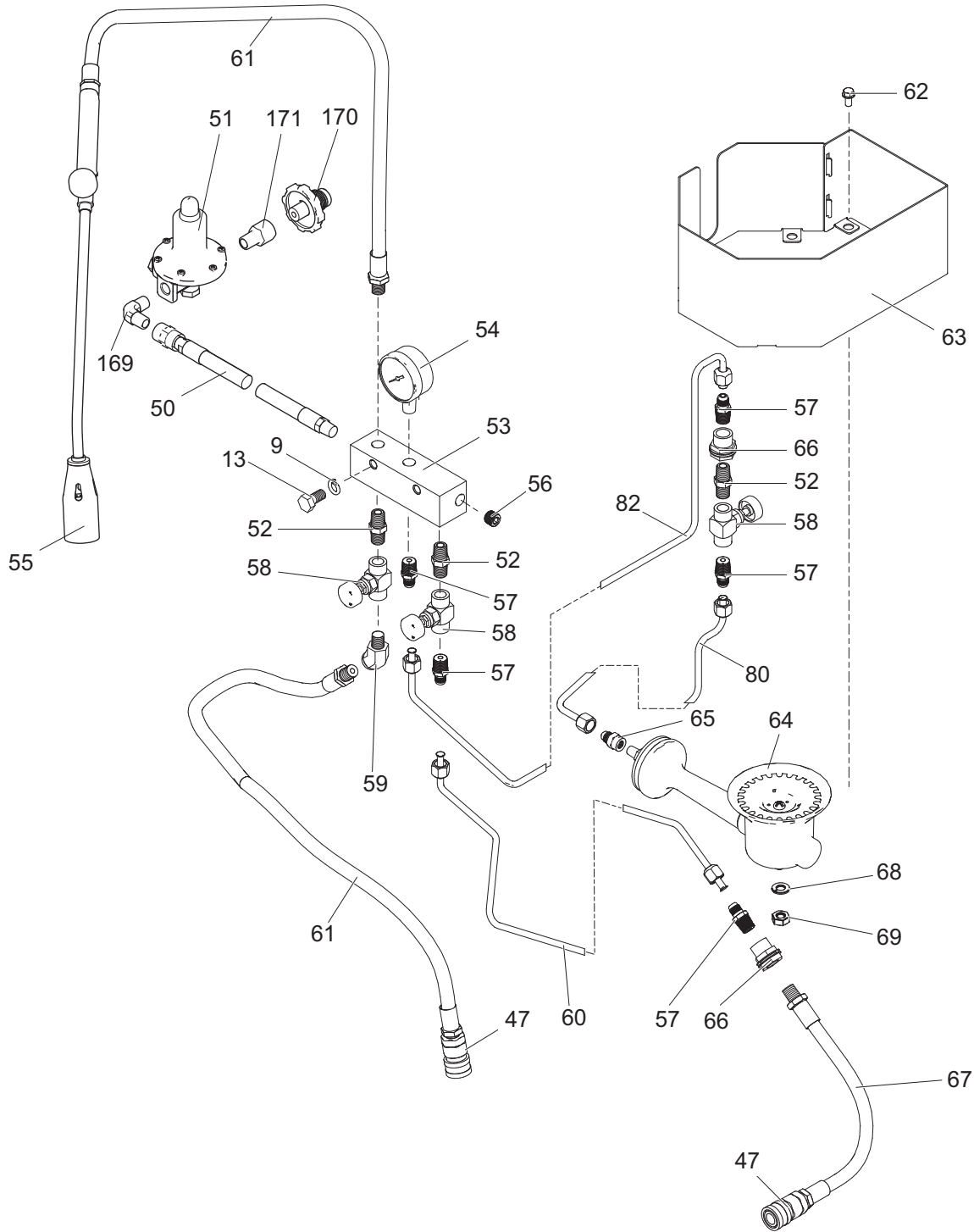

t123446a

Parts List - ThermoLazer 200

Ref.	Part No.	Description	Qty.
9	125632	WASHER, lock, spring, M10	19
13	105326	SCREW, cap, hex hd	14
47	16Y226	COUPLING, quick release, female	2
50*▲	123086	HOSE, rubber	1
51	17D903	KIT, repair, regulator (EU and US)	1
	17J090	KIT, repair, regulator (Asia Pacific)	1
52	867310	FITTING, nipple hx 14 x 1/4 npt	3
53	16Y180	MANIFOLD, gas	1
54	16Y229	GAUGE, pressure 0~0.1 MPA	1
55	16Y232	GUN, torch	1
56	557391	PLUG, dryseal, 1/4 nptf	1
57	16Y510	FITTING, flared, 1/4 pipe, adapter	5
58	16Y228	VALVE, needle, 1/4 f x 1/4 f	3
59	121283	FITTING, elbow, 45 deg street	1
60	17R364	TUBE, formed, die front	1
61	16Y250	HOSE, gas, die front	2
62	107257	SCREW, thd forming	6
63	16Y307	SHIELD, heat burner	1
64	16Y284	RING, burner, 4.25" D (includes 65)	1
65	16Y514	FITTING, flared, 1/8 pipe, adapter	
66	104641	FITTING, bulkhead	2
67	16Y249	HOSE, gas, die back	1
68	100016	WASHER, lock	1
69	100015	NUT, hex mscr	1
80	17R365	TUBE, formed, burner inlet	1
82	17R366	TUBE, formed, burner w/o control	1
169*▲	110249	ADAPTER, male, elbow, fitting	1
170▲	16Y506	CONNECTOR, gas tank	1
171	17B244	FITTING, adapter	1

* Included in Kit 17D903

▲ Included in Kit 17J090

Parts - ThermoLazer 200/200TC

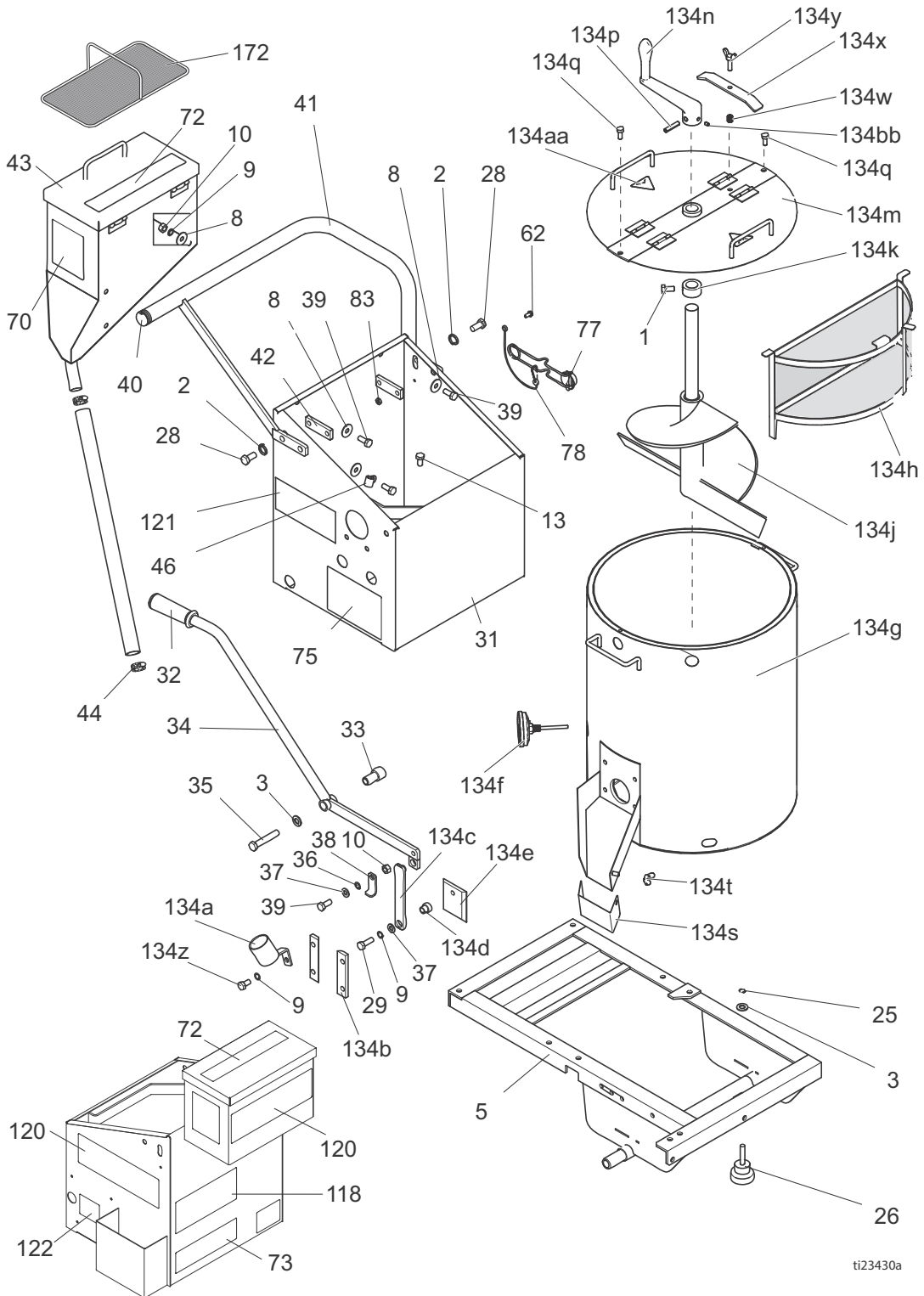

ti23430a

Parts List - ThermoLazer 200/200TC

Ref.	Part No.	Description	Qty.	Ref.	Part No.	Description	Qty.
					16Y835	RESERVOIR, reservoir assy TC, kits (200TC models)	1
1	105324	SCREW, cap, hex hd	2				
2	124704	WASHER, spring, metallic	8	134a	16Y063	HOLDER, torch holder	1
3	16Y269	WASHER, flat, M12	6	134b	16Y060	BAR, gate	2
5	16Y001	FRAME	1	134c	16Y061	LEVER, gate	1
7	16Y106	SPACER	2	134d	16Y062	BUSHING, sleeve	1
8	16Y266	WASHER, flat, M10	10	134e	16Y059	BAR, gate	1
9†◆	125632	WASHER, lock, spring, M10	19	134f	16Y246	GAUGE, thermometer	1
10	105327	NUT, hex	7	134g		RESERVOIR, base (16Y834)	1
13†◆	105326	SCREW, cap, hex head	14			RESERVOIR, base, TC (16Y835)	1
25	16Y271	RING, retaining, external, M12	2				
26	16Y152	SCREW, kettle lock	1	134h	16Y024	STRAINER, reservoir	1
28	16Y261	SCREW, cap, hex hd, M12 x 1.75 x 25	6	134j	16Y023	MIXER, mixer assy (16Y834)	1
					17E059	MIXER, agitator (16Y835)	1
29†◆	109487	SCREW, cap, head hd	3	134k	16Y054	SPACE, holder	1
31	16Y066	ENCLOSURE, propane cylinder	1	134m	16Y022	RESERVOIR, cover assy	1
				134n	16Y053	HANDLE, reservoir	1
32	123938	GRIP, handle	1	134p	16Y055	PIN, spring	1
33	16Y119	TUBE, pivot, handle	1	134q	17E050	SCREW, cap, hex hd	2
34	16Y114	HANDLE, gate valve	1	134s	16Y125	PLATE, splash plate	1
35	113708	SCREW, cap, hex hd	1	134t	16Y275	NUT, wing, M8	1
36	16Y258	WASHER, wave, M10	1	134w	117155	SPRING, compression	1
37†◆	16Y267	WASHER, plat, M10	5	134x	16Y240	LOCK, lid	1
38	16Y127	PLATE, cover	1	134y	16Y243	BOLT, wing	1
39	16Y268	BOLT, cap hex	1	134z	16Y268	BOLT, cap, hex	1
40	16Y126	CAPE, handle end	1	134aa▲	16D646	LABEL, 2 in., iso, hot surface	1
41	16Y147	HANDLE	1	134bb	124229	SCREW, set, socket head	1
42	16Y151	HOLDER, handle	2	172	17E092	STRAINER, beads box	1
43	16Y090	BOX, bead	1				
44	16Y230	HOSE, clamp	1				
45	17B554	HOSE, hose 1.00 ID x 1.26 O.D.	1				
46	16Y310	CLAMP, rubber hose, clamp	1				
62◆	107257	SCREW, thd forming	6				
70	16E335	LABEL, brand, Graco	2				
72▲	16A276	LABEL, ISO, symbols warning	1				
73▲	15Y966	LABEL, warning, fire and explosion	1				
75	16X636	Label, instruct, thermo. burner	1				
77	123186	TOOL, spark lighter	1				
78	121458	TIE, lanyard	1				
83	140045	NUT, hex, jam	2				
118▲	15Y964	LABEL, warning, kettle (200TC only)	1				
120	16X976	LABEL, brand, ThermoLazer 200	2				
	16X975	LABEL, brand, ThermoLazer 200	2				
121	16Y481	LABEL, brand, ThermoLazer 200, side	1				
	16Y480	LABEL, brand, ThermoLazer 200TC, side					
122	16X637	LABEL, instruction, thermo. burner (200 model only)	1				
134	16Y834	RESERVOIR, reservoir assy, kits (200 model)	1				

† Parts included in Kit 16Y834

◆ Parts included in Kit 16Y835

▲ Replacement Danger and Warning labels, tags, and cards are available at no cost.

Parts - ThermoLazer 200/200TC

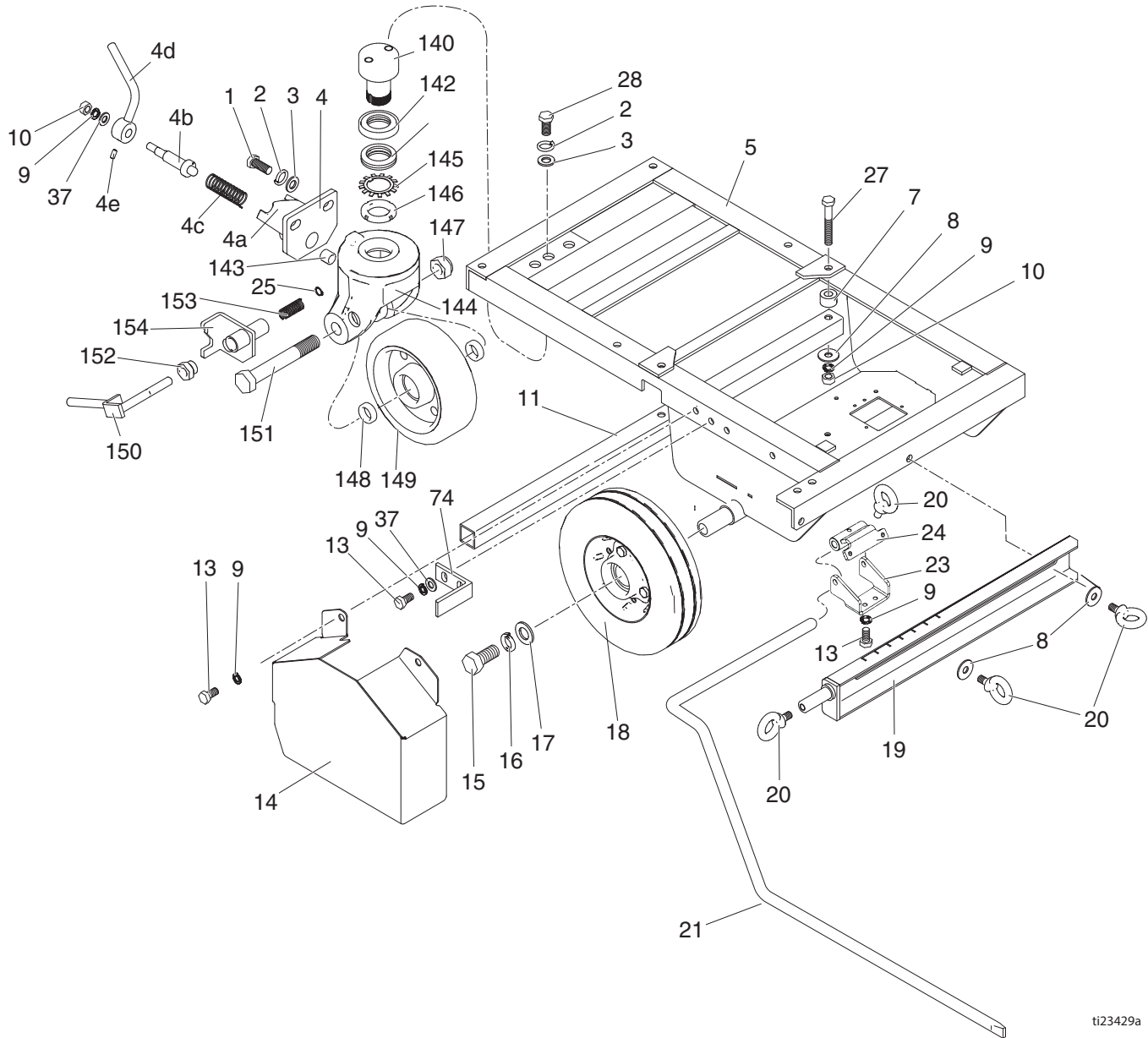

ti23429a

Parts List- ThermoLazer 200/200TC

Ref.	Part No.	Description	Qty.
1	105324	SCREW, cap, hex hd	2
2	124704	WASHER, spring, metallic	8
3	16Y269	WASHER, flat, M12	6
4	16Y140	HOLDER, rear wheel assy (includes 4a-4e, 9, 10, 37)	1
4a	16Y141	FRAME, rear wheel holder, mach	1
4b	16Y145	SHAFT, locker	1
4c	16Y210	SPRING, compression	1
4d	16Y146	LOCK, swing	1
4e	100664	SCREW, set, sch	1
5	16Y001	FRAME	1
7	16Y106	SPACER	2
8	16Y266	WASHER, flat, M10	10
9	125632	WASHER, lock, spring, M10	19
10	105327	NUT, hex	8
11	16Y084	BRACKET, dispenser holder	1
13	105326	SCREW, cap, hex hd	14
14	16Y086	COVER, wheel	1
15	16Y280	SCREW, cap, hex hd, M18 x 2.5 x 35	2
16	16Y279	WASHER, lock, M18	2
17	16Y278	WASHER, flat, M18	2
18	16Y085	WHEEL, front	2
19	16Y073	BRACKET, frame branch, die	1
20	16Y274	SCREW, ring screw, M10	3
21	17B469	ROD, indicator	1
23	17B468	BRACKET, mount, pointer	1
24	17B470	BRACKET, pointer	1
25	16Y271	RING, retaining, external, M12	2
27	16Y260	SCREW, cap, hex hd, M10 x 1.5 x 70	2
28	16Y261	SCREW, cap, hex hd, M12 x 1.75 x 25	6
37	16Y267	WASHER, plat, M10	5
39	16Y268	BOLT, M10X25	2
74	16Y548	BLADE, wheel	2
140	16Y132	ROTATOR, wheel	1
141	16Y134	BEARING, thrust ball bearing	2
142	16Y133	RING, thrust bearing	1
143	16Y137	BUSHING	1
144	16Y128	FRAME, rear wheel, machining	1
145	16Y135	RING, lock	1
146	16Y136	NUT, lock, rolling bearing	1
147	626426	NUT, hex, nylok	1
148	16Y139	SPACER	2
149	16Y138	WHEEL, rear	1
150	16Y214	LOCK, rod locker	1
151	16Y276	SCREW, cap, hex hd, M20 x 2.5 x 140	1
152	16Y218	NUT, retainer	1
153	16Y211	LOCK, wheel locker	1
154	16Y219	SPRING, compression	1
155	16Y128	WHEEL, rear, assy, (includes 25, 140,142, 144-154)	1

Parts - ThermoLazer 200TC

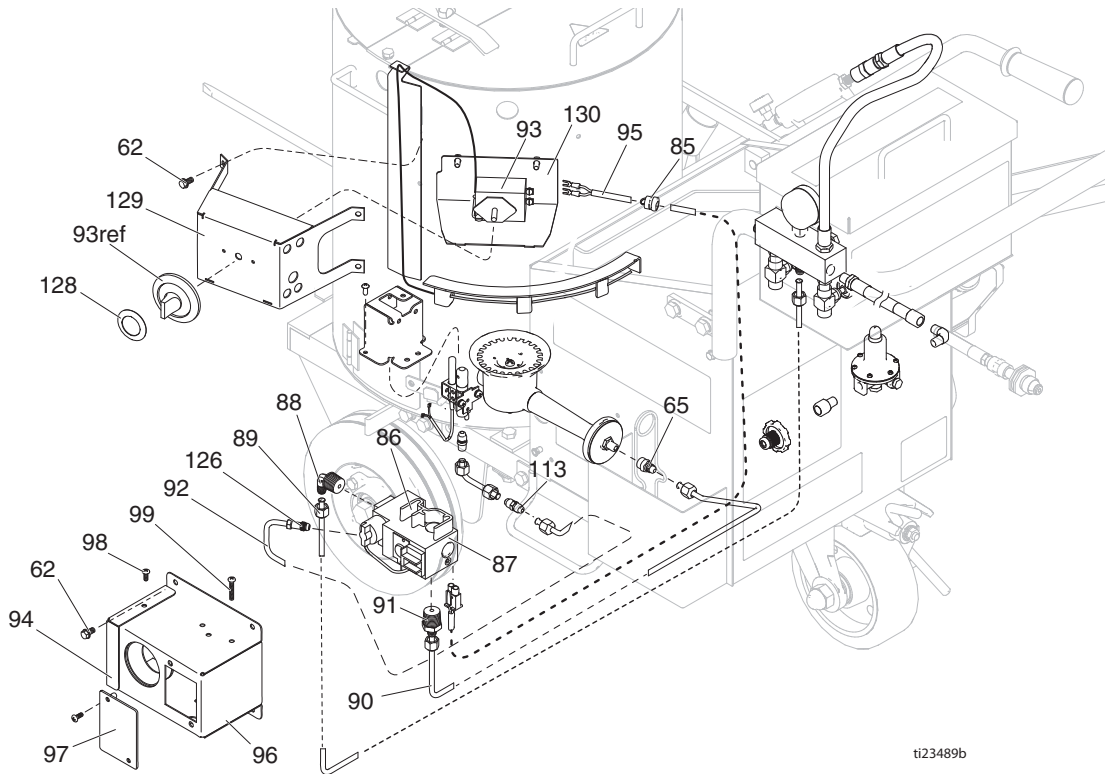
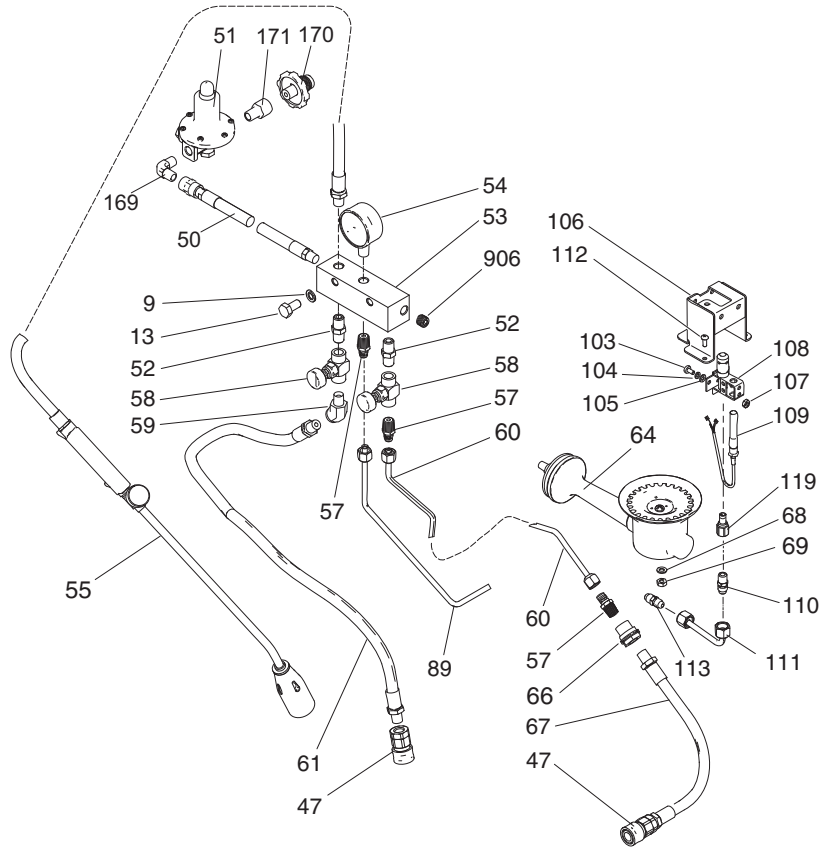

ti23489b

Parts List - ThermoLazer 200TC

Ref.	Part No.	Description	Qty.	Ref.	Part No.	Description	Qty.
9	125632	WASHER, lock, spring, M10	19	128	16A873	LABEL, temperature control	1
13	105326	SCREW, cap, hex hd	14	129	16Y308	BRACKET, mount, temp control	1
47	16Y226	COUPLING, quick release, female	2	130	16Y309	COVER, mount, temp control	1
50*▲	123086	HOSE, propane w/ polswivel adapter	1	131	16Y835	KIT, reservoir assy (includes 62, 85, 93, 95, 128-130)	1
51	17D903	KIT, repair, regulator (EU and US)	1	169*▲	110249	ADAPTER, male, elbow, 90°	1
	17J090	KIT, repair, regulator (Asia Pacific)	1	170▲	16Y506	CONNECTOR, gas tank	1
52	867310	FITTING, nipple hx 14 x 1/4 npt	3	171	17B244	FITTING, adapter	1
53	16Y180	MANIFOLD, gas	1				
54	16Y229	GAUGE, pressure 0~0.1 MPA	1				
55	16Y232	GUN, torch	1				
56	557391	PLUG, dryseal, 1/4 nptf	1				
57	16Y510	FITTING, flared, 1/4 pipe, adapter	3				
58	16Y228	VALVE, needle, 1/4 f x 1/4 f	2				
59	121283	FITTING, elbow, 45 deg street	1				
60	16Y285	TUBE, formed, die front	1				
61	16Y250	HOSE, gas, die front	2				
62	107257	SCREW, thd forming	6				
63	16Y307	SHIELD, heat burner	1				
64	16Y284	RING, burner, 4.25" D	1				
65	16Y514	FITTING, flared, 1/8 pipe, adapter	1				
66	104641	FITTING, bulkhead	2				
67	16Y249	HOSE, gas, die back	1				
68	100016	WASHER,lock	1				
69	100015	NUT, hex mscr	1				
85	16Y508	HARNESS, wire	1				
85a	17B245	HARNESS,wire, valve	1				
86	16A708	BLOCK, spacer, gas valve	1				
87	17B233	KIT, valve, gas, ProMelt (includes 88,91,92)	1				
88	16Y513	FITTING, flare, 1/2 pipe, 90 elbow	1				
89	16Y288	TUBE, formed, burner control in	1				
90	16Y289	TUBE, formed, burner, w/ control	1				
91	16Y511	FITTING, flared, 1/2 pipe, adapter	1				
92	17B234	KIT, pilot, tube (includes 126)	1				
93	17B232	KIT, repair, temp, control (includes 128)					
94	16Y304	COVER, gas valve	1				
95	119868	BUSHING, strain relief					
96	16Y300	BOX, gas valve, complete	1				
97	16C333	DOOR	1				
98	116610	SCREW, mach, phil, pan, #10	3				
99	111235	SCREW, mach, pnh	3				
103	110637	SCREW, mach, pan head	2				
104	100020	WASHER, lock	2				
105	116876	WASHER, flat	2				
106	16W410	BRACKET, mount, electrode	1				
107	100179	NUT, hex mscr	1				
108	24J574	KIT, repair, pilot, ProMelt	1				
109	122944	FITTING, thermopile	1				
110	123162	FITTING, flared, 1/8 pipe, adapter	1				
111	16J687	TUBE, formed, gas, pilot	1				
112	114984	SCREW, tapping, phillips pan hd	4				
113	123160	FITTING, flared, 1/4 tube, coupling	1				
119	125324	FITTING, inlet, pilot, ProMelt	1				
126	24C113	KIT, repair, fitting, ferrule	1				

* Included in Kit 17D903

▲ Included in Kit 17J090

Parts - Bead Dispenser

17B832 BOX, bead, 8" with 1" gates

16Y891 BOX, bead, 12" with 1" gates

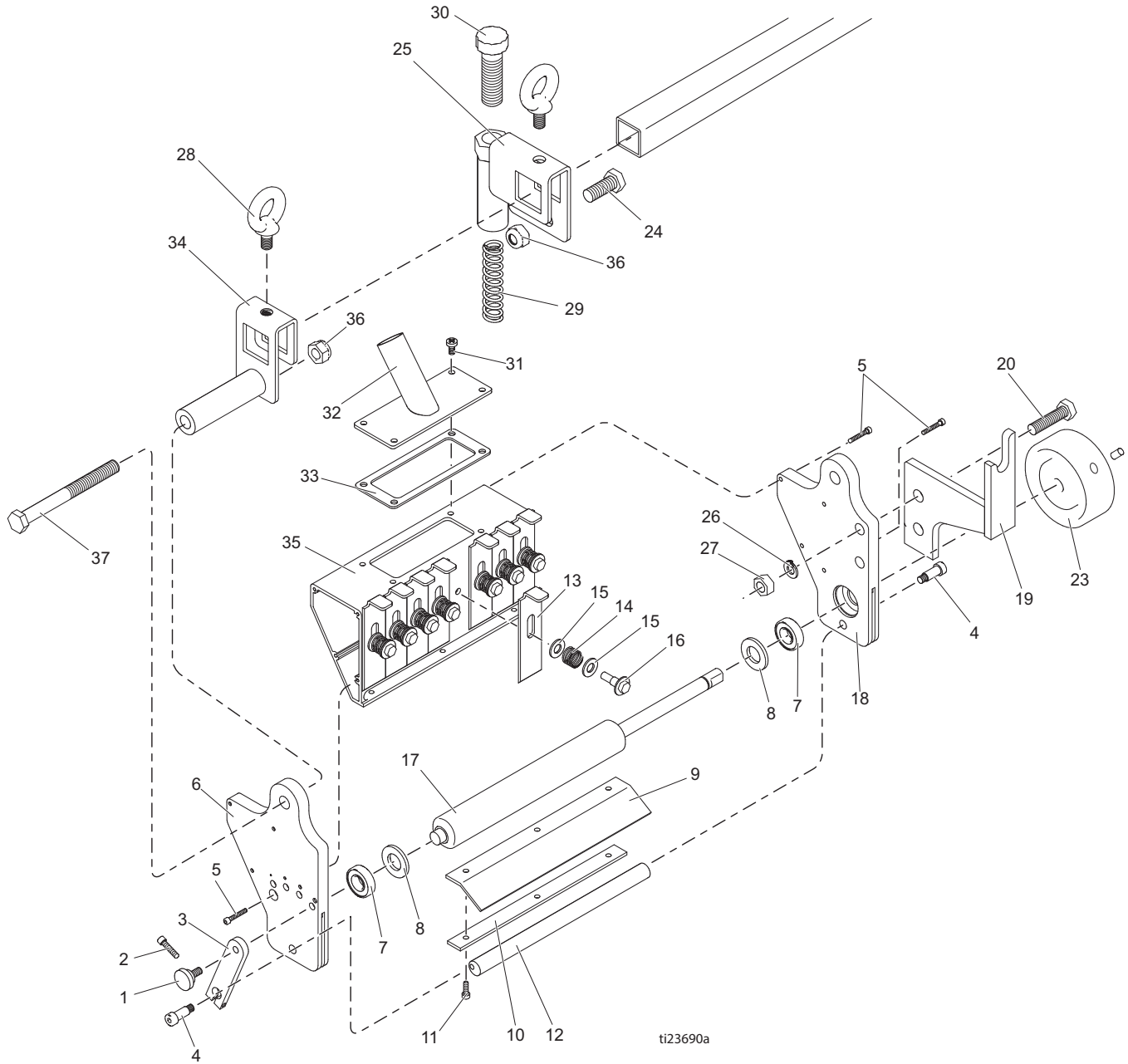

ti23690a

Parts - Bead Dispenser

Ref	Part	Description	Qty	Ref	Part	Description	Qty
1	123261	SCREW, thumb	1	18	16Y162	BRACKET, right, bead dispenser	1
2	295709	SCREW, cap, socket head	1	19	17D553	BRACKET, die, support	1
3	15X282	HANDLE, adjuster	1	20	122942	BOLT, M10 x 40 lg	2
4	123481	SCREW, shoulder, screw, 1/4-20	2	22	100664	SCREW, set, sch	1
5	110631	SCREW, socket, hd	8	23	15X765	WHEEL, drive, bead	1
6	16Y163	BRACKET, left, bead dispenser	1	24	105324	SCREW, cap, hex hd (16Y158)	2
7	123304	BEARING, double sealed	2			SCREW, cap, hex hd (16Y159)	1
8	114797	GASKET	2	25	16Y110	CLAMPE, bead box	1
9	16Y164	GATE, seal, 200 (16Y158)	1	26	125632	WASHER, lock, spring, M10	2
	15X274	GATE, poly (16Y159)	1	27	105327	NUT, hex	2
10	16Y165	GATE, clamp bar 200 (16Y158)	1	28	16Y274	SCREW, ring screw, M10	2
	15X275	GATE, bar (16Y159)	1	29	16Y113	SPRING, compress spring	1
11	112310	SCREW, cap, sch (16Y158)	3	30	16Y263	BOLT, machine bolt	1
		SCREW, cap, sch (16Y159)	4	31	106084	SCREW, mach, pnh	4
12	16Y166	SHAFT, adjuster, 200 (16Y158)	1	32	16Y169	MANIFOLD, cover	1
	15X281	ADJUSTER (16Y159)	1	33	16Y168	GASKET, cover	1
13	16U612	PLATE, slide, 1" (16Y158)	8	34	16Y108	BRACKET, pivot, bead box	1
		PLATE, slide, 1" (16Y159)	12			(16Y158)	
14	114708	SPRING, compression (16Y158)	8		16Y107	CLAMP, bead box (16Y159)	1
		SPRING, compression (16Y159)	12	35	16Y160	HOSING, dispenser 200 (16Y158)	1
15	104034	WASHER, plain (16Y158)	16		16Y172	HOUSING, dispenser 300	1
		WASHER, plain (16Y159)	24			(16Y159)	
16	119872	SCREW, shoulder (16Y158)	8	36	16Y270	NUT, nylon loc, M12, thin	2
		SCREW, shoulder (16Y159)	12	37	16Y262	SCREW, cap, hex hd, M12 x 1.75 x	1
17	17B363	SHAFT, knurled 200, 20 cm	1			120 (16Y159 only)	
		(16Y158)					
	17B362	SHAFT, knurled, 30 cm (16Y159)	1				

Parts - FlexDie Box

16Y661	2 in. (5 cm)
16Y662	3 in. (8 cm)
16Y320	4 in. (10 cm)
16Y663	5 in. (12 cm)
16Y190	6 in. (15 cm)
16Y664	7 in. (18 cm)
16Y326	8 in. (20 cm)
16Y665	9 in. (22.5 cm)
16Y332	10 in. (25 cm)
16Y207	12 in. (30 cm)

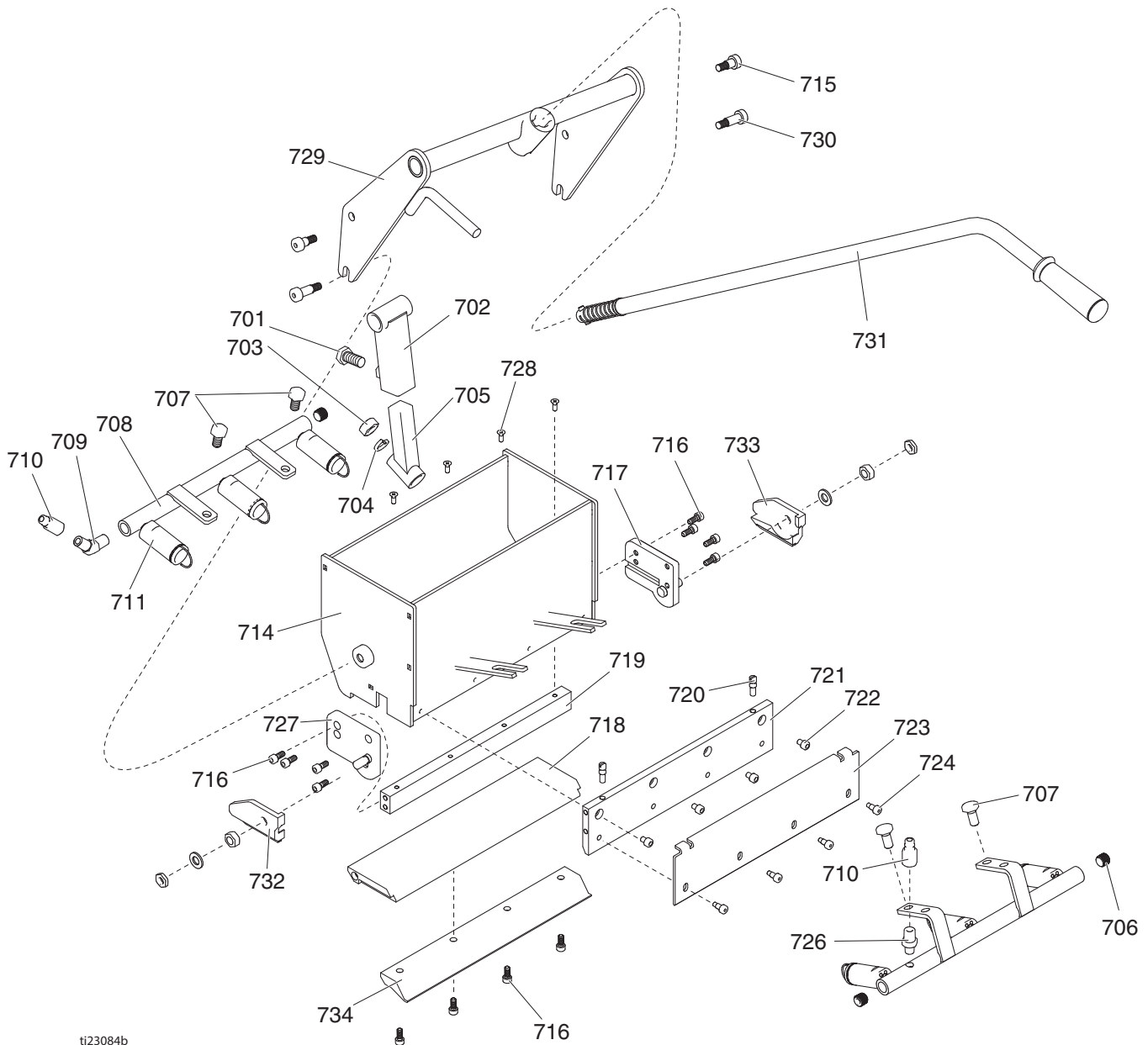

ti23084b

Parts List - FlexDie Box

Ref.	Part	Description	Qty.	Ref.	Part	Description	Qty.
701	16Y261	SCREW, cap, hex hd, M12 X 1.75 X 25	1		17D551	BAR, shear, stop, 10 in. (16Y332)	1
702	16Y077	CONNECTOR, die pivot	1		17D552	BAR, shear, stop, 12 in. (16Y207)	1
703	107539	NUT, hex	1	722	110501	SCREW, cap, sch (M6 X 8) (16Y661)	3
704	124704	WASHER, spring, metallic	1			SCREW, cap, sch (M6 X 8) (16Y662)	2
705	16Y081	HOLDER, die holder	1			SCREW, cap, sch (M6 X 8) (16Y320)	2
706	557391	PLUG, dryseal 1/4 NPTF	3			SCREW, cap, sch (M6 X 8) (16Y663)	3
707	105326	SCREW, cap hex hd	4			SCREW, cap, sch (M6 X 8) (16Y190)	3
708	16Y237	TUBE, burner front, 2 in. (16Y661)	1			SCREW, cap, sch (M6 X 8) (16Y664)	3
		TUBE, burner front, 3 in. (16Y662)	1			SCREW, cap, sch (M6 X 8) (16Y326)	3
	16Y252	TUBE, burner front, 4 in. (16Y320)	1			SCREW, cap, sch (M6 X 8) (16Y665)	4
	16Y681	TUBE, burner front, 5 in. (16Y663)	1			SCREW, cap, sch (M6 X 8) (16Y332)	4
	16Y237	TUBE, burner front, 6 in. (16Y190)	1			SCREW, cap, sch (M6 X 8) (16Y207)	4
	16Y715	TUBE, burner front, 7 in. (16Y664)	1	723	17A188	PLATE, screed, adjustable, 2 in., (16Y661)	1
	16Y689	TUBE, burner front, 8 in (16Y326)	1		17D526	PLATE, screed, adjustable, 3 in. (16Y662)	1
	16Y755	TUBE, burner front, 9 in. (16Y665)	1		17D527	PLATE, screed, adjustable, 4 in. (16Y320)	1
	16Y486	TUBE, burner front, 10 in. (16Y332)	1		17D528	PLATE, screed, adjustable, 5 in. (16Y663)	1
	16Y244	TUBE, burner front, 12 in. (16Y207)	1		17D529	PLATE, screed, adjustable, 6 in. (16Y190)	1
709	17D594	FITTING, elbow 45, 1/4 npt	1		17D530	PLATE, screed, adjustable, 7 in. (16Y664)	1
710	16Y225	COUPLING, quick release, male	2		17D531	PLATE, screed, adjustable, 8 in (16Y326)	1
711	17B231	KIT, repair, torch head, die (16Y661)	4		17D532	PLATE, screed, adjustable, 9 in. (16Y665)	1
		KIT, repair, torch head, die (16Y662)	1		17D533	PLATE, screed, adjustable, 10 in. (16Y332)	1
		KIT, repair, torch head, die (16Y320)	4		17D534	PLATE, screed, adjustable, 12 in. (16Y207)	1
		KIT, repair, torch head, die (16Y663)	4	724	17D772	SCREW, shoulder, socket head M5 (16Y661)	3
		KIT, repair, torch head, die (16Y190)	4			SCREW, shoulder, socket head M5 (16Y662)	2
		KIT, repair, torch head, die (16Y664)	4			SCREW, shoulder, socket head M5 (16Y320)	2
		KIT, repair, torch head, die (16Y326)	4			SCREW, shoulder, socket head M5 (16Y663)	3
		KIT, repair, torch head, die (16Y665)	6			SCREW, shoulder, socket head M5 (16Y190)	3
		KIT, repair, torch head, die (16Y332)	6			SCREW, shoulder, socket head M5 (16Y664)	3
		KIT, repair, torch head, die (16Y207)	6			SCREW, shoulder, socket head M5 (16Y326)	3
714		BOX, die, weldment, 2 in. (16Y661)	1			SCREW, shoulder, socket head M5 (16Y665)	4
		BOX, die, weldment, 3 in. (16Y662)	1			SCREW, shoulder, socket head M5 (16Y332)	4
		BOX, die, weldment, 4 in. (16Y320)	1			SCREW, shoulder, socket head M5(16Y207)	4
		BOX, die, weldment, 5 in. (16Y663)	1	725	16Y222	TUBE, back burner, 2 in., (16Y661)	1
		BOX, die, weldment, 6 in. (16Y190)	1		17D517	TUBE, back burner, 3 in., (16Y662)	1
		BOX, die, weldment, 7 in. (16Y664)	1		17D518	TUBE, back burner, 4 in. (16Y320)	1
		BOX, die, weldment, 8 in (16Y326)	1			TUBE, back burner, 5 in. (16Y663)	1
		BOX, die, weldment, 9 in. (16Y665)	1		17D520	TUBE, back burner, 6 in. (16Y190)	1
		BOX, die, weldment, 10 in. (16Y332)	1			TUBE, back burner, 7 in. (16Y664)	1
		BOX, die, weldment, 12 in. (16Y207)	1		17D522	TUBE, back burner, 8 in. (16Y326)	1
715	125028	SCREW, shoulder, socket head M8	2		17D523	TUBE, back burner, 9 in. (16Y665)	1
716	121518	SCREW, cap, sch (16Y661)	8		17D524	TUBE, back burner, 10 in. (16Y332)	1
		SCREW, cap, sch (16Y662)	10		17D525	TUBE, back burner, 12 in. (16Y207)	1
		SCREW, cap, sch (16Y320)	10	726	16Y235	FITTING, nipple, 1/4 NPT to 1/8 NPT	1
		SCREW, cap, sch (16Y663)	11	727	17D497	PLATE, pivot, right	1
		SCREW, cap, sch (16Y190)	11	728	123340	SCREW, mach, flat head, undercut (16Y661)	3
		SCREW, cap, sch (16Y664)	11			SCREW, mach, flat head, undercut (16Y662)	2
		SCREW, cap, sch (16Y326)	11			SCREW, mach, flat head, undercut (16Y320)	2
		SCREW, cap, sch (16Y665)	12			SCREW, mach, flat head, undercut (16Y663)	3
		SCREW, cap, sch (16Y332)	12			SCREW, mach, flat head, undercut (16Y190)	3
		SCREW, cap, sch (16Y207)	12			SCREW, mach, flat head, undercut (16Y664)	3
717	17D499	PLATE, pivot, left	1			SCREW, mach, flat head, undercut (16Y326)	3
718	17A184	BAR, shear, 2 in., (16Y661)	1			SCREW, mach, flat head, undercut (16Y665)	4
	17D535	BAR, shear, 3 in., (16Y662)	1			SCREW, mach, flat head, undercut (16Y332)	4
	17D536	BAR, shear, 4in., (16Y320)	1			SCREW, mach, flat head, undercut (16Y207)	4
	17D537	BAR, shear, 5 in. (16Y663)	1	729	16Y198	YOKE, weldment, 2 in. (16Y661)	1
	17D538	BAR, shear, 6 in. (16Y190)	1		16Y702	YOKE, weldment, 3 in. (16Y662)	1
	17D539	BAR, shear, 7 in. (16Y664)	1		16Y324	YOKE, weldment, 4 in. (16Y320)	1
	17D540	BAR, shear, 8 in (16Y326)	1		16Y673	YOKE, weldment, 5 in. (16Y663)	1
	17D541	BAR, shear, 9 in. (16Y665)	1		16Y198	YOKE, weldment, 6 in. (16Y190)	1
	17D542	BAR, shear, 10 in. (16Y332)	1		16Y713	YOKE, weldment, 7 in. (16Y664)	1
	17D543	BAR, shear, 12 in (16Y207)	1		16Y330	YOKE, weldment, 8 in. (16Y326)	1
719	16G996	BAR, support, 2 in., (16Y661)	1		16Y753	YOKE, weldment , 9 in. (16Y665)	1
	16H001	BAR, support, 3 in.,(16Y662)	1		16Y336	YOKE, weldment, 10 in. (16Y332)	1
	16G995	BAR, support, 3 in., (16Y320)	1		16Y206	YOKE, weldment, 12 in. (16Y207)	1
	16H006	BAR, support, 5 in. (16Y663)	1	730	125027	SCREW, shoulder, socket head M8	2
	16G996	BAR, support, 6 in. (16Y190)	1	731	16Y205	HANDLE, die handle, assy	1
	16H007	BAR, support, 7 in. (16Y664)	1	732	17D502	FLOAT RUNNER, right	1
	16G997	BAR, support, 8 in (16Y326)	1	733	17D504	FLOAT RUNNER, left	1
	16H008	BAR, support, 9 in. (16Y665)	1	734	17D508	BAR, shear, 3 in., (16Y662)	1
	16G998	BAR, support, 10 in. (16Y332)	1		17D509	BAR, shear, 4 in., (16Y320)	1
	16G999	BAR, support, 12 in. (16Y207)	1		17D510	BAR, shear, 5 in., (16Y663)	1
720	16H044	SCREW, adjustment, screed	2		17D511	BAR, shear, 6 in., (16Y190)	1
721	16H025	BAR, shear, stop, 2 in, (16Y661)	1		17D512	BAR, shear, 7 in., (16Y664)	1
	17D544	BAR, shear, stop, 3 in., (16Y662)	1		17D513	BAR, shear, 8 in., (16Y326)	1
	17D545	BAR, shear, stop, 4 in. (16Y320)	1		17D514	BAR, shear, 9 in., (16Y665)	1
	17D546	BAR, shear, stop, 5 in. (16Y663)	1		17D515	BAR, shear, 10 in., (16Y332)	1
	17D547	BAR, shear, stop, 6 in. (16Y190)	1		17D516	BAR, shear, 12 in., (16Y207)	1
	17D548	BAR, shear, stop, 7 in. (16Y664)	1	735	17D593	NUT, thin nut, M10	2
	17D549	BAR, shear, stop, 8 in (16Y326)	1	736	105327	NUT	2
	17D550	BAR, shear, stop, 9 in. (16Y665)	1	737	16Y267	WASHER	2

Parts - Double Line FlexDie Box

- 16Y338 3-3-3 in. (8-8-8 cm)
- 16Y352 4-3-4 in. (10-8-10 cm)
- 16Y666 4-2-4 in. (10-5-10 cm)
- 16Y363 4-4-4 in. (10-10-10 cm)

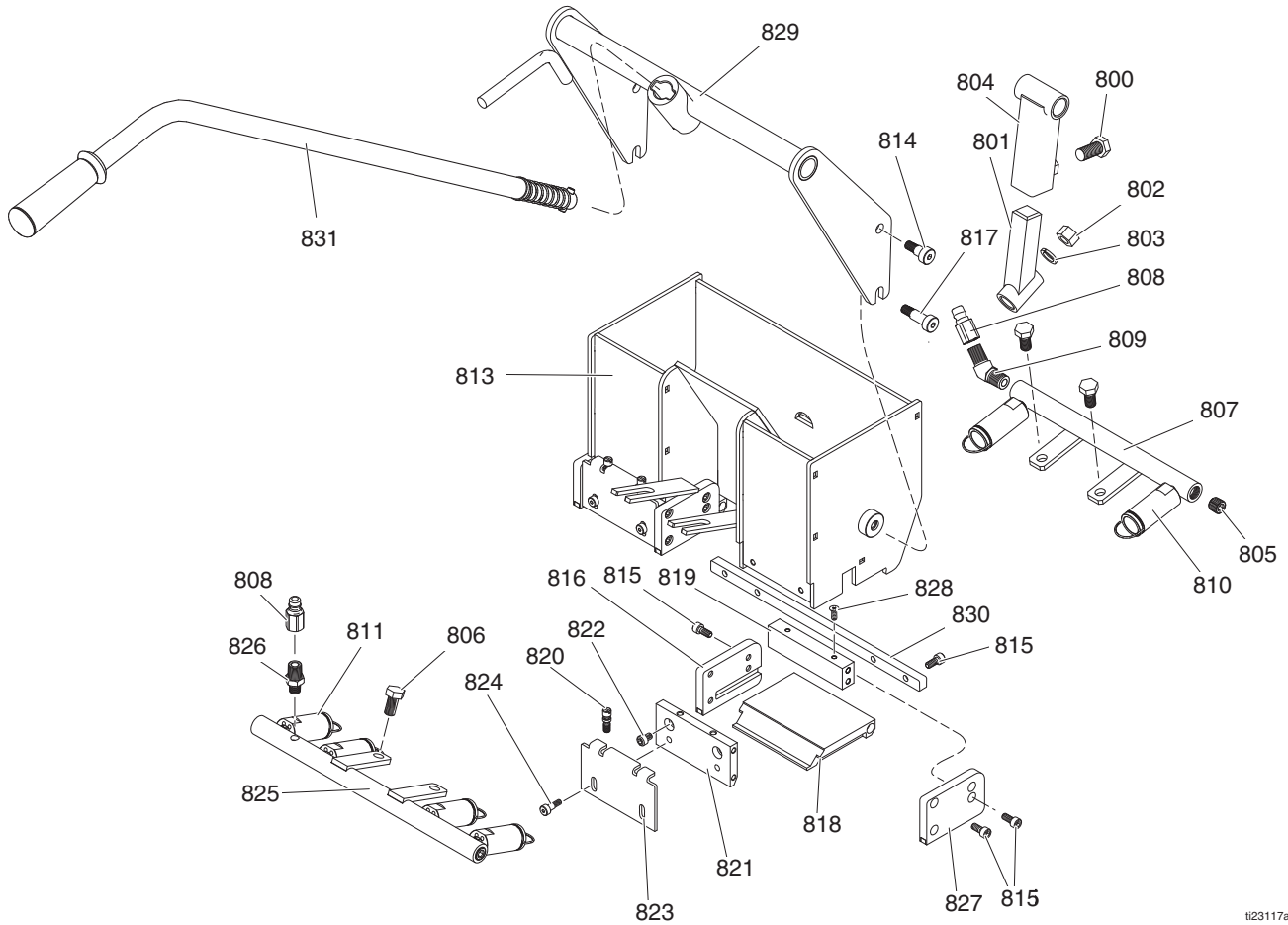

ti23117a

Parts List - Double Line FlexDie Box

Ref.	Part	Description	Qty.	Ref.	Part	Description	Qty.
800	16Y261	SCREW, cap, hex hd, M12 x 1.75 x 25	1	830	16H162	GUIDE, bar, shear, double, 3-3-3 (16Y338)	1
801	16Y081	HOLDER, die holder	1				
802	107539	NUT, hex	1	16H189	GUIDE, bar, shear, double, 4-3-4 (16Y352)	1	
803	124704	WASHER, spring, metallic	1				
804	16Y077	CONNECT, die pivot	1	16Y805	GUIDE, bar, shear, double, 4-2-4 (16Y666)	1	
805	557391	PLUG, dryseal, 1/4 NPTF	3				
806	105326	SCREW, cap hex hd	4	16H161	GUIDE, bar, shear, double, 4-4-4 (16Y363)	1	
807	16Y351	TUBE, burner front, 3-3-3 (16Y338)	1	831	16Y205	HANDLE, die handle, assy	1
	16Y361	TUBE, burner fron,4-3-4 (16Y352, 16Y666)	1				
	16Y371	TUBE, burner front, 4-4-4 (16Y363)	1				
808	16Y225	COUPLING, quick release, male	2				
809	17D594	FITTING, nipple hx 1/4 x 1/4 npt	1				
810	17B231	KIT, repair, torch head, die (model 16Y338)	4				
		KIT, repair, torch head, die (model 16Y352)	6				
		KIT, repair, torch head, die (model 16Y666)	6				
		KIT, repair, torch head, die (model 16Y363)	6				
813	16Y339	DIE, box weldent, 3-3-3 (16Y338)	1				
	16Y353	DIE, box weldent, 4-3-4 (16Y352)	1				
	16Y800	DIE, box weldent, 4-2-4 (16Y666)	1				
	16Y364	DIE, box weldent, 4-4-4 (16Y363)	1				
814	125028	SCREW, shoulder, socket head M8	2				
815	121518	SCREW, cap, sch	20				
816	24H580	PLATE, die runner, proscreed, left	2				
817	125027	SCREW, shoulder, socket head M8	2				
818	16H160	BAR, shear, die, double 3 in. (16Y338)	2				
	16H159	BAR, shear, die, double, 4 in. (16Y352, 16Y666, 16Y363)	2				
819	16H001	BAR, support (16Y338)	2				
	16G995	BAR, support (16Y352)	2				
	16G995	BAR, support (16Y666)	2				
	16H159	BAR, support (16Y363)	2				
820	16H044	SCREW, adjustment, screed	4				
821	16H029	BAR, shear, stop (16Y338)	2				
	16H024	BAR, shear, stop (16Y352, 16Y666, 16Y363)	2				
822	110501	SCREW, cap, sch (M6 x 8)	4				
823	16H033	PLATE, screed, adjustable, 3 in. (16Y338)	2				
	16H034	PLATE, sreed, adjustable, 4 in. (16Y352, 16Y666, 16Y363)	2				
824	125029	SCREW, shoulder, socket head, M5	4				
825	16Y347	TUBE, burner back, 3-3-3 (16Y338)	1				
	16Y358	TUBE, burner back, 4-3-4 (16Y352)	1				
	16Y806	TUBE, burner back, 4-2-4 (16Y666)	1				
	16Y368	TUBE, burner back, 4-4-4 (16Y363)	1				
826	16Y235	FITTING, nipple 1/4 npt to 1/8 npt	1				
827	24H581	PLATE, die runner, proscreed, right	2				
828	123340	SCREW, mach, flat head, undercut	4				
829	16Y753	YOKE, weldment, 3-3-3 (16Y338)	1				
	16Y355	YOKE, weldment, 4-3-4 (16Y352)	1				
	16Y336	YOKE, weldment, 4-2-4 (16Y666)	1				
	16Y206	YOKE, weldment, 4-4-4 (16Y363)	1				

Parts - ThermoLazer 300TC (Models 24H622, 24H625)

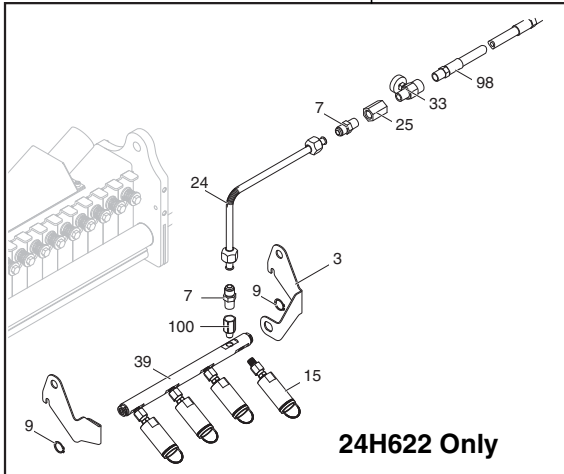
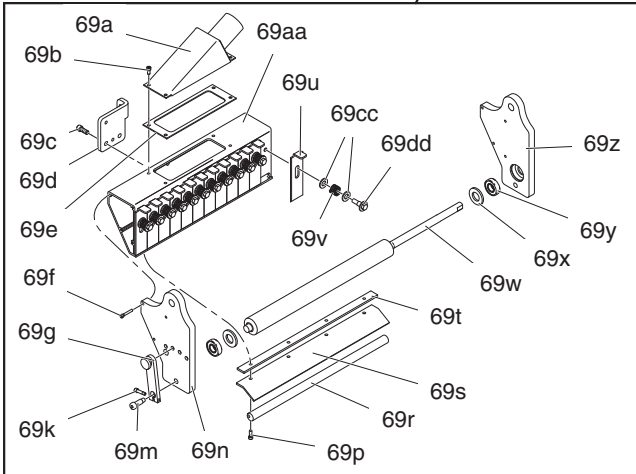
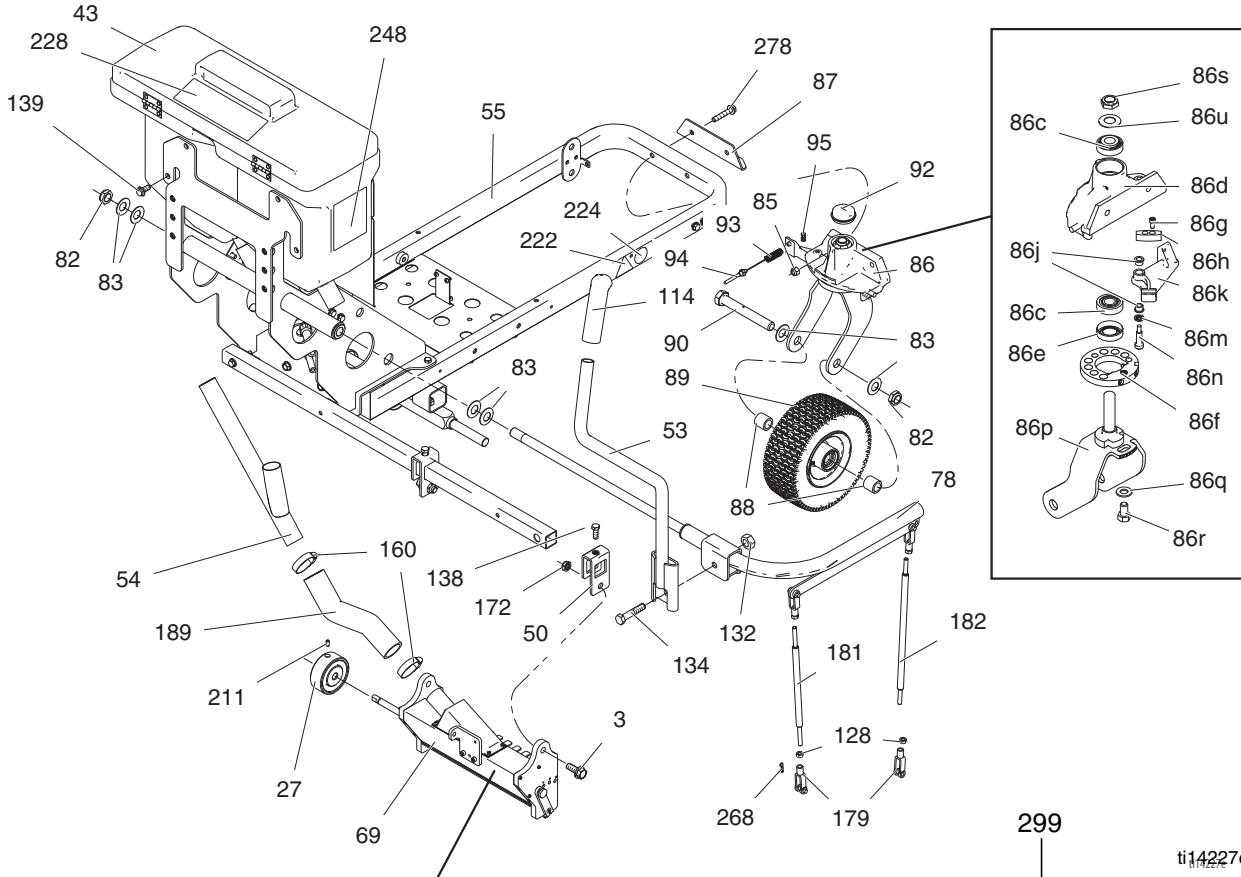

ti14227e

Parts List - ThermoLazer 300TC (Models 24H622, 24H625)

Ref.	Part	Description	Qty.	Ref.	Part	Description	Qty.
2	24J570	KIT, repair, torch head, die (includes 67) 24H622 24H625	7 3	86q	113962	WASHER, hardened, SAE	1
3	111195	SCREW, cap, flng HD	2	86r	114681	SCREW, cap, hex HD	1
27	15X765	WHEEL, drive, bead	1	86s	112405	NUT, lock	1
33	125064	VALVE, needle, gas, 1/4 npt	2	86u	112825	SPRING, belleville	2
39	24J578	KIT, repair, manifold, rear	1	87	240991	BRACKET, caster, front	1
43	24J865	KIT, replacement, bead hopper (includes 228, 248, 264)	1	88	193658	NUT, seal	2
50	257399	CLAMP, beadbox	2	89	114549	WHEEL, pneumatic	1
53	257455	HANDLE, lift, die/bead dispenser	1	90	113471	SCREW, cap, hex HD	1
54	257617	CONNECTOR, bead box hose	1	92	114648	CAP, dust	3
55	24J586	KIT, repair, frame (includes 222, 224)	1	93	114682	SPRING, compression	1
69	24R144	BOX, 12", with 1" gages	1	94	241445	KIT, cable	1
69a	257378	MANIFOLD, assembly	1	95	114802	STOP, wire	1
69b	112788	SCREW, cap, sockethead	4	98	16Y249	HOSE, torch, rear	1
69c	121112	SCREW, cap, sockethead	2	100	159840	ADAPTER	1
69d	16U614	BRACKET, beadbox, linkage	1	104	16H192	BRACKET, support, manifold, rear, left	1
69e	16A243	GASKET, foam	1	109	16H107	BRACKET, support, manifold, rear, right	1
69f	110631	SCREW, sockethead	8	112	113444	FITTING, elbow street, 45dx 1/4 npt	1
69g	24J866	HANDLE, adjuster, bead	1	114	114659	GRIP, handle	5
69k	295709	SCREW, cap, sockethead	1	115	101550	SCREW, cap, sch	4
69m	123481	SCREW, shoulder, screw, 1/4-20	2	128	100187	NUT	4
69n	16H292	BRACKET, right, bead dispenser	1	132	801020	NUT, lock	1
69p	112310	SCREW, cap, sch	4	134	114766	BOLT, cap hex head	1
69r	15X281	ADJUSTER	1	138	111145	KNOB, pronged	1
69s	15X274	GATE, poly	1	139	111192	SCREW, cap flang HD	26
69t	15X275	GATE, bar	1	151	118484	FITTING, connector	4
69u	16U612	PLATE, slide, 1"	12	160	116789	CLAMP, hose	6
69v	114708	SPRING, compression	12	172	119547	NUT, hex, lock, nylon, thin	2
69w	24C672	SHAFT, bead assembly kit	1	179	15V415	CLEVIS	4
69x	114797	GASKET	2	181	16A041	SHAFT, threaded	1
69y	123304	BEARING, double sealed	2	182	16H291	SHAFT, threaded	1
69z	16H293	BRACKET, left, bead dispenser	1	189	16A100	HOSE, bead	3
69aa	16U613	HOUSING, dispenser, 12", 12 holes	1	211	100664	SCREW, set, sch	1
69cc	104034	WASHER, plain	24	222▲	16A274	LABEL, ISO, explosion	1
69dd	119872	SCREW, shoulder	12	224	15Y963	LABEL, kettle burners, lighting	1
75	113958	RING, retaining, external	3	228▲	16A276	LABEL, ISO symbols warn & instru	1
78	15W873	ARM, die/bead dispenser	1	248	16E335	LABEL, brand, Graco	2
82	112405	NUT, lock	6	264▲	15Y966	LABEL, fire and explosion	1
83	112825	SPRING, belleville	10	268	120592	PIN, cotter, hairpin	3
85	101566	NUT, lock	12	270	16F660	SHIELD, heat, rear, Promelt	1
86	24H246	CASTER, promelt, blue	1	278	114982	SCREW, cap, flng HD	11
86c	113485	BEARING, cup/cone	2	299	24H619	KIT, accessory, rear torch (includes 2, 98, 151, 33, 115, 104, 70, 60, 67, 109, 75, 39, 100, 112, 372, 373)	1
86d	15G952	CASTER, machine	1	372	113093	CONNECTOR, pipe	1
86e	113484	SEAL, grease	1	373	16Y844	TUBE, formed, gas	1
86f	17H486	DISK, adjuster	1	374	16Y885	KIT, rear die hose (includes 33, 98, 100, 151, 373)	1
86g	110754	SCREW, cap, sch	2	▲ Replacement Danger and Warning labels, tags, and cards are available at no cost.			
86h	193662	STOP, wedge	1				
86j	114548	BEARING, bronze	2				
86k	193528	ARM, detent	1				
86m	15J603	SPACER, round, .625 in.	1				
86n	120476	BOLT, shoulder, 5/16	1				
86p	17H485	SHAFT, fork	1				

Parts - ThermoLazer 300TC (Models 24H622, 24H625)

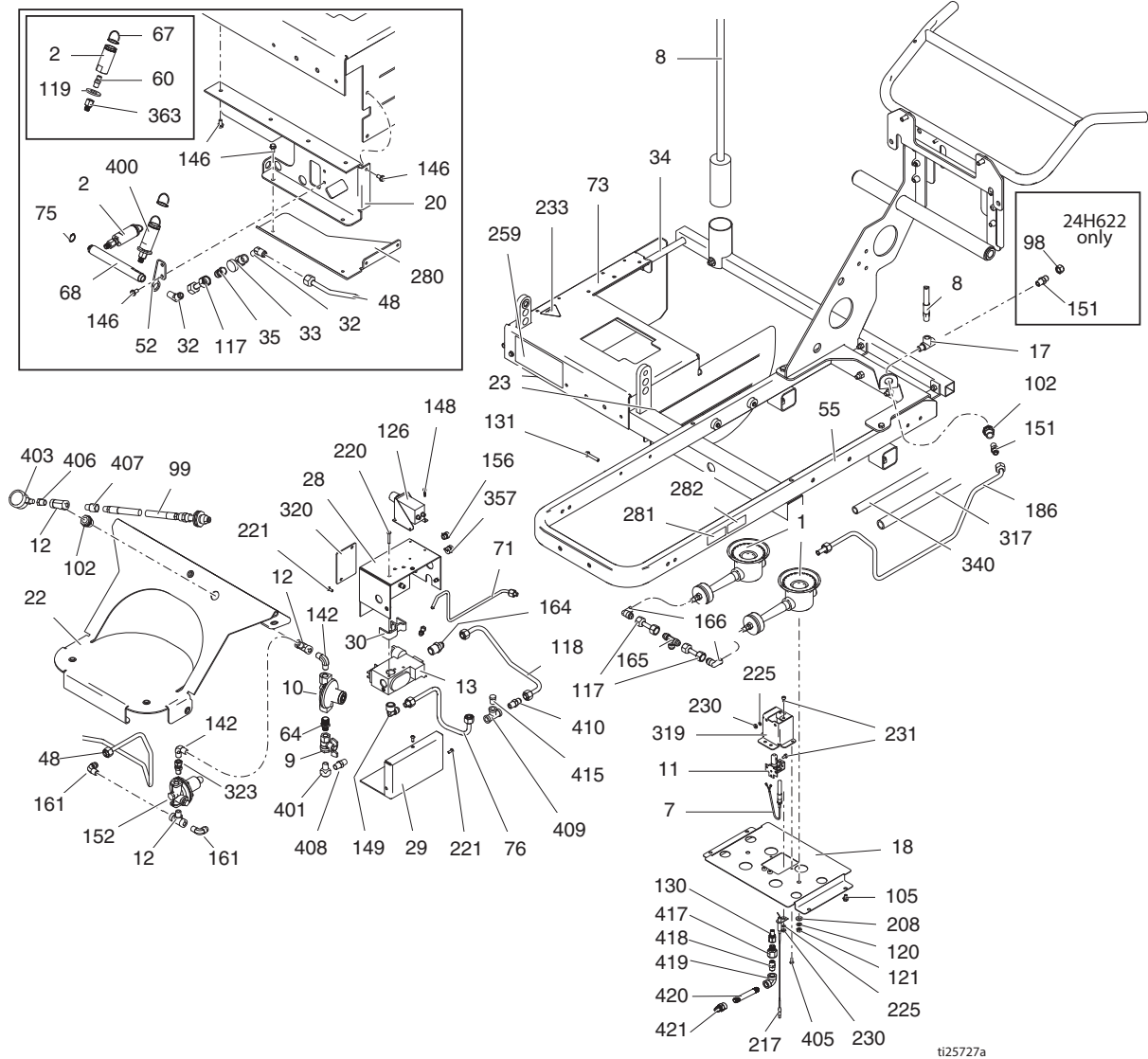

ti14228e

Parts List - ThermoLazer 300TC (Models 24H622, 24H625)

Ref.	Part	Description	Qty.	Ref.	Part	Description	Qty.
1	24C394	KIT, replacement, burner (Series A, B, and C Models)	2	148	122667	SCREW, drill, hex washer head	3
	16Y284*	RING, burner (Series D Models only)	2	149	118458	FITTING, elbow, male	1
2	24J570	KIT, repair, torch head, die (includes 67)	7	151	118484	FITTING, connector	2
		24H622	3	152**	24L884	KIT, REGULATOR, LP gas, 20 psi	1
		24H625	1	156	119545	BUSHING, strain, relief	2
7*	122944	FITTING, Thermopile	1	161	123155	FITTING, flared, 1/4 pipe, 90 elbow	3
8	125032	TOOL, torch	1	164	123157	FITTING, flared, 1/2 pipe, adapter	1
9	122946	VALVE, shut off	1	165*	123158	FITTING, flared, 3/8 tube, tee	1
10	24U191	KIT, repair, regulator	1	166*	125241	FITTING, flared, 1/8 npt x 90 elbow	2
11	24U190	KIT, repair, pilot, ThermoLazer (includes 130)	1	186	16F282	TUBE, formed, gas	1
12	108638	TEE, male	3	208*	110755	WASHER, plain	2
13	16F638	KIT, repair, valve, gas, ProMelt	1	217*	127255	ELECTRODE	1
17	106228	FITTING, tee, street	1	220	111235	SCREW, mach, pnh	3
1*8	16J484	PLATE, mount, burner	1	221	116610	SCREW, mach, phil, pan, #10	9
20	16H105	BRACKET, support, burner, front	1	225*	100020	WASHER, lock	3
22	16F641	BRACKET, support, tank, propane	1	230*	100179	NUT, hex mscr	2
23	15W735	ARM, chamber, die	1	231*	110637	SCREW, mach, panhead	5
28	24F695	ENCLOSURE, valve	1	233▲	16D646	LABEL, ISO, hot surface	5
29	16F642	COVER, enclosure, valve box	1	259	16J470	LABEL, front burner lighting instructions	1
30	16A708	BLOCK, spacer, gas valve	1	280	16J865	PLATE, skid, torch, protector	1
32	118482	FITTING, elbow, 45	2	282	24J404	LABEL, regulator	1
33	125064	VALVE, needle, gas, 1/4 npt	2	317	24J589	SLEEVE, high temp, 1/4, bulk	1
34	15Y339	ROD, support, die	1	319*	16W410	BRACKET	1
35	125063	FITTING, flared, 1/4 pipe, adapter	1	320	16C333	DOOR	1
48	16H128	TUBE, formed, gas	1	323	156823	FITTING, union, swivel	1
52	16H106	BRACKET, support, manifold, front	1	340	24J590	SLEEVE, high temp, 3/8, bulk	6
55	24J868	KIT, repair, frame, ThermoLazer (includes 281, 282)	1	357	120975	BUSHING, strain relief	1
64	157350	FITTING, nipple, pipe, hex	1	400	24T765	KIT, repair, torch up burner (includes 67)	1
67	16H104	INDICATOR, burner	7	401+	100840	FITTING, elbow, street	1
		24H622	3	403+	127257	GAUGE, 300 psi	1
		24H625	1	404	24T885	KIT, repair, gauges	1
68	24J577	KIT, repair, manifold, front	1	405*	114984	SCREW, tapping, phillips pan hd	1
71	24J572	TUBE, formed, gas	1	406+	100030	BUSHING	1
73	24J587	KIT, repair, shroud, die (includes 233, 259)	1	407+	16W635	FITTING, filter	1
75	113958	RING, retaining, external	3	408+	156971	FITTING, nipple, short	1
76	16J486	TUBE, formed, gas	1	409+	104984	FITTING, tee, pipe	1
98	100721	FITTING, cap	1	410+	118484	FITTING, connector	1
99	123086	HOSE, propane w/ polswivel adapter	1	415+		PLUG, 1/4 NPT Brass Hex Hd	1
102	104641	FITTING, bulkhead	2	416	24C113	KIT, repair, fitting, ferrule	1
105*	112798	SCREW, thread forming, hex HD	14	417*	555455	ADAPTER, 1/8 x 1/8 npt	1
117*	16A061	TUBE, formed, gas, ThermoLazer	3	418*	103656	NIPPLE, 1/8 x 1/8 npt, male	1
118	16W412	TUBE, formed, gas, ThermoLazer	1	419*	123725	ELBOW, 1/8 x 1/8 npt, female	1
120*	100016	WASHER, lock	2	420*	128444	NIPPLE, 2.5 in, 1/8 x 1/8 npt	1
121*	100015	NUT, hex mscr	4	421*	16Y514	ADAPTER, flared, 1/8 npt	1
126	123085	CONTROL, igniter, pulse	1				
130*	125323	FITTING, inlet, pilot	1				
131	114104	SCREW, mach, hex wash HD	10				
142	110249	ADAPTER, male elbow 90 degr	2				
146	107257	SCREW, thd forming	25				

▲ Replacement Danger and Warning labels, tags, and cards are available at no cost.

** Includes 323 Fitting, union swivel

+ Included in kit 24T885

* Included in kit 24U190

Parts - ThermoLazer 300TC (Models 24H622, 24H625)

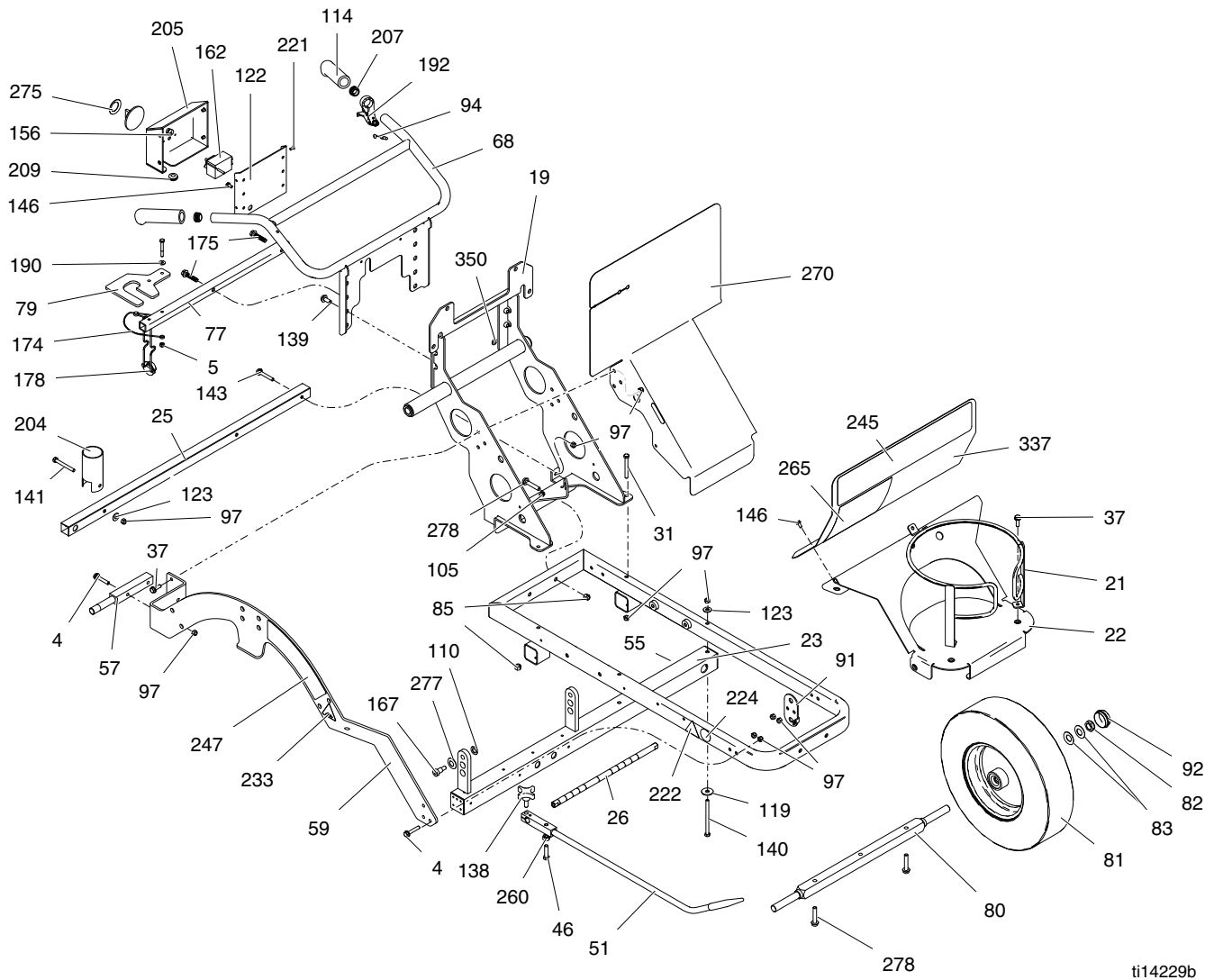

ti14229b

Parts List - ThermoLazer 300TC (Models 24H622, 24H625)

Ref.	Part	Description	Qty.	Ref.	Part	Description	Qty.
4	112960	SCREW, cap, flng HD	10	224▲	15Y963	LABEL ISO, read instructions	1
5	102040	NUT, lock, hex	2	233▲	16D646	LABEL, ISO, hot surfaces	5
19	24F693	BRACKET, handle, mount	1	247	16A317	LABEL, ThermoLazer, right	1
21	24F694	HOLDER, tank, propane	1	260	100131	NUT, full hex	3
22	16F641	BRACKET, support, tank, propane	1	270	16F660	SHIELD, heat, rear, ProMelt	1
23	15W735	ARM, chamber, die	1	275	16A873	LABEL, temperature control F & C	1
25	15X377	TUBE, support, beadbox	1	277	119563	WASHER, belleville	1
26	16A481	BAR, mount, indicator, line	1	278	114982	SCREW, cap, flng HD	11
31	110385	SCREW, cap, hex HD (5/16x3)	2	350	124655	GROMMET, high temp	1
37	112586	SCREW, cap, hex HD	13				
46	102637	SCREW, cap	3				
51	24C232	INDICATOR, line, ThermoLazer	1				
55	24J868	KIT, repair, frame, ThermoLazer (includes 222, 224)	1				
57	15W443	SHAFT, pivot, agitator	2				
59	24J584	KIT, repair, mount, ThermoLazer, right (includes 233, 247)	1				
68	15W992	BAR, handle	1				
77	15X286	TUBE, lock	1				
79	15X287	BRACKET, lock	1				
80	193405	AXLE	1				
81	111020	WHEEL, pneumatic	2				
82	112405	NUT, lock	6				
83	112825	SPRING, belleville	10				
85	101566	NUT, lock	12				
91	15F910	BRACKET, cable	1				
92	114648	CAP, dust	3				
94	241445	CABLE	1				
97	111040	NUT, lock, insert, nylock, 5/16	23				
105	112798	SCREW	14				
110	195134	SPACER, ball, guide	2				
114	114659	GRIP, handle	5				
119	108851	WASHER, plain	2				
122	15X995	COVER, control box	1				
123	100023	WASHER, flat	5				
138	111145	KNOB, pronged	1				
139	111192	SCREW, cap flang HD	26				
140	110384	SCREW, cap, hex HD	2				
141	113664	SCREW, cap, hex HD	1				
143	114653	SCREW, cap, flange head	2				
146	107257	SCREW, thd forming	22				
156	119545	BUSHING, strain, relief	2				
162	24C397	KIT, replacement, temperature control (includes 275)	1				
167	123199	SCREW, shoulder, socket head	3				
174	121458	TIE, lanyard	1				
175	117779	SCREW, hex head, flanged	6				
178	123186	TOOL, spark lighter	1				
190	170772	WASHER, plain	2				
192	194310	LEVER, actuator	1				
204	16H582	TUBE, torch holder	1				
205	15X993	BOX, control	1				
207	120151	RETAINER, caplug	3				
209	801012	GROMMET	1				
221	116610	SCREW, mach, phil, pan, #10	13				
222▲	16A274	LABEL, ISO, explosion	1				

▲ Replacement Danger and Warning labels, tags, and cards are available at no cost.

Parts - ThermoLazer 300TC (Models 24H622, 24H625)

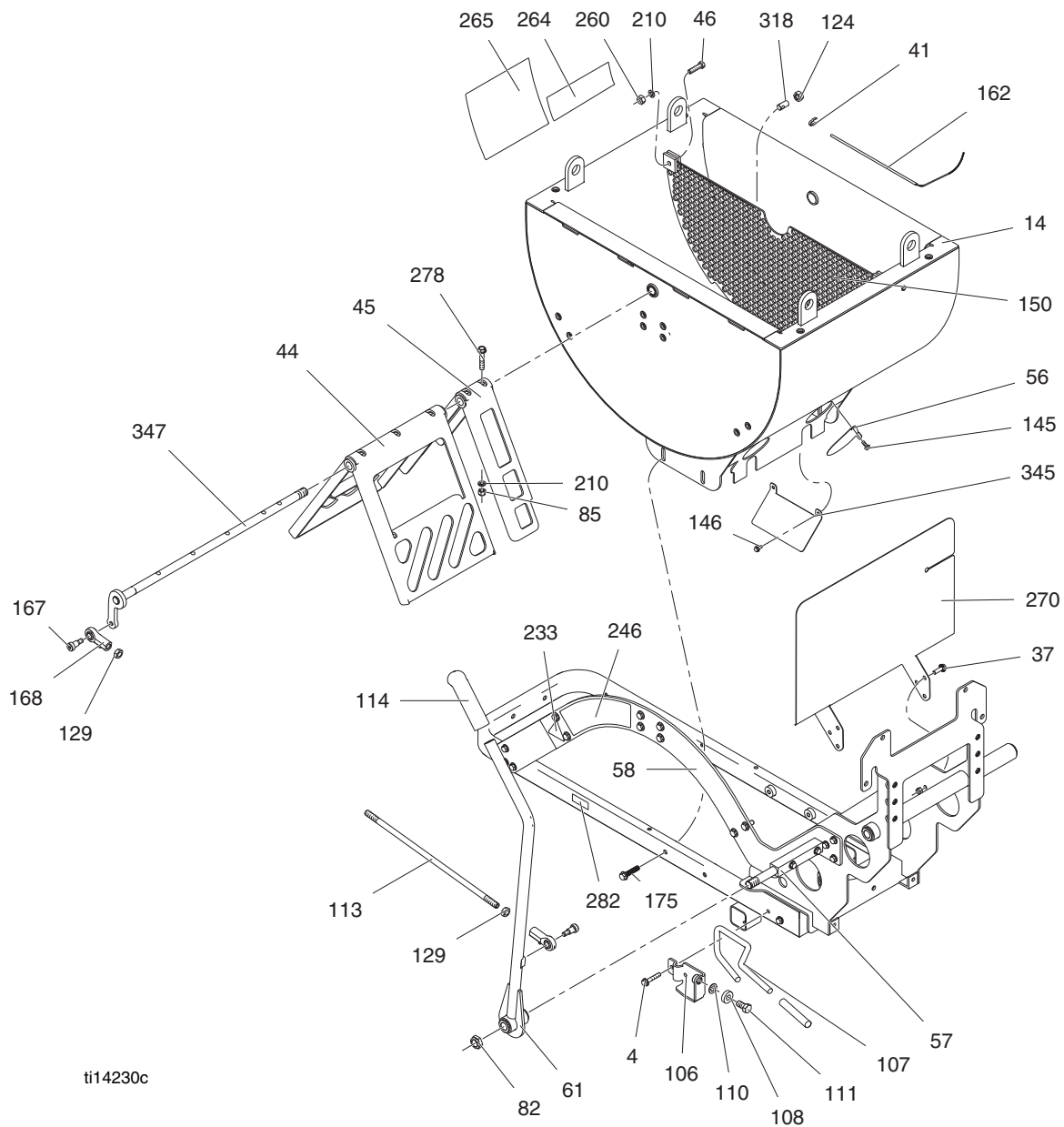

Parts List - ThermoLazer 300TC (Models 24H622, 24H625)

Ref.	Part	Description	Qty.
4	112960	SCREW, cap, flng HD	10
14	16A404	RESERVOIR, Thermolazer, painted	1
37	112586	SCREW, cap, hex HD	13
41	16C018	CLIP, holder, wire	3
44	24C633	AGITATOR, large	1
45	24C634	AGITATOR, small	1
46	102637	SCREW, cap	3
56	15W440	CHAMBER, heat, site door	2
57	15W443	SHAFT, pivot, agitator	2
58	24J585	KIT, repair, mount, left (includes 233, 246)	1
61	15W447	AGITATOR, arm	1
82	112405	NUT, lock	6
85	101566	NUT, lock	10
106	198891	BRACKET	1
107	198930	ROD, brake	1
108	198931	BEARING	1
110	195134	SPACER, ball, guide	2
111	113961	SCREW, cap, hex HD	1
113	15Y673	ROD, pivot, agitator	1
114	114659	GRIP, handle	5
124	100681	NUT, jam, hex	1
129	100111	NUT	2
145	112774	SCREW, mach, sltd hex wash HD	4
146	107257	SCREW, thd forming	22
150	15X215	SCREEN, kettle	1
162	24C397	KIT, replacement, temperature control (includes 41, 124, 318)	1
167	123199	SCREW, shoulder, socket head	4
168	123200	ROD, ball joint, end	2
175	117779	SCREW, hex head, flanged	6
210	100133	WASHER, lock, 3/8	9
233▲	16D646	LABEL, 2 in., ISO, hot surface	5
246	16A316	LABEL, brand, Thermolazer left	1
260	100131	NUT, full hex	3
265	15Y964	LABEL, footage counter	1
270	16F660	SHIELD, heat, rear, Promelt	1
278	114982	SCREW, cap, flng HD	11
282	24J404	LABEL, Promelt regulator label	1
318	15Y792	HOLDER, temp probe	1
345	15W733	DEFLECTOR, heat	2
347	258686	SHAFT, agitator	1

▲ Replacement Danger and Warning labels, tags, and cards are available at no cost.

Parts - ThermoLazer 300TC (Models 24H622, 24H625)

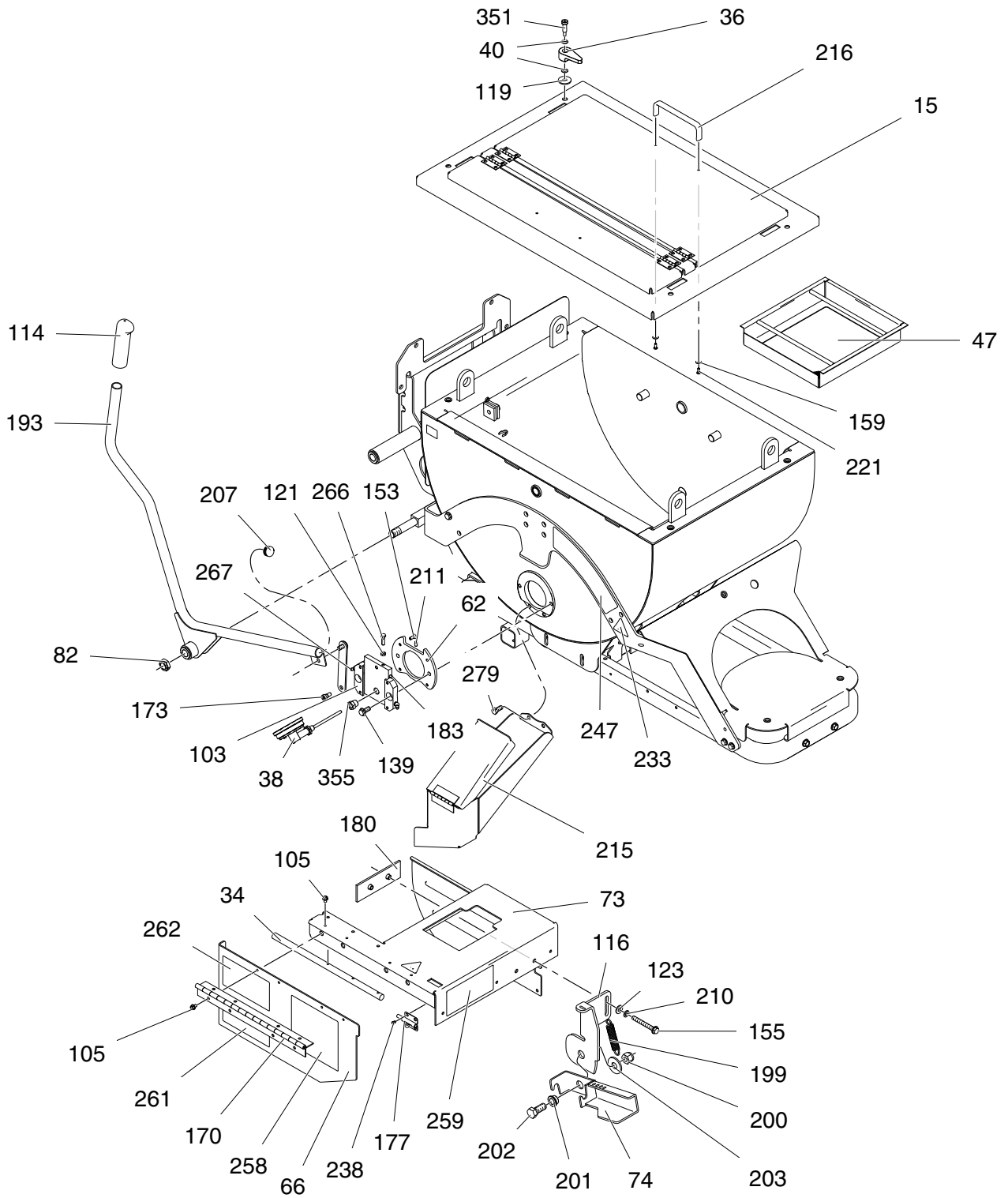

ti14231b

Parts List - ThermoLazer 300TC (Models 24H622, 24H625)

Ref.	Part	Description	Qty.
15	15W407	COVER, kettle	1
34	15Y339	ROD, support, die	1
36	15Y677	LATCH, cover	4
38	15Y679	THERMOMETER, temp gauge	1
40	113680	WASHER, wave	8
47	257368	SCREEN, inlet	1
62	16A065	FLANGE, mount, gate valve	1
66	24J588	KIT, shroud, die, door (includes 258, 261, 262)	1
73	24J587	KIT, shroud, die (includes 233, 259)	1
74	15W614	HANDLE, actuator	1
82	112405	NUT, lock	6
103	16A066	PLATE, guide, gate valve	2
105	112798	SCREW, thread forming, hex HD	12
114	114659	GRIP, handle	5
116	15W737	BRACKET, tension, die	1
119	108851	WASHER, plain	6
121	100015	NUT, hex mscr	4
123	100023	WASHER, flat	5
139	111192	SCREW, cap flang HD	26
153	123164	SCREW, sockethead, flat	4
155	116935	SCREW, cap, flnghd	2
159	112776	WASHER, plain (24H622 only)	4
170	123154	HINGE, access door	1
173	121256	SCREW, shoulder, skt HD	1
177	123099	LOCK, slide barrel	1
180	15Y949	PLATE, back support	1
183	24C105	GATE, valve, finished	1
193	24B811	HANDLE, gate valve	1
199	123206	SPRING, extension	1
200	101712	NUT, lock	1
201	123209	BEARING, flanged	1
202	123208	SCREW, cap, hex head	1
203	115028	WASHER, flat	1
207	120151	RETAINER, caplug	3
210	100133	WASHER, lock, 3/8	9
211	100664	SCREW, set, sch	1
215	24J084	FUNNEL, complete	1
216	15W412	HANDLE, cover	2
221	116610	SCREW, mach, phil, pan, #10	13
233▲	16D646	LABEL, 2 in., ISO, hot surface	5
238	123035	RIVET, blind	4
247	16A317	LABEL, brand, ThermoLazer right	1
258	16H841	LABEL, instruction, SmartDie II	1
259	16J470	LABEL, front burner lighting ins	1
261	16J468	LABEL, torch lighting instructio	1
262	16J469	LABEL, rear burner lighting inst	1
266	100021	SCREW, cap hex HD	1
267	100847	FITTING, lubrication	2
279	100680	SCREW, cap, hex HD	2
351	120476	BOLT, shoulder, 5/16	4
355	168160	BUSHING, pipe	1

▲ Replacement Danger and Warning labels, tags, and cards are available at no cost.

Parts - ProMelt (Model 24H624)

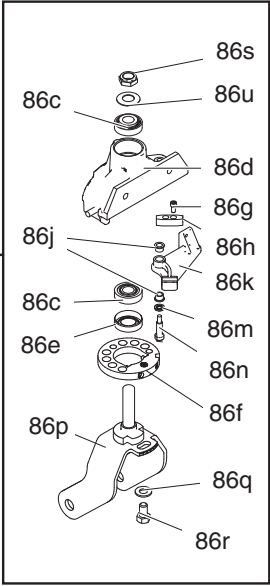
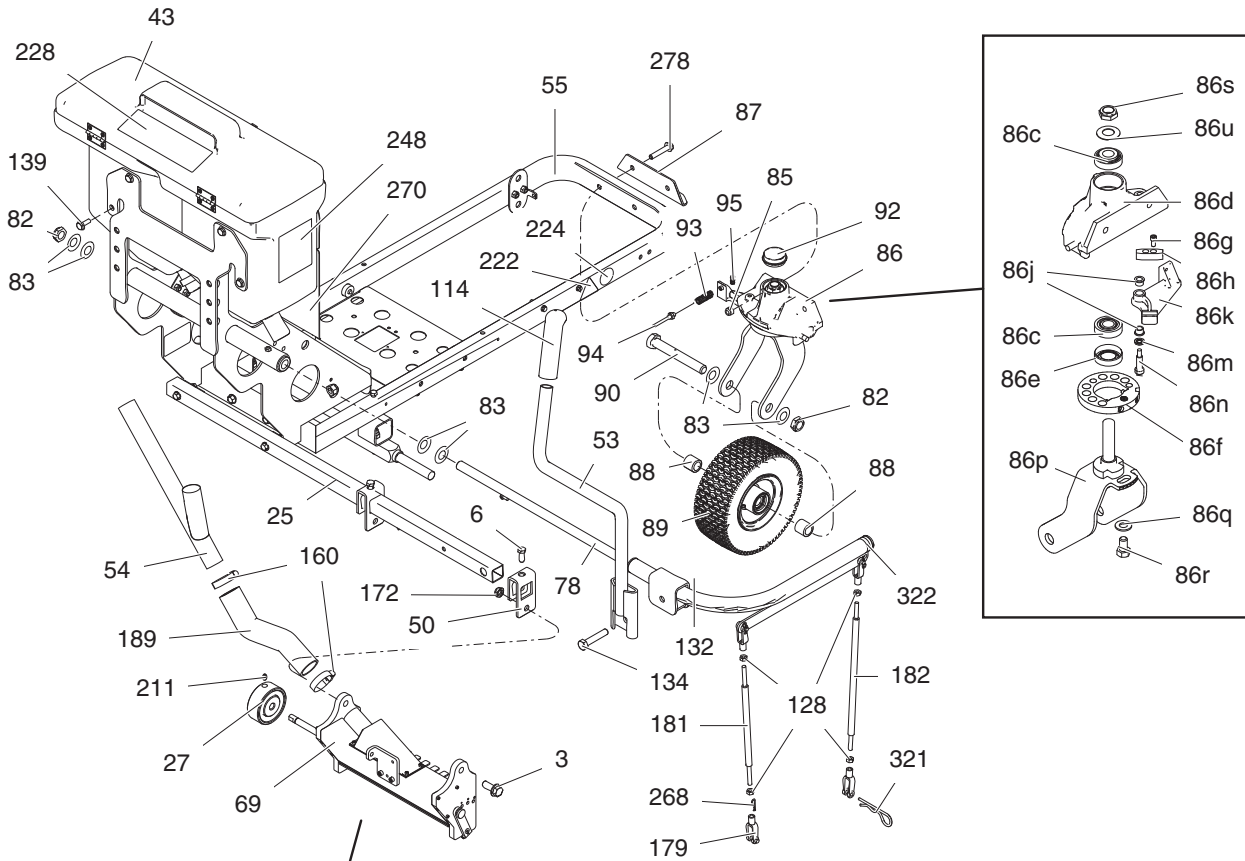

299 ti17085d

ti17085d

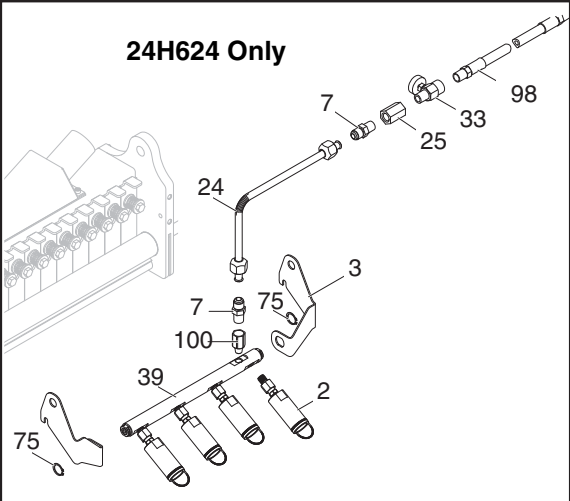
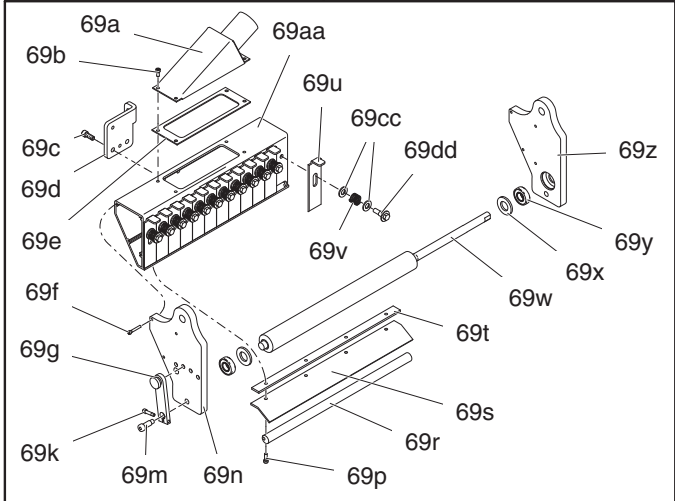

Parts List - ProMelt (Model 24H624)

Ref.	Part	Description	Qty.	Ref.	Part	Description	Qty.
2	24J570	KIT, repair, torch head, die	7	86p	17H485	SHAFT, fork	1
3	111195	SCREW, cap, flng HD	2	86q	113962	WASHER, hardened, SAE	1
6	100101	SCREW, cap, hex HD	2	86r	114681	SCREW, cap, hex HD	1
25	15X377	TUBE, support, beadbox	1	86s	112405	NUT, lock	1
27	15X765	WHEEL, drive, bead	1	86u	112825	SPRING, belleville	2
33	125064	VALVE, needle, gas, 1/4 npt	2	87	240991	BRACKET, caster, front	1
39	24J578	KIT, repair, manifold, rear	1	88	193658	NUT, seal	2
43	24J865	KIT, replacement, bead hopper (includes 228, 248, 264)	1	89	114549	WHEEL, pneumatic	1
50	257399	CLAMP, beadbox	2	90	113471	SCREW, cap, hex HD	1
53	257455	HANDLE, lift, die/bead dispenser	1	92	114648	CAP, dust	3
54	257617	CONNECTOR, bead box hose	1	93	114682	SPRING, compression	1
55	24J586	KIT, repair, frame, (includes 222, 224)	1	94	241445	KIT, cable	1
69	24R144	BOX,bead,12",with 1" gages	1	95	114802	STOP, wire	1
69a	257378	MANIFOLD, assembly	1	98	16Y249	HOSE, torch, rear	1
69b	112788	SCREW, cap, sockethead	4	100	159840	ADAPTER	1
69c	121112	SCREW, cap, sockethead	2	104	16H192	BRACKET, support, manifold, rear, left	1
69d	16U614	BRACKET, beadbox, linkage	1	109	16H107	BRACKET, support, manifold, rear, right	1
69e	16A243	GASKET, foam	1	114	114659	GRIP, handle	5
69f	110631	SCREW, sockethead	8	115	101550	SCREW, cap, sch	4
69g	24J866	HANDLE, adjuster, bead	1	128	100187	NUT	4
69k	295709	SCREW, cap, sockethead	1	132	801020	NUT, lock	1
69m	123481	SCREW, shoulder, screw, 1/4-20	2	134	114766	BOLT, cap hex head	1
69n	16H292	BRACKET, right, bead dispenser	1	139	111192	SCREW, cap flang HD	25
69p	112310	SCREW, cap, sch	4	151	118484	FITTING, connector	4
69r	15X281	ADJUSTER	1	160	116789	CLAMP, hose	6
69s	15X274	GATE, poly	1	172	119547	NUT, hex, lock, nylon, thin	2
69t	15X275	GATE, bar	1	179	15V415	CLEVIS	4
69u	16U612	PLATE, slide1"	12	181	16A041	SHAFT, threaded	1
69v	114708	SPRING, compression	12	182	16H291	SHAFT, threaded	1
69w	24C672	SHAFT, bead assembly kit	1	189	16A100	HOSE, bead	3
69x	114797	GASKET	2	211	100664	SCREW, set, sch	1
69y	123304	BEARING, double sealed	2	222▲	16A274	LABEL, ISO explosion	1
69z	16H293	BRACKET, left, bead dispenser	1	224	15Y963	LABEL, kettle burners lighting	1
69aa	16U613	HOUSING, dispenser 12",12 holes	1	228▲	16A276	LABEL, ISO symbols warn & instru	1
69cc	104034	WASHER, plain	24	248	16E335	LABEL, brand, Graco	2
69dd	119872	SCREW, shoulder	12	264▲	15Y966	LABEL, fire and explosion	1
75	113958	RING, retaining, external	3	268	120592	PIN, cotter, hairpin	3
78	15W873	ARM, die/bead dispenser	1	270	16F660	SHIELD, heat, rear, ProMelt	1
82	112405	NUT, lock	6	278	114982	SCREW, cap, flng HD	6
83	112825	SPRING, belleville	10	299	24H619	KIT, accessory, rear torch (includes 2, 98, 151, 33, 115, 104, 70, 60, 67, 109, 75, 39, 100, 112, 372, 373)	1
85	101566	NUT, lock	7				
86	24H246	CASTER, ProMelt, blue	1				
86c	113485	BEARING, cup/cone	2	321	123385	PIN, cotter, hairpin	2
86d	15G952	CASTER, machine	1	322	112853	PLUG, tubing	1
86e	113484	SEAL, grease	1	372	113093	CONNECTOR, pipe	1
86f	17H486	DISK, adjuster	1	373	16Y844	TUBE, formed, gas	1
86g	110754	SCREW, cap, sch	2	374	16Y885	KIT, rear die hose (includes 33, 98, 100, 151, 373)	1
86h	193662	STOP, wedge	1				
86j	114548	BEARING, bronze	2				
86k	193528	ARM, detent	1				
86m	15J603	SPACER, round, .625 in.	1				
86n	120476	BOLT, shoulder, 5/16	1				

▲ Replacement Danger and Warning labels, tags, and cards are available at no cost.

Parts List - ProMelt (Model 24H624)

Ref.	Part	Description	Qty.	Ref.	Part	Description	Qty.
1	24C394	KIT, replacement, burner (Series A, B and C Models)	2	149	118458	FITTING, elbow, male	1
	*16Y284	RING, burner (Series D Models only)	2	151	118484	FITTING, connector	4
2	24J570	KIT, repair, torch head, die (includes 67)	7	152**	24L884	KIT, REGULATOR, LP gas, 20 psi	1
7*‡	122944	FITTING, Thermopile	1	156	119545	BUSHING, strain, relief	2
8	125032	TOOL, torch	1	161	100840	FITTING, flared, 1/4 pipe, 90 elbow	2
9	122946	VALVE, shut off	1	164	123157	FITTING, flared, 1/2 pipe, adapter	1
10	**24L883	KIT, REGULATOR, LP gas, 5 psi (Series A, B and C Models only)	1	165*	123158	FITTING, flared, 3/8 tube, tee	1
	16Y705	KIT, regulator, LP gas, 3 psi (Series D Model)	1	166	125241	FITTING, flared, 1/8 npt x 90 elbow	2
11*	24T749	KIT, repair, pilot, (includes 130)	1	186	16F282	TUBE, formed, gas	1
12	108638	TEE, male	2	208*	110755	WASHER, plain	2
13	16F638	KIT, repair, valve, gas, (includes 71, 149, 164)	1	217*‡	127255	ELECTRODE	1
17	106228	FITTING, tee, street	1	220	111235	SCREW, mach, pnh	3
18*	16J484	PLATE, mount, burner	1	221	116610	SCREW, mach, phil, pan, #10	9
20	16H105	BRACKET, support, burner, front	1	225*‡	100020	WASHER, lock	3
22	16F641	BRACKET, support, tank, propane	1	230*‡	100179	NUT, hex mscr	3
23	15W735	ARM, chamber, die	1	231*‡	110637	SCREW, mach, panhead	6
28	24F695	ENCLOSURE, valve	1	233▲	16D646	LABEL, ISO, hot surfaces	5
29	16F642	COVER, enclosure, valve box	1	259	16J470	LABEL, front burner lighting	1
30	16A708	BLOCK, spacer, gas valve	1	280	16J865	PLATE, skid, torch, protector	1
32	118482	FITTING, elbow, 45	2	281	24J403	LABEL, regulator	1
33	125064	VALVE, needle, gas, 1/4 npt	2	282	24J404	LABEL, regulator	1
34	15Y339	ROD, support, die	1	317	24J589	KIT, repair, sleeve, heat, 1/4	1
35	125063	FITTING, flared, 1/4 pipe, adapter	1	319*‡	16W410	BRACKET	1
48	16H128	TUBE, formed, gas	1	320	16C333	DOOR	1
52	16H106	BRACKET, support, manifold, front	1	323	156823	FITTING, union swivel	1
55	24J586	KIT, repair, frame (includes 281, 282)	1	340	24J590	KIT, repair, sleeve, heat, 3/8	1
64	156971	FITTING, nipple, short	1	357	120975	BUSHING, strain relief	1
67	16H104	INDICATOR, burner	7	400	24T765	KIT, repair, torch up burner (includes 67)	1
68	24J577	KIT, repair, manifold, front	1	401+	100840	FITTING, elbow, street	1
71	24J572	KIT, repair, pilot, tube	1	402+	16Y229	GAUGE, 15 psi	1
73	24J587	KIT, repair, shroud, die (includes 233, 259)	1	403+	127257	GAUGE, 300 psi	1
75	113958	RING, retaining, external	3	404	24T750	KIT, repair, gauges	1
76	16J486	TUBE, formed, gas	1	405*‡	114984	SCREW, tapping, phillips pan hd	2
99	123086	HOSE, propane w/ polswivel adapter	1	406+	100030	BUSHING	1
102	104641	FITTING, bulkhead	2	407+	16W635	FITTING, filter	1
105*	112798	SCREW, thread forming, hex HD	14	408+	156971	FITTING, nipple, short	1
117*	16A061	TUBE, formed, gas	3	409+	104984	FITTING, tee, pipe	1
118	16W412	TUBE, formed, gas	1	410+	118484	FITTING, connector	1
120*	100016	WASHER, lock	2	411	24C113	KIT, repair, fitting, ferrule	1
121*	100015	NUT, hex mscr	4	412*	24S074	LABEL, 3 psi system	1
126	123085	CONTROL, igniter, pulse	1	417*‡	555455	ADAPTER, 1/8 x 1/8 npt	1
130*‡	125324	FITTING, inlet, pilot	1	418*‡	103656	NIPPLE, 1/8 x 1/8 npt, male	1
131	114104	SCREW, mach, hex wash HD	10	419*‡		ELBOW, 1/8 x 1/8 npt, female	1
142	110249	ADAPTER, male elbow 90 degr	2	420*‡	128444	NIPPLE, 2.5 in, 1/8 x 1/8 npt	1
146	107257	SCREW, thd forming	40	421*‡	16Y514	ADAPTER, flared, 1/8 npt	1
148	122667	SCREW, drill, hex washer head	3				

▲ Replacement Danger and Warning labels, tags, and cards are available at no cost.

** Includes 323 Fitting, union swivel

+ Included in kit 24T750

* Included in kit 24X017

‡ Included in Kit 24T749

Parts - ProMelt (Model 24H624)

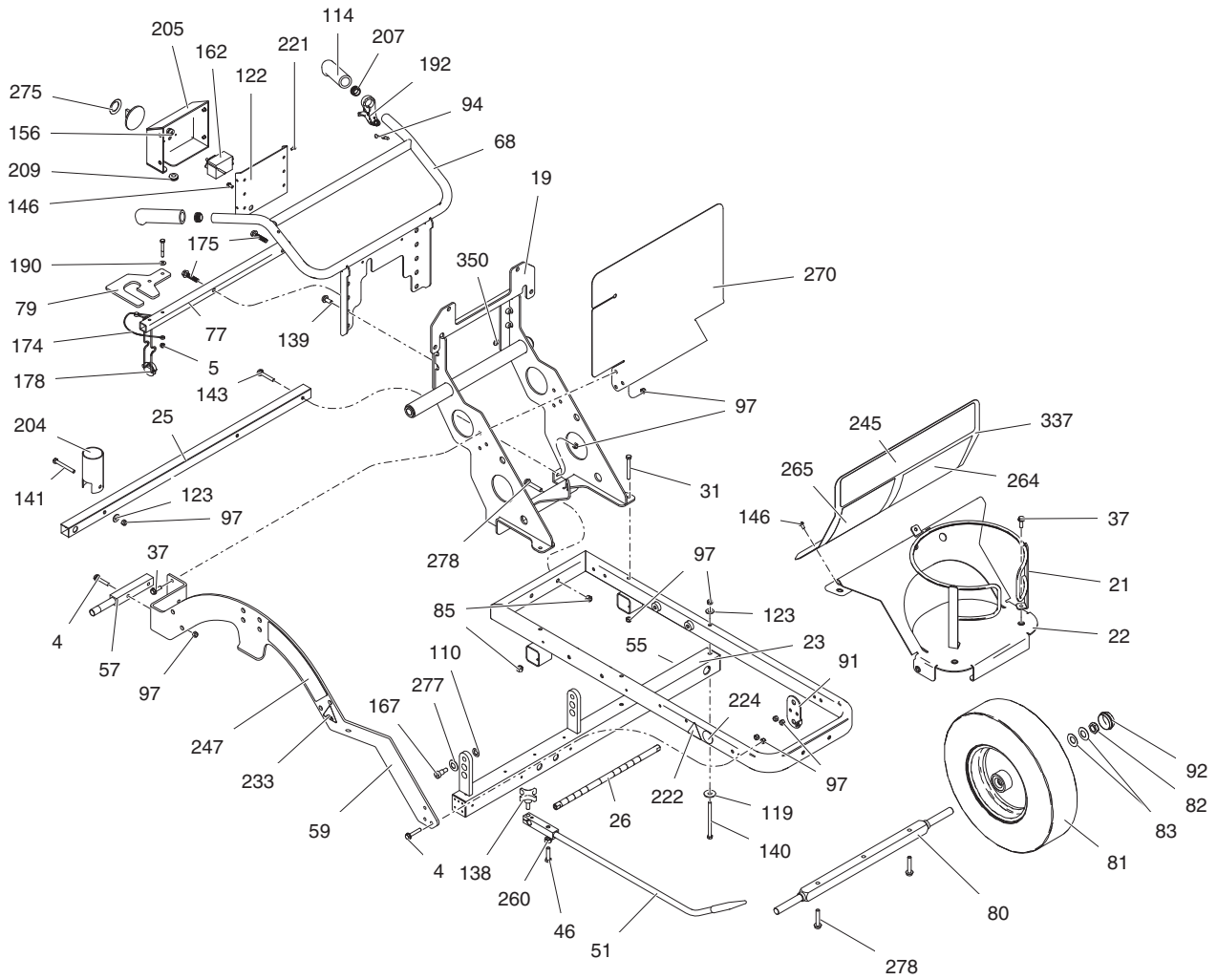

ti17087c

Parts List - ProMelt (Model 24H624)

Ref.	Part	Description	Qty.	Ref.	Part	Description	Qty.
4	112960	SCREW, cap, flng HD	10	224	15Y963	LABEL, kettle burners, lighting	1
5	102040	NUT, lock, hex	2	233▲	16D646	LABEL, ISO, hot surface	5
19	24F693	BRACKET, handle, mount	1	245	16H076	LABEL, brand, ThermoLazer Pro-Melt front	1
21	24F694	HOLDER, tank, propane	1	247	16H075	LABEL, brand, ThermoLazer Pro-Melt right	1
22	16F641	BRACKET, support, tank, propane	1	260	100131	NUT, full hex	1
23	15W735	ARM, chamber, die	1	265	15Y964	LABEL, kettle lighting instruction	1
25	15X377	TUBE, support, beadbox	1	270	16F660	SHIELD, heat, rear, Promelt	1
26	16A481	BAR, mount, indicator, line	1	275	16A873	LABEL, temperature control F & C	1
31	110385	SCREW, cap, hex HD (5/16x3)	2	277	119563	WASHER, belleville	1
37	112586	SCREW, cap, hex HD	14	278	114982	SCREW, cap, flng HD	6
46	102637	SCREW, cap	1	337	24J576	KIT, repair, heat shield, front (includes 245, 265)	1
51	24C232	INDICATOR, line, thermolazer	1	350	124655	GROMMET, high temp	1
55	24J586	KIT, repair, frame (includes 222, 224)	1				
57	15W443	SHAFT, pivot, agitator	2				
59	24J582	KIT, repair, mount, ProMelt, right (includes 233, 247)	1				
68	15W992	BAR, handle	1				
77	15X286	TUBE, lock	1				
79	15X287	BRACKET, lock	1				
80	193405	AXLE	1				
81	111020	WHEEL, pneumatic	2				
82	112405	NUT, lock	6				
83	112825	SPRING, belleville	10				
85	101566	NUT, lock	7				
91	15F910	BRACKET, cable	1				
92	114648	CAP, dust	3				
94	241445	KIT, repair, cable	1				
97	111040	NUT, lock, insert, nylock, 5/16	23				
105	112798	SCREW	14				
110	195134	SPACER, ball, guide	2				
114	114659	GRIP, handle	5				
119	108851	WASHER, plain	2				
122	15X995	COVER, control box	1				
123	100023	WASHER, flat	17				
138	111145	KNOB, pronged	1				
139	111192	SCREW, cap flang HD	25				
140	110384	SCREW, cap, hex HD	2				
141	113664	SCREW, cap, hex HD	1				
143	114653	SCREW, cap, flange head	2				
146	107257	SCREW, thd forming	37				
156	119545	BUSHING, strain, relief	2				
162	24J569	KIT, repair, temp, control ProMelt (includes 275)	1				
167	123199	SCREW, shoulder, socket head	3				
174	121458	TIE, lanyard	1				
175	117779	SCREW, hex head, flanged	6				
178	123186	TOOL, spark lighter	1				
190	170772	WASHER, plain	2				
192	194310	LEVER, actuator	1				
204	16H582	TUBE, torch holder	1				
205	15X993	BOX, control	1				
207	120151	RETAINER, caplug	3				
209	801012	GROMMET	1				
221	116610	SCREW, mach, phil, pan, #10	9				
222▲	16A274	LABEL, ISO, explosion	1				

▲ Replacement Danger and Warning labels, tags, and cards are available at no cost.

Parts - ProMelt (Model 24H624)

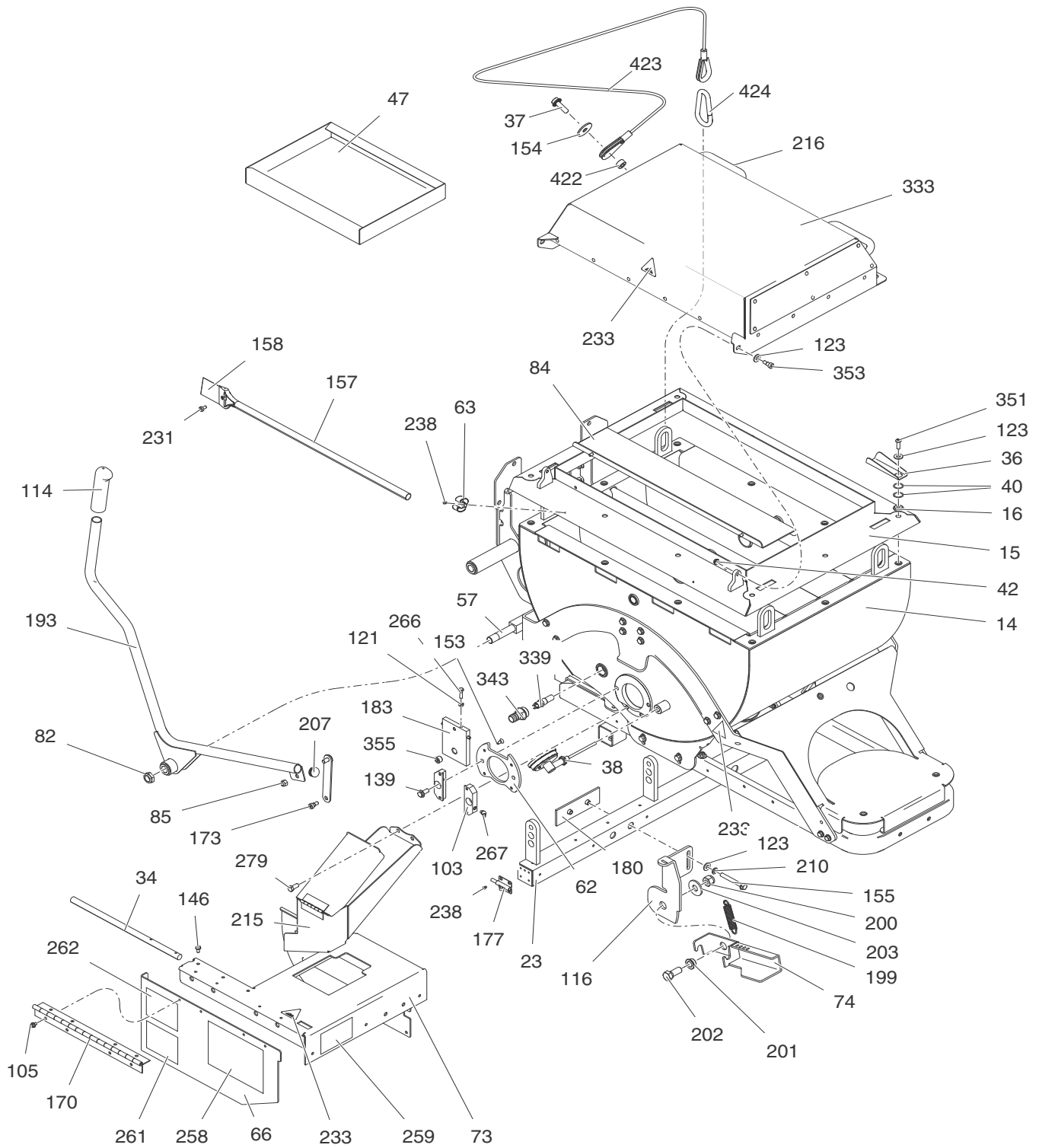

ti17088b

Parts List - ProMelt (Model 24H624)

Ref.	Part	Description	Qty.	Ref.	Part	Description	Qty.
14	24J579	KIT, repair, kettle, ProMelt	1	183	24C105	GATE, valve, finished	1
15	24F692	COVER, kettle, ProMelt	1	193	24B811	HANDLE, gate valve	1
16	16H285	SPACER, latch, ProMelt	2	199	123206	SPRING, extension	1
23	15W735	ARM, chamber, die	1	200	101712	NUT, lock	1
34	15Y339	ROD, support, die	1	201	123209	BEARING, flanged	1
36	16F643	LATCH, cover, Promelt	2	202	123208	SCREW, cap, hex head	1
37	112586	SCREW, cap, hex hd	1	203	115028	WASHER, flat	1
38	15Y679	THERMOMETER, temp gauge	1	207	120151	RETAINER, caplug	3
40	116038	WASHER, wave spring	4	210	100133	WASHER, lock, 3/8	2
42	115942	NUT, hex, flange head	2	215	24J084	FUNNEL, complete	1
47	16F697	SCREEN, inlet, ProMelt	1	216	16F727	HANDLE, cover	2
57	15W443	SHAFT, pivot, agitator	2	231	110637	SCREW, machine, panhead	6
62	16A065	FLANGE, mount, gate valve	1	233▲	16D646	LABEL, ISO, hot surface	5
63	125270	RETAINER, clip	2	238	123035	RIVET, blind	6
66	24J588	KIT, shroud, door, die (includes 258, 261, 262)	1	258	16H841	LABEL, SmartDie II, instructions	1
73	24J587	KIT, shroud, die (includes 233, 259)	1	259	16J470	LABEL, front burner lighting instructions	1
74	15W614	HANDLE, actuator	1	261	16J468	LABEL, torch lighting instructions	1
82	112405	NUT, lock	5	262	16J469	LABEL, rear screed burner	1
84	16H286	PLATE, filler, kettle	1	266	100021	SCREW, cap hex HD	1
85	101566	NUT, lock	7	267	100847	FITTING, lubrication	2
103	16A066	PLATE, guide, gate valve	2	279	100680	SCREW, cap, hex HD	2
105	112798	SCREW, thread forming, hex HD	12	333	24J867	KIT, repair, lid (includes 216, 233, 354)	1
114	114659	GRIP, handle	5	339	124610	SENSOR, high temp, control	1
116	15W737	BRACKET, tension, die	1	343	16F655	PLUG, thermowell, ProMelt	1
121	100015	NUT, hex mscr	4	351	125112	SCREW, cap, btn HD, 5/16 X 1	10
123	100023	WASHER, flat	17	353	108859	SCREW, shoulder, sch (24H624 only)	2
139	111192	SCREW, cap flang HD	25	355	101754	PLUG, pipe	1
146	107257	SCREW, thd forming	37	365	24J573	KIT, repair, lid, Promelt (includes 63, 238, 84, 42, 15, 16, 40, 36, 123, 351, 333, 353, 123, 146)	1
153	123164	SCREW, sockethead, flat	4	422	17S349	SPACER, cover	1
154	120659	WASHER, flat	1	423	17S350	CABLE, lanyard	1
155	116935	SCREW, cap, flnghd	2	424	17S351	ADAPTER, carabiner	1
157	24J179	KIT, accessory, scraper, long (includes 158, 231)	1				
158	24J356	BLADE, scraper (5 pk)	1				
170	123154	HINGE, access door	1				
173	121256	SCREW, shoulder, skt HD	1				
177	123099	LOCK, slide barrel	1				
180	15Y949	PLATE, back support	1				

▲ Replacement Danger and Warning labels, tags, and cards are available at no cost.

Parts - ProMelt (Model 24H624)

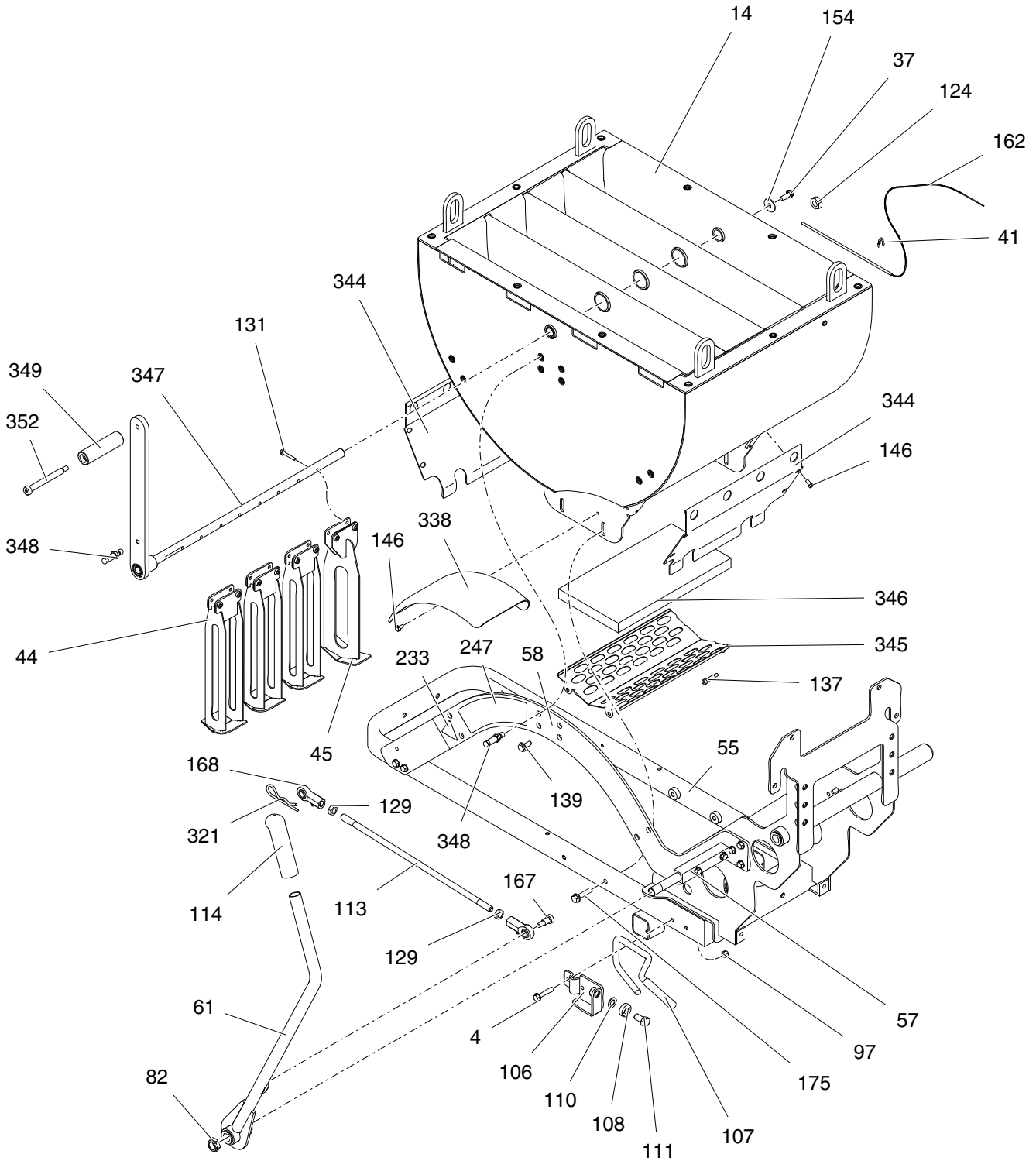

ti17089b

Parts List - ProMelt (Model 24H624)

Ref.	Part	Description	Qty.
4	112960	SCREW, cap, flng HD	10
14	24J579	KIT, repair, kettle, ProMelt (includes 344, 56, 345, 346, 145, 146, 137)	1
37	112586	SCREW, cap, hex HD	14
41	16C018	CLIP, holder, wire	1
44	24F696	AGITATOR, ProMelt, wide	3
45	24F697	AGITATOR, ProMelt, narrow	1
55	24J586	KIT, repair, frame	1
57	15W443	SHAFT, pivot, agitator	2
58	24J583'	KIT, repair, mount, ProMelt, left (includes 233, 247)	1
61	15W447	AGITATOR, arm	1
82	112405	NUT, lock	5
97	111040	NUT, lock, insert, nylock, 5/16	23
106	198891	BRACKET	1
107	198930	ROD, brake	1
108	198931	BEARING	1
110	195134	SPACER, ball, guide	2
111	113961	SCREW, cap, hex HD	1
113	16F729	ROD, threaded, ProMelt	1
114	114659	GRIP, handle	5
124	100681	NUT, jam, hex	1
129	100111	NUT	2
131	114104	SCREW, mach, hex wash HD	10
137	111045	SCREW, shoulder	4
139	111192	SCREW, cap flang HD	25
146	107257	SCREW, thd forming	37
154	120659	WASHER, falt	1
162	24J569	KIT, repair, temperature control, ProMelt (includes 41, 124)	1
167	123199	SCREW, shoulder, socket head	3
168	123200	ROD, ball joint, end	2
175	117779	SCREW, hex head, flanged	6
233▲	16D646	LABEL, ISO, hot surface	5
247	16H074	LABEL, ThermoLazer ProMelt	1
321	123385	PIN, cotter, hairpin	2
338	16H584	FENDER, ProMelt	2
344	16F656	SHIELD, kettle, bottom, ProMelt	2
345	24J571	KIT, repair, baffle, kettle (includes 346, 137)	1
346	16F658	BAFFLE, heat, insulated, ProMelt	1
347	24F699	SHAFT, agitator, ProMelt	1
348	16F728	FITTING, arm mount agitator	2
349	16F645	HANDLE, agitator, ProMelt	1
352	124628	SCREW, shoulder, sch	1

▲ Replacement Danger and Warning labels, tags, and cards are available at no cost.

Parts - SmartDie II Box

17A173	2 in. (5 cm)
24H431	3 in. (8 cm)
24H426	4 in. (10 cm)
17J250	4.75 in. (12 cm)
24H432	5 in. (13 cm)
24H427	6 in. (15 cm)
24H433	7 in. (18 cm)
24H428	8 in. (20 cm)
24H434	9 in. (22.5 cm)
24H429	10 in. (25 cm)
24H430	12 in. (30 cm)
17A174	16 in. (40 cm)

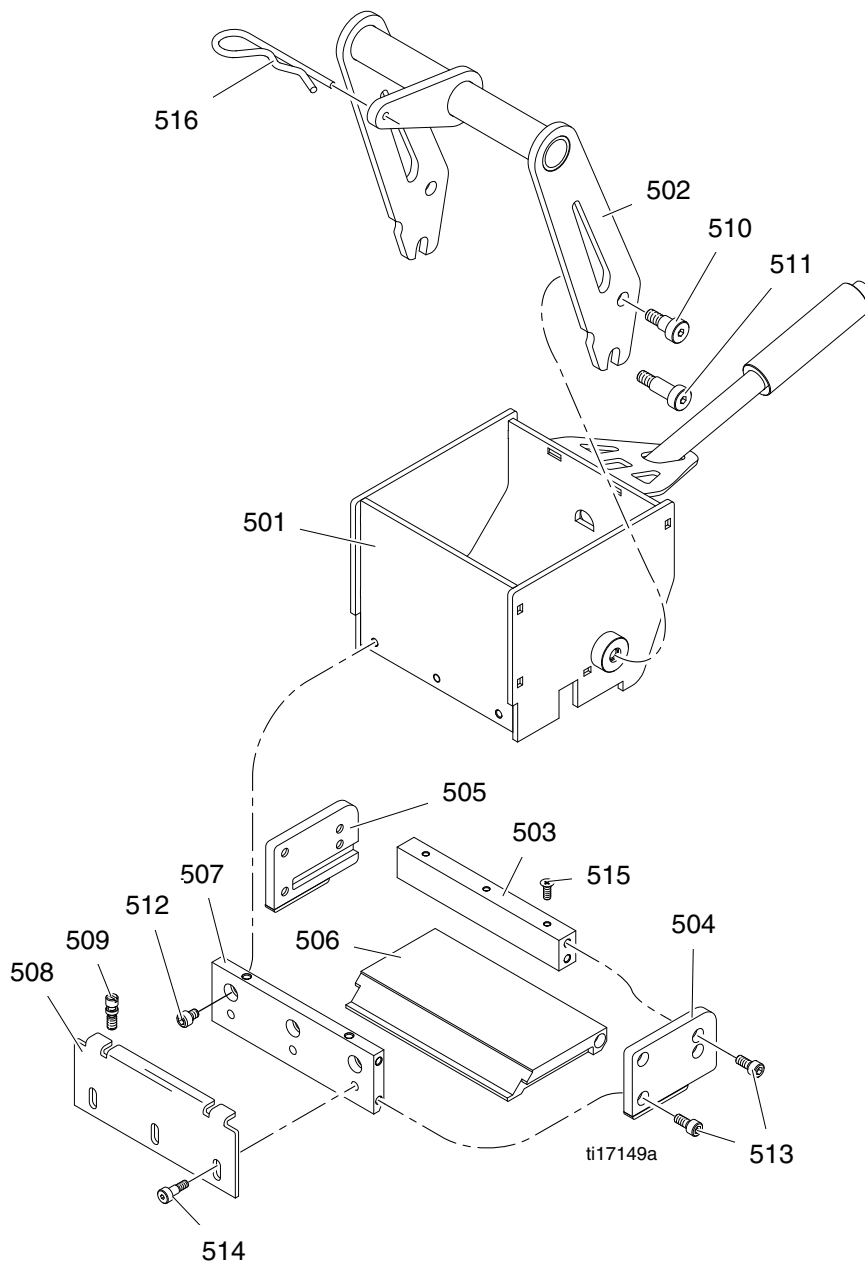

Parts List - SmartDie II Box

Ref.	Part	Description	Qty.	Ref.	Part	Description	Qty.
501	24H565	BOX, die, weldment (17A173)	1		16H022	BAR, shear (24H434)	1
	24H562	BOX, die, weldment (24H431)	1		16H017	BAR, shear (24H429)	1
	24H563	BOX, die, weldment (24H426)	1		16H018	BAR, shear(24H430)	1
	17J251	BOX, die, weldment (17J250)	1		17A185	BAR, shear (17A174)	1
	24H564	BOX, die, weldment (24H432)	1	507	16H025	BAR, shear, stop (17A173)	1
	24H565	BOX, die, weldment (24H427)	1		16H029	BAR, shear, stop (24H431)	1
	24H566	BOX, die, weldment (24H433)	1		16H024	BAR, shear, stop (24H426)	1
	24H567	BOX, die, weldment (24H428)	1		17J263	BAR, shear, stop (17J250)	1
	24H568	BOX, die, weldment (24H434)	1		16H030	BAR, shear, stop (24H432)	1
	24H569	BOX, die, weldment (24H429)	1		16H025	BAR, shear, stop (24H427)	1
	24H570	BOX, die, weldment (24H430)	1		16H031	BAR, shear, stop (24H433)	1
	17A176	BOX, die, weldment(17A174)	1		16H026	BAR, shear, stop (24H428)	1
502	24H574	YOKE, weldment (17A173)	1		16H032	BAR, shear, stop (24H434)	1
	24H571	YOKE, weldment (24H431)	1		16H027	BAR, shear, stop (24H429)	1
	24H572	YOKE, weldment (24H426)	1		16H028	BAR, shear, stop (24H430)	1
	17J256	YOKE, weldment (17J250)	1		17A187	BAR, shear, stop (17A184)	1
	24H573	YOKE, weldment (24H432)	1	508	17A188	PLATE, screed, adjustable (17A173)	1
	24H574	YOKE, weldment (24H427)	1		16H033	PLATE, screed, adjustable (24H431)	1
	24H575	YOKE, weldment (24H433)	1		16H034	PLATE, screed, adjustable (24H426)	1
	24H576	YOKE, weldment (24H428)	1		17J264	PLATE, screed, adjustable (17J250)	1
	24H577	YOKE, weldment (24H434)	1		16H035	PLATE, screed, adjustable (24H432)	1
	24H578	YOKE, weldment (24H429)	1		16H036	PLATE, screed, adjustable (24H427)	1
	24H579	YOKE, weldment (24H430)	1		16H037	PLATE, screed, adjustable (24H433)	1
	17A179	YOKE, weldment (17A174)	1		16H038	PLATE, screed, adjustable (24H428)	1
503	16G996	BAR, support (17A173)	1		16H039	PLATE, screed, adjustable (24H434)	1
	16H001	BAR, support (24H431)	1		16H040	PLATE, screed, adjustable (24H429)	1
	16G995	BAR, support (24H426)	1		16H041	PLATE, screed, adjustable (24H430)	1
	17J260	BAR, support (17J250)	1		17A189	PLATE, screed, adjustable (17A184)	1
	16H006	BAR, support (24H432)	1	509	16H044	SCREW, adjustment, screed	2
	16G996	BAR, support (24H427)	1	510	125028	SCREW, shoulder, socket head M8	2
	16H007	BAR, support (24H433)	1	511	125027	SCREW, shoulder, socket head M8	2
	16G997	BAR, support (24H428)	1	512	110501	SCREW, cap sch, M6 x 8	7
	16H008	BAR, support (24H434)	1			(24H431,24H426, 24H432, 24H427,	
	16G998	BAR, support (24H429)	1			24H433 ,24H428, 24H434, 24H429,	
	16G999	BAR, support (24H430)	1			24H430)	
	17A183	BAR, support (17A174)	1	513	121518	SCREW, cap, shc	8
504	24H581	PLATE, die runner, right	1	514	125029	SCREW, shoulder, socket head M5	5
505	24H580	PLATE, die runner, left	1			(24H431,24H426, 24H432, 24H427,	
506	17A184	BAR, shear (17A173)	1			24H433 ,24H428, 24H434, 24H429,	
	16H019	BAR, shear (24H431)	1			24H430))	
	16H014	BAR, shear (24H426)	1	515	123340	SCREW, mach, flat head, undercut	6
	17J262	BAR, shear (17J250)	1			(24H431,24H426, 24H432, 24H427,	
	16H020	BAR, shear (24H432)	1			24H433 ,24H428, 24H434, 24H429,	
	16H015	BAR, shear (24H427)	1			24H430))	
	16H021	BAR, shear (24H433)	1	516	123385	PIN	1
	16H016	BAR, shear (24H428)	1				

Parts - Double Line Die Box

24H435	4-3-4 in. (10-8-10 cm)
24H436	4-4-4 in. (10-10-10 cm)
24H437	3-3-3 in. (8-8-8 cm)
24J785	4-6-4 in. (10-15-10 cm)
17R378	5-5-5 in. (13-13-13 cm)

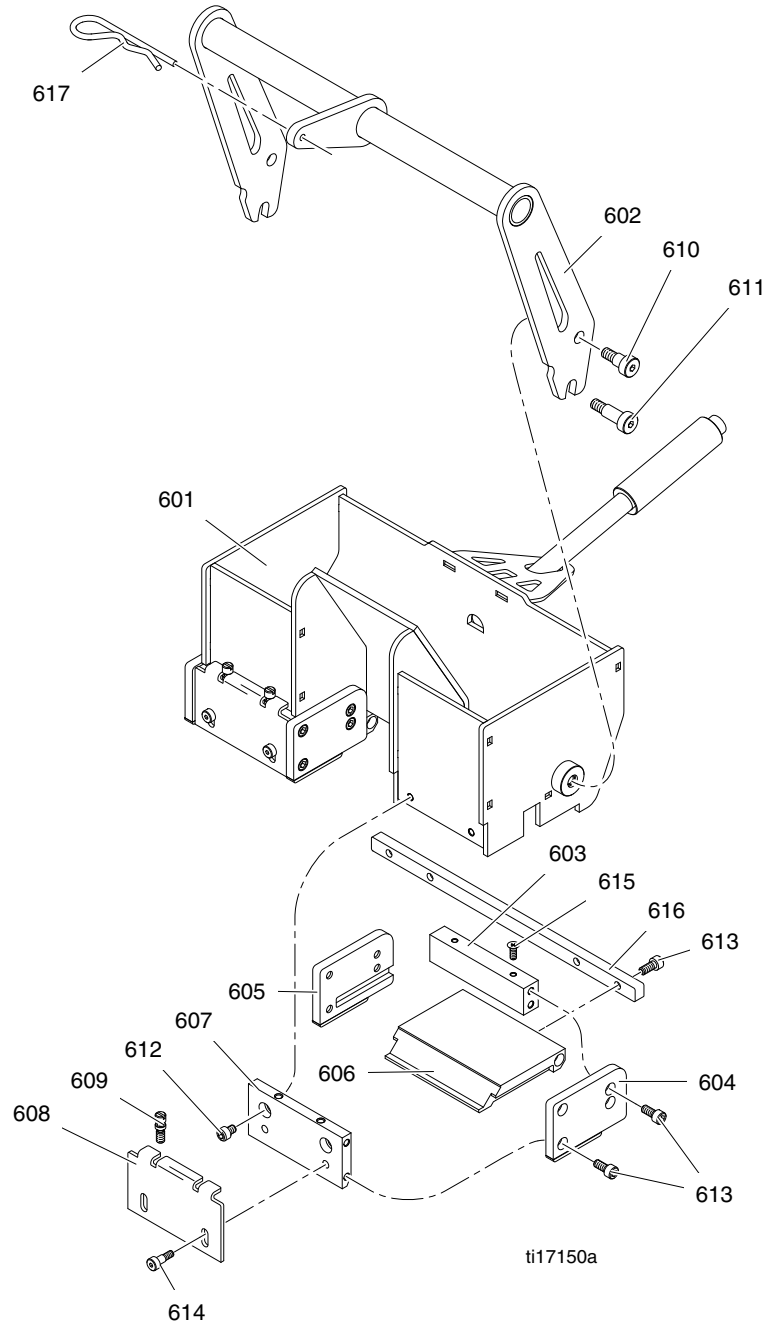

Parts List - Double Line Die Box

Ref. Part	Description	Qty.
601 24H647	BOX, die, weldment (24H435)	1
24H648	BOX, die, weldment (24H436)	1
24H649	BOX, die, weldment (24H437)	1
24J784	BOX, die, weldment (24J785)	1
17R379	BOX, die, weldment (17R378)	1
602 24H652	YOKE, weldment (24H435)	1
24H579	YOKE, weldment (24H436)	1
24H577	YOKE, weldment (24H437)	1
24J783	YOKE, weldment (24J785)	1
17R382	YOKE, weldment (17R378)	1
603 16G995	BAR, support (24H435)	1
16G995	BAR, support (24H436)	1
16H001	BAR, support (24H437)	1
16G995	BAR, support (24J785)	1
16H006	BAR, support (17R378)	1
604 24H581	PLATE, die runner, right	2
605 24H580	PLATE, die runner, left	2
606 16H159	BAR, shear, die, double (24H435)	1
16H159	BAR, shear, die, double (24H436)	1
16H160	BAR, shear, die, double (24H437)	1
16H159	BAR, shear, die, double (24J785)	1
17R384	BAR, shear, die, double (17R378)	1
607 16H024	BAR, shear, stop (24H435)	2
16H024	BAR, shear, stop (24H436)	2
16H029	BAR, shear, stop (24H437)	1
16H024	BAR, shear, stop (24J785)	2
16H030	BAR, shear, stop (17R378)	2
608 16H034	PLATE, screed, adjustable (24H435)	2
16H034	PLATE, screed, adjustable (24H436)	2
16H041	PLATE, screed, adjustable (24H437)	1
16H034	PLATE, screed, adjustable (24J785)	2
16H035	PLATE, screed, adjustable (17R378)	2
609 16H044	SCREW, adjustment, screed	4
610 125028	SCREW, shoulder, socket head M8	4
611 125027	SCREW, shoulder, socket head M8	4
612 110501	SCREW, cap, sch M6 x 8	4
	SCREW, cap, sch M6 X 8 (17R378)	6
613 121518	SCREW, cap, shc	20
614 125029	SCREW, shoulder, socket head M5	4
	SCREW, shoulder, socket head M5 (17R378)	6
615 123340	SCREW, mach, flat head, undercut	4
	SCREW, mach, flat head, undercut (17R378)	6
616 16H189	GUIDE, bar, shear, double (24H435)	1
16H161	GUIDE, bar, shear, double (24H436)	1
16H162	GUIDE, bar, shear, double (24H437)	1
16J802	GUIDE, bar, shear, double (24J785)	1
17R385	GUIDE, bar, shear, double (17R378)	1
617 123385	PIN	1

Graco Standard Warranty

Graco warrants all equipment referenced in this document which is manufactured by Graco and bearing its name to be free from defects in material and workmanship on the date of sale to the original purchaser for use. With the exception of any special, extended, or limited warranty published by Graco, Graco will, for a period of twelve months from the date of sale, repair or replace any part of the equipment determined by Graco to be defective. This warranty applies only when the equipment is installed, operated and maintained in accordance with Graco's written recommendations.

This warranty does not cover, and Graco shall not be liable for general wear and tear, or any malfunction, damage or wear caused by faulty installation, misapplication, abrasion, corrosion, inadequate or improper maintenance, negligence, accident, tampering, or substitution of non-Graco component parts. Nor shall Graco be liable for malfunction, damage or wear caused by the incompatibility of Graco equipment with structures, accessories, equipment or materials not supplied by Graco, or the improper design, manufacture, installation, operation or maintenance of structures, accessories, equipment or materials not supplied by Graco.

This warranty is conditioned upon the prepaid return of the equipment claimed to be defective to an authorized Graco distributor for verification of the claimed defect. If the claimed defect is verified, Graco will repair or replace free of charge any defective parts. The equipment will be returned to the original purchaser transportation prepaid. If inspection of the equipment does not disclose any defect in material or workmanship, repairs will be made at a reasonable charge, which charges may include the costs of parts, labor, and transportation.

THIS WARRANTY IS EXCLUSIVE, AND IS IN LIEU OF ANY OTHER WARRANTIES, EXPRESS OR IMPLIED, INCLUDING BUT NOT LIMITED TO WARRANTY OF MERCHANTABILITY OR WARRANTY OF FITNESS FOR A PARTICULAR PURPOSE.

Graco's sole obligation and buyer's sole remedy for any breach of warranty shall be as set forth above. The buyer agrees that no other remedy (including, but not limited to, incidental or consequential damages for lost profits, lost sales, injury to person or property, or any other incidental or consequential loss) shall be available. Any action for breach of warranty must be brought within two (2) years of the date of sale.

GRACO MAKES NO WARRANTY, AND DISCLAIMS ALL IMPLIED WARRANTIES OF MERCHANTABILITY AND FITNESS FOR A PARTICULAR PURPOSE, IN CONNECTION WITH ACCESSORIES, EQUIPMENT, MATERIALS OR COMPONENTS SOLD BUT NOT MANUFACTURED BY GRACO. These items sold, but not manufactured by Graco (such as electric motors, switches, hose, etc.), are subject to the warranty, if any, of their manufacturer. Graco will provide purchaser with reasonable assistance in making any claim for breach of these warranties.

In no event will Graco be liable for indirect, incidental, special or consequential damages resulting from Graco supplying equipment hereunder, or the furnishing, performance, or use of any products or other goods sold hereto, whether due to a breach of contract, breach of warranty, the negligence of Graco, or otherwise.

Graco Information

For the latest information about Graco products, visit www.graco.com.

For patent information, see www.graco.com/patents.

TO PLACE AN ORDER, contact your Graco distributor or call 1-800-690-2894 to identify the nearest distributor.

All written and visual data contained in this document reflects the latest product information available at the time of publication. Graco reserves the right to make changes at any time without notice.

For patent information, see www.graco.com/patents.

Original instructions. This manual contains English. MM 3A1321

Graco Headquarters: Minneapolis

International Offices: Belgium, China, Japan, Korea

GRACO INC. AND SUBSIDIARIES • P.O. BOX 1441 • MINNEAPOLIS MN 55440-1441 • USA

Copyright 2011, Graco Inc. All Graco manufacturing locations are registered to ISO 9001.

www.graco.com

Revision N, August 2017