

Pump Expansion Kits

332456C

EN

To add a third or fourth pump to a ProMix® PD2K, or to add pumps to a PD1K Proportioner. Each kit includes one pump and associated parts. PD2K is shown with two kits added. For professional use only.



Important Safety Instructions

Read all warnings and instructions in this manual and in your PD2K manual. Save these instructions.

See page 3 for model part numbers and approvals information.

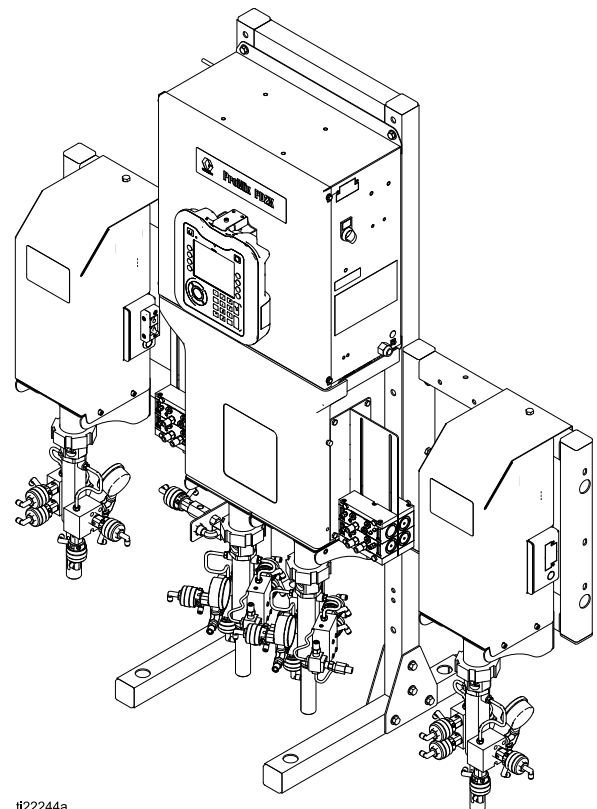

i22244a

Contents

Related Manuals	2	TSL Cup Kit	12
Models	3	Fluid Connections	15
Warnings	4	Electrical Connections	16
Important Isocyanate (ISO) Information	6	Grounding	18
Isocyanate Conditions	6	Complete the Installation	19
Material Self-ignition	6	Repair	21
Keep Components A and B Separate	6	Dose Valve Tubing Connections	21
Moisture Sensitivity of Isocyanates	6	Replace Pump Control Module	23
Changing Materials	7	Electrical Schematics	24
Important Acid Catalyst Information	8	Standard Models (MC1000, MC2000, MC3000, MC4000)	24
Acid Catalyst Conditions	8	Dual Panel Models (MC1002, MC2002, MC4002)	30
Moisture Sensitivity of Acid Catalysts	8	Pump Expansion Kit Parts	36
Installation	9	Technical Data	39
Before Installing the Kit	9		
Install the Frame	10		
Install the Wall Bracket	11		

Related Manuals

Manual No.	Description
3A2800	PD2K Proportioner Repair-Parts Manual, Manual Systems
332457	PD2K Proportioner Installation Manual, Manual Systems
332562	PD2K Proportioner Operation Manual, Manual Systems
3A2801	Mix Manifold Instructions-Parts Manual
332709	PD2K Proportioner Repair-Parts Manual, Automatic Systems
332458	PD2K Proportioner Installation Manual, Automatic Systems
332564	PD2K Proportioner Operation Manual, Automatic Systems

Manual No.	Description
3A4186	PD2K Proportioner Dual Fluid Panel Operation Manual, Manual Systems
3A4486	PD2K Proportioner Dual Fluid Panel Operation Manual, Automatic Systems
332339	Pump Repair-Parts Manual
332454	Color Change Valve Repair-Parts Manual
332455	Color Change Kits Instructions-Parts Manual

Models

Kit Part No.	Series	Description	Maximum Fluid Working Pressure
24R968	A	70 cc Low Pressure Color Pump Kit	300 psi (2.068 MPa, 20.68 bar)
24R969	A	70 cc High Pressure Color Pump Kit	1500 psi (10.34 MPa, 103.4 bar)
24R970	A	35 cc Low Pressure Color or Catalyst Pump Kit	300 psi (2.068 MPa, 20.68 bar)
24R971	A	35 cc High Pressure Color or Catalyst Pump Kit	1500 psi (10.34 MPa, 103.4 bar)
24M268	A	35 cc Low Pressure Acid Catalyst Pump Kit	300 psi (2.068 MPa, 20.68 bar)
26A048	A	35 cc High Pressure Acid Catalyst Pump Kit	1500 psi (10.34 MPa, 103.4 bar)

ProMix® PD2K/PD1K				EXPANSION PUMP		
PART NO.	SERIES	SERIAL	MFG. YR.	MAX AIR WPR		
				.7	7	100
				MPa	bar	PSI
				MAX FLUID WPR		
				10.34	103.4	1500
				MPa	bar	PSI

 GRACO INC.
 P.O. Box 1441
 Minneapolis, MN
 55440 U.S.A.







MAX TEMP
 50°C (122°F)

Artwork No. 294116 Rev. C

Figure 1 . Pump Expansion Kit Identification Label

Warnings

The following warnings are for the setup, use, grounding, maintenance, and repair of this equipment. The exclamation point symbol alerts you to a general warning and the hazard symbols refer to procedure-specific risks. When these symbols appear in the body of this manual or on warning labels, refer back to these Warnings. Product-specific hazard symbols and warnings not covered in this section may appear throughout the body of this manual where applicable.

 <h2 style="margin: 0;">WARNING</h2>	
	<p>FIRE AND EXPLOSION HAZARD</p> <p>Flammable fumes, such as solvent and paint fumes, in work area can ignite or explode. To help prevent fire and explosion:</p> <ul style="list-style-type: none"> • Use equipment only in well ventilated area. • Eliminate all ignition sources; such as pilot lights, cigarettes, portable electric lamps, and plastic drop cloths (potential static arc). • Keep work area free of debris, including solvent, rags and gasoline. • Do not plug or unplug power cords, or turn power or light switches on or off when flammable fumes are present. • Ground all equipment in the work area. See Grounding instructions. • Use only grounded hoses. • Hold gun firmly to side of grounded pail when triggering into pail. Do not use pail liners unless they are antistatic or conductive. • Stop operation immediately if static sparking occurs or you feel a shock, Do not use equipment until you identify and correct the problem. • Keep a working fire extinguisher in the work area.
	<p>SKIN INJECTION HAZARD</p> <p>High-pressure fluid from gun, hose leaks, or ruptured components will pierce skin. This may look like just a cut, but it is a serious injury that can result in amputation. Get immediate surgical treatment.</p> <ul style="list-style-type: none"> • Do not spray without tip guard and trigger guard installed. • Engage trigger lock when not spraying. • Do not point gun at anyone or at any part of the body. • Do not put your hand over the spray tip. • Do not stop or deflect leaks with your hand, body, glove, or rag. • Follow the Pressure Relief Procedure when you stop spraying/dispensing and before cleaning, checking, or servicing equipment. • Tighten all fluid connections before operating the equipment. • Check hoses and couplings daily. Replace worn or damaged parts immediately.
	<p>MOVING PARTS HAZARD</p> <p>Moving parts can pinch, cut or amputate fingers and other body parts.</p> <ul style="list-style-type: none"> • Keep clear of moving parts. • Do not operate equipment with protective guards or covers removed. • Pressurized equipment can start without warning. Before checking, moving, or servicing equipment, follow the Pressure Relief Procedure and disconnect all power sources.
	<p>TOXIC FLUID OR FUMES</p> <p>Toxic fluids or fumes can cause serious injury or death if splashed in the eyes or on skin, inhaled, or swallowed.</p> <ul style="list-style-type: none"> • Read MSDSs to know the specific hazards of the fluids you are using. • Store hazardous fluid in approved containers, and dispose of it according to applicable guidelines. • Always wear chemically impermeable gloves when spraying, dispensing, or cleaning equipment.



WARNING



PERSONAL PROTECTIVE EQUIPMENT

Wear appropriate protective equipment when in the work area to help prevent serious injury, including eye injury, hearing loss, inhalation of toxic fumes, and burns. This protective equipment includes but is not limited to:

- Protective eyewear, and hearing protection.
- Respirators, protective clothing, and gloves as recommended by the fluid and solvent manufacturer.



EQUIPMENT MISUSE HAZARD

Misuse can cause death or serious injury.





- Do not operate the unit when fatigued or under the influence of drugs or alcohol.
- Do not exceed the maximum working pressure or temperature rating of the lowest rated system component. See **Technical Data** in all equipment manuals.
- Use fluids and solvents that are compatible with equipment wetted parts. See **Technical Data** in all equipment manuals. Read fluid and solvent manufacturer's warnings. For complete information about your material, request MSDS from distributor or retailer.
- Do not leave the work area while equipment is energized or under pressure.
- Turn off all equipment and follow the **Pressure Relief Procedure** when equipment is not in use.
- Check equipment daily. Repair or replace worn or damaged parts immediately with genuine manufacturer's replacement parts only.
- Do not alter or modify equipment. Alterations or modifications may void agency approvals and create safety hazards.
- Make sure all equipment is rated and approved for the environment in which you are using it.
- Use equipment only for its intended purpose. Call your distributor for information.
- Route hoses and cables away from traffic areas, sharp edges, moving parts, and hot surfaces.
- Do not kink or over bend hoses or use hoses to pull equipment.
- Keep children and animals away from work area.
- Comply with all applicable safety regulations.

Important Isocyanate (ISO) Information

Isocyanates (ISO) are catalysts used in two component materials.

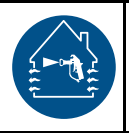

Isocyanate Conditions

				
---	---	---	---	--

Spraying or dispensing fluids that contain isocyanates creates potentially harmful mists, vapors, and atomized particulates



- Read and understand the fluid manufacturer's warnings and Safety Data Sheet (SDS) to know specific hazards and precautions related to isocyanates.
- Use of isocyanates involves potentially hazardous procedures. Do not spray with the equipment unless you are trained, qualified, and have read and understood the information in this manual and in the fluid manufacturer's application instructions and SDS.
- Use of incorrectly maintained or mis-adjusted equipment may result in improperly cured material. Equipment must be carefully maintained and adjusted according to instructions in the manual.
- To prevent inhalation of isocyanate mists, vapors, and atomized particulates, everyone in the work area must wear appropriate respiratory protection. Always wear a properly fitting respirator, which may include a supplied-air respirator. Ventilate the work area according to instructions in the fluid manufacturer's SDS.
- Avoid all skin contact with isocyanates. Everyone in the work area must wear chemically impermeable gloves, protective clothing and foot coverings as recommended by the fluid manufacturer and local regulatory authority. Follow all fluid manufacturer recommendations, including those regarding handling of contaminated clothing. After spraying, wash hands and face before eating or drinking.

Material Self-ignition

				
---	---	--	--	--

Some materials may become self-igniting if applied too thick. Read material manufacturer's warnings and material MSDS.

Keep Components A and B Separate

				
---	--	---	--	--

Cross-contamination can result in cured material in fluid lines which could cause serious injury or damage equipment. To prevent cross-contamination:

- **Never** interchange component A and component B wetted parts.
- Never use solvent on one side if it has been contaminated from the other side.

Moisture Sensitivity of Isocyanates

Exposure to moisture (such as humidity) will cause ISO to partially cure; forming small, hard, abrasive crystals, which become suspended in the fluid. Eventually a film will form on the surface and the ISO will begin to gel, increasing in viscosity.

NOTICE

Partially cured ISO will reduce performance and the life of all wetted parts.

- Always use a sealed container with a desiccant dryer in the vent, or a nitrogen atmosphere. **Never** store ISO in an open container.
- Keep the ISO pump wet cup or reservoir (if installed) filled with appropriate lubricant. The lubricant creates a barrier between the ISO and the atmosphere.
- Use only moisture-proof hoses compatible with ISO.
- Never use reclaimed solvents, which may contain moisture. Always keep solvent containers closed when not in use.
- Always lubricate threaded parts with an appropriate lubricant when reassembling.

NOTE: The amount of film formation and rate of crystallization varies depending on the blend of ISO, the humidity, and the temperature.

Changing Materials

NOTICE

Changing the material types used in your equipment requires special attention to avoid equipment damage and downtime.

- When changing materials, flush the equipment multiple times to ensure it is thoroughly clean.
- Always clean the fluid inlet strainers after flushing.
- Check with your material manufacturer for chemical compatibility.
- When changing between epoxies and urethanes or polyureas, disassemble and clean all fluid components and change hoses. Epoxies often have amines on the B (hardener) side. Polyureas often have amines on the A (resin) side.

Important Acid Catalyst Information

Pump Expansion Kit 26A048 is designed for acid catalysts (“acid”) currently used in two-component, wood-finishing materials. Current acids in use (with pH levels as low as 1) are more corrosive than earlier acids. More corrosion-resistant wetted materials of construction are required, and must be used without substitution, to withstand the increased corrosive properties of these acids.

Acid Catalyst Conditions

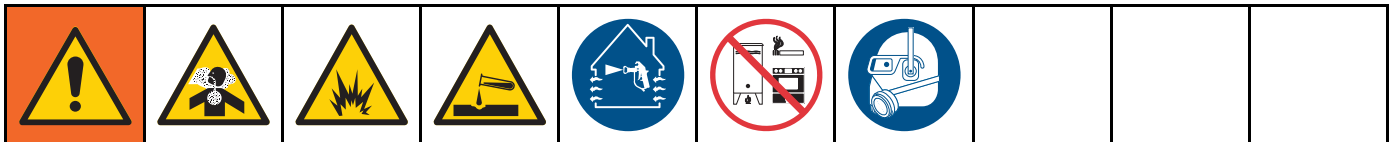

Acid is flammable, and spraying or dispensing acid creates potentially harmful mists, vapors, and atomized particulates. To help prevent fire and explosion and serious injury:

- Read and understand the acid manufacturer’s warnings and Safety Data Sheet (SDS) to know specific hazards and precautions related to the acid.
- Use only genuine, manufacturer’s recommended acid-compatible parts in the catalyst system (hoses, fittings, etc). A reaction may occur between any substituted parts and the acid.
- To prevent inhalation of acid mists, vapors, and atomized particulates, everyone in the work area must wear appropriate respiratory protection. Always wear a properly fitting respirator, which may include a supplied-air respirator. Ventilate the work area according to instructions in the acid manufacturer’s SDS.
- Avoid all skin contact with acid. Everyone in the work area must wear chemically impermeable gloves, protective clothing, foot coverings, aprons, and face shields as recommended by the acid manufacturer and local regulatory authority. Follow all acid manufacturer recommendations, including those regarding handling of contaminated clothing. Wash hands and face before eating or drinking.
- Regularly inspect equipment for potential leaks and remove spills promptly and completely to avoid direct contact or inhalation of the acid and its vapors.
- Keep acid away from heat, sparks, and open flames. Do not smoke in the work area. Eliminate all ignition sources.
- Store acid in the original container in a cool, dry, and well-ventilated area away from direct sunlight and away from other chemicals in accordance with acid manufacturer’s recommendations. To avoid corrosion of containers, do not store acid in substitute containers. Reseal the original container to prevent vapors from contaminating the storage space and surrounding facility.

Moisture Sensitivity of Acid Catalysts

Acid catalysts can be sensitive to atmospheric moisture and other contaminants. It is recommended the catalyst pump and valve seal areas exposed to atmosphere are flooded with ISO oil, TSL, or other compatible material to prevent acid build-up and premature seal damage and failure.



NOTICE

Acid build-up will damage the valve seals and reduce the performance and life of the catalyst pump. To prevent exposing acid to moisture:

- Always use a sealed container with a desiccant dryer in the vent, or a nitrogen atmosphere. Never store acids in an open container.
- Keep the catalyst pump and the valve seals filled with the appropriate lubricant. The lubricant creates a barrier between the acid and the atmosphere.
- Use only moisture-proof hoses compatible with acids.
- Always lubricate threaded parts with an appropriate lubricant when reassembling.

Installation

Before Installing the Kit

				
---	---	---	--	--





- Servicing the electrical control box exposes you to high voltage. To avoid electric shock, turn off power at the main circuit breaker before opening the enclosure.
- All electrical wiring must be done by a qualified electrician and comply with all local codes and regulations.
- Do not substitute or modify system components as this may impair intrinsic safety.

1. Flush the system as explained in your PD2K Operation Manual. Follow the Pressure Relief Procedure in your PD2K manual.
2. Close the main air shutoff valve on the air supply line.
3. Remove electrical power from the system.

NOTE: The pump expansion kit can be mounted directly on the PD2K stand, or mounted onto a wall. Install using the steps in [Install the Frame, page 10](#) or the steps in [Install the Wall Bracket, page 11](#).



Follow the Pressure Relief Procedure in your PD2K manual whenever you see this symbol.

				
--	--	--	--	--

This equipment stays pressurized until pressure is manually relieved. To help prevent serious injury from pressurized fluid such as skin injection, splashing fluid, and moving parts, follow the **Pressure Relief Procedure** in your system manual when you stop spraying and before cleaning, checking, or servicing the equipment.

Install the Frame

Use these steps if you want to install the kit onto the PD2K stand using frame (13).

1. Follow the steps in [Before Installing the Kit, page 9](#).
2. Install the frame (13) to the upright of the PD2K stand (A) using three screws (16) and nuts (18).
3. Install the back panel/bracket assembly (B) in the outermost position on the frame (13), to allow clearance for the color change manifold (C). Fasten the panel to the frame (13) using four screws (15) and nuts (18). Install the top screws from the front and the bottom screws from the back.

NOTE: The illustration shows a resin (70cc) pump expansion kit being installed on the left (color) side of the PD2K proportioner. The pump control module and dual grommet (11) are preassembled at the factory so the cable (8) is facing to the right, allowing easier access to connections inside the PD2K electrical control box (D).

Install a catalyst (35cc) pump expansion kit on the right side of the proportioner, with the pump control module and dual grommet (11) preassembled in the opposite direction so the cable (8) is facing to the left.

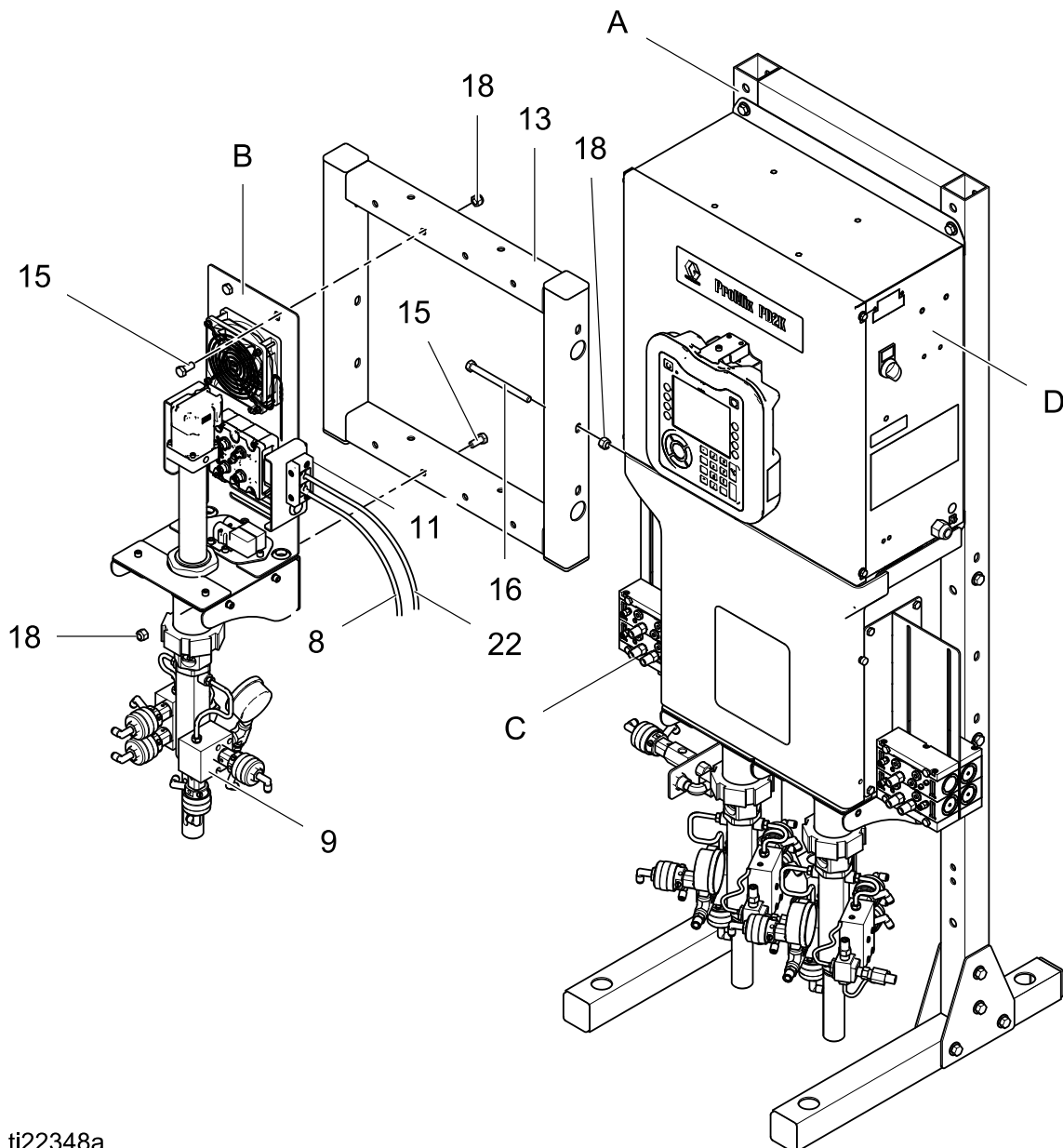

ti22348a

Figure 2 Install the Frame and Pump

Install the Wall Bracket

Use these steps if you want to install the kit away from the PD2K or PD1K stand using wall bracket (47).

1. Follow the steps in [Before Installing the Kit, page 9](#).
2. Install wall bracket (47) to a wall or other suitable vertical surface using four screws or bolts (user provided).

3. Install the back panel/bracket assembly (B) to wall bracket (47) using six screws (15) and six nuts (18).

NOTE: The illustration shows a resin (70cc) pump expansion kit being installed on the left (color) side of the PD1K proportioner. The pump control module and dual grommet (11) are preassembled at the factory so the cable (8) is facing to the right, allowing easier access to connections inside the PD1K electrical control box (D).

Install a catalyst (35cc) pump expansion kit on the right side of the proportioner, with the pump control module and dual grommet (11) preassembled in the opposite direction so the cable (8) is facing to the left.

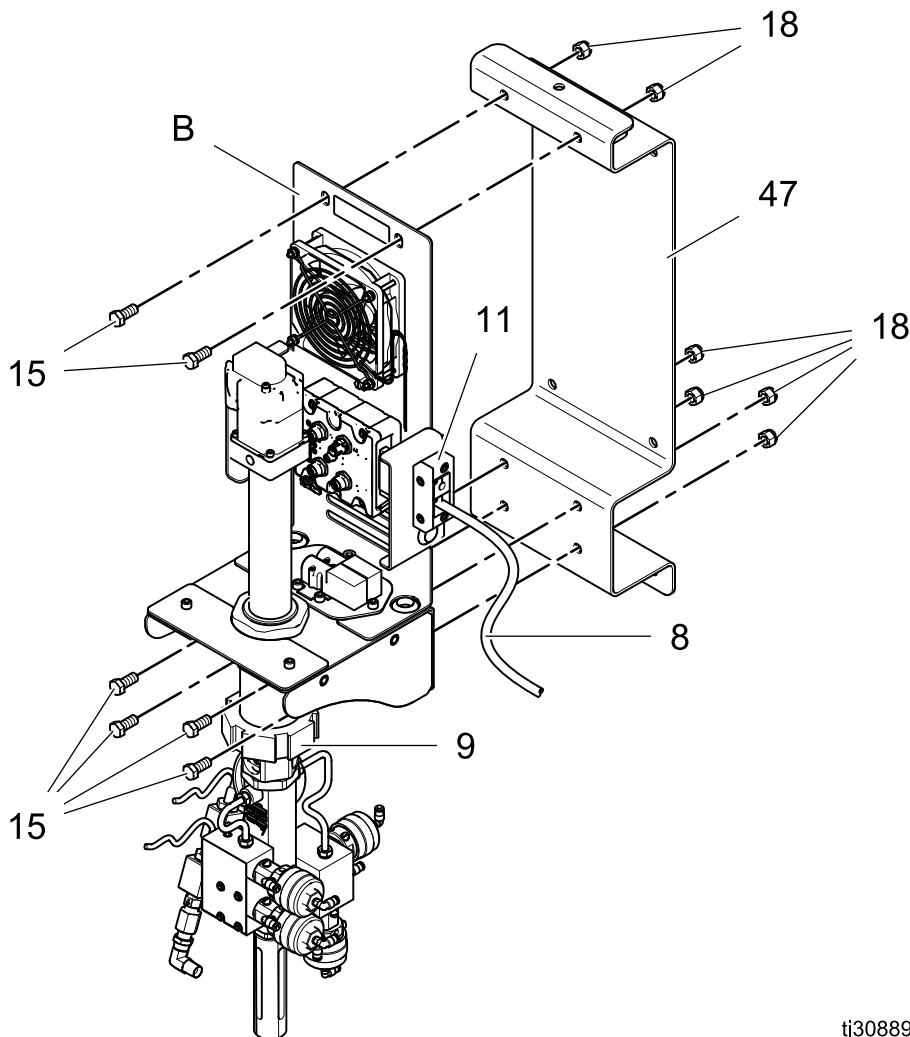

ti30889a

Figure 3 Install the Wall Bracket and Pump

TSL Cup Kit

The cup is used for either Throat Seal Liquid (TSL) or ISO oil. These liquids prevent exposure of air or moisture with the resin or catalyst at the pump throat packings and dosing valves. The PD2K Proportioner includes two TSL Cup Kits, one for each pump. The cups supply TSL to the upper throat cartridge of the color (70 cc) pump, to the upper and lower throat cartridges of the catalyst (35 cc) pump, and to the four pump dosing valves. When using isocyanate catalysts, the cup attached to the catalyst side of the PD2K Proportioner is used to supply ISO oil to the upper and lower throat cartridges of the catalyst (35 cc) pump and the catalyst dosing valves.

NOTE: TSL and ISO oil must be ordered separately. For TSL, order Part No. 206995, one quart (0.95 liter). For ISO oil, order Part No. 217374, one pint (0.48 liter).

1. Slide the kit mounting bracket onto any side of the pump's hex nut.

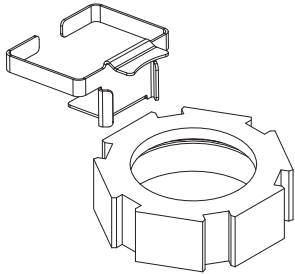

NOTE: Prior to mounting the cup, use a permanent black marker to mark a horizontal line on the front of the cup approximately half way between the top and bottom of the cup. Mark a second horizontal line approximately 1/4 in. (3 mm) above the first line. Shining a strong light towards these lines will provide a shadow that will be visible from inside the TSL cup.

2. Place the TSL cup (73) into the bracket (73a).

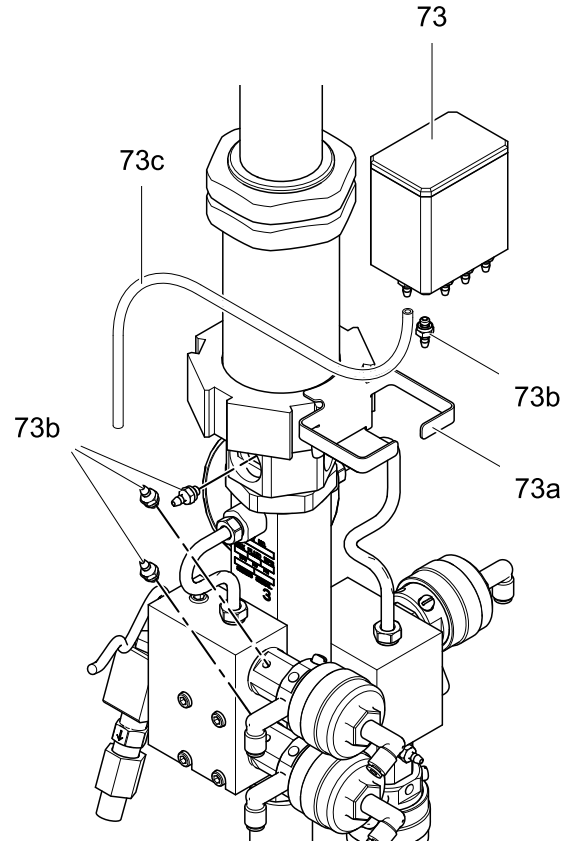
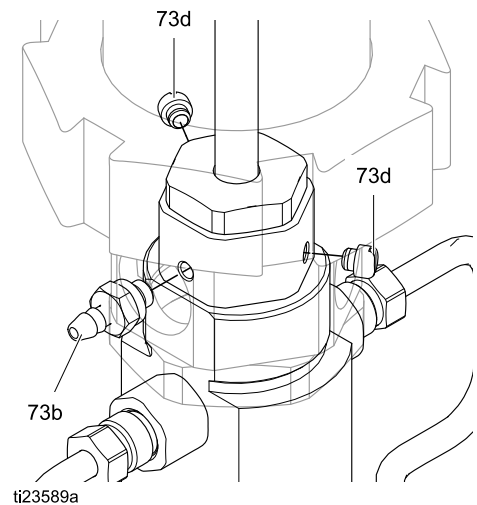

Figure 4 Install TSL Cup Kit

NOTE: The pump's upper throat cartridge has three ports (two are plugged). Move a plug (73d) if necessary so the barbed fitting (73b) can be put in the port closest to the TSL cup.

3. Check that the o-ring is in place on the barbed fitting (73b). Apply low strength thread adhesive and install the fitting in the upper throat cartridge port. Be sure the other two ports are plugged (73d).



ti23589a

- Catalyst (35 cc) pumps:** Repeat for the lower throat cartridge.

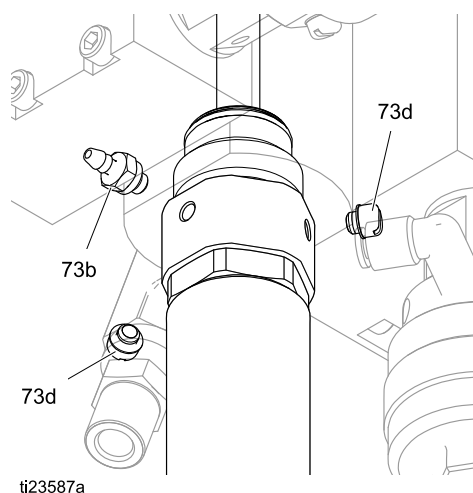

- If you are lubricating the dosing valves, remove the plug (73d) and gasket from the valve port (V) closest to the TSL cup.

NOTE: Choose the valve port in the upward facing position. This will allow liquid to flow into the valve while allowing air to rise out of the valve.

Check that the o-ring is in place on the barbed fitting (73b). Apply low strength thread adhesive and install the fitting in the valve port (V).

NOTE: Do not confuse the valve port (V) with the air port (W).

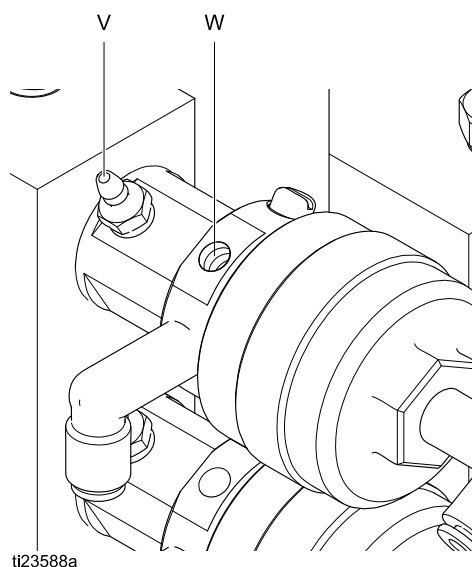

NOTE: If you are not lubricating the dosing valves, remove the unused barbed fittings (73b) from the bottom of the TSL cup (73). Apply low strength thread adhesive and install the plugs and gaskets supplied with the kit.

- Cut the tubing (73c) to length as required. Connect the TSL cup fittings to the fittings on the pump and valves. TSL is gravity-fed from the cup to the pump and valves; position the fittings and tubing to prevent kinks and enable the TSL to flow freely down to the valve and air to rise up and out of the valve.
- Fill the cup to the level of the lower black horizontal line with either TSL or ISO oil, as appropriate for the resin and catalyst materials being used.

NOTE: If TSL leaks from the rod guard of the color (70 cc) pump, be sure the lower u-cup seal is installed in the lower throat cartridge.

NOTE: The fluid levels in the TSL cups should be checked daily. Fluid levels should remain static for an extended period of time. Rising or falling fluid levels in a TSL cup can be an indication of a condition which needs immediate attention. Refer to the troubleshooting steps in the repair manual for guidance.

ISO Oil Fill Procedure

When using polyurethane coatings with isocyanate catalysts in high-humidity environments, use of ISO oil on the catalyst pump TSL cup is recommended instead of TSL. The ISO oil will present a barrier that will prevent catalyst hardening from contact with moisture. When performing the first fill of a cup with ISO oil, it will be necessary to bleed the air out of the feed line.

NOTE: If not already present on the TSL cup, draw the two horizontal lines at, and slightly above, the vertical center of the front of the cup before filling.

To bleed air:

- Fill the catalyst pump TSL cup to the lower horizontal line.
- Remove one plug (73d) from the upper throat cartridge and allow air in that area to flow until no air is being expelled. Replace the plug.
- Repeat step 2 at the lower throat cartridge.
- Use absorbent rags to clean up excess ISO oil that escaped from the plug holes.
- Replenish the ISO oil level in the TSL cup to the lower horizontal line.

Air Connections

For PD2K installations: Follow the steps below.

For PD1K installations: For the first expansion kit, connect the air supply tube (35) directly to the electrical control box (Z). For the second through fourth expansion kits, follow steps 2–4 below.

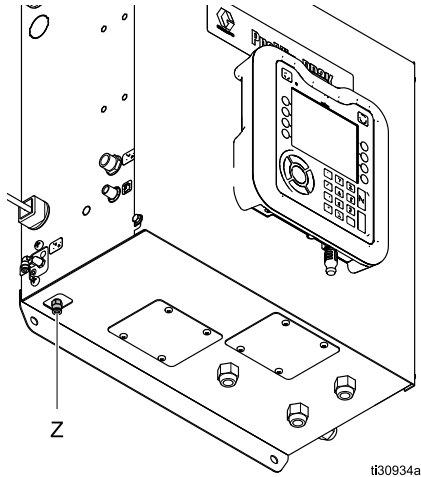

ti30934a

Figure 5 Air Connection for PD1K First Expansion Kit

NOTE: A 6 ft (1.83 m) length of 1/4 in. (6 mm) OD polyethylene tubing (35) is supplied with the kit to supply air to the expansion pump’s solenoid manifold (3).

1. See the PD2K Repair-Parts Manual. Remove the PD2K fluid panel cover to expose the air supply tubing to the two existing solenoid manifolds.
2. Cut the air supply tubing upstream of the Y-fitting.
3. Install the Y-fitting (36) supplied in the kit as shown, to restore the air supply to the two existing solenoid manifolds.
4. Connect the supplied 1/4 in. (6 mm) OD tubing (35) between the open branch of the Y-fitting (36) and the air inlet of the solenoid manifold (3). This supplies air to the expansion pump solenoid manifold, as shown in the detail of the illustration.

NOTE: If you are installing a fourth pump, make a second splice in the main solenoid air supply line and plumb as explained above.

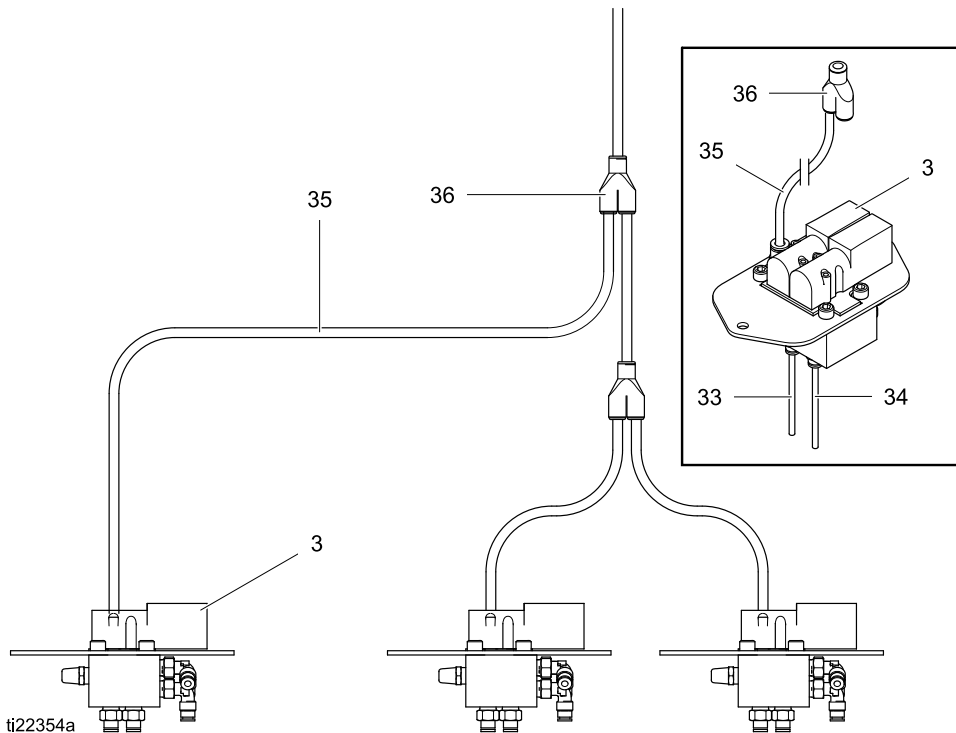

ti22354a

Figure 6 Supplying Air to the Expansion Pump Solenoid Manifold

Fluid Connections

1. Connect a 1/4 npt(f) fluid hose from the fluid source to the pump's fluid inlet fitting (S).
2. Connect a 1/4 npt(f) fluid outlet hose from the pump's fluid outlet fitting (R) to the gun's fluid supply.

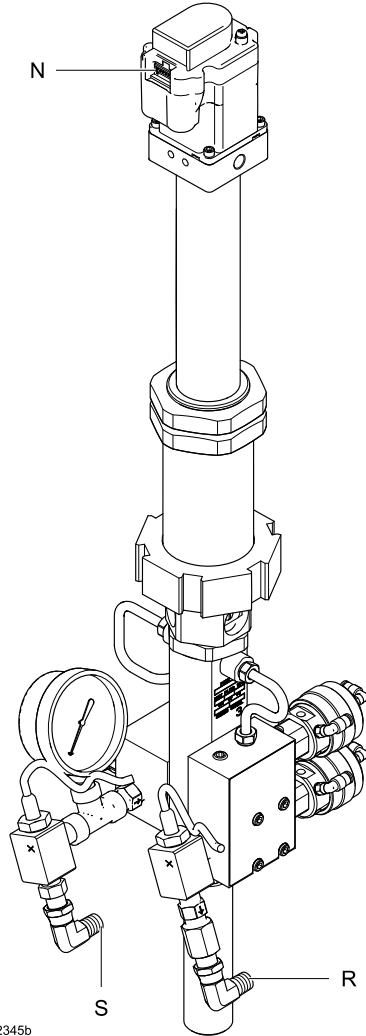

ti22345b

Figure 7 Pump Fluid Connections

Electrical Connections

NOTICE

To avoid electrical component damage, remove all system power before plugging any connectors.

NOTE: See the [Electrical Schematics, page 24](#).

1. Verify that electrical power is removed from the system.
2. Remove the cover from the PD2K/PD1K electrical control box.
3. Remove the knockout (K) from the side of the electrical control box.

4. Thread the cable into the electrical control box and connect to the appropriate connection port on the enhanced fluid control module. For example, connect Pump 1 to P1 and Pump 2 to P2 (PD1K only); Pump 3 to P3, Pump 4 to P4, and so on.

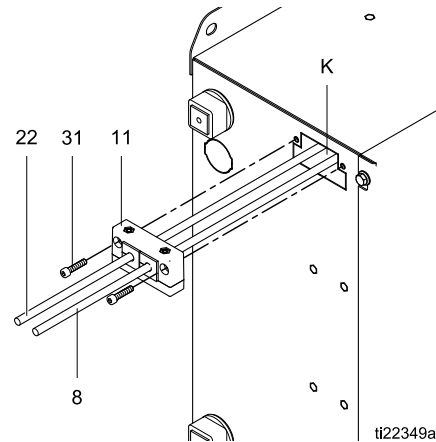

Figure 8 Install Grommet in Electrical Control Box

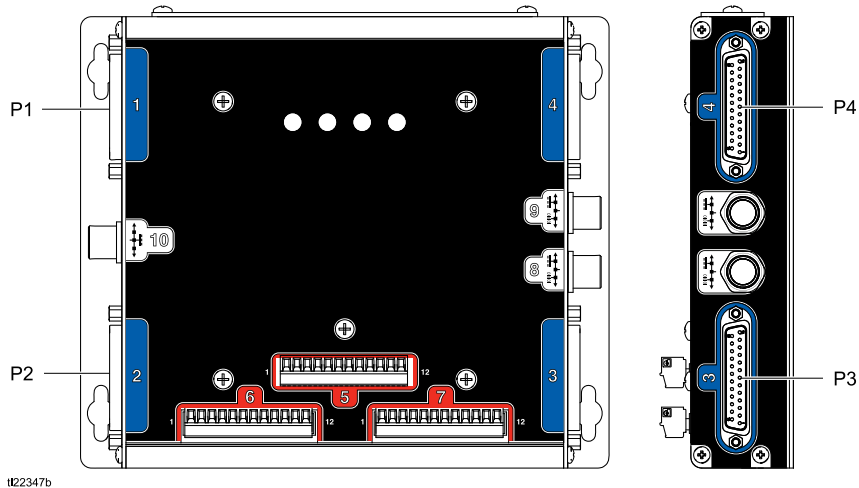
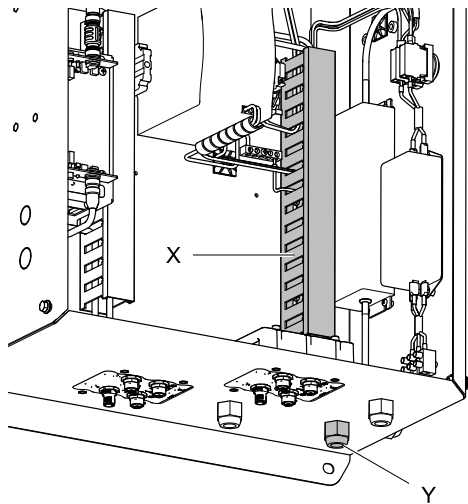

Figure 9 Enhanced Fluid Control Module Connection Points

NOTICE

Be sure to keep 48 volt cables isolated from the low voltage wiring. All 48 VDC wiring must use the right-hand wireway (X) inside the electrical control box. Use grommet (Y) marked in Figure 9 to install the Pump Expansion Kit wiring.



ti30905a

Figure 10 48 VDC Grommet and Wireway

- The PD2K/PD1K fluid panel cover was previously removed in [Air Connections, page 14](#). Thread the 2-wire cable (22) through the grommet (42) on the bottom of the fluid panel and up into the electrical box through an existing grommet and the wireway. Connect the cable (22) to the appropriate terminals on the top of the 48 VDC power supply: P1 for Pump 1 and P2 for Pump 2 (PD1K only); P3 for Pump 3, P4 for Pump 4. Connect the red wire to + terminal, black wire to - terminal.

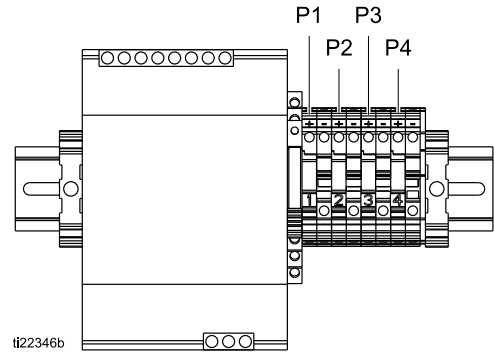





ti22346b

Figure 11 48 VDC Power Supply Connection Points

- Install the dual grommet (11, shipped loose) on the free end of the D-SUB cable (8).
- Fasten the grommet (11) to the side of the electrical control box, using two screws (31).
- Reinstall the covers on the PD2K electrical control box and on the fluid panel.

Grounding

				
<p>This equipment must be grounded to reduce the risk of static sparking and electric shock. Electric or static sparking can cause fumes to ignite or explode. Improper grounding can cause electric shock. Grounding provides an escape wire for the electric current.</p>				

1. Verify that the PD2K base unit is properly grounded. See the PD2K installation manual for complete grounding instructions.
2. Ground the expansion kit pump(s) as follows:
 - a. **If the added pump is mounted to the PD2K main unit**, verify that the added pump is grounded by taking a resistance reading from the ground screw (7) on the added pump kit's back panel (2) to the system's true earth ground. Resistance must be less than 1 ohm.
 - b. **If the added pump is NOT mounted to the PD2K main unit**, connect a ground wire to the ground screw (7) on the added pump kit's back panel (2). Connect the other end of the ground wire to the **same** true earth ground that the main PD2K unit is connected to. Verify that the added pump is grounded by taking a resistance reading from the ground screw (7) on the added pump kit's back panel (2) to the system's true earth ground. Resistance must be less than 1 ohm.

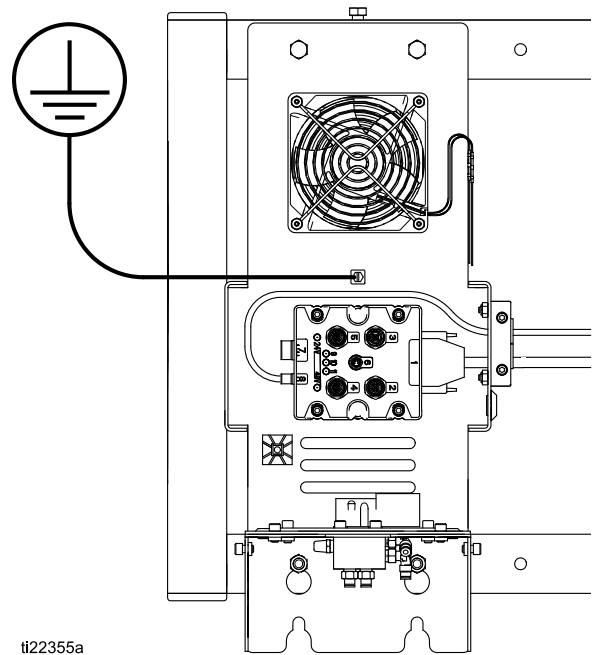

Figure 12 Grounding the Pump Expansion Kit

Complete the Installation

1. Install the cover (12) on the expansion kit, using the screw (37) and nut (18).

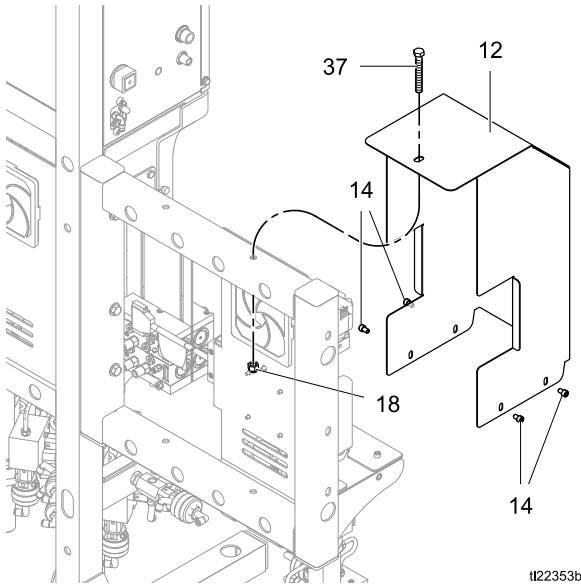

Figure 13 Install Expansion Kit Cover (Frame)

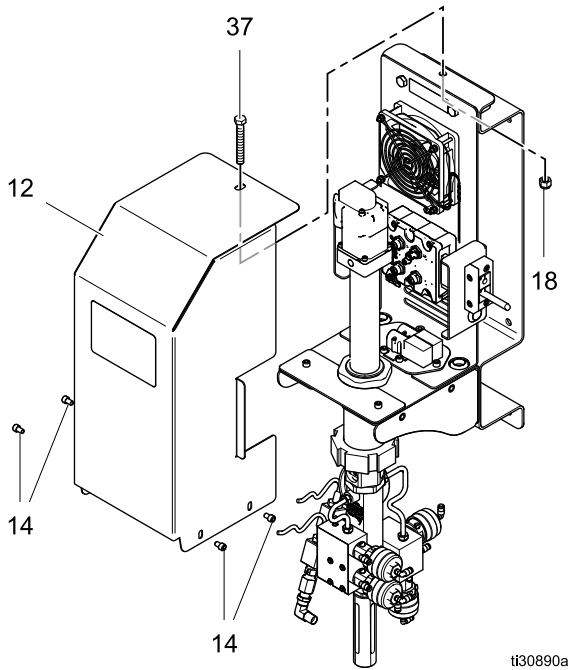



Figure 14 Install Expansion Kit Cover (Wall Mount)

2. Restore electrical power to the PD2K/PD1K.
3. Turn on the control box power switch.

4. Press  and navigate to System Screen 1 on the Advanced Display Module. Change the number of Color Pumps and Catalyst Pumps as needed, based on the kit installation.

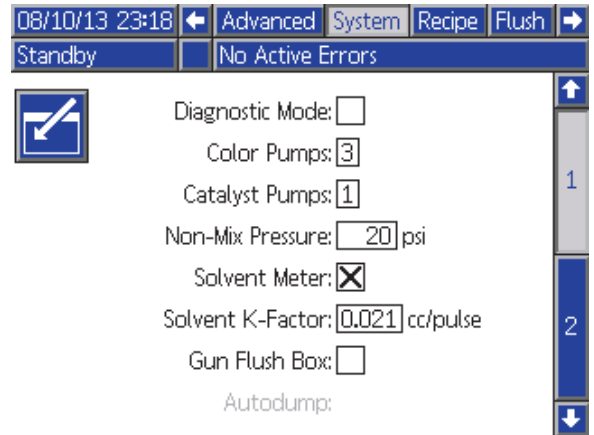

Figure 15 System Screen 1

Installation

- Go to the Pump Screens. The menu bar at the top of the screen will now show separate tabs for the added pump(s) 3 and 4. Each pump has three screens. Enter the required information, as explained in the PD2K Operation Manual.

NOTE: At a minimum, you must enter the Pump Size on Pump Screen 1 and transducer calibration data “Outlet Offset Factor” and “Outlet Sensitivity Factor” on Pump Screen 2 (see your PD2K Operation Manual). Also, create a recipe using the new material number, which can be found on Pump Screen 1 under Available Colors (or Catalysts).

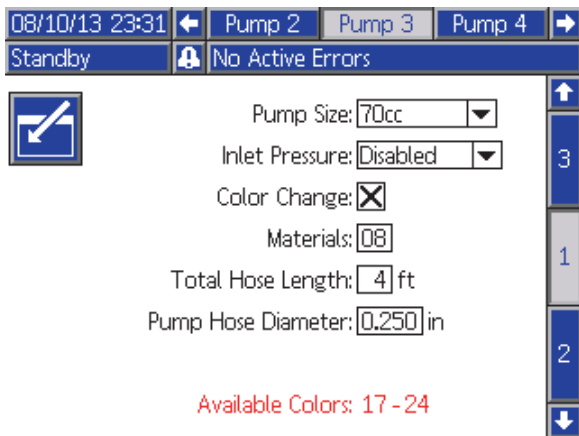

Figure 16 Third (Color) Pump Screen

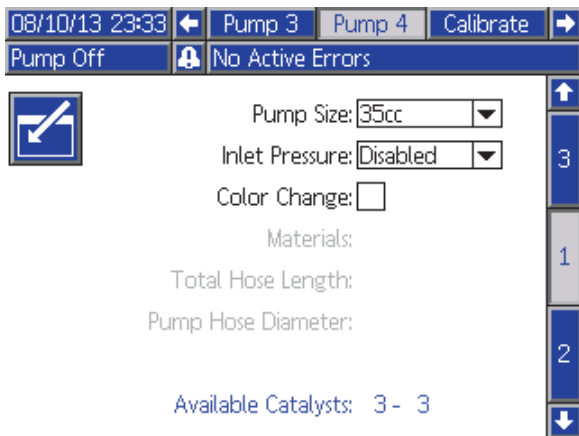

Figure 17 Fourth (Catalyst) Pump Screen

- The Home Screen will now show animations and information for the added pumps.

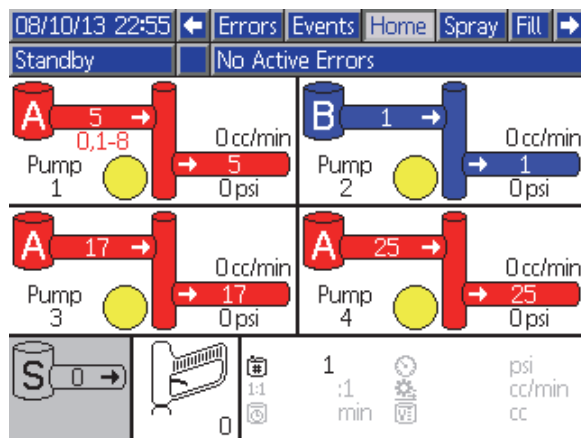

Figure 18 PD2K Home Screen (Advanced Display Module)

- See the PD2K Operation Manual to return the system to service.

Repair

Dose Valve Tubing Connections

NOTE: 5/32 in. (4 mm) tubing connects the solenoid manifold to the pump's dosing valves. See the Pump Tubing Schematic on the next page. Tubing lengths must be 18 in. \pm 1/2 in. (457 mm \pm 13 mm) for all connections. Always use equal lengths of tubing, to balance the timing of the valves. Lengths longer than 18 in. (457 mm) will increase valve response time.

1. On the bottom of the solenoid manifold are four ports with tube fittings: UP OPEN, UP CLOSED, DOWN OPEN, and DOWN CLOSED. These ports provide air to open and close the pump's inlet dosing valves.

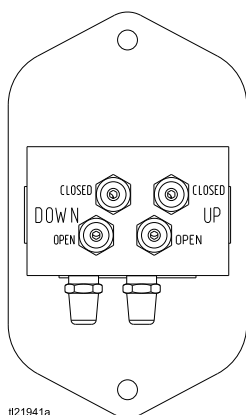

ti21941a

Figure 19 Tubing Connections at Solenoid Manifold, to Pump Inlet Manifold

- a. Connect green tubing (G) from the UP OPEN fitting to the 90° tube fitting on the side of the INLET UP dosing valve.
- b. Connect red tubing (R) from the UP CLOSED fitting to the 90° tube fitting on the end of the INLET UP dosing valve.
- c. Connect black tubing (K) from the DOWN OPEN fitting to the 90° tube fitting on the side of the INLET DOWN dosing valve.
- d. Connect red tubing (R) from the DOWN CLOSED fitting to the 90° tube fitting on the end of the INLET DOWN dosing valve.

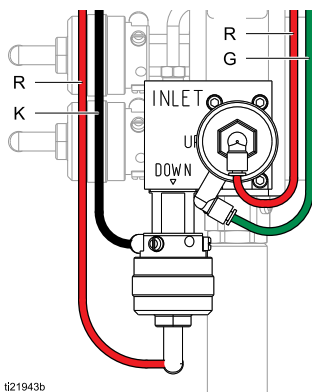

ti21943b

Figure 20 Inlet Manifold Tubing Connections

2. On the side of the solenoid manifold are four ports with 90° tube fittings (not shown): UP OPEN, UP CLOSED, DOWN OPEN, and DOWN CLOSED. These ports provide air to open and close the pump's outlet dosing valves.

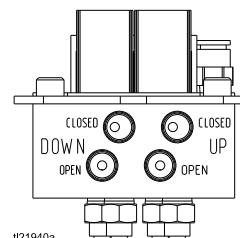

ti21940a

Figure 21 Tubing Connections at Solenoid Manifold, to Pump Outlet Manifold

- a. Connect blue tubing (B) from the UP OPEN fitting to the 90° tube fitting on the side of the OUTLET UP dosing valve.
- b. Connect red tubing (R) from the UP CLOSED fitting to the 90° tube fitting on the end of the OUTLET UP dosing valve.

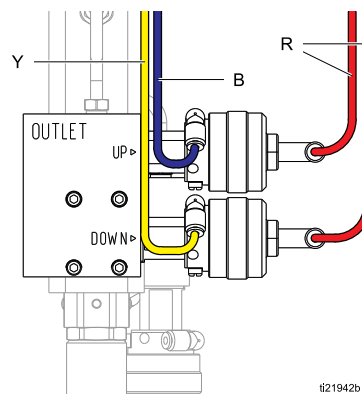

ti21942b

Figure 22 Outlet Manifold Tubing Connections

Repair

- c. Connect yellow tubing (Y) from the DOWN OPEN fitting to the 90° tube fitting on the side of the OUTLET DOWN dosing valve.
 - d. Connect red tubing (R) from the DOWN CLOSED fitting to the 90° tube fitting on the end of the OUTLET DOWN dosing valve.
3. Repeat these steps for each pump in your system.

See the following table to understand the relationship between pump stroke and dose valve actuation.

Table 1 Dose Valve Actuation

Pump Stroke	Up Inlet Valve	Down Inlet Valve	Up Outlet Valve	Down Outlet Valve
Up	Open	Closed	Open	Closed
Down	Closed	Open	Closed	Open

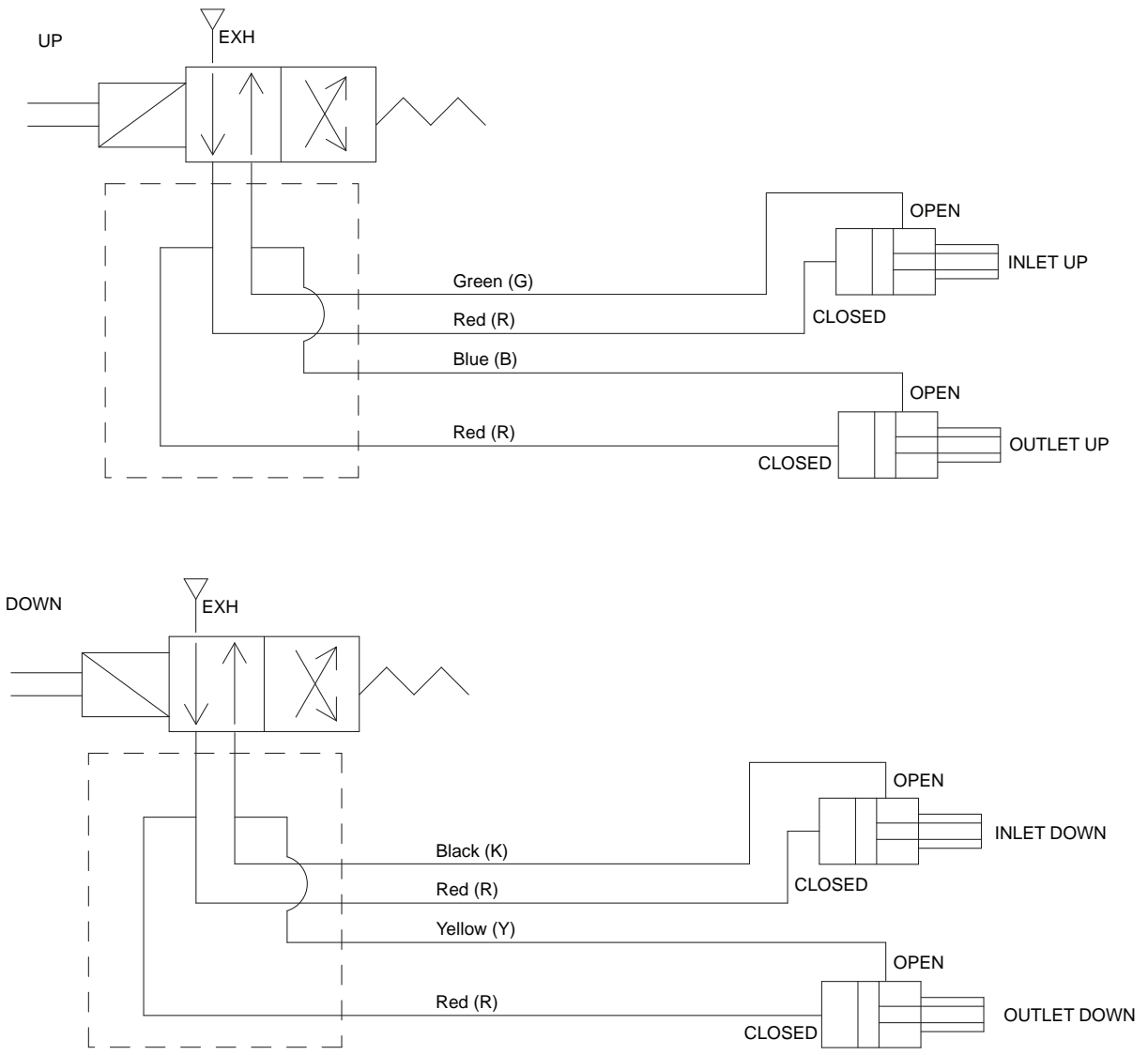

Figure 23 Pump Tubing Schematic

Replace Pump Control Module

If the pump control module needs replacement, install a new module as follows.

NOTICE

To avoid electrical component damage, remove all system power before plugging any connectors.

NOTE: See the [Electrical Schematics](#), page 24.

1. Connect the motor cable connectors (25) to connection ports 2 and 3 on the pump control module (5) and to the pump motor (N).

NOTE: The wire harness has two cables, one for the motor control and the other for encoder feedback. The connectors are keyed differently to ensure correct installation. Attach the two ground wires to the ground screw on the pump motor (N).

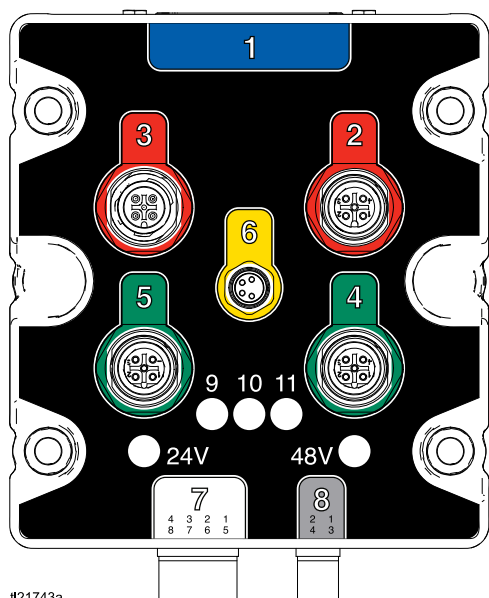

Figure 24 Pump Control Module Connection Points

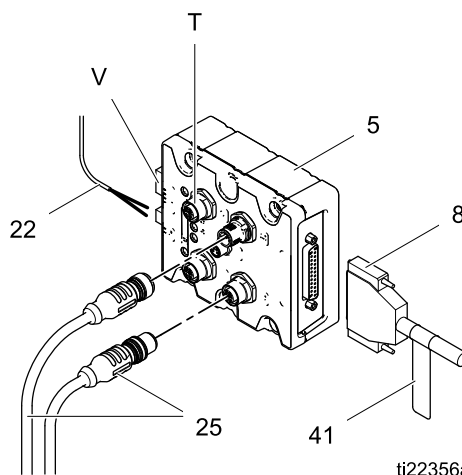

Figure 25 Pump Control Module Connections

2. Connect the 2-wire cable (22) to connection port 8 on the pump control module (5); red wire to pin 1 and black wire to pin 2.
3. Ensure that the pre-installed D-SUB Cable (8) is securely attached to connection port 1 on the pump control module (5).
4. Connect the pump's outlet pressure transducer (T) to port 5.
5. Connect the inlet pressure transducer to port 4.
6. Install the valve wiring (V) in port 7. See [Electrical Schematics](#), page 24.

Electrical Schematics

Standard Models (MC1000, MC2000, MC3000, MC4000)

NOTE: The electrical schematic illustrates all possible wiring expansions in a ProMix PD2K system; models MC1000, MC2000, and MC4000. Some components shown are not included with all systems.

NOTE: See [Optional Cables and Modules](#) for a list of cable options.

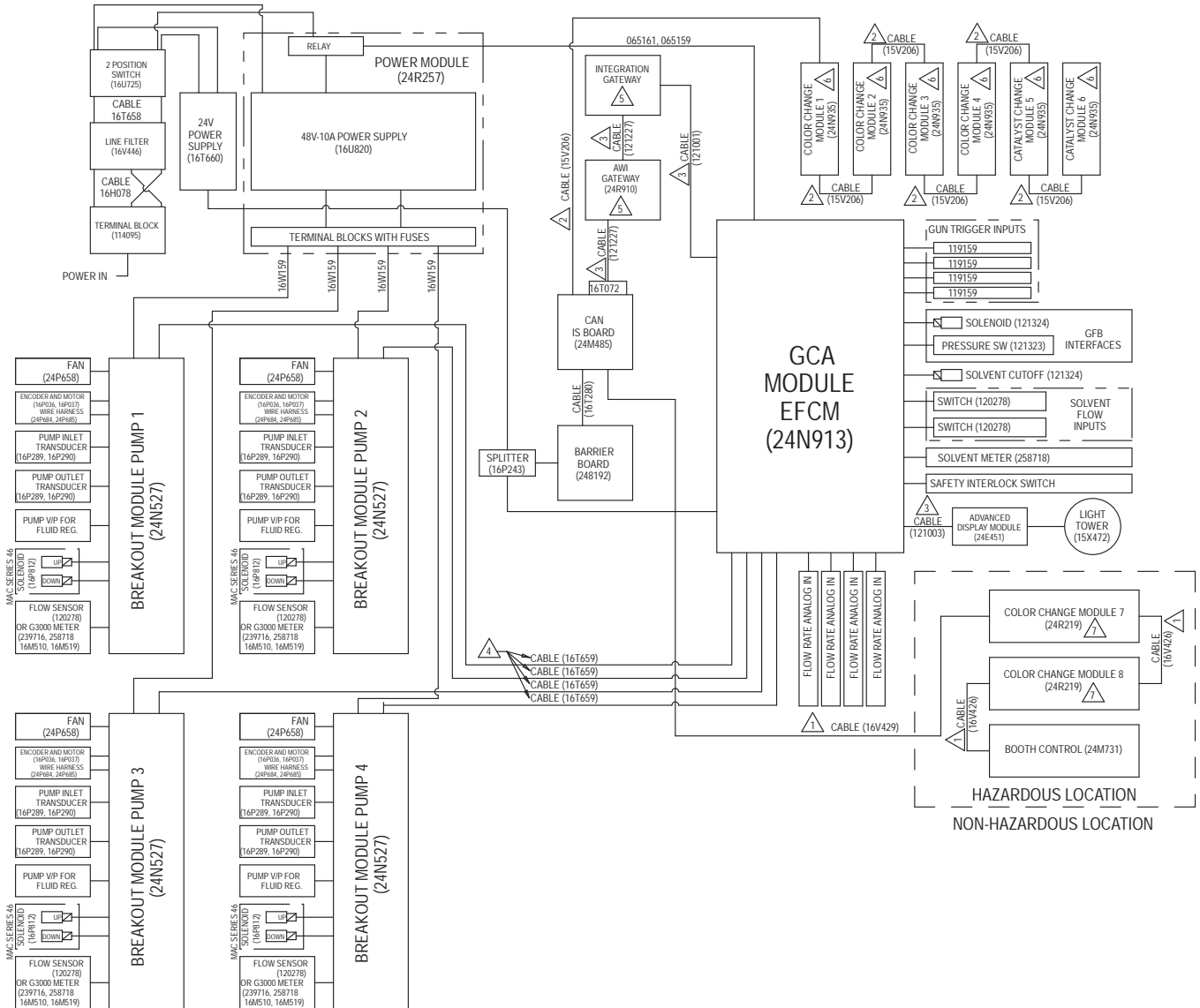

Figure 26 Electrical Schematic, Sheet 1

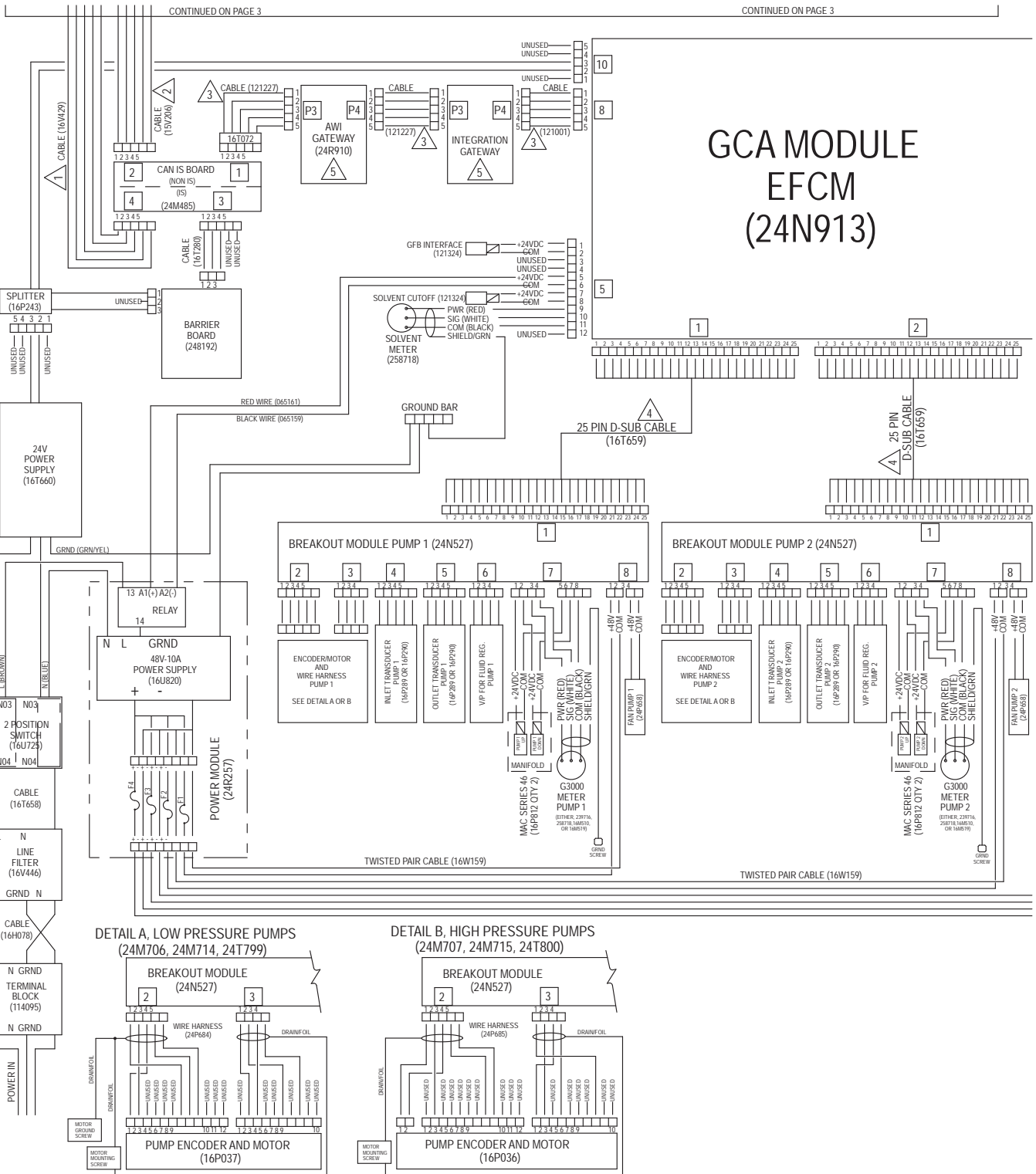

Figure 27 Electrical Schematic, Sheet 2, Part 1

CONTINUED ON THE NEXT PAGE

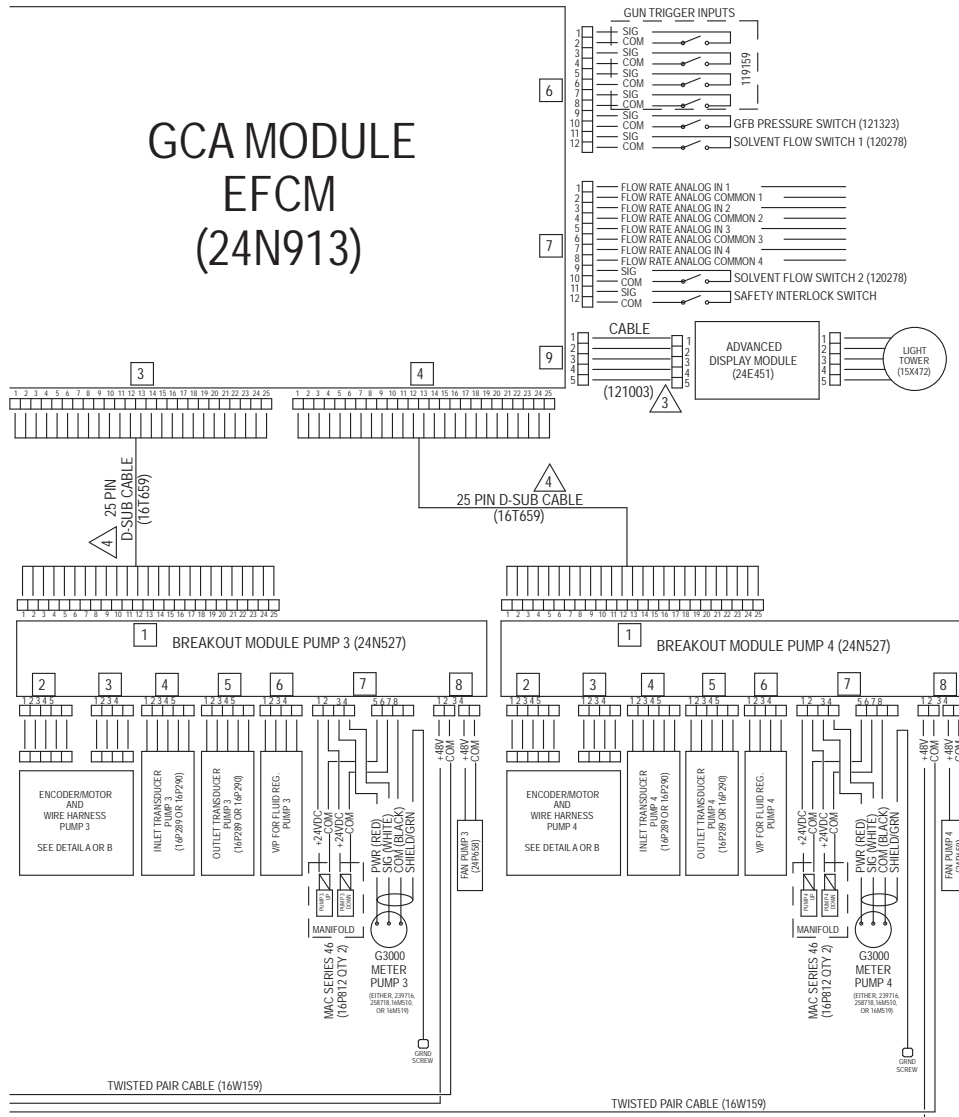

Figure 28 Electrical Schematic, Sheet 2, Part 2
CONTINUED ON THE NEXT PAGE

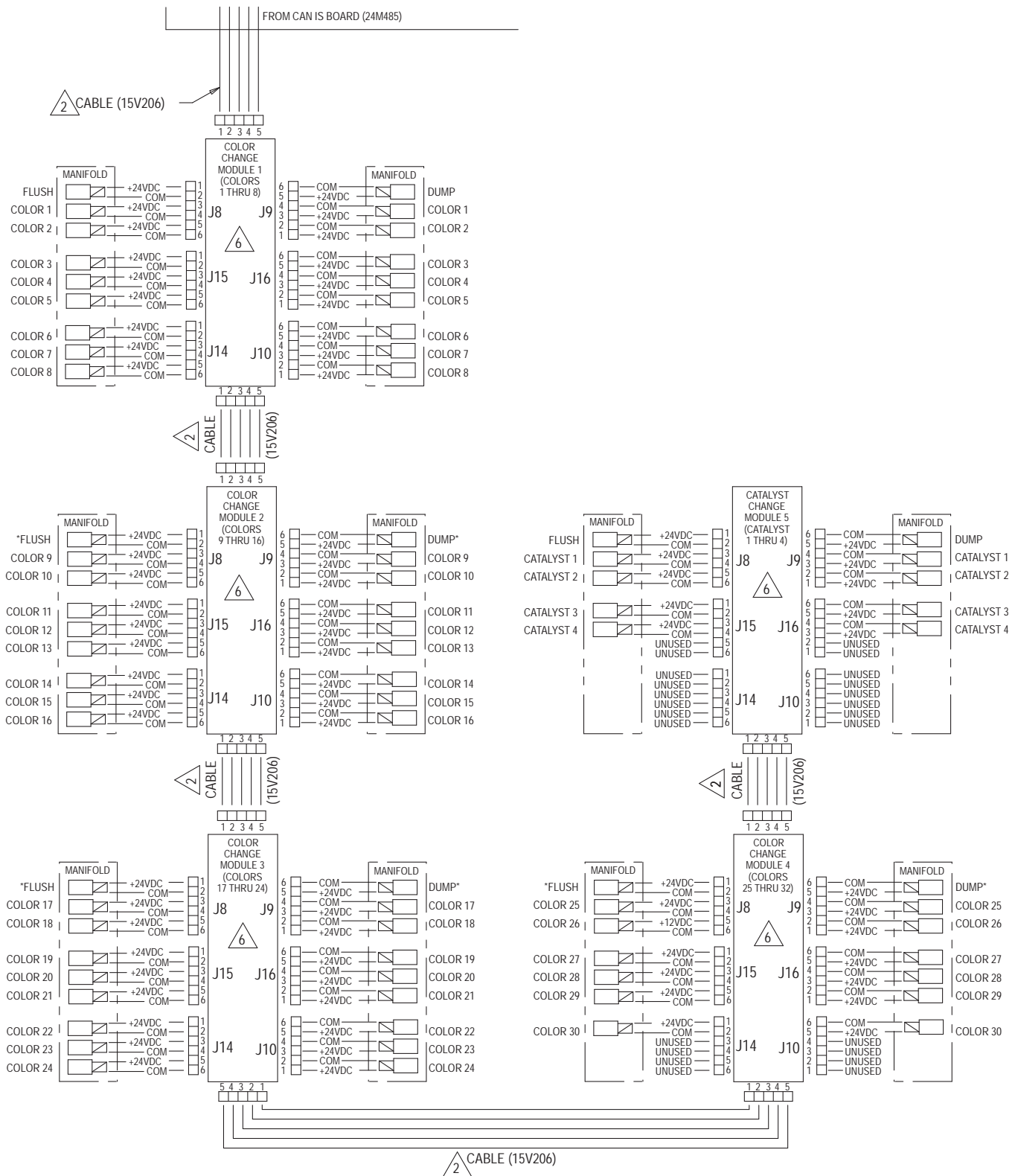
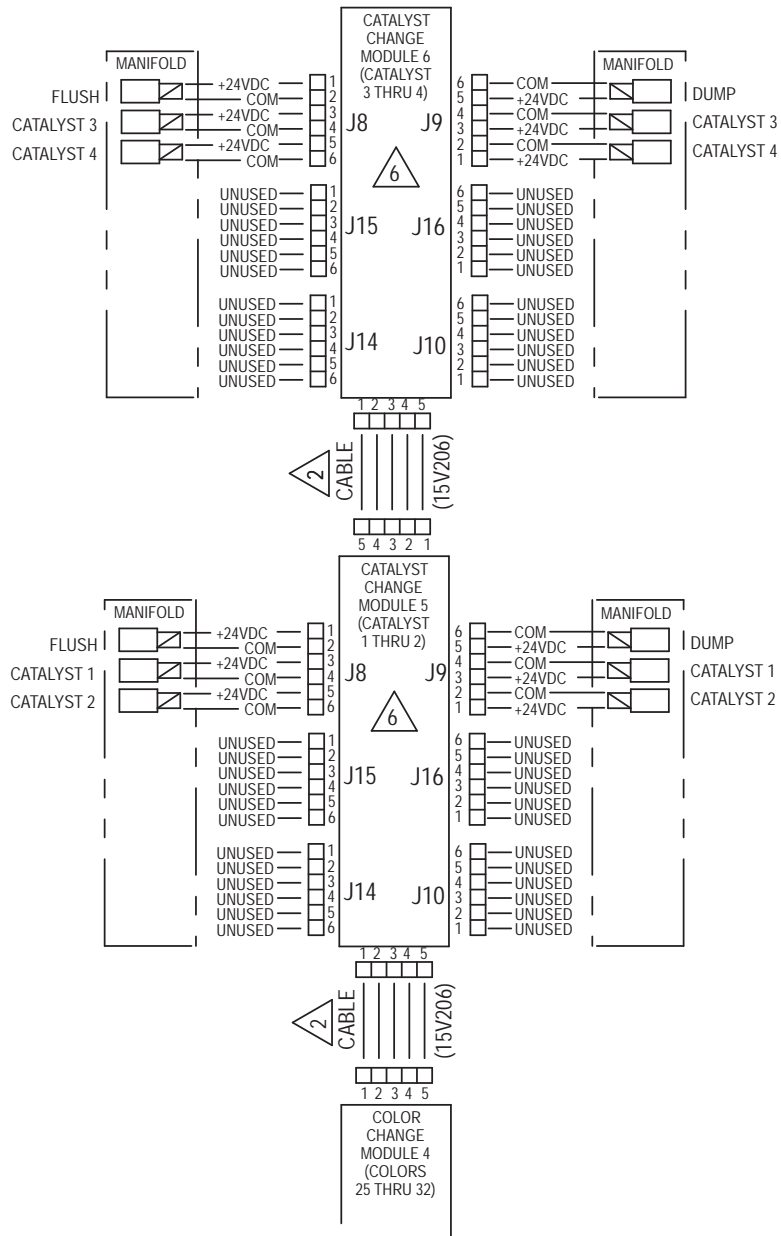

Figure 29 Electrical Schematic, Sheet 3

* May be unused in some configurations.

CONTINUED ON THE NEXT PAGE



ALTERNATE CONFIGURATION
FOR CATALYST CHANGE CONTROL

Figure 30 Electrical Schematic, Sheet 3, Alternate Configuration for Catalyst Change Control

CONTINUED ON THE NEXT PAGE

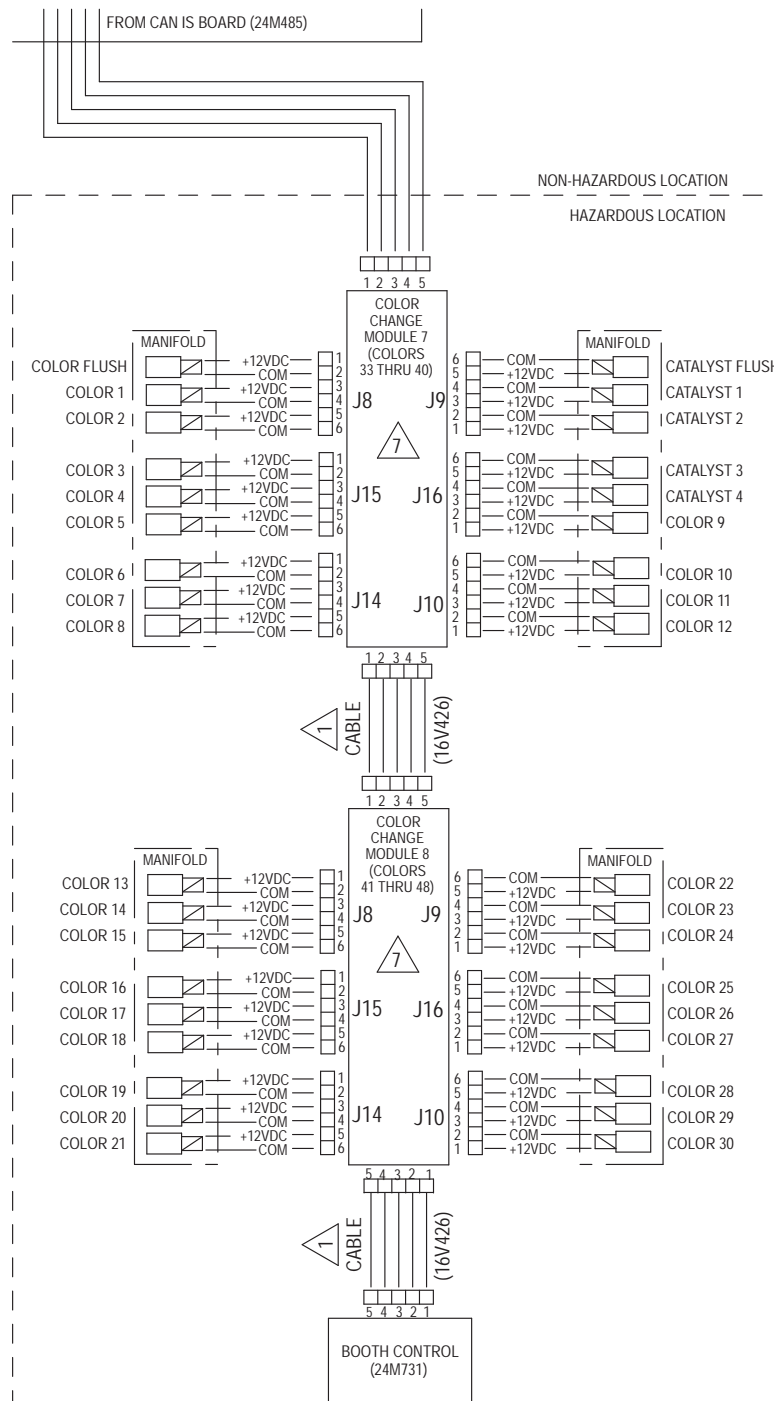

Figure 31 Electrical Schematic, Sheet 3, Hazardous Location

Dual Panel Models (MC1002, MC2002, MC4002)

NOTE:The electrical schematic illustrates all possible wiring expansions in a ProMix PD2K system; models MC1002, MC2002, and MC4002. Some components shown are not included with all systems.

NOTE: See [Optional Cables and Modules](#) for a list of cable options.

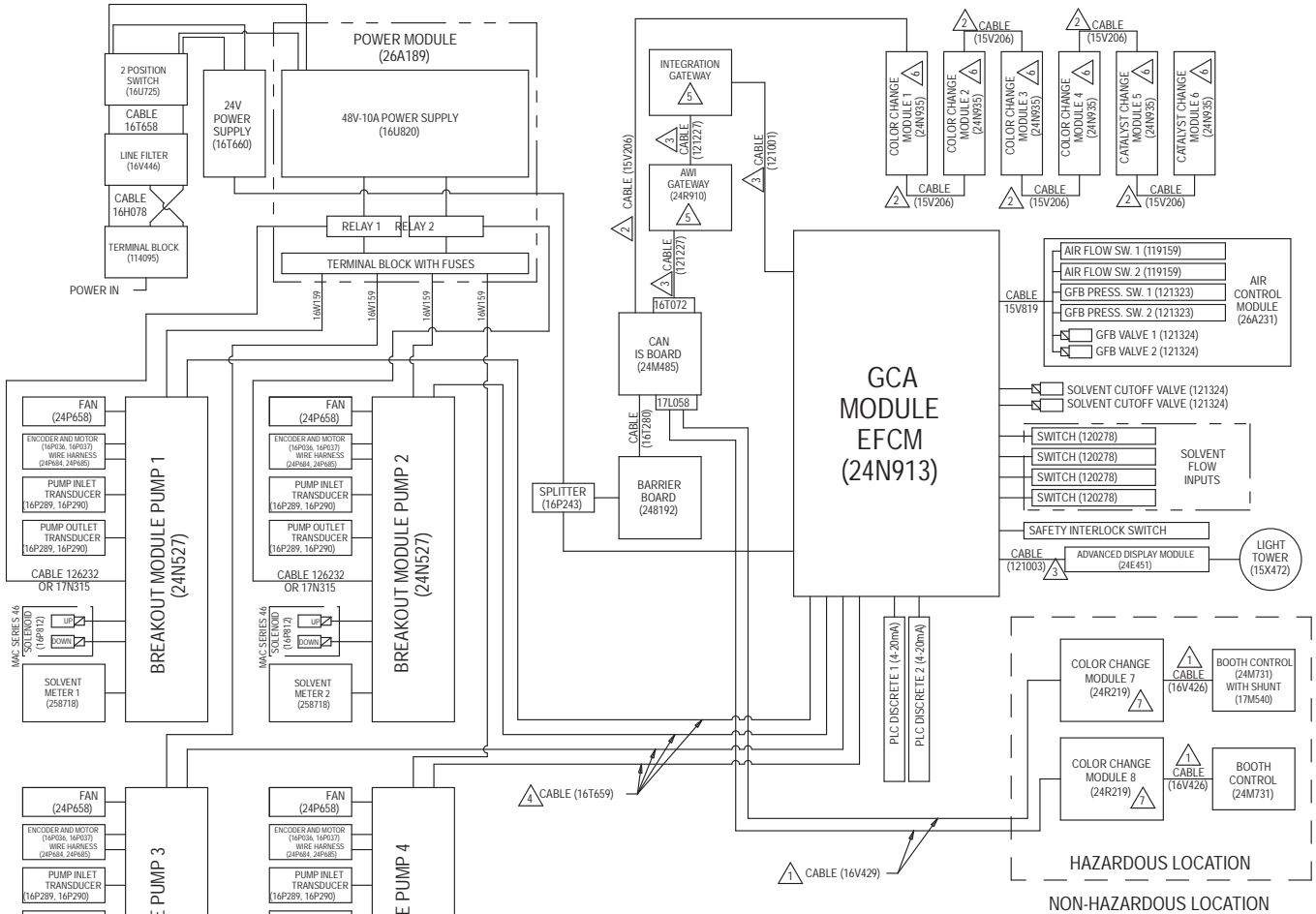

Figure 32 Electrical Schematic, Sheet 1

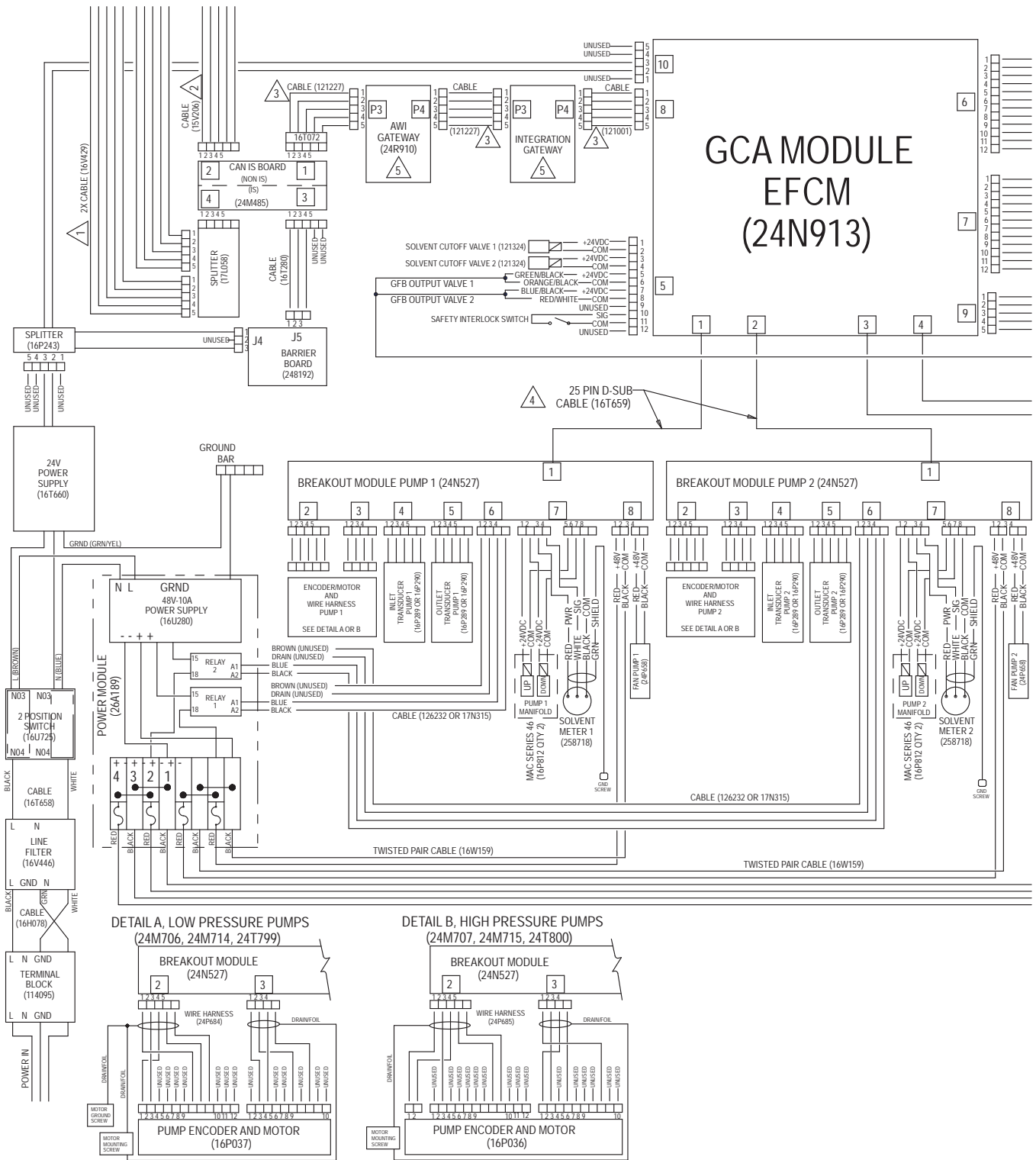

Figure 33 Electrical Schematic, Sheet 2, Part 1

CONTINUED ON THE NEXT PAGE

Electrical Schematics

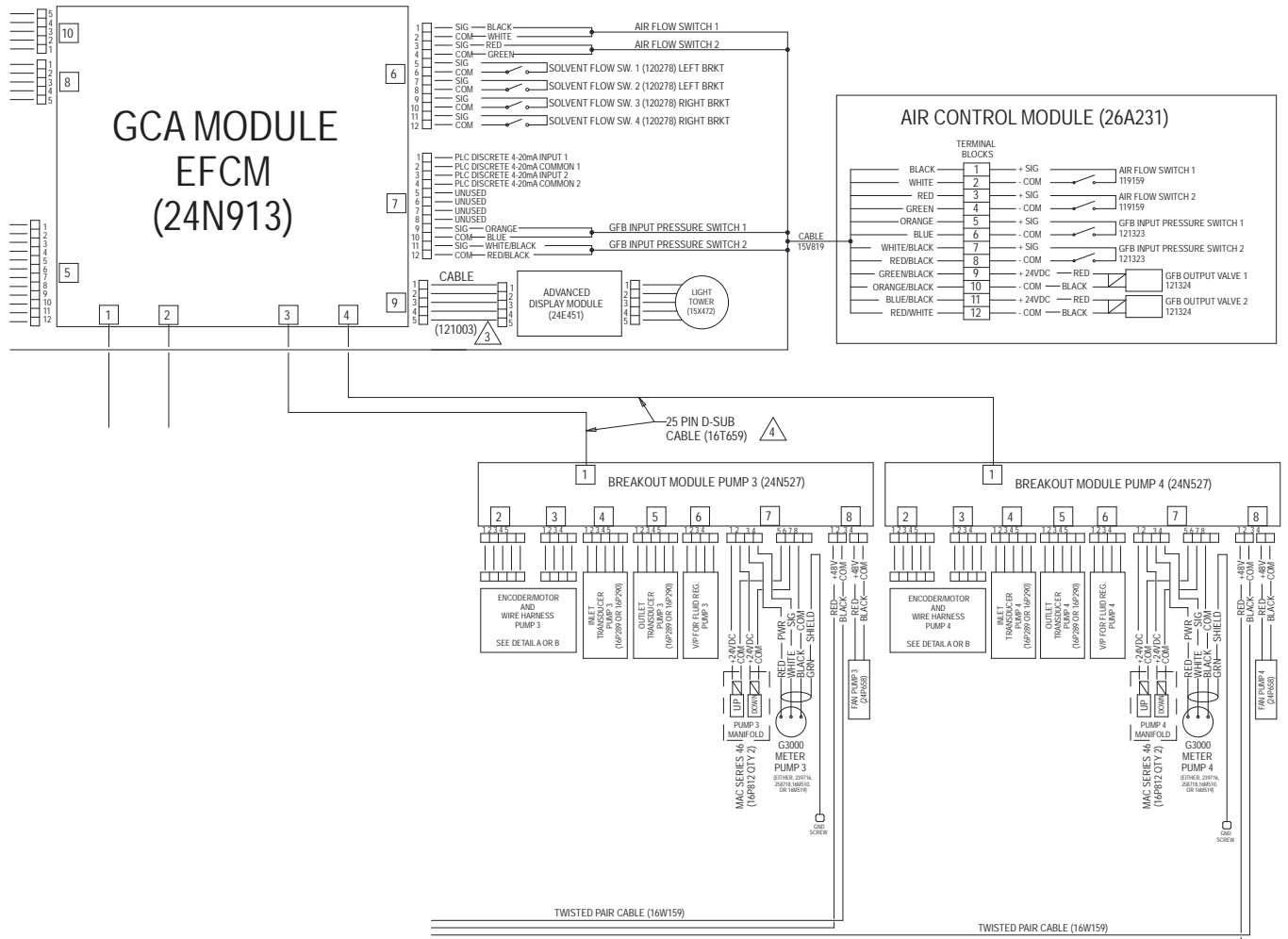

Figure 34 Electrical Schematic, Sheet 2, Part 2

CONTINUED ON THE NEXT PAGE

Electrical Schematics

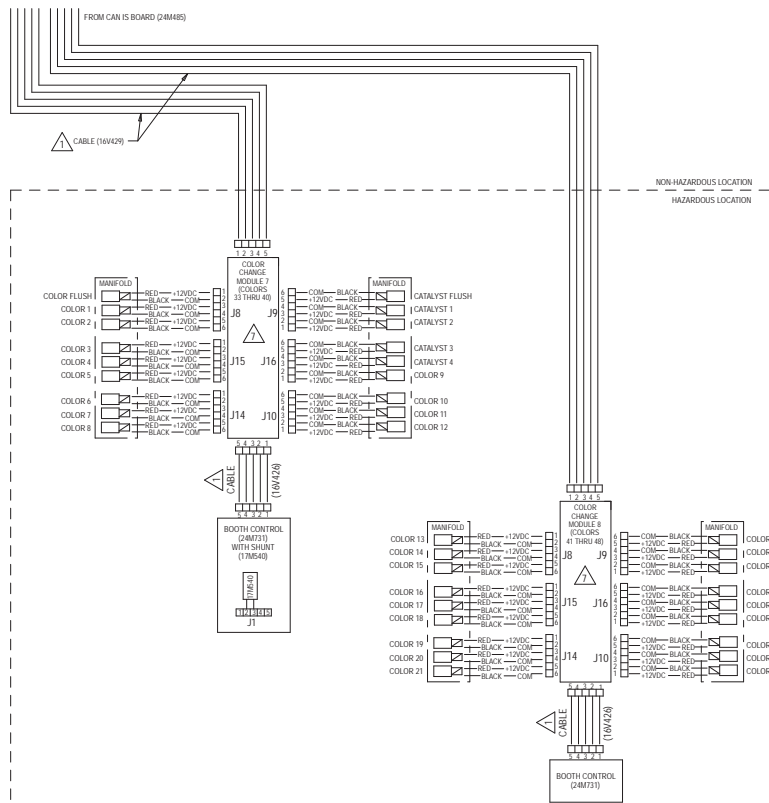
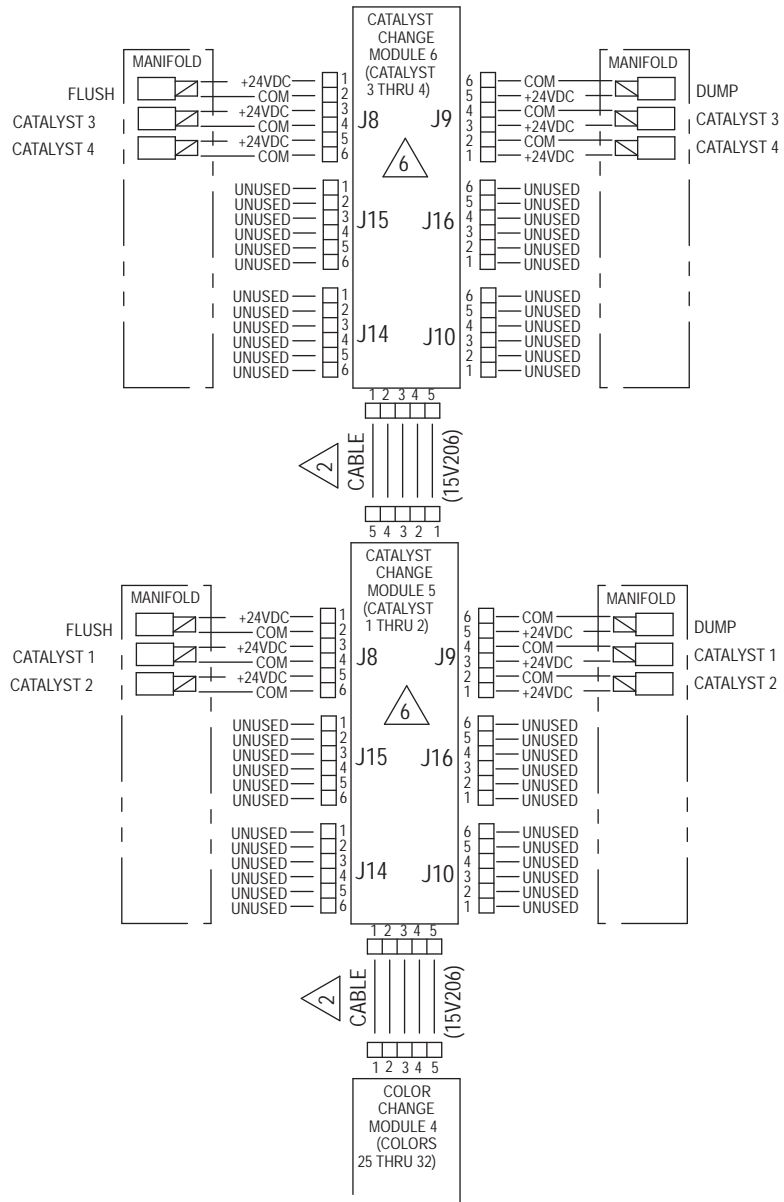

Figure 36 Electrical Schematic, Sheet 3, Part 2
 CONTINUED ON THE NEXT PAGE



ALTERNATE CONFIGURATION
FOR CATALYST CHANGE CONTROL
IN NON-HAZARDOUS LOCATION

Figure 37 Electrical Schematic, Sheet 4, Alternate Configuration for Catalyst Change Control

Pump Expansion Kit Parts

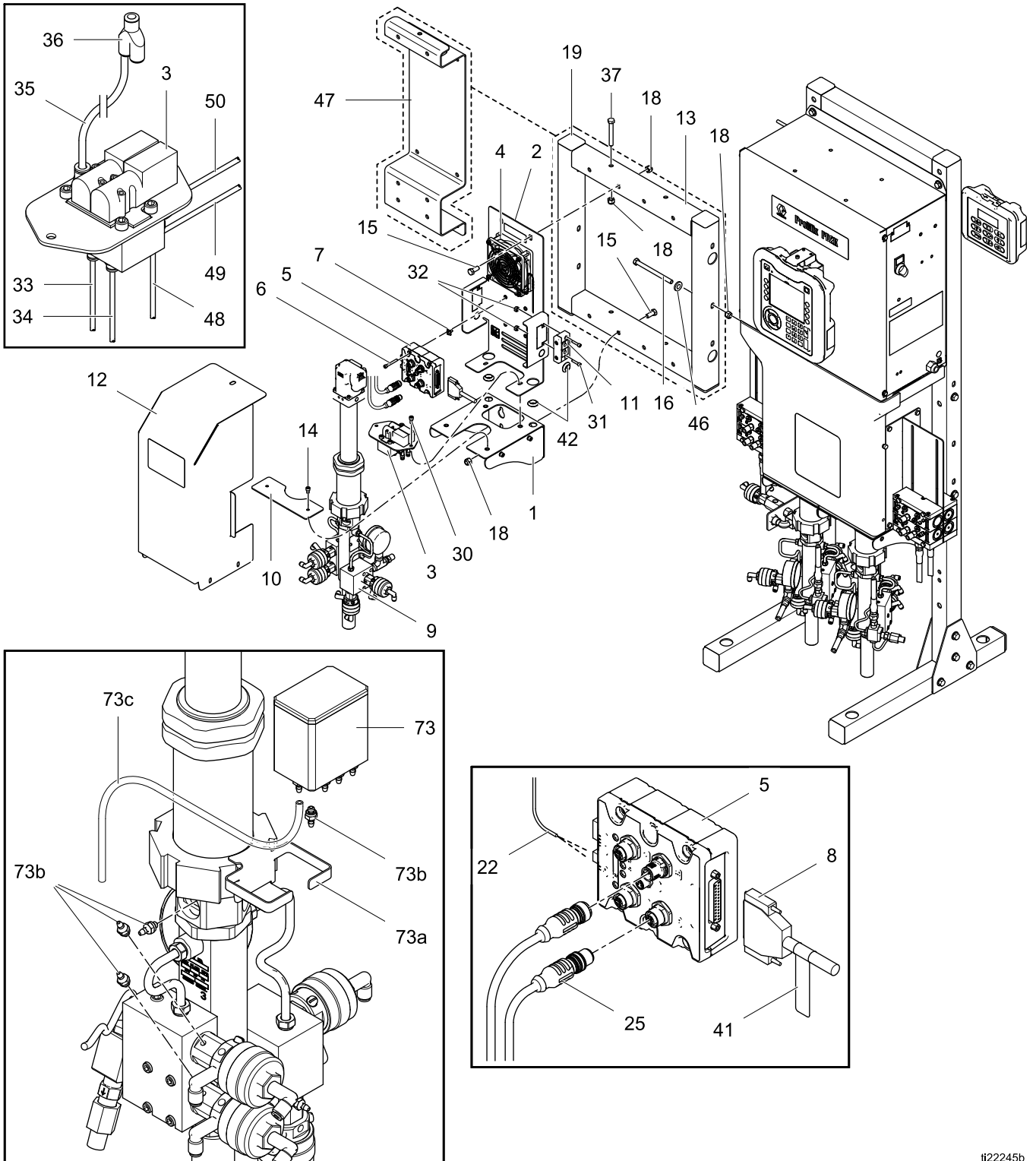

ti22245b

Part No. 24R968, 70 cc Low Pressure Color Pump Kit

Part No. 24R969, 70 cc High Pressure Color Pump Kit

Part No. 24R970, 35 cc Low Pressure Catalyst Pump Kit

Part No. 24R971, 35 cc High Pressure Catalyst Pump Kit

Part No. 25M268, 35 cc Low Pressure Acid Catalyst Pump Kit

Part No. 26A048, 35 cc High Pressure Acid Catalyst Pump Kit

Ref	Part	Description	Qty	Ref	Part	Description	Qty
1	— — —	BRACKET, mounting, pump	1	18	— — —	NUT, lock; 3/8–16	10
2	— — —	PANEL, back	1	19	— — —	PLUG, tube, square	4
3	24T772	MANIFOLD, solenoid	1	22	— — —	CABLE, 2–wire	1
4	24T770	KIT, fan	1	25	24P684	WIRE HARNESS; for Kits 24R968 and 24R970	1
5	24N527	MODULE, control, pump	1		24P685	WIRE HARNESS; for Kits 24R969, 24R971, and 26A048	1
6	— — —	SCREW, cap, socket head; 10–32 x 1.5 in. (38 mm)	4	27	— — —	TIE WRAP (not shown)	3
7	— — —	SCREW, ground; M5 x 0.8	1	30	101550	SCREW, cap, socket head; 1/4–20 x 1/2 in. (13 mm)	2
8	16V659	CABLE, D-SUB; 25 pin; 6 ft (1.83 m)	1	31	105209	SCREW, cap, socket head; 10–32 x 7/8 in. (22 mm)	4
9	24T790	PUMP, 70 cc, A side, low pressure; for Kit 24R968; see manual 332339	1	32	114231	NUT, lock; 10–32	4
	24T791	PUMP, 70 cc, A side, high pressure; for Kit 24R969; see manual 332339	1	33	— — —	TUBE, nylon, red; for control air to turn inlet and outlet valves off; 5/32 in. (4 mm) OD	6 ft (1.83 m)
	24T788	PUMP, 35 cc, B side, low pressure; for Kit 24R970; see manual 332339	1	34	— — —	TUBE, nylon, green; for control air to turn inlet up valve on; 5/32 in. (4 mm) OD	1.5 ft (457 mm)
	24T789	PUMP, 35 cc, B side, high pressure; for Kit 24R971; see manual 332339	1	35	— — —	TUBE, polyethylene; 1/4 in. (6 mm) OD x 6 ft (1.83 m)	6 ft (1.83 m)
	24T818	PUMP, 35 cc, B side, low pressure; for Kit 25M268; see manual 332339	1	36	115287	Y-FITTING; 1/4 in. (6 mm) OD tubing	1
	24T819	PUMP, 35 cc, B side, high pressure; for Kit 26A048; see manual 332339	1	37	— — —	SCREW, cap, hex head; 3/8–16 x 2.75 in. (70 mm)	1
10	— — —	BRACKET, mounting, pump	1	41	16X048	LABEL, notice	2
11	— — —	GROMMET, dual cable	2	42	— — —	GROMMET	3
12	16V858	COVER	1	46	— — —	WASHER; 3/8	3
13	— — —	FRAME	1	47	— — —	BRACKET, wall (use with PD1K)	1
14	C19798	SCREW, cap, socket head; 1/4–20 x 3/8 in. (10 mm)	6	48	— — —	TUBE, nylon, black; for control air to turn inlet down valve on; 5/32 in. (4 mm) OD	1.5 ft (457 mm)
15	— — —	SCREW, cap, hex head; 3/8–16 x 7/8 in. (22 mm)	7	49	— — —	TUBE, nylon, blue; for control air to turn outlet up valve on; 5/32 in. (4 mm) OD	1.5 ft (457 mm)
16	— — —	SCREW, cap, hex head; 3/8–16 x 3.75 in. (95 mm)	3	50	— — —	TUBE, nylon, yellow; for control air to turn outlet down valve on; 5/32 in. (4 mm) OD	1.5 ft (457 mm)

Pump Expansion Kit Parts

Ref	Part	Description	Qty	Ref	Part	Description	Qty
73	24T302	KIT, cup, TSL; includes items 73a-73e	1	73d	— — —	PLUG, screw; 10–32; to replace unused item 73b at TSL cup; not shown	4
73a	— — —	BRACKET	1	73e	— — —	GASKET; for item 73d; not shown	4
73b	24U617	KIT, barbed fittings; includes o-rings; package of 12	1				
73c	— — —	TUBE, polyurethane; 1/4 in. (6 mm) OD; 10 ft (3.05 m); cut to fit	1				

Items marked — — — are not available separately.

Technical Data

Pump Expansion Kit	U.S.	Metric
Maximum fluid working pressure:		
Kits 24R968, 24R970, and 25M268	300 psi	2.1 MPa, 21 bar
Kits 24R969, 24R971, and 26A048	1500 psi	10.5 MPa, 105 bar
Maximum working air pressure:	100 psi	0.7 MPa, 7.0 bar
Wetted parts:	See Pump manual 332339.	

Graco Standard Warranty

Graco warrants all equipment referenced in this document which is manufactured by Graco and bearing its name to be free from defects in material and workmanship on the date of sale to the original purchaser for use. With the exception of any special, extended, or limited warranty published by Graco, Graco will, for a period of twelve months from the date of sale, repair or replace any part of the equipment determined by Graco to be defective. This warranty applies only when the equipment is installed, operated and maintained in accordance with Graco's written recommendations.

This warranty does not cover, and Graco shall not be liable for general wear and tear, or any malfunction, damage or wear caused by faulty installation, misapplication, abrasion, corrosion, inadequate or improper maintenance, negligence, accident, tampering, or substitution of non-Graco component parts. Nor shall Graco be liable for malfunction, damage or wear caused by the incompatibility of Graco equipment with structures, accessories, equipment or materials not supplied by Graco, or the improper design, manufacture, installation, operation or maintenance of structures, accessories, equipment or materials not supplied by Graco.

This warranty is conditioned upon the prepaid return of the equipment claimed to be defective to an authorized Graco distributor for verification of the claimed defect. If the claimed defect is verified, Graco will repair or replace free of charge any defective parts. The equipment will be returned to the original purchaser transportation prepaid. If inspection of the equipment does not disclose any defect in material or workmanship, repairs will be made at a reasonable charge, which charges may include the costs of parts, labor, and transportation.

THIS WARRANTY IS EXCLUSIVE, AND IS IN LIEU OF ANY OTHER WARRANTIES, EXPRESS OR IMPLIED, INCLUDING BUT NOT LIMITED TO WARRANTY OF MERCHANTABILITY OR WARRANTY OF FITNESS FOR A PARTICULAR PURPOSE.

Graco's sole obligation and buyer's sole remedy for any breach of warranty shall be as set forth above. The buyer agrees that no other remedy (including, but not limited to, incidental or consequential damages for lost profits, lost sales, injury to person or property, or any other incidental or consequential loss) shall be available. Any action for breach of warranty must be brought within two (2) years of the date of sale.

GRACO MAKES NO WARRANTY, AND DISCLAIMS ALL IMPLIED WARRANTIES OF MERCHANTABILITY AND FITNESS FOR A PARTICULAR PURPOSE, IN CONNECTION WITH ACCESSORIES, EQUIPMENT, MATERIALS OR COMPONENTS SOLD BUT NOT MANUFACTURED BY GRACO. These items sold, but not manufactured by Graco (such as electric motors, switches, hose, etc.), are subject to the warranty, if any, of their manufacturer. Graco will provide purchaser with reasonable assistance in making any claim for breach of these warranties.

In no event will Graco be liable for indirect, incidental, special or consequential damages resulting from Graco supplying equipment hereunder, or the furnishing, performance, or use of any products or other goods sold hereto, whether due to a breach of contract, breach of warranty, the negligence of Graco, or otherwise.

FOR GRACO CANADA CUSTOMERS

The Parties acknowledge that they have required that the present document, as well as all documents, notices and legal proceedings entered into, given or instituted pursuant hereto or relating directly or indirectly hereto, be drawn up in English. Les parties reconnaissent avoir convenu que la rédaction du présente document sera en Anglais, ainsi que tous documents, avis et procédures judiciaires exécutés, donnés ou intentés, à la suite de ou en rapport, directement ou indirectement, avec les procédures concernées.

Graco Information

For the latest information about Graco products, visit www.graco.com.

To place an order, contact your Graco Distributor or call to identify the nearest distributor.

Phone: 612-623-6921 **or Toll Free:** 1-800-328-0211 **Fax:** 612-378-3505

All written and visual data contained in this document reflects the latest product information available at the time of publication.

Graco reserves the right to make changes at any time without notice.

For patent information, see www.graco.com/patents.

Original Instructions. This manual contains English. MM 332456

Graco Headquarters: Minneapolis

International Offices: Belgium, China, Japan, Korea

GRACO INC. AND SUBSIDIARIES • P.O. BOX 1441 • MINNEAPOLIS MN 55440-1441 • USA

Copyright 2013, Graco Inc. All Graco manufacturing locations are registered to ISO 9001.

www.graco.com
Revision C, February 2017