

Instructions - Installation

Stainless Steel or Carbon Steel



Air-Powered Glutton® Pumps

307843ZAL

EN

Piston pump for waterborne and solvent-based paints and catalysts. For professional use only.



Important Safety Instructions

Read all warnings and instructions in this manual before using this equipment. Save these instructions.

See page 3 for model information, including maximum working pressure and approvals.

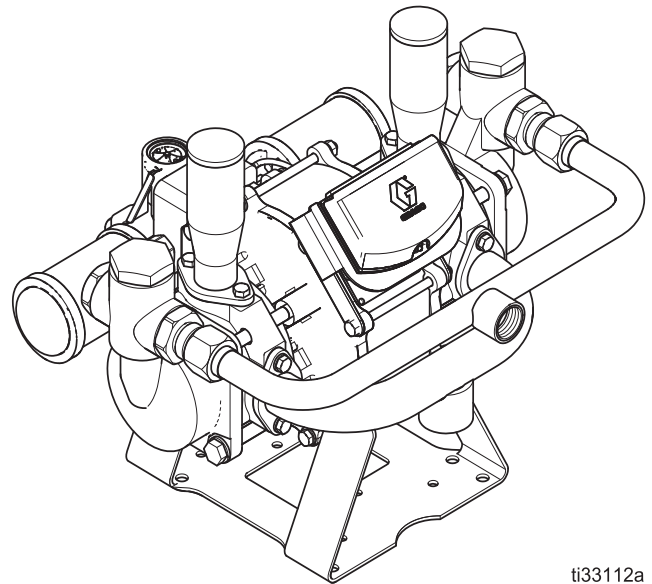

ti33112a

Contents

Related Manuals	2	Repair/Service	16
Models	3	Repairing the Ball Check Valves	16
Warnings	4	Repairing the Fluid Piston and Seal	16
Installation	6	Repairing the Air Motor and Piston	18
General Information	6	Repair or Replace the Air Valve	19
Mounting the Pump	6	DataTrak	22
Typical Installation	7	Parts	23
Grounding	8	Air Valve Parts	26
Fluid Outlet Line	9	Repair and Conversion Kits	28
Connect the Fluid Suction Line	10	Accessories	28
Air Line	10	Performance Charts	29
Operation	11	400 Series Pumps	29
Pressure Relief Procedure	11	1200 Series Pumps	30
Flush the Pump Before First Use	11	2500 Series Pumps	31
Start and Adjust the Pump	11	Dimensions and Mounting Hole Layout	32
Pump Shutdown	12	Notes	33
Maintenance	13	Technical Specifications	34
Lubrication	13	Graco Standard Warranty	36
Flush the Pump With Compatible Solvent	13	Graco Information	36
Tighten Threaded Connections	13		
Preventive Maintenance Schedule	13		
Troubleshooting	14		

Related Manuals

Manual Number	Title
313840	DataTrak™ Kit Instructions
3A5753	Reed Switch (Cycle Count) Kit 17W772
3A5801	Air Valve Conversion Kits 17W667 and 17W668 for Glutton Pumps

Models

See **Notes** on page 33 for a complete materials list. See **Performance Charts** on page 29 for actual working pressures and flow rates.

The maximum air input pressure for all models is 100 psi (0.7 MPa, 7 bar).

Pump Series	Part No.	Series‡	Ratio	Maximum Fluid Working Pressure	Pump Housing Material	Piston Seal Material	Air Valve
400	220663	E	4:1	400 psi (2.8 MPa, 28 bar)	Carbon steel	UHMWPE	Standard
	237008	E	4:1		Carbon steel	Nylon	Standard
	220666	E	4:1		Stainless steel	UHMWPE	Standard
	237011	E	4:1		Stainless steel	Nylon	Standard
	17W012	E	4:1		Stainless steel	UHMWPE	Advanced*
1200	220664	E	12:1	1200 psi (8 MPa, 83 bar)	Carbon steel	UHMWPE	Standard
	237009	E	12:1		Carbon steel	Nylon	Standard
	220667	E	12:1		Stainless steel	UHMWPE	Standard
	237012	E	12:1		Stainless steel	Nylon	Standard
	17W013	E	12:1		Stainless steel	UHMWPE	Advanced*
2500	220668	E	25:1	2500 psi (17 MPa, 170 bar)	Stainless steel	UHMWPE	Standard
	237013	E	25:1		Stainless steel	Nylon	Standard
	17W014	E	25:1		Stainless steel	UHMWPE	Advanced*

* Advanced models include DataTrak monitoring and runaway protection.

‡ To upgrade pumps from a previous series to a series E air valve, see manual 3A5801, Air Valve Conversion Kits 17W667 and 17W668 for Glutton Pumps.

Standard pump models are certified:



Advanced pump models are certified:

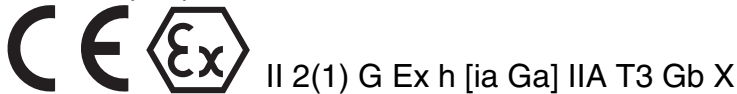

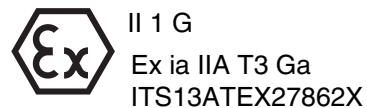
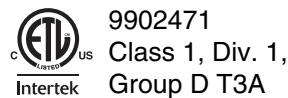

* DataTrak is certified:









Warnings

The following warnings are for the setup, use, grounding, maintenance, and repair of this equipment. The exclamation point symbol alerts you to a general warning and the hazard symbols refer to procedure-specific risks. When these symbols appear in the body of this manual or on warning labels, refer back to these warnings. Product-specific hazard symbols and warnings not covered in this section may appear throughout the body of this manual where applicable.

 <h1 style="margin: 0;">WARNING</h1>	
	<p>FIRE AND EXPLOSION HAZARD</p> <p>Flammable fumes, such as solvent and paint fumes, in the work area can ignite or explode. Paint or solvent flowing through the equipment can cause static sparking. To help prevent fire and explosion:</p> <ul style="list-style-type: none"> • Use equipment only in a well-ventilated area. • Eliminate all ignition sources; such as pilot lights, cigarettes, portable electric lamps, and plastic drop cloths (potential static sparking). • Ground all equipment in the work area. See Grounding instructions. • Never spray or flush solvent at high pressure. • Keep work area free of debris, including solvent, rags and gasoline. • Do not plug or unplug power cords, or turn power or light switches on or off when flammable fumes are present. • Use only grounded hoses. • Hold the gun firmly to the side of a grounded pail when triggering into a pail. Do not use pail liners unless they are antistatic or conductive. • Stop operation immediately if static sparking occurs or you feel a shock. Do not use equipment until you identify and correct the problem. • Keep a working fire extinguisher in the work area.
	<p>SKIN INJECTION HAZARD</p> <p>High-pressure fluid from dispensing device, hose leaks, or ruptured components will pierce skin. This may look like just a cut, but it is a serious injury that can result in amputation. Get immediate surgical treatment.</p> <ul style="list-style-type: none"> • Engage trigger lock when not dispensing. • Do not point dispensing device at anyone or at any part of the body. • Do not put your hand over the fluid outlet. • Do not stop or deflect leaks with your hand, body, glove, or rag. • Follow the Pressure Relief Procedure when you stop dispensing and before cleaning, checking, or servicing equipment. • Tighten all fluid connections before operating the equipment. • Check hoses and couplings daily. Replace worn or damaged parts immediately.

! WARNING

 	<p>EQUIPMENT MISUSE HAZARD</p> <p>Misuse can cause death or serious injury.</p> <ul style="list-style-type: none"> • Do not operate the unit when fatigued or under the influence of drugs or alcohol. • Do not exceed the maximum working pressure or temperature rating of the lowest rated system component. See Technical Specifications in all equipment manuals. • Use fluids and solvents that are compatible with equipment wetted parts. See Technical Specifications in all equipment manuals. Read fluid and solvent manufacturer's warnings. For complete information about your material, request Safety Data Sheets (SDSs) from your distributor or retailer. • Do not leave the work area while equipment is energized or under pressure. • Turn off all equipment and follow the Pressure Relief Procedure when equipment is not in use. • Check equipment daily. Repair or replace worn or damaged parts immediately with genuine manufacturer's replacement parts only. • Do not alter or modify equipment. Alterations or modifications may void agency approvals and create safety hazards. • Make sure all equipment is rated and approved for the environment in which you are using it. • Use equipment only for its intended purpose. Call your distributor for information. • Route hoses and cables away from traffic areas, sharp edges, moving parts, and hot surfaces. • Do not kink or over bend hoses or use hoses to pull equipment. • Keep children and animals away from the work area. • Comply with all applicable safety regulations. • Do not lift pressurized equipment.
 	<p>MOVING PARTS HAZARD</p> <p>Moving parts can pinch, cut or amputate fingers and other body parts.</p> <ul style="list-style-type: none"> • Keep clear of moving parts. • Do not operate equipment with protective guards or covers removed. • Pressurized equipment can start without warning. Before checking, moving, or servicing equipment, follow the Pressure Relief Procedure and disconnect all power sources.
	<p>TOXIC FLUID OR FUMES HAZARD</p> <p>Toxic fluids or fumes can cause serious injury or death if splashed in the eyes or on skin, inhaled, or swallowed.</p> <ul style="list-style-type: none"> • Read Safety Data Sheets (SDSs) to know the specific hazards of the fluids you are using. • Store hazardous fluid in approved containers, and dispose of it according to applicable guidelines.
	<p>BURN HAZARD</p> <p>Equipment surfaces and fluid that is heated can become very hot during operation. To avoid severe burns:</p> <ul style="list-style-type: none"> • Do not touch hot fluid or equipment.
	<p>PERSONAL PROTECTIVE EQUIPMENT</p> <p>Wear appropriate protective equipment when in the work area to help prevent serious injury, including eye injury, hearing loss, inhalation of toxic fumes, and burns. Protective equipment includes but is not limited to:</p> <ul style="list-style-type: none"> • Protective eyewear, and hearing protection. • Respirators, protective clothing, and gloves as recommended by the fluid and solvent manufacturer.

Installation

General Information

- The **Typical Installation** on page 7 is only a guide for installing system components and accessories. It is not an actual system design. Contact your Graco distributor for assistance in designing a system to suit your particular needs.
- Always use genuine Graco parts and accessories, available from your Graco distributor. If you supply your own accessories, be sure they are adequately sized and pressure-rated for your system.
- Reference numbers and letters in parentheses refer to the reference numbers in the typical installation figures and the parts lists.
- Use a thread sealant compatible with the fluid being pumped on all male pipe threads. Tighten all connections firmly to avoid air or fluid leaks.

Mounting the Pump

- **400 and 1200 Series Pumps:** Mount the pump with the accumulators in the top position. The accumulators must be in the position shown or the pump will not prime. See Mounting Hole Layout, page 33.
- Be sure the pump is securely bolted to its mounting and that the mounting can support the weight of the pump, hoses, and stress caused during operation.

NOTE: Use parts 255143 (wall mount bracket) and 17W670 (adapter kit).

- The outlet manifold can be removed and turned 180 degrees to change the direction of the outlet and ease installation.
- For ease of operation and service, mount the pump so the air inlet, fluid inlet, and fluid outlet ports are easily accessible.
 - The pump fluid outlet on the 400 and 1200 Series Pumps is 1 npt(f).
 - The pump fluid outlet on the 2500 Series Pump is 3/4 npt(f).
 - The pump fluid inlet is 1.25 npt(f).

- Mount the pump in a well-ventilated area with sufficient clearance on all sides for operator access and servicing.

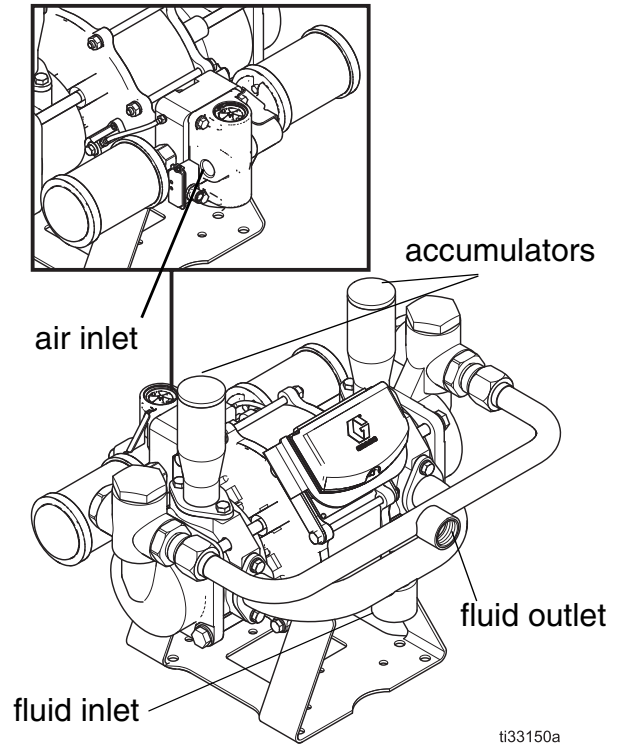

ti33150a

Typical Installation

The pump is sold separately from all accessories. Filters, regulators, fittings, hoses, and so on, are shown here to depict one possible system setup.

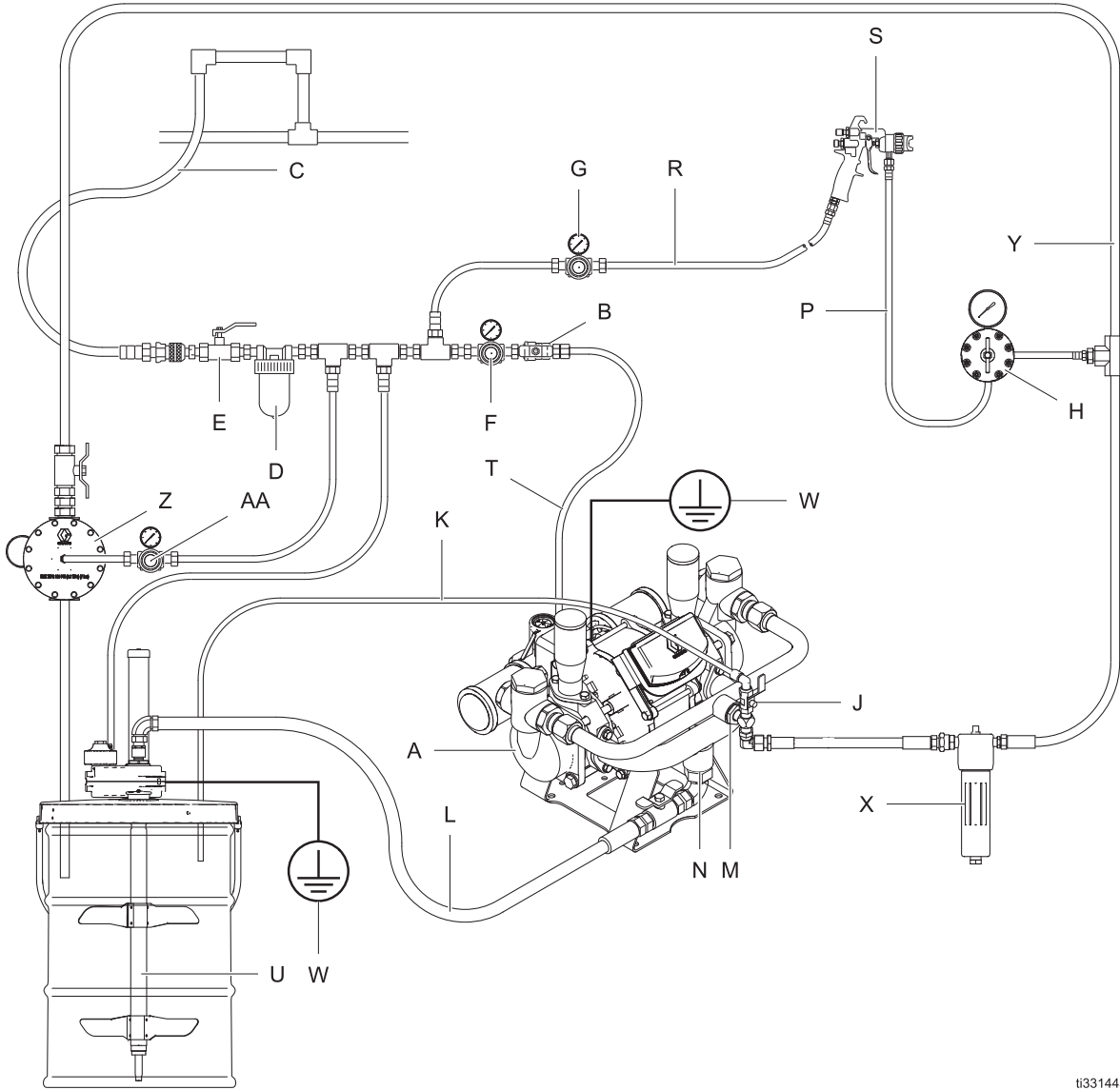



i33144a

Key

A	Pump
B	Bleed-type master air valve (required)
C	Air supply line
D	Air line filter
E	Air line shutoff valve
F	Pump air regulator
G	Air gun regulator
H	Fluid pressure regulator
J	Fluid drain valve
K	Drain tube
L	Fluid suction line

M	Pump fluid outlet
N	Pump fluid inlet
P	Fluid hose
R	Gun air hose
S	Spray gun
T	Pump air inlet
U	Agitator
W	Ground wire
X	Fluid filter
Y	Fluid circulation line
Z	Back pressure regulator (BPR)
AA	BPR air regulator

Grounding

				
<p>The equipment must be grounded to reduce the risk of static sparking. Static sparking can cause fumes to ignite or explode. Grounding provides an escape wire for the electric current.</p>				

Ground all of the following equipment:

- **Pump:** Use a ground wire and clamp. Loosen the grounding screw. Insert one end of a 12 ga (1.5 mm²) minimum ground wire (W) under the clamp and tighten the screw securely. Connect the other end of the wire to a true earth ground. For a ground wire and clamp, order Part No. 222011.
- **Air and fluid hoses:** Use only electrically conductive hoses.
- **Air compressor:** Follow the manufacturer's recommendations.
- **Fluid supply container:** Follow local codes.
- **Fluid pails used when flushing:** Follow local codes. Use only conductive metal pails placed on a grounded surface. Do not place the pail on a non-conductive surface, such as paper or cardboard, which interrupts grounding continuity.

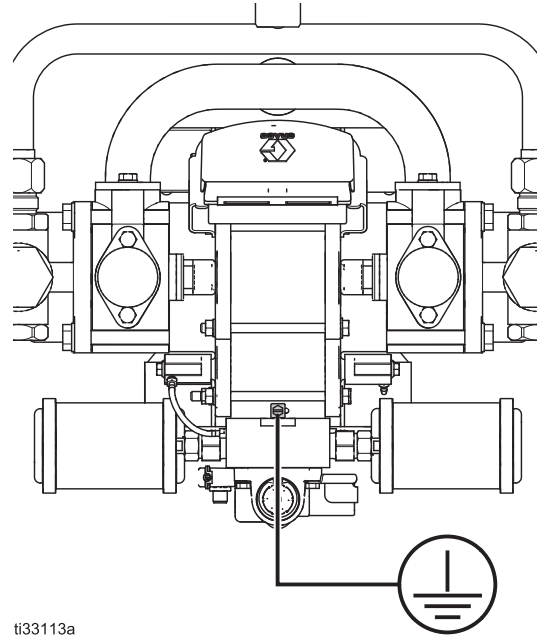

ti33113a

Fluid Outlet Line

1. Use electrically conductive fluid hoses (P). Attach the fluid fitting onto the pump fluid outlet (M) snugly while supporting the outlet with a wrench. See **Notes** to determine the fluid outlet size of your pump.
2. Install a fluid pressure regulator (H) at the pump fluid outlet to control fluid pressure, if desired.

Note: The fluid pressure can be controlled with either an air regulator to control the air into the pump, or with a fluid regulator to control the fluid out of the pump. See **Air Line** for installation instructions.

3. Install a fluid drain valve (J) near the fluid outlet. To use the valve as a circulation valve, connect a drain tube (K) between the valve and pail.

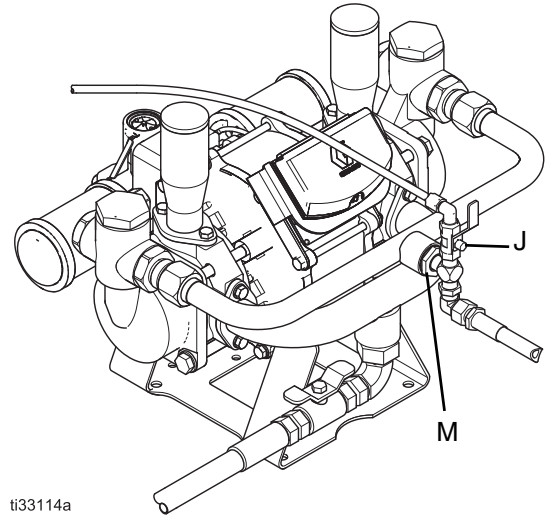

ti33114a

<p>A fluid drain valve (J) is required in your system to relieve pressure in the hose if it is plugged. The drain valve reduces the risk of serious injury, including skin injection or splashing in the eyes or on the skin.</p>				

<p>Thermal expansion of fluid in the outlet line can cause overpressurization. Thermal expansion can occur when using long fluid lines exposed to sunlight or ambient heat, or when pumping from a cool to a warm area (for example, from an underground tank).</p> <p>Overpressurization can cause the pump or hose to rupture and cause serious injury, including skin injection or splashing in the eyes or on the skin. To prevent overpressurization, install a pressure relief valve (not supplied) at the pump outlet.</p>				

Connect the Fluid Suction Line

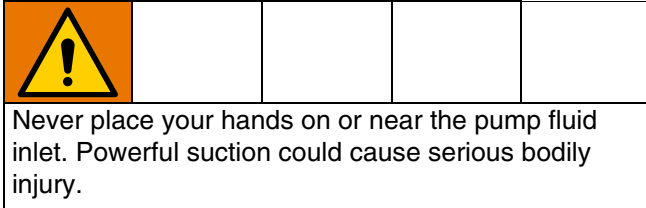

NOTICE
The pump must be suction-fed to operate properly. Pressure feeding or exceeding 15 psi (104 kPa, 1.04 bar) maximum fluid inlet pressure may cause premature bellows seal failure.

Connect the fluid suction line (L) to the pump fluid inlet (M).

- The maximum suction lift is 15 ft (4.57m) for the 400 Series and 1200 Series Pumps, and 6 ft (1.83 m) for the 2500 Series Pump.
- Use flexible, conductive hoses.
- Use a material compatible liquid thread sealant on connections to prevent air from entering the fluid line.
- Attach the suction line into the pump fluid inlet (N) snugly.

Air Line

1. Install the air line accessories as shown in the **Typical Installation** on page 7. Use adaptors as needed. Be sure the air line supplying the accessories is grounded.

NOTE: The fluid pressure can be controlled with either an air regulator (F) to control the air into the pump, or with a fluid pressure regulator (H) to control the fluid out of the pump.

- a. Install a bleed-type master air valve (B) close to the pump. This valve is required in your system to relieve air trapped between it and the pump when the valve is closed. Be sure the bleed valve is easily accessible from the pump, and is located downstream from the air regulator.

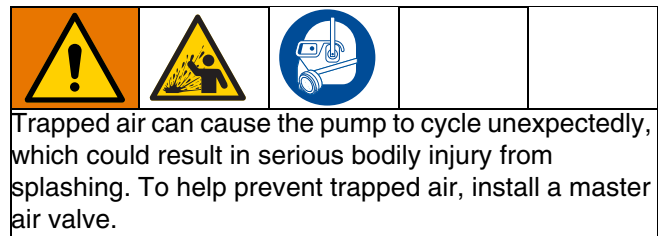

- b. Install an air line shutoff valve (E) upstream from all air line accessories to isolate them during cleaning and repair.
- c. Install an air line filter (D) to remove contaminants such as dirt, moisture, and oil from the compressed air supply.

NOTE: The air valve on the pump does not require lubrication.

2. Install a grounded flexible air hose between the accessories and the 1/2 in. npt(f) air gun regulator inlet (G). See **Notes** to determine the air inlet size of your pump. Use a minimum 1/2 in. (13 mm) ID air hose.
3. Optionally, install an accessory Pressure Limit Kit in the air line, close to the air inlet. See **Air Valve Parts** for the correct kit for your pump size.

Operation

Pressure Relief Procedure



Follow the Pressure Relief Procedure whenever you see this symbol.



This equipment stays pressurized until pressure is manually relieved. To help prevent serious injury, including skin injection or splashing in the eyes or on the skin, follow the **Pressure Relief Procedure** when you stop pumping and before you clean, check, or service the equipment.

1. Shut off the air supply to the pump.
2. Hold a metal part of the gun (if used) to a grounded metal pail. Trigger the gun to relieve the pressure.
3. Open all fluid valves in the system, having a waste container ready to catch the drainage. Leave the drain valves open until you are ready to return to operation.

Flush the Pump Before First Use

The pump was tested with lightweight oil, which is left in to protect the pump parts. If this solution could contaminate the fluid you are pumping, flush it thoroughly with a compatible solvent.

Start and Adjust the Pump

1. Be sure the pump is properly grounded.
2. Check all fittings to be sure they are tight. Be sure to use a thread sealant compatible with the fluid being pumped on all male threads
3. Place the suction line (L) in the fluid to be pumped.
4. Place the end of the fluid hose (P) into an appropriate container (if flushing) or connect to a gun or other dispensing device.
5. Close the fluid drain valve (J).
6. With the pump air regulator (F) closed, open the bleed-type master air valve (B).

7. If the fluid hose has a dispensing device, hold it open while continuing with the following steps.
8. Slowly open the pump air regulator (F). Adjust it until the pump runs smoothly.
9. Allow the pump to cycle slowly until all air is pushed out of the lines (the fluid will be flowing in a steady stream from the fluid outlet) and the pump is primed.



To reduce the risk of component rupture, which could cause serious bodily injury, never exceed 100 psi (0.7 MPa, 7 bar) air supply pressure to the pump.

10. If you are flushing:
 - a. Run the pump long enough to thoroughly clean the pump and hoses.
 - b. Close the fluid control device and pump air regulator (F).
 - c. Remove the fluid suction line (L) from the solvent and place it in the fluid to be pumped.
11. If you are going to use the pump:
 - a. Start the pump. Be sure the suction line is in the supply container.
 - b. If you are using this pump to spray fluid, follow the **Pressure Relief Procedure** on page 11, then install a spray tip in the gun. Trigger the gun into a grounded metal waste container to prime the hose. Adjust the pump pressure just enough to completely atomize the fluid. Higher pressures cause premature spray tip and pump wear.

NOTE: In a direct supply system, the pump starts and stops as the spray gun, dispensing valve, or fluid outlet valve is opened and closed. In a circulating system, the pump runs continuously and speeds up or slows down as supply demands until the air supply is shut off.

Pump Shutdown



For a short-term shutdown, relieve the pressure. Follow the **Pressure Relief Procedure** on page 11.

For a long-term shutdown, such as several hours or overnight, do the following:

1. Flush the pump thoroughly, especially if pumping a material that will set up.
2. Leave compatible flushing fluid in the pump.
3. Remove the suction hose from the fluid container and run the pump until the fluid is forced out of the system, then shut off the air supply immediately.
4. Relieve the pressure. Follow the **Pressure Relief Procedure** on page 11.
5. For more information, see the **Maintenance** instructions on page 13.







Maintenance

Lubrication

The pump is lubricated at the factory. It is designed to require no further lubrication for the life of the pump.

NOTICE
Do not over-lubricate the pump. Oil is exhausted through the muffler and could contaminate your fluid supply or other equipment. Excessive lubrication can also cause the pump to malfunction.

Flush the Pump With Compatible Solvent

Improper handling of hazardous fluids or inhaling their vapors can cause serious bodily injury.

All systems using hazardous fluid in enclosed areas or within buildings should have a properly designed and installed ventilation system. Consult your local building code and other industrial and governmental standards for proper design criteria.

To avoid fire and explosion, always ground equipment and waste container. To avoid injury from splashing and static buildup, always flush at the lowest possible pressure.

- Flush the pump often enough to prevent the fluid you are pumping from curing, drying, or freezing in the pump and damaging it.
- Flush with a fluid that is compatible with the fluid you are pumping and with the equipment wetted parts.
- Always flush before storing.
 - If you are pumping water-based fluid, first flush the pump with water, then with mineral spirits or a compatible oil-based solvent.

- Leave the mineral spirits or oil-based solvent in the pump to protect the pump parts from corrosion.
- Eliminate all air from the system.
- Follow the **Pressure Relief Procedure** on page 11 before storing the pump.
- Flush procedures vary widely by system requirements. See **Start and Adjust the Pump** for one common method of flushing. If your system is different, or if you are unsure how to completely flush your system, contact your Graco distributor.

Tighten Threaded Connections

- Before each use, check all hoses for wear or damage and replace as necessary.
- Be sure all threaded connections are tight, and leak-free.
- At least every six months, check and tighten all threaded connections, including manifold screws, clamps, plugs, and valve screws.

Preventive Maintenance Schedule

Establish a preventive maintenance schedule based on the service history of the pump. Scheduled maintenance is especially important to prevent spills or leakage due to pump failure.

Troubleshooting



Before disassembling the pump, check all probable causes and relieve the pressure. Follow the **Pressure Relief Procedure** on page 11.

Problem	Cause	Solution
The pump cycles at stall or fails to hold pressure at stall.	The outlet fluid valve is worn.	Replace the outlet fluid valve.
The pump will not cycle, or it cycles once and stops.	The air valve is stuck or dirty.	Disassemble and clean the air valve. Use filtered air.
	The fluid dispensing valve is clogged.	Relieve the pressure and clear the valve.
	The fluid hose line is pinched.	Check the lines.
	Pilot valves are not working.	Replace the pilot valves.
The pump operates erratically.	Suction line is loose.	Tighten the suction line.
Pump is running irregularly. The stroke frequency is dropping, coming to a standstill.	The pump is icing. Possible causes include: compressed air is too moist; the stroke frequency is too high; and the local temperature is too low.	Remove the ice by changing the operating conditions.
Air escapes continually from the muffler.	The air valve cup is damaged.	Replace the damaged parts.
	Foreign matter is inside the pump.	Check the air filter.
The pump does not start, or pressure fluctuates.	The inlet strainer is blocked. Maximum suction is exceeded. The hose or seal is defective.	Clean the strainer. Replace defective parts.
	The fluid is contaminated. The pump was installed or operated incorrectly.	Check the fluid supply. Follow installation and operation instructions in this manual.
The pump will not prime.	Air is getting into the intake housing due to a defective o-ring (19) on the intake manifold or accumulator.	Replace the o-ring.
	Air is getting into the intake housing because the suction hose or tube is not sealed.	Tighten or add sealant to the threads.

Problem	Cause	Solution
The pump will not run.	The air supply is turned off.	Turn the air supply on.
	The fluid valve is turned off.	Turn the fluid supply valve on.
	The air pressure regulator is set too low.	Increase the air pressure regulator adjustment. The minimum air pressure on the regulator is 15 psi (103 kPa, 1.03 bar), depending on the fluid being pumped.
	The pilot valve assemblies are worn.	Replace the pilot valves.
	The air control valve is defective.	Check for air coming from the exhaust when the pump is not running. Repair or replace the air control valve.
	The air piston quad ring (28) is worn.	Replace the quad ring.
The pump runs but does not maintain constant pressure.	Air is in the fluid line.	Check for spitting at the fluid line outlet. Bleed the fluid line until constant flow is obtained.
	The air line is too small.	Install a larger air line, with a minimum size of 1/2 in.
	The ball (57) and seat (49) are obstructed or worn.	When the pump fast cycles on one end of the stroke, it indicates that side is bypassing. Remove, clean, and inspect the seat, ball, and ball guide (56). Replace items if they are worn.
	The fluid piston (17), piston seal (13), or both are worn.	When the pump fast cycles on one end of the stroke, it indicates that side is bypassing. Replace the piston, seal, or both.
	The air control valve mufflers (38) are plugged.	Check for slow air flow at muffler. Remove and replace mufflers.
	The air control valve is dirty or worn.	Repair or replace air control valve.
	The air passages are dirty.	Check for sluggish air control valve operation. Clean the air passages; do not enlarge the orifices. Empty the air line filter and the control valve filter (40q).
Paint is dripping externally around the piston rod.	The bellows seal (14) has ruptured.	Check for presence of paint around the piston shaft (15). Replace the bellows seal. Be sure to suction feed the pump and not pressure feed the pump. The maximum fluid inlet pressure is 15 psi (104 kPa, 1.04 bar).

Repair/Service

Repairing the Ball Check Valves

NOTE: Parts marked with an asterisk are included in a repair kit, for example, (54*). See page 28 for repair kit part numbers. Use all the parts in the kit for the best results.

Disassembly



1. Relieve the pressure. Follow the **Pressure Relief Procedure** on page 11.
2. Disconnect the air and fluid lines, remove the pump from its mounting, and place it on a bench.
3. Remove the cap (53) from each side of the outlet housing (33).
4. Remove the ball guide (56), ball (57), valve seat (49), and o-ring (48*) on each side of the outlet housing.
5. Inspect the ball stop (55) inside the cap (53) for wear. Remove the o-ring (54*). Replace if necessary.
6. Clean all parts and inspect for wear or damage. Replace as needed.

Assembly

1. Lubricate the o-rings (48*) and place one in the groove on each valve seat (49).
2. Into each outlet housing, install the valve seat (49) with the o-ring (48*) facing down. Install the ball (57), and ball guide (56) into each outlet housing (33).

NOTE: Stainless steel seats are reversible.

3. Lubricate the o-rings (54*) and the cap (53) threads. Place one o-ring on each cap. Screw the caps into the housing and torque them to 55 to 85 ft-lb (75 to 115 N•m).

NOTE: On stainless steel pumps, apply anti-seize lubricant to the threads of the cap (53).

Repairing the Fluid Piston and Seal

NOTE: Parts marked with an asterisk are included in a repair kit, for example, (52*). See page 28 for repair kit part numbers. Use all the parts in the kit for the best results.

Disassembly



1. Relieve the pressure. Follow the **Pressure Relief Procedure** on page 11.
2. Loosen the tube nuts (1) and remove the outlet manifold (50). Unscrew the connectors (51). Remove the o-ring (52*).
3. Remove the screws (34), washers (35), outlet housing (33), piston seal (13*), and retaining plate (12). Remove the o-ring (18*). Repeat on the other side of the pump.
4. Holding the screw (16) on one side of the pump, loosen the screw three or four turns on the opposite side of the pump, using a socket and breaker bar.
5. Remove the piston (17) by grasping it with your hand. Hit the screw (16) with a plastic mallet to drive the piston loose from the shaft. Remove the screw (16) and piston (17).
6. Remove the screws (32), washers (3), and intake manifold (47). Remove the o-rings (19*).
7. Remove the intake housing (36), bellows (14*), and retaining plate (20).
8. Holding the piston shaft (15) flat with a wrench, remove the remaining screw (16).
9. Repeat steps 6 and 7 on the opposite end of the pump. Clean all parts and inspect for wear or damage. Replace as needed.

Assembly

- Slide the retaining plate (20), bellows (14*), and intake housing (36) onto the piston shaft (15). Do not force the bellows. Repeat on the other side.)

NOTICE

To avoid damaging the bellows (14*), do not force it onto the shaft. The bellows will press into place when the piston (17) is secured.

- Install the piston (17) on the shaft (15) and secure it with the screw (16). Repeat on the opposite end of the pump.
- Using a socket and breaker bar, torque one screw (16) to 40 to 50 ft-lb (54 to 67 N•m), then repeat with the other screw.
- Grease and install an o-ring (19*) in each inlet. Install the intake manifold (47) with screws (32) and washers (3). Do not torque the screws yet.

NOTE: To avoid loosening the piston stud (30) during disassembly, do not overtighten the screws (16).

- If you are using a flat nylon seal, skip to the next step.

If you are using a formed UHMWPE seal, grease and install the o-ring (18*) in the groove in the tapered side of the retaining plate (12). Grease the outlet housing (33) and install the piston seal (13*) and retaining plate (12). Be sure the flat side of the retaining plate faces the piston seal. Secure with the four screws (34) and washers (35).

- Apply 10 psi air to move the piston to one side and hold it there. Replace the o-ring (18*) in the groove in the tapered side of the retaining plate (12).

Grease the outlet housing groove and set the seal (13) inside the groove. Carefully tip the housing (33) onto the inlet housing. Be sure the flat side of the retaining plate (12) faces the piston seal. Secure with the four screws (34) and washers (35).

Increase the air pressure to about 50 psi until the pump cycles and the piston drives to the other side. Reduce the air pressure to 10 psi to hold in position. Repeat the seal installation pattern. Increase the air pressure to 50 psi again to cause the pump to cycle again and form the seal on the first side.

NOTE: On 400 and 1200 Series pumps, torque the screws to 40 to 50 ft-lb (54 to 68 N•m). On the 2500 Series pump, torque the screws to 35 to 40 ft-lb (47 to 54 N•m).

- Torque the inlet manifold screws (32) to 7.4 to 12.5 ft-lb (10 to 17 N•m).
- Replace the o-ring (52*) in each outlet manifold connector (51) and lubricate the threads. Install the outlet manifold (50), torquing the connectors to 55 to 85 ft-lb (75 to 115 N•m).

NOTE: On stainless steel pumps, apply anti-seize lubricant to the threads of the connector (51).

Repairing the Air Motor and Piston

NOTE: Parts marked with an asterisk are included in a repair kit, for example, (23*). See page 28 for repair kit part numbers. Use all the parts in the kit for the best results.

Disassembly



1. Relieve the pressure. Follow the **Pressure Relief Procedure** on page 11.
2. Disassemble the pump as instructed under **Repairing the Fluid Piston and Seal**.
3. Remove the screws (4), washers (2), nuts (1), and lock washers (2) from the cylinder cap (25).
4. Remove the pump from the mounting bracket (44).
5. Remove the cylinder cap (25) from each end of the air motor. If the hoses aren't disconnected or the pilot valves removed, be careful not to pull on the hoses when removing the caps.

NOTICE

The shaft wiper (21) and bearing (22) are meant to remain in place. Remove only to replace. Removal will damage them.

6. Remove the shaft wiper (21) and bearing (22) only if they need to be replaced. Remove the u-cup (23*) from each of the cylinder caps (25). Use a 0.875 in. diameter shaft to remove the bearing.
7. Remove the piston assembly (17) from the air motor cylinder (27). Remove the quad ring (28*).
8. Do not remove the piston shafts (15) unless replacement is necessary as a high strength sealant was used on the threads. If the rods must be removed, heating the joint to 300°F will ease disassembly. Place wrenches on the flats of the piston shaft to disconnect them from the piston stud (30).
9. Clean all parts and inspect for wear or damage. Replace as needed.

Assembly

1. Apply lithium base grease to all packings, seals, and the inside of the air motor cylinder (27) before assembling.
2. If the piston shafts (15) were removed from the piston stud (30), apply high strength sealant to the threads of the piston stud, and assemble.
3. Install the quad ring (28*) in the groove on the piston (29). Install the piston assembly (29) into the air motor cylinder (27).

NOTE: On 400 and 1200 series pumps, torque to 140 to 150 ft-lb (190 to 203 N•m). On 2500 series pumps, torque to 110 to 120 ft-lb (149 to 162 N•m). See the model and part number for specifications.

4. Install a u-cup (23*) into each of the cylinder caps (25). The lips of the u-cup must face in, towards the center of the pump.
5. If the bearings (22) were removed, install a bearing into each cylinder cap (25). Press fit the bearing to flush, using an arbor press.
6. Install a shaft wiper (21) into each cylinder cap (25) with the brass part of the wiper facing out, away from the center of the pump. Carefully press the wiper into place, taking care to avoid damaging the brass piece.
7. Install an o-ring (26*) into the groove in each of the cylinder caps (25). Slide a cylinder cap (25) onto each end of the air motor. Align flat edges with air valve.
8. Secure the mounting bracket (44) and cylinder caps (25) on the pump with the screws (4), washers (3), nuts (1), and lock washers (2). Torque the screws oppositely and evenly to 7.4 to 12.5 ft-lb (10 to 17 N•m).

Repair or Replace the Air Valve



Replace the Complete Air Valve

1. Stop the pump. Follow the **Pressure Relief Procedure**.
2. Disconnect the air line.
3. For models with DataTrak: Remove the screw to disconnect the reed switch assembly from the air valve. Then, remove two screws and the solenoid bracket. Pull the solenoid out of the air valve.
4. Remove the screws (43). Remove the air valve (40) and the gasket (91).
5. To repair the air valve, see **Replace Seals or Rebuild the Air Valve**.
6. Align the new air valve gasket (91) on the manifold, then attach the new or repaired air valve. See Torque Instructions.
7. For models with DataTrak: Remember to reattach the solenoid bracket and the solenoid. Then, use the screw to attach the reed switch assembly to the new air valve. Reconnect the cable.
8. Reconnect the air line.

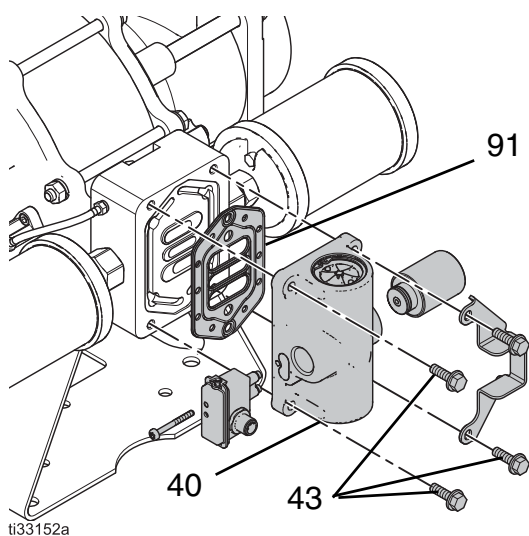

Replace Seals or Rebuild the Air Valve

See **Air Valve Parts** to find the correct repair kits for your pump. Parts in Air Valve Seal Kits are marked †. Parts in Air Valve Repair Kits are marked ◆. Parts in End Cap Kits are marked ❖.

Disassemble the Air Valve

1. Perform steps 1–4 under **Replace the Complete Air Valve**.
2. Use a T8 Torx screwdriver to remove the two screws (109). Remove the valve plate (105), the cup assembly (112–114), the spring (111), and the detent assembly (103).
3. Pull the cup (112) off of the base (114). Remove the o-ring (113) from the cup.
4. Remove the retaining ring (110) from each end of the air valve. Use the piston (102) to push the end caps (107, 117) out of the ends. Remove the end cap o-rings (106). If the pump model is equipped with DataTrak, also remove the solenoid release button (118) and o-ring (119).
5. Remove the u-cup seals (108) from each end of the piston (102), then remove the piston. Remove the detent cam (104) from the air valve housing (101).

Reassemble the Air Valve

NOTE: Apply lithium-based grease whenever instructed to grease.

1. Use all parts in the repair kits. Clean other parts and inspect for damage. Replace as needed.
2. Grease the detent cam (104) and install it into the housing (101).

- Grease the u-cups (108) and install on the piston (102) with the lips facing toward the center of the piston.

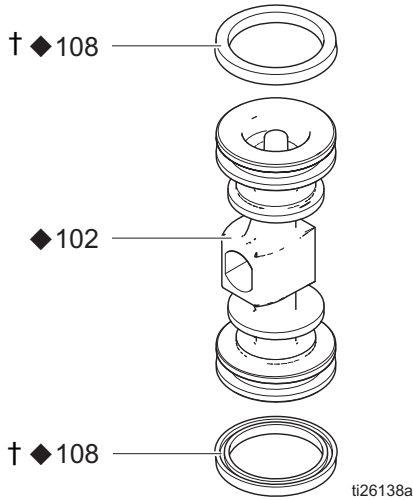

- Grease both ends of the piston (102) and install it in the housing (101), with the flat side toward the cup. Be careful not to tear the u-cups (108) when sliding the piston into the housing.
- Standard Models:** Grease the new o-rings (106) and install them on the end caps (107). Install the end caps into the housing.

DataTrak Models: Orient the air valve so the air inlet faces forward. Grease and install a new o-ring (106) on the right-side end cap (107). Grease and install a new o-ring (106) and the solenoid release button (118) and o-ring (119) on the left-side end cap (117). Install the end caps into the housing.

- Install a retaining ring (110) on each end to hold the caps in place.
- Grease and install the detent assembly (103) into the piston.

- Install the o-ring (113) on the cup (112). Apply a light film of grease to the outside surface of the o-ring and the inside mating surface of the base (114). Orient the end of the base that has a magnet toward the end of the cup that has the larger cutout. Engage the opposite end of the parts. Leave the end with the magnet free. Tilt the base toward the cup and fully engage the parts, ensuring that the o-ring remains in place. Install the spring (111) onto the protrusion on the cup. align the magnet in the base with the air inlet and install the cup assembly.

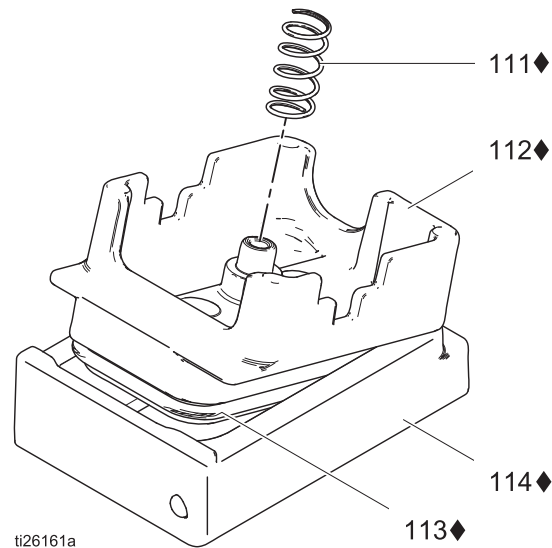

- Grease the cup side, and install the valve plate (105). Align the small hole in the plate with the air inlet. Tighten the screws (109) to hold it in place.

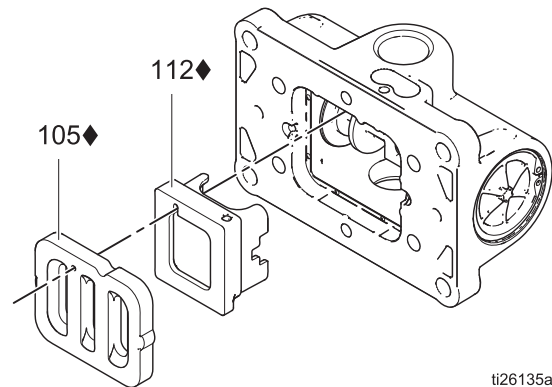

Air Valve Disassembly or Reassembly

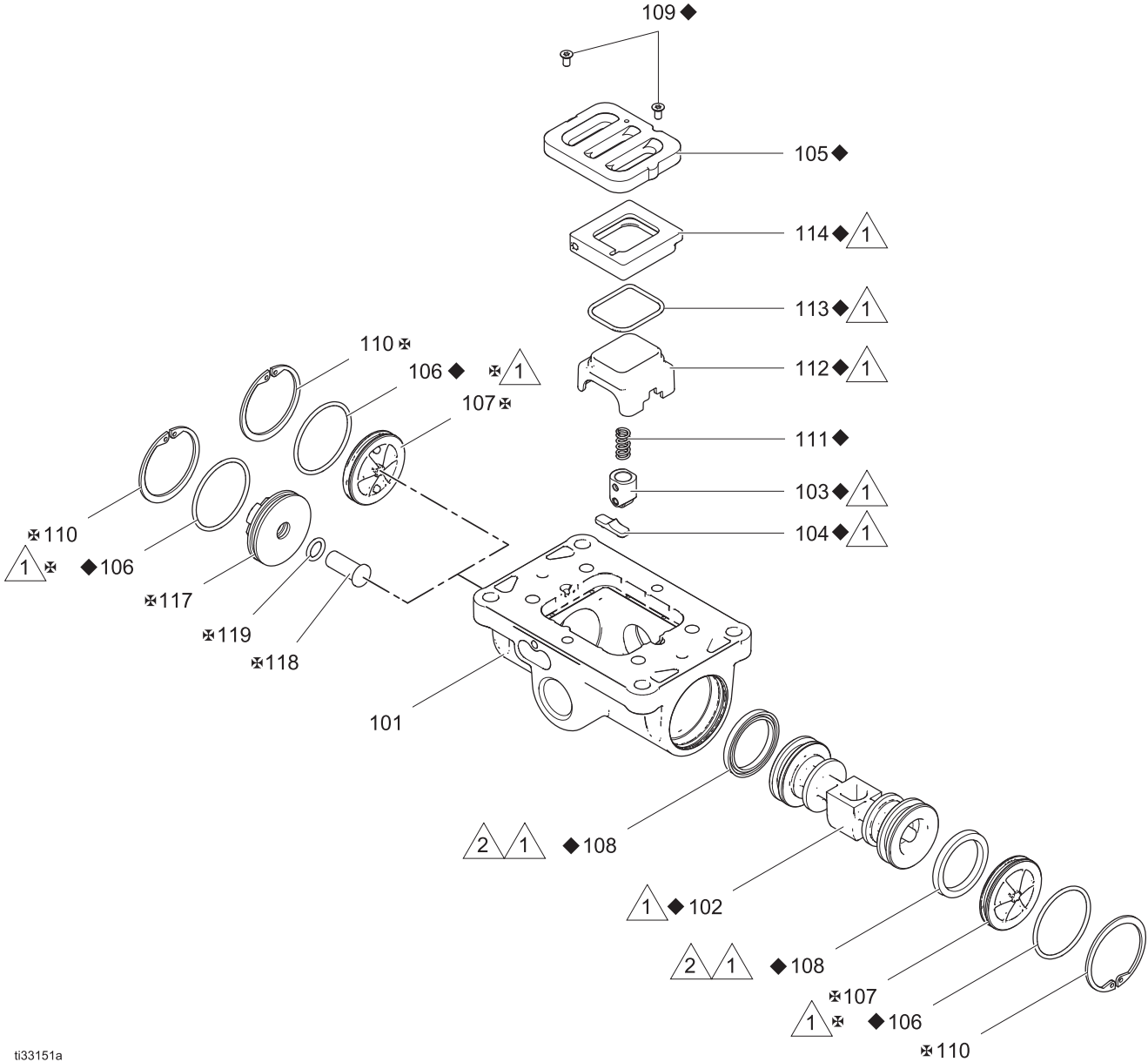

t33151a

- 1 Apply lithium-based grease.
- 2 U-cup lips must face the piston.

DataTrak

NOTE: See DataTrak manual, 313840, for all DataTrak service, repair and operation information.

Replace DataTrak Battery or Fuse



To reduce the risk of fire and explosion, the battery and fuse must be replaced in a non-hazardous location. Follow all instructions in the DataTrak manual 313840.

Use only an approved replacement battery, and an approved fuse. See the DataTrak manual. Use of an unapproved battery or fuse will void Graco's warranty and Ex approvals.

Parts

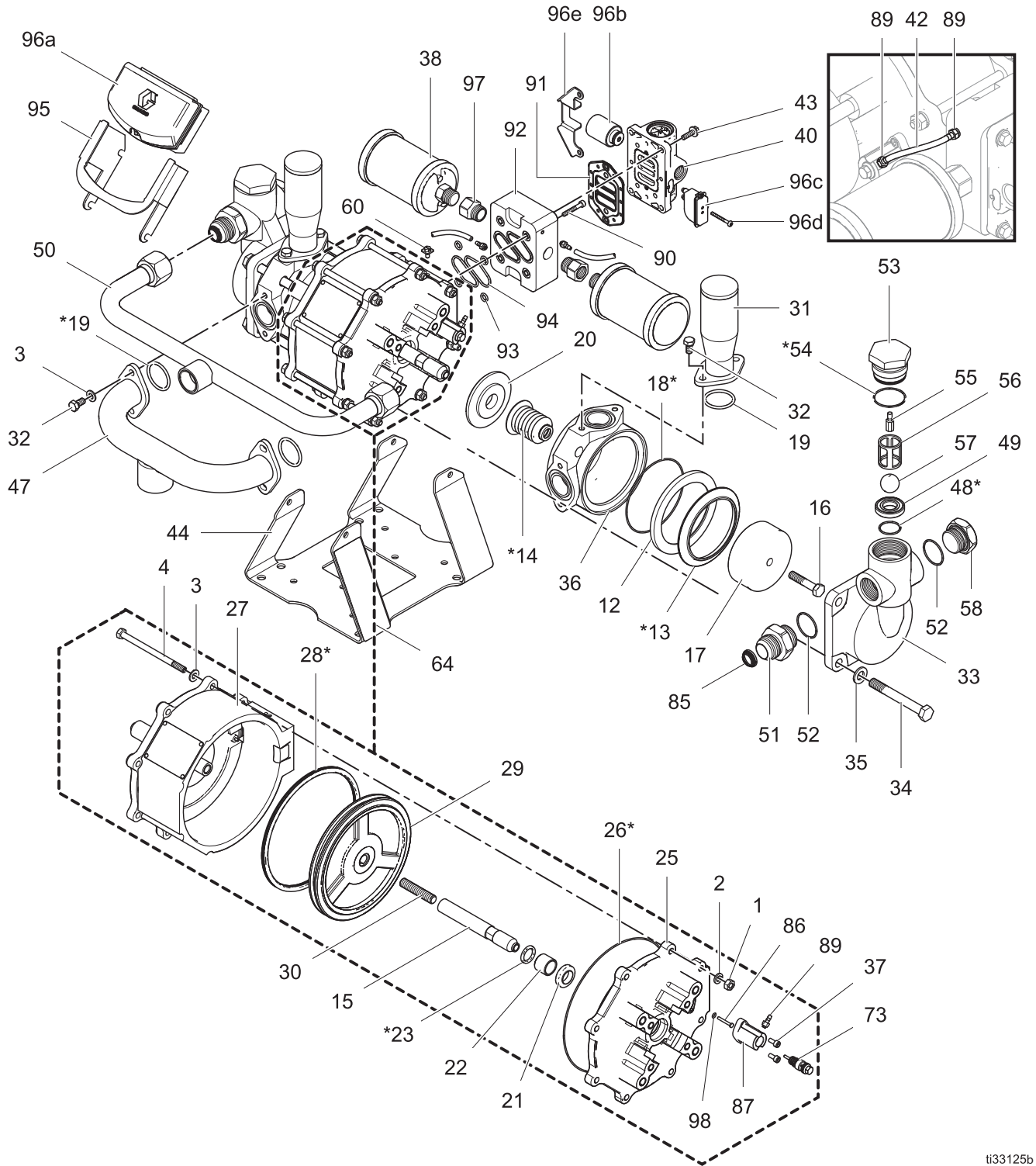

t133125b

Parts

Ref. No.	Part No.	Description	Qty.
1	108712	NUT, hex; M8 x 1.25	8
2	104572	WASHER, spring lock	8
3	-----	WASHER, M8	12
4	108786	SCREW, cap, hex hd; M8 x 1.25 x 130	8
12	181974	PLATE, retaining (4:1)	2
	181973	PLATE, retaining (12:1)	2
	185940	PLATE, retaining (25:1)	2
13*	181978	SEAL, piston; UHMWPE (4:1)	2
	188177	SEAL, piston; Nylon (4:1)	2
	183240	SEAL, piston; UHMWPE (12:1)	2
	188178	SEAL, piston; Nylon (12:1)	2
	181959	SEAL, piston; UHMWPE (25:1)	2
	188176	SEAL, piston; Nylon (25:1)	2
14*	15U077	SEAL, bellows; UHMW	2
15	181951	SHAFT, piston	2
16	108652	SCREW, cap, hex hd; M10 x 1.5 x 50	2
17	189432	PISTON, pump; 17-4 PH stainless steel, hard chrome (4:1)	2
	189433	PISTON, pump; 17-4 PH stainless steel, hard chrome (12:1)	2
	189434	PISTON, pump; 17-4 PH stainless steel, hard chrome (25:1)	2
18*	108824	O-RING; PTFE (4:1, 12:1)	2
	108823	O-RING; PTFE (25:1)	2
19*	108825	O-RING; PTFE (4:1, 12:1)	4
		O-RING; PTFE (25:1)	2
20	181967	PLATE, retaining; stainless steel	2
21	108713	WIPER, shaft	2
22	183228	BEARING	2
23*	108158	U-CUP; buna-N	2
25	183098	CAP, cylinder	2
26*	108874	O-RING; buna-N	2
27	183097	CYLINDER, air motor	1
28*	107160	QUAD RING; buna-N	1
29	183355	PISTON, air motor	1
30	183229	STUD	1
31	181998	ACCUMULATOR, CS (4:1)	2
	220971	ACCUMULATOR, SST (12:1)	2
32	108768	SCREW, cap, hex hd; M8 x 1.25 x 16, CS	8
	108768	SCREW, cap, hex hd; M8 x 1.25 x 16 (4:1, 12:1, 8x)	8
	108791	SCREW, cap, hex hd; M8 x 1.25 x 16, SST	8
	108791	SCREW, cap, hex hd; M8 x 1.25 x 16 (25:1, 4x)	8

Ref. No.	Part No.	Description	Qty.
33	181846	HOUSING, pump outlet, CS (4:1)	2
	181864	HOUSING, pump outlet, SST (4:1)	2
	181854	HOUSING, pump outlet, CS (12:1)	2
	181866	HOUSING, pump outlet, SST (12:1)	2
	185554	HOUSING, pump outlet, SST (25:1)	2
34	108793	SCREW, cap, hex hd; SST; M12 x 1.75 x 100 (4:1, 12:1)	8
	110622	SCREW, cap, hex hd; SST; M10 x 1.5 x 100 (25:1)	8
35	111449	WASHER, M12 (4:1, 12:1)	8
	100731	WASHER, M10 (25:1)	8
36	181847	HOUSING, pump intake CS (4:1, 12:1)	2
	181865	HOUSING, pump intake SST (4:1, 12:1)	2
	185555	HOUSING, pump intake SST (25:1)	2
37	107100	SCREW, cap, hex sch; M5 x 0.8 x 12	4
38	117237	MUFFLER	2
40	24B744	AIR VALVE, Standard	1
	24B745	AIR VALVE, Advanced	1
42	17W201	TUBE, 0.25 in. (6.35 mm) O.D.; polyurethane	2
43	15R553	SCREW, cap, hex hd; M5 x 0.8 x 20	4
44	181950	BRACKET, mounting	1
47	220486	INTAKE MANIFOLD, CS	1
	220490	INTAKE MANIFOLD, SST	1
48*	103341	O-RING; PTFE (4:1, 12:1)	2
	107313	O-RING; PTFE (25:1)	2
49	181947	SEAT, valve, CS (4:1, 12:1)	2
	220948	SEAT, valve, SST (4:1, 12:1)	2
	189067	SEAT, valve, SST (25:1)	2
50	220485	MANIFOLD, CS (4:1, 12:1)	1
	220491	MANIFOLD, SST (4:1, 12:1)	1
51	108647	CONNECTOR, straight thread, SST (4:1, 12:1)	2
	185553	CONNECTOR, straight thread, SST (25:1)	2
52*	107098	O-RING; PTFE (4:1, 12:1)	4
	108526	O-RING; PTFE (25:1)	4
53	181949	CAP, CS	2
	181969	CAP, SST	2
54*	108822	O-RING; PTFE	2
55	181976	STOP, ball; stainless steel (4:1, 12:1)	2
	185552	STOP, ball; stainless steel (25:1)	2
56	181845	GUIDE, ball; stainless steel (4:1, 12:1)	2
	181852	GUIDE, ball; stainless steel (25:1)	2

Ref. No.	Part No.	Description	Qty.
57	107167	BALL; stainless steel, CS (4:1, 12:1)	2
	101822	BALL; stainless steel (25:1)	2
	108287	BALL; stainless steel, SST (4:1, 12:1)	2
58	108644	PLUG, boss (4:1, 12:1)	2
	101822	PLUG, boss (25:1)	2
60	116343	LUG, grounding	1
64 ▲	183429	LABEL, warning	1
73	247391	PILOT VALVE ASSEMBLY	2
85	16F143	SEAL, hydraulic (4:1)	2
	16F142	SEAL, hydraulic (25:1)	2
86	17T610	PIN, valve, pilot	2
87	17T609	ADAPTER, pilot	2
89	108383	FITTING, barb	4
90	117127	SCREW, SHCS M5x35	4
91	16F429	GASKET, air valve	1
92	17T612	ADAPTER, valve	1
93	159589	PACKING, o-ring	4
94	107550	PACKING, o-ring	2
95	17U948	BRACKET, DataTrak	1
96	24X309	DataTrak	1
96a	-----	ENCLOSURE, DataTrak	
96b	-----	SCREW, pan head, hi-lo	
96c	-----	REED SWITCH, assembly with solenoid	
96d	-----	FASTENER, screw slot hex, #8-32	
96e	-----	BRACKET, solenoid	
97	15T560	ADAPTER, muffler	2
98	106555	PACKING, o-ring	2

* Parts included in the following repair kits, which may be purchased separately:

24C130 (for 12:1 UHMWPE models)

24C131 (for 12:1 nylon models)

24C132 (for 25:1 UHMWPE models)

24C133 (for 25:1 nylon model)

24C134 (for 4:1 UHMWPE models)

24C135 (for 4:1 nylon models)

See **Air Valve Parts** for a description of all available Repair Kits, Optional Repair Kits, and Conversion Kits.

▲ Replacement Danger and Warning labels, tags, and cards are available at no cost.

Air Valve Parts

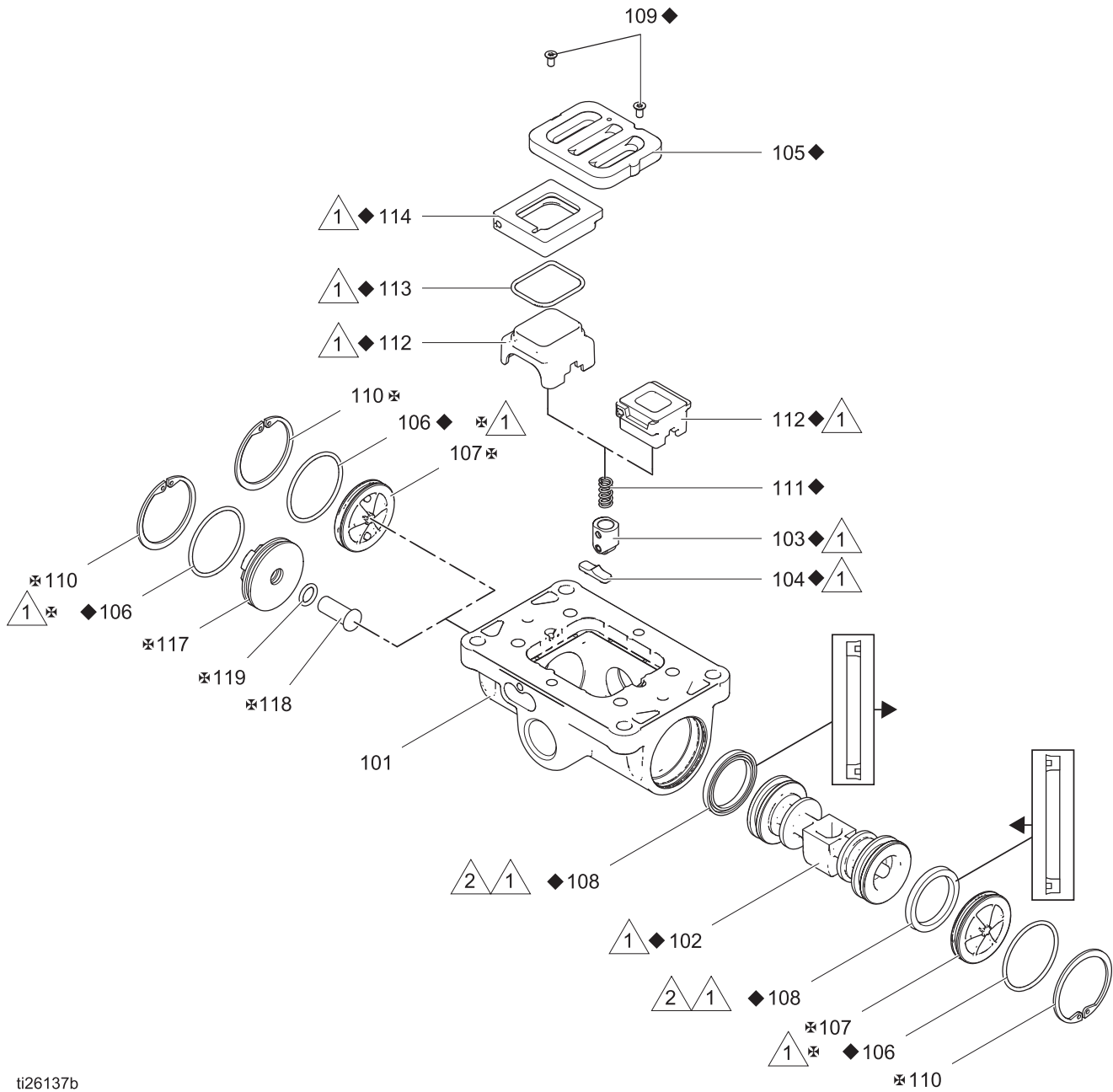

ti26137b

Air Valve Parts

Ref.	Description	Qty.
101	HOUSING	1
102◆	AIR VALVE PISTON	1
103◆	DETENT PISTON ASSEMBLY	1
104◆	DETENT CAM	1
105◆	PLATE, air valve	1
106◆†❖	O-RING	2
107❖	CAP, Standard	2
	CAP, Compatible with DataTrak models with runaway protection	1
108◆†	U-CUP	2
109◆†	SCREW	2
110❖	SNAP RING	2
111◆	DETENT SPRING	1
112◆	CUP, One-Piece	1
	CUP, Three-Piece, with refs. 113 and 114	1
113◆	O-RING (for cup, ref. 112)	1
114◆	BASE (for cup, ref. 112)	1
117❖	CAP (for DataTrak models with runaway protection)	1
118❖	BUTTON (for DataTrak models with runaway protection)	1
119❖	O-RING (for DataTrak models with runaway protection)	1
13◆†	GASKET, air valve	1

◆ Included in Air Valve Repair Kit and 24A538.

† Included in Air Valve Seal Kit and 24A536.

❖ Included in Air Valve End Cap Kit. See **Repair and Conversion Kits**.

Repair and Conversion Kits

Kit Description	400 Series	1200 Series	2500 Series
Pump Urethane Piston Seal Conversion Kit	220658	---	220660
Standard Pump Repair Kit with UHMWPE Piston Seal	24C135	24C131	24C133
Standard Pump Repair Kit with Nylon Piston Seal	24C134	24C130	24C132
Pumps Carbide Ball and Seat Conversion Kit	221134	221134	221135
Ceramic Piston Kit	686499	---	---
Air Valve Conversion Kits for Series A-D	Standard: 17W667 Advanced: 17W668		
DataTrak Conversion Kit (for converting series D+ from standard to advanced)	24Y306		
Reed Switch (Cycle Count) Kit (for remote cycle counting without DataTrak)	17W772		

Accessories

Kit Description	Number
Suction Kit (55 Gallon Drum Size)	208259
Ground Wire and Clamp	222011
Wall Mount Bracket	255143
Wall Mount Adapter Kit	17W670

Performance Charts

400 Series Pumps

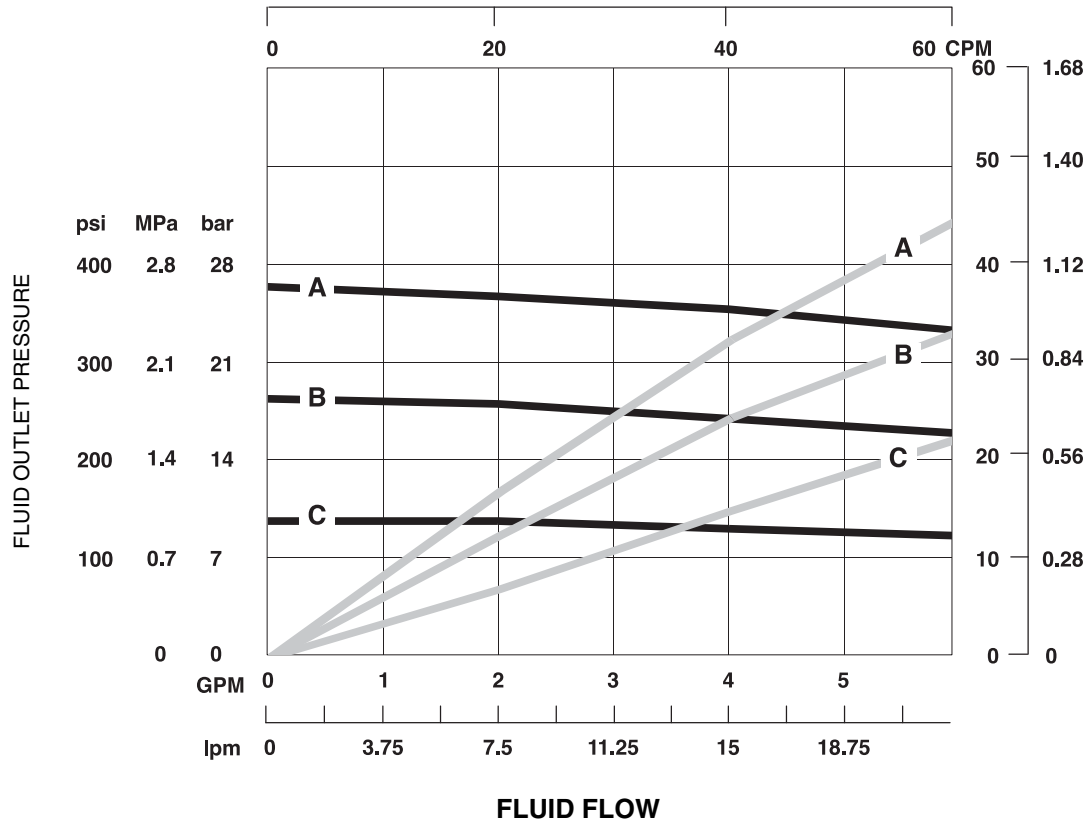

KEY: Fluid Outlet Pressure: black curves
 Air Consumption: gray curves
A at 100 psi (0.7 MPa, 7 bar) air pressure
B at 70 psi (0.48 MPa, 4.9 bar) air pressure
C at 40 psi (0.28 MPa, 2.8 bar) air pressure

To find outlet pressure (psi/MPa/bar) at a specific delivery (GPM, lpm) and operating air pressure (psi/MPa/bar):

1. Locate desired delivery along bottom of chart.
2. Read vertical line up to intersection with selected fluid outlet pressure curve. Follow left to scale and read outlet pressure.

To find pump air consumption (CFM, m³/min) specific delivery (GPM, lpm) and operating air pressure (psi/MPa/bar):

1. Locate desired delivery along bottom of chart.
2. Read vertical line up to intersection with selected air consumption curve. Follow right to scale and read air consumption.

1200 Series Pumps

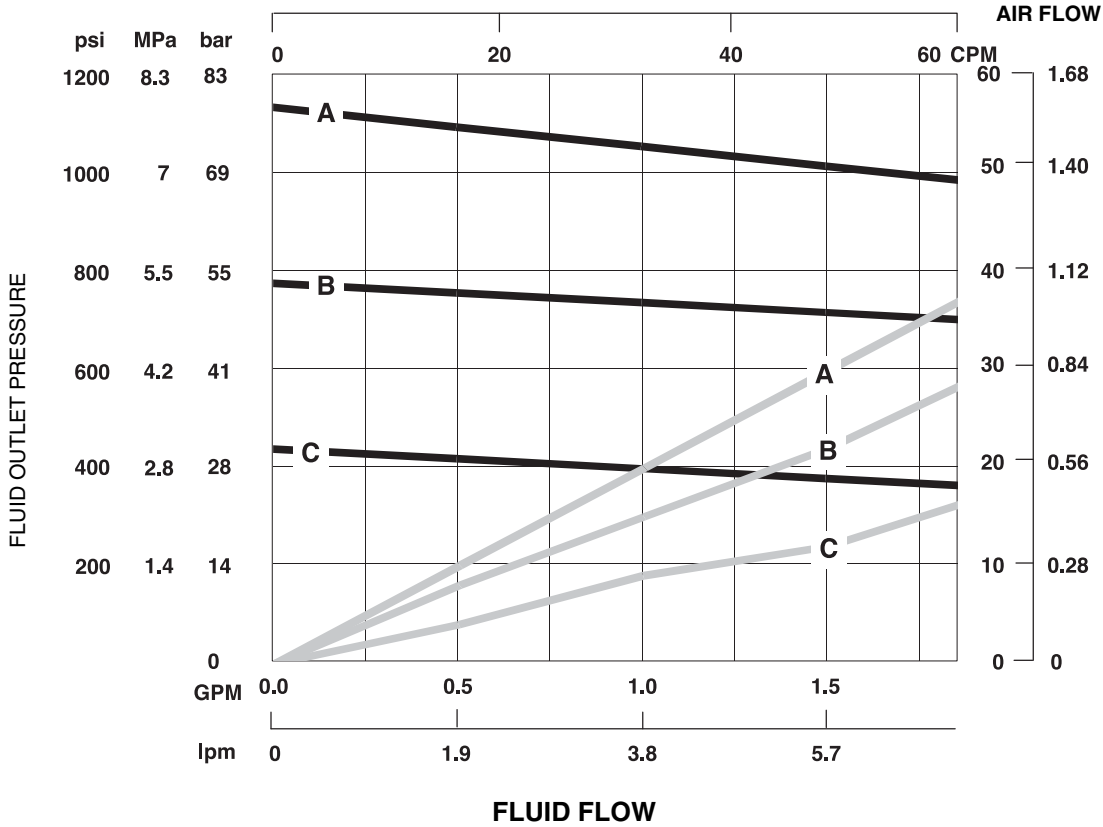

KEY: Fluid Outlet Pressure: black curves
 Air Consumption: gray curves
A at 100 psi (0.7 MPa, 7 bar) air pressure
B at 70 psi (0.48 MPa, 4.9 bar) air pressure
C at 40 psi (0.28 MPa, 2.8 bar) air pressure

To find outlet pressure (psi/MPa/bar) at a specific delivery (GPM, lpm) and operating air pressure (psi/MPa/bar):

1. Locate desired delivery along bottom of chart.
2. Read vertical line up to intersection with selected fluid outlet pressure curve. Follow left to scale and read outlet pressure.

To find pump air consumption (CFM, m3/min) specific delivery (GPM, lpm) and operating air pressure (psi/MPa/bar):

1. Locate desired delivery along bottom of chart.
2. Read vertical line up to intersection with selected air consumption curve. Follow right to scale and read air consumption.

2500 Series Pumps

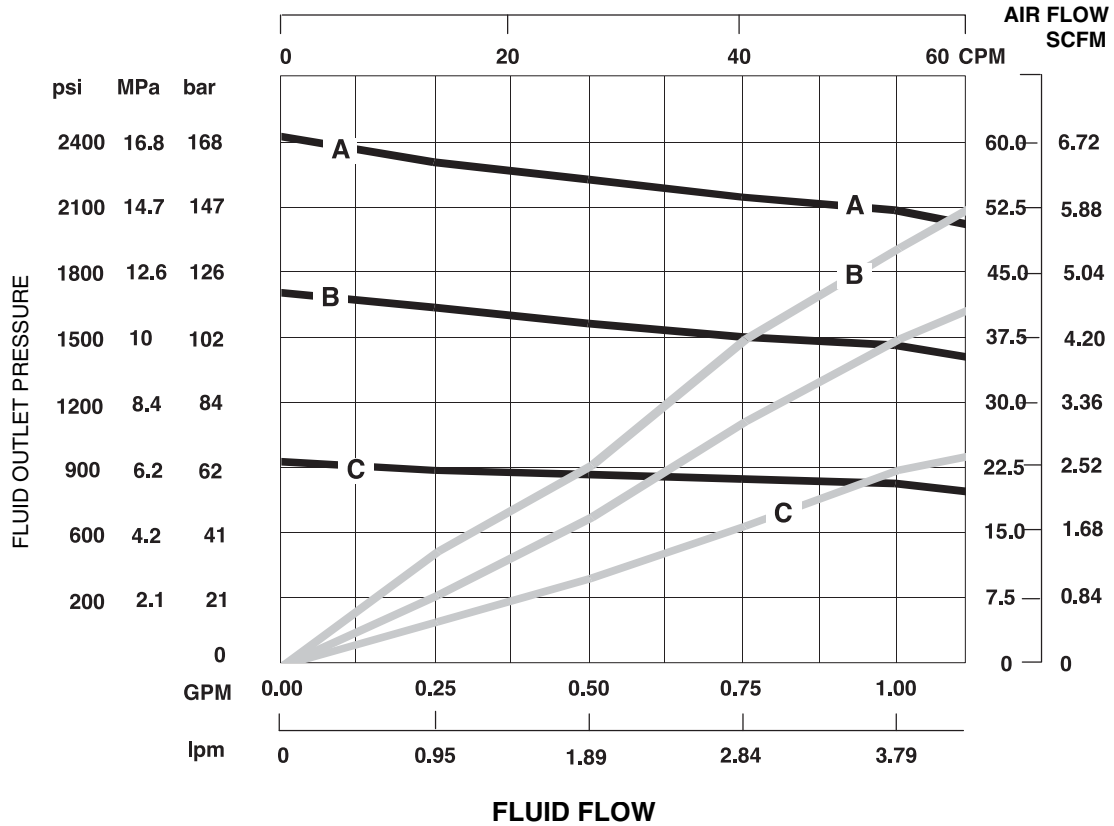

KEY: Fluid Outlet Pressure: black curves
 Air Consumption: gray curves
A at 100 psi (0.7 MPa, 7 bar) air pressure
B at 70 psi (0.48 MPa, 4.9 bar) air pressure
C at 40 psi (0.28 MPa, 2.8 bar) air pressure

To find outlet pressure (psi/MPa/bar) at a specific delivery (GPM, lpm) and operating air pressure (psi/MPa/bar):

1. Locate desired delivery along bottom of chart.
2. Read vertical line up to intersection with selected fluid outlet pressure curve. Follow left to scale and read outlet pressure.

To find pump air consumption (CFM, m3/min) specific delivery (GPM, lpm) and operating air pressure (psi/MPa/bar):

1. Locate desired delivery along bottom of chart.
2. Read vertical line up to intersection with selected air consumption curve. Follow right to scale and read air consumption.

Dimensions and Mounting Hole Layout

Dimensions:

- 1 Height 400 and 1200 Series pumps: 15.1 in. (384 mm)
 2500 Series pumps: 12.6 in. (320 mm)
- 2 Width: 19.6 in. (498 mm)
- 3 Depth: 15.83 in. (401 mm)
- 4 Air inlet: 1/2 npt(f)
- 5 Fluid inlet: 1.25 npt(f)
- 6 Fluid outlet: 400 and 1200 Series pumps: 1 npt(f)
 2500 Series pumps: 3/4 npt(f)

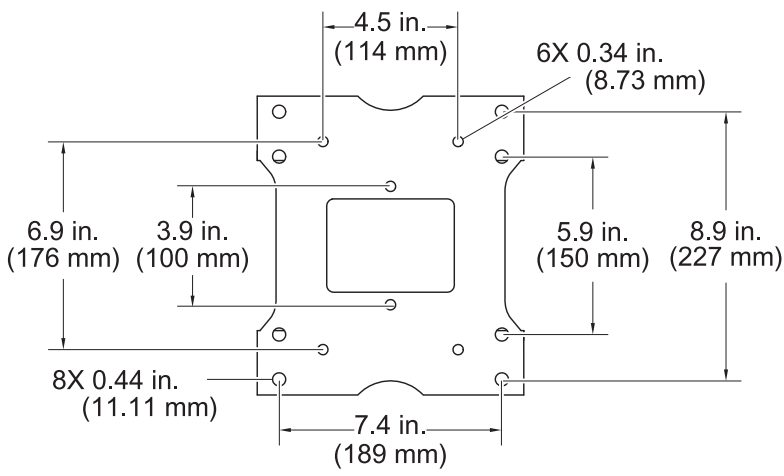
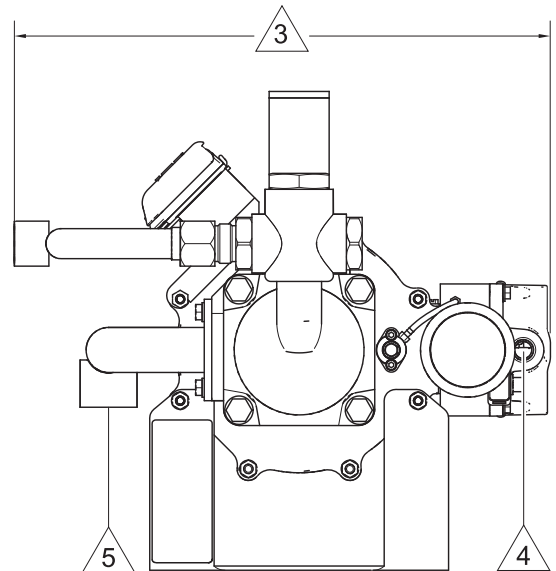
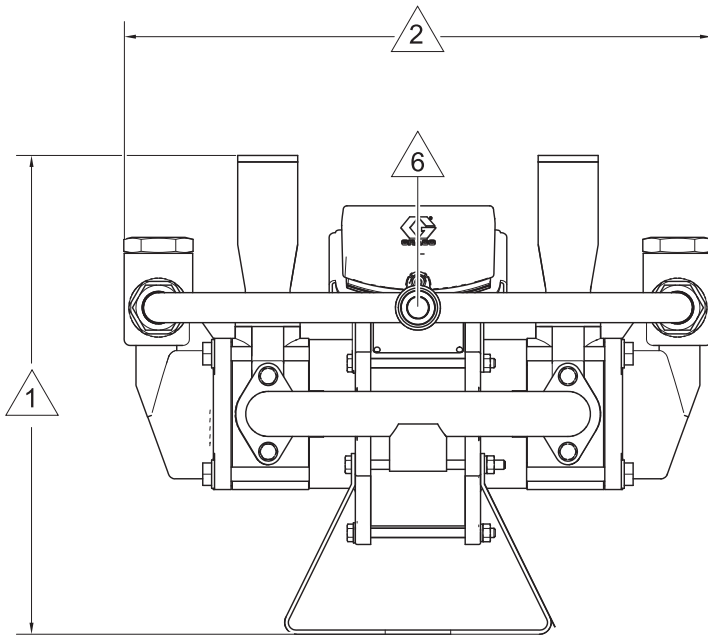

t33171a

Technical Specifications

	U.S.	Metric
Maximum Working Pressure		
400 Series	400 psi	2.8 MPa, 28 bar
1200 Series	1200 psi	8.3 MPa, 83 bar
2500 Series	2500 psi	17 MPa, 170 bar
Maximum Air Input Pressure		
400 Series	100 psi	0.7 MPa, 7 bar
1200 Series		
2500 Series		
Air Operating Range		
400 Series	15 to 100 psi	0.1 to 0.7 MPa, 1 to 7 bar
1200 Series		
2500 Series		
Maximum Continuous Pump Speed		
400 Series	60 cpm	
1200 Series		
2500 Series		
Fluid Flow at 60 cpm		
400 Series	5.6 gpm	21.2 lpm
1200 Series	2 gpm	7.5 lpm
2500 Series	0.9 gpm	3.4 lpm
Fluid Volume Per Cycle		
400 Series	0.096 gal	0.366 liter
1200 Series	0.034 gal	0.128 liter
2500 Series	0.015 gal	0.058 liter
Maximum Suction Life (Water)		
400 Series	15 ft	4.57 m
1200 Series	15 ft	4.57 m
2500 Series	6 ft	1.83 m
Maximum Fluid Operating Temperature		
400 Series	150°F	65°C
1200 Series		
2500 Series		

	U.S.	Metric
Air Inlet		
400 Series	1/2 npt(f)	
1200 Series		
2500 Series		
Fluid Inlet		
400 Series	1.25 npt(f)	
1200 Series		
2500 Series		
Fluid Outlet		
400 Series	1 npt(f)	
1200 Series	1 npt(f)	
2500 Series	3/4 npt(f)	
Weight		
400 Series	80.5 lb	36.2 kg
1200 Series	78 lb	35.1 kg
2500 Series	77 lb	34.9 kg
Wetted Parts		
Carbon steel, UHMWPE seal • 400 Series • 1200 Series	carbon steel, stainless steel, ultra high molecular weight polyethylene, PTFE	
Carbon steel, nylon seal • 400 Series • 1200 Series	carbon steel, stainless steel, ultra high molecular weight polyethylene, Nylon, PTFE	
Stainless steel, UHMWPE seal • 400 Series • 1200 Series • 2500 Series	304 and 316 stainless steel, 17-4 PH stainless steel, ultra high molecular weight polyethylene, PTFE	
Stainless steel, nylon seal • 400 Series • 1200 Series • 2500 Series	304 and 316 stainless steel, 17-4 PH stainless steel, ultra high molecular weight polyethylene, Nylon, PTFE	
Noise Data		
Sound power*	78.8 dBA	
Sound pressure**	68.9 dBA	

* Sound power at 70 psi (0.48 MPa, 4.8 bar), 20 cpm. Sound power measured per ISO-9614-2.

** Sound pressure was tested 3.28 feet (1 m) from equipment.

Graco Standard Warranty

Graco warrants all equipment referenced in this document which is manufactured by Graco and bearing its name to be free from defects in material and workmanship on the date of sale to the original purchaser for use. With the exception of any special, extended, or limited warranty published by Graco, Graco will, for a period of twelve months from the date of sale, repair or replace any part of the equipment determined by Graco to be defective. This warranty applies only when the equipment is installed, operated and maintained in accordance with Graco's written recommendations.

This warranty does not cover, and Graco shall not be liable for general wear and tear, or any malfunction, damage or wear caused by faulty installation, misapplication, abrasion, corrosion, inadequate or improper maintenance, negligence, accident, tampering, or substitution of non-Graco component parts. Nor shall Graco be liable for malfunction, damage or wear caused by the incompatibility of Graco equipment with structures, accessories, equipment or materials not supplied by Graco, or the improper design, manufacture, installation, operation or maintenance of structures, accessories, equipment or materials not supplied by Graco.

This warranty is conditioned upon the prepaid return of the equipment claimed to be defective to an authorized Graco distributor for verification of the claimed defect. If the claimed defect is verified, Graco will repair or replace free of charge any defective parts. The equipment will be returned to the original purchaser transportation prepaid. If inspection of the equipment does not disclose any defect in material or workmanship, repairs will be made at a reasonable charge, which charges may include the costs of parts, labor, and transportation.

THIS WARRANTY IS EXCLUSIVE, AND IS IN LIEU OF ANY OTHER WARRANTIES, EXPRESS OR IMPLIED, INCLUDING BUT NOT LIMITED TO WARRANTY OF MERCHANTABILITY OR WARRANTY OF FITNESS FOR A PARTICULAR PURPOSE.

Graco's sole obligation and buyer's sole remedy for any breach of warranty shall be as set forth above. The buyer agrees that no other remedy (including, but not limited to, incidental or consequential damages for lost profits, lost sales, injury to person or property, or any other incidental or consequential loss) shall be available. Any action for breach of warranty must be brought within two (2) years of the date of sale.

GRACO MAKES NO WARRANTY, AND DISCLAIMS ALL IMPLIED WARRANTIES OF MERCHANTABILITY AND FITNESS FOR A PARTICULAR PURPOSE, IN CONNECTION WITH ACCESSORIES, EQUIPMENT, MATERIALS OR COMPONENTS SOLD BUT NOT MANUFACTURED BY GRACO. These items sold, but not manufactured by Graco (such as electric motors, switches, hose, etc.), are subject to the warranty, if any, of their manufacturer. Graco will provide purchaser with reasonable assistance in making any claim for breach of these warranties.

In no event will Graco be liable for indirect, incidental, special or consequential damages resulting from Graco supplying equipment hereunder, or the furnishing, performance, or use of any products or other goods sold hereto, whether due to a breach of contract, breach of warranty, the negligence of Graco, or otherwise.

FOR GRACO CANADA CUSTOMERS

The Parties acknowledge that they have required that the present document, as well as all documents, notices and legal proceedings entered into, given or instituted pursuant hereto or relating directly or indirectly hereto, be drawn up in English. Les parties reconnaissent avoir convenu que la rédaction du présente document sera en Anglais, ainsi que tous documents, avis et procédures judiciaires exécutés, donnés ou intentés, à la suite de ou en rapport, directement ou indirectement, avec les procédures concernées.

Graco Information

For the latest information about Graco products, visit www.graco.com.

For patent information, see www.graco.com/patents.

TO PLACE AN ORDER, contact your Graco distributor or call to identify the nearest distributor.

Phone: 612-623-6921 **or Toll Free:** 1-800-328-0211 **Fax:** 612-378-3505

All written and visual data contained in this document reflects the latest product information available at the time of publication. Graco reserves the right to make changes at any time without notice.

Original instructions. This manual contains English. MM 333022

Graco Headquarters: Minneapolis

International Offices: Belgium, China, Japan, Korea

GRACO INC. AND SUBSIDIARIES • P.O. BOX 1441 • MINNEAPOLIS MN 55440-1441 • USA

Copyright 2015, Graco Inc. All Graco manufacturing locations are registered to ISO 9001.

www.graco.com

Revision ZAL, October 2018