

LineLazer™ V 200HS Airless Line Stripers

Standard Series and High Production (HP) Auto Series

3A3390C

EN

***sFor the application of line striping materials.
For professional use only.
For outdoor use only.
Not for use in explosive atmospheres or hazardous locations.***

Maximum Operating Pressure: 3300 psi (22.8 MPa, 228 bar)



Important Safety Instructions

Read all warnings and instructions in this manual and in related manuals.
Be familiar with the controls and the proper usage of the equipment.
Save these instructions.

Related Manuals:	
3A3426	Operation
311254	Gun
309277	Pump
3A3428	Auto-Layout Applications Methods

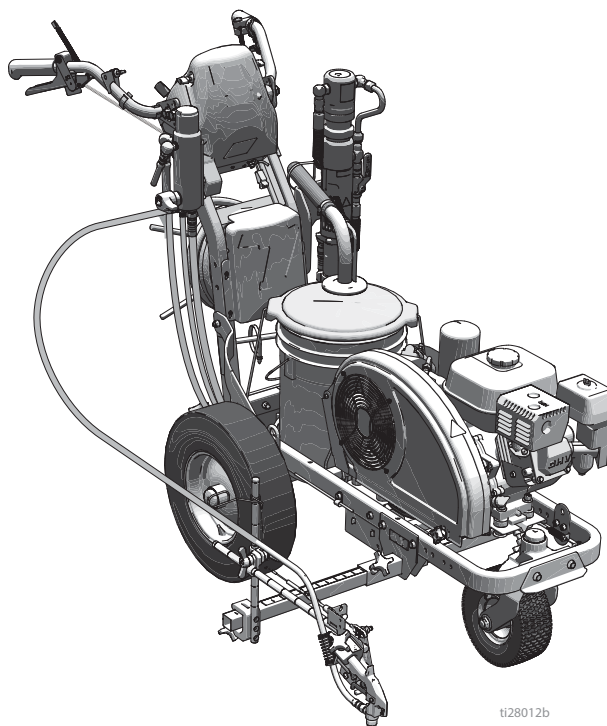

ti28012b

*Use only genuine Graco replacement parts.
The use of non-Graco replacement parts may void warranty.*



Contents

Tip Selection	4
LineLazer V 200HS Parts	5
Parts Drawing - LineLazer V 200HS	6
Parts List	7
Parts Drawing - LineLazer V 200HS	8
Parts List	9
Gun Holder and Arm	9
Gun Trigger	9
Parts Drawing - LineLazer V 200HS	10
Parts List	11
Handle/Controls	11
Filter	11
Parts Drawing - LineLazer V 200HS	13
Parts List	15
Parts Drawing - LineLazer V 200HS	16
Parts List	17
Wiring Diagram (Standard Series)	18
Wiring Diagram (HP Auto Series/HP Reflective Series)	19
Technical Specifications	20
Notes	23
Parts Drawing - LineLazer V 200HS	24
Parts List	24
Graco Standard Warranty	24
Graco Information	24



Manual	Language
3A3390	English
3A3813	French
3A3814	Spanish
3A3820	Dutch
3A3824	German
3A3827	Italian
3A3837	Turkish
3A3825	Greek
3A3818	Croatian
3A3832	Portuguese
3A3820	Danish
3A3823	Finnish
3A3836	Swedish
3A3830	Norwegian
3A3705	Russian
3A3822	Estonian
3A3828	Latvian
3A3829	Lithuanian
3A3831	Polish
3A3826	Hungarian
3A3829	Czech
3A3834	Slovakian
3A3835	Slovenian
3A3833	Romanian
3A3918	Bulgarian

Models

LineLazer V 200HS								
Model:	Standard 1 Manual Gun	Standard 2 Manual Guns	HP Auto 1 Auto Gun	HP Auto 1 Manual Gun 1 Auto Gun	HP Auto 2 Auto Guns	HP Reflective 1 Manual Gun 1 PBS Tank	HP Reflective 1 Auto Gun 1 PBS Tank	HP Reflective 2 Auto Guns 1 PBS Tank
17H459	✓							
17H461		✓						
17K582			✓					
17H462			✓ with laser					
17K637				✓				
17H463				✓ with laser				
17K583					✓			
17H464					✓ with laser			
17H460						✓		
17J964							✓	
17K585								✓
17H465								✓ with laser

* All auto guns can be actuated manually.

Tip Selection

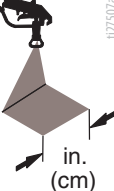
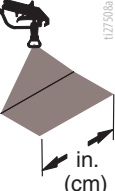
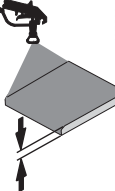
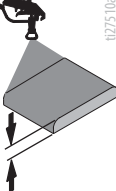
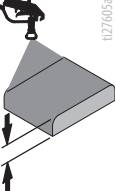
 1127506a	 1127505a in. (cm)	 1127506a in. (cm)	 1127507a in. (cm)	 1127508a in. (cm)	 1127509a	 1127510a	 1127605a
LL5213*	2 (5)				✓		
LL5215*	2 (5)					✓	
LL5217		4 (10)				✓	
LL5219		4 (10)					✓
LL5315*		4 (10)			✓		
LL5317		4 (10)			✓		
LL5319		4 (10)				✓	
LL5321		4 (10)				✓	
LL5323		4 (10)				✓	
LL5325		4 (10)					✓
LL5327		4 (10)					✓
LL5329		4 (10)					✓
LL5331		4 (10)					✓
LL5333		4 (10)					✓
LL5335		4 (10)					✓
LL5355		4 (10)					✓
LL5417			6 (15)		✓		
LL5419			6 (15)		✓		
LL5421			6 (15)		✓		
LL5423			6 (15)			✓	
LL5425			6 (15)			✓	
LL5427			6 (15)			✓	
LL5429			6 (15)			✓	
LL5431			6 (15)				✓
LL5435			6 (15)				✓
LL5621				12 (30)	✓		
LL5623				12 (30)	✓		
LL5625				12 (30)	✓		
LL5627				12 (30)	✓		
LL5629				12 (30)	✓		
LL5631				12 (30)		✓	
LL5635				12 (30)		✓	
LL5639				12 (30)			✓

* Use 100 mesh filter to reduce tip clogs.

LineLazer V 200HS Parts

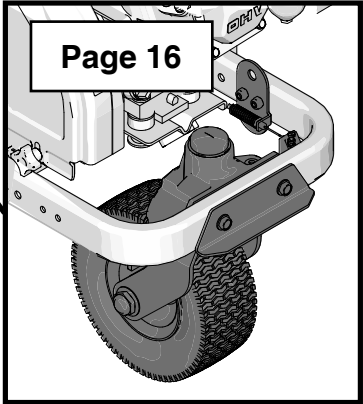
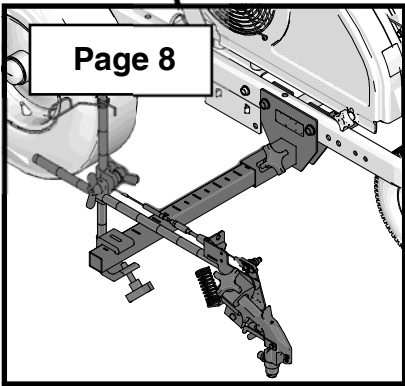
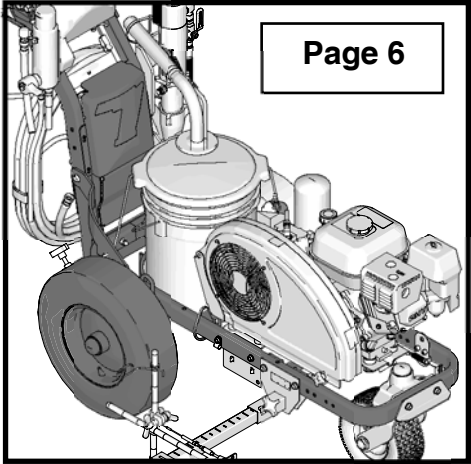
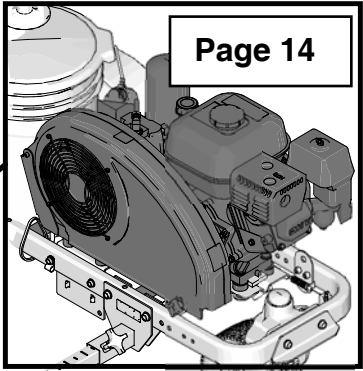
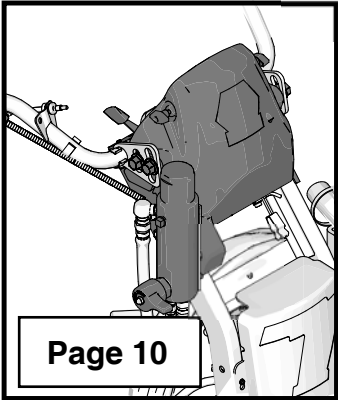
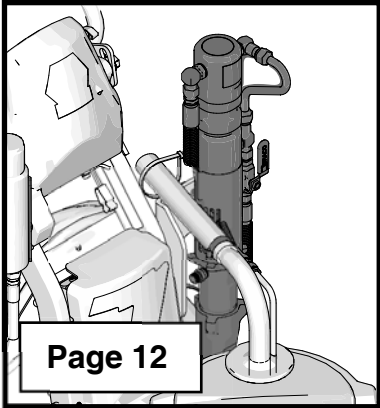
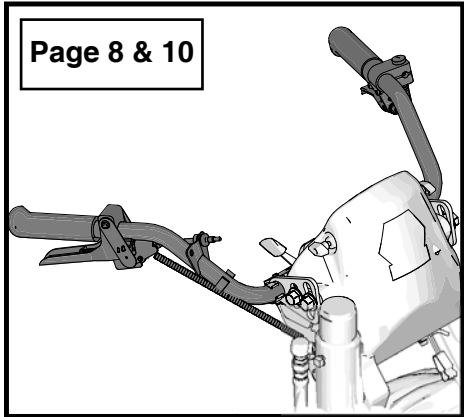

ti28065a

Parts Drawing - LineLazer V 200HS

- ▲ Torque to 45-55 ft-lbs
(61.0-74.5 N·m)
- ▲ Torque to 17-23 ft-lbs
(23.0-31.1 N·m)
- ▲ Rear tire pressure 58-62 psi
(3.9-4.2 bar)
- ▲ Torque to 190-210 in-lbs
(21.4-23.7 N·m)
- ▲ Torque to 130-150 in-lbs
(14.6-16.9 N·m)

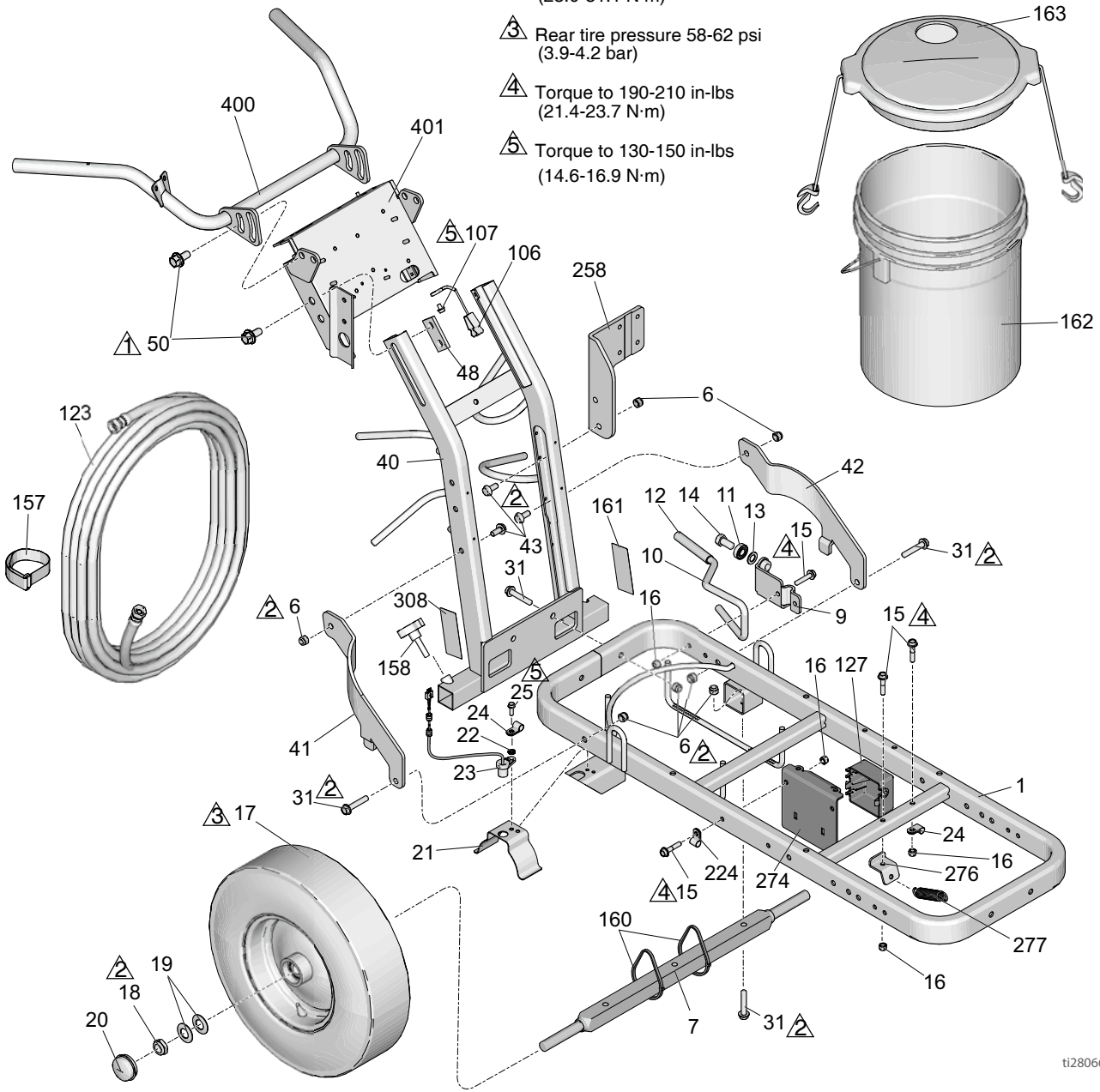

ti28066a

Parts List

Ref	Part	Description	Qty	Ref	Part	Description	Qty
1	237623	FRAME, linstriper, painted	1	43	128977	SCREW, cap button hd	4
6	101566	NUT, lock	12	48	17J125	BRACKET, slide	2
7	193405	AXLE	1	50	17J136	SCREW, hex, flange head	8
9	198891	BRACKET	1	106	237686	WIRE, ground	1
10	198930	ROD, brake (includes 12)	1	107	107257	SCREW, threat forming, hex hd	1
11	198931	BEARING	1	123	124884	HOSE, coupled, 3/8"x20'	1
12	114808	CAP, vinyl	1	127	15F369	BOX	1
13	195134	SPACER	1	157	114271	STRAP, retaining	1
14	113961	SCRE, cap, hex hd	1	158	108471	KNOB, pronged	1
15	112960	SCREW, flange, hex	5	160	404989	STRAP, tie	5
16	111040	NUT, lock, insert, nylock, 5/16	5	161▲	17K394	LABEL, gmax warning fire & skin	1
17	111020	WHEEL, pneumatic w/o sensor ring	1	162	115077	PAIL, plastic	1
	255162	WHEEL, pneumatic w/ sensor ring	1	163	24U241	KIT, pail, cover	1
18	112405	NUT, lock	2	224	17H721	CLAMP, wire	1
19	112825	WASHER	4	258	17H681	BRACKET, mount, pump, hydraulic	1
20	114648	CAP, dust	2	274	17J549	BRACKET, reservoir	1
21	15J088	SHIELD, distance sensor	1	276	15F441	BRACKET, frame	1
22	15K452	SPACER, round	1	277	119696	SPRING, extension	1
23	15K357	SENSOR, distance	1	308▲	17K392	LABEL, safety, warning	1
24	108868	CLAMP, wire	2	400	24Y641	BAR, handle	1
25	260212	SCREW, hex washer hd, thd form	2	401	24Y642	PLATE, control	1
31	114982	SCREW, cap, flng hd	6				
40	24Y665	FRAME, handle upright, painted	1				
41	15F576	BRACE, right, painted	1				
42	15F577	BRACE, left, painted	1				

▲ Replacement Warning Labels may be ordered free of charge.

Parts Drawing - LineLazer V 200HS

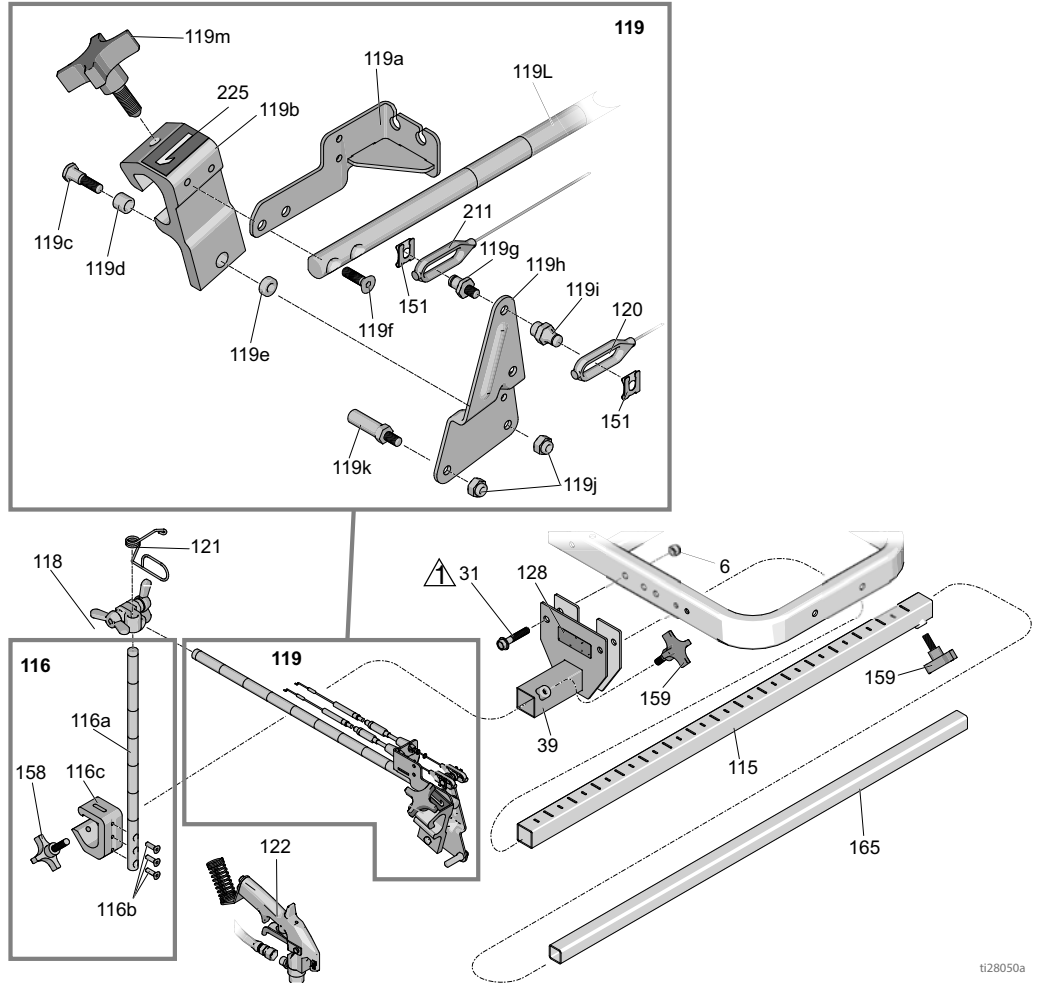

Torque to 17-23 ft-lbs
(23.0-31.1 N·m)

Torque to 18-22 in-lbs
(2.0-2.4 N·m)

ti28050a

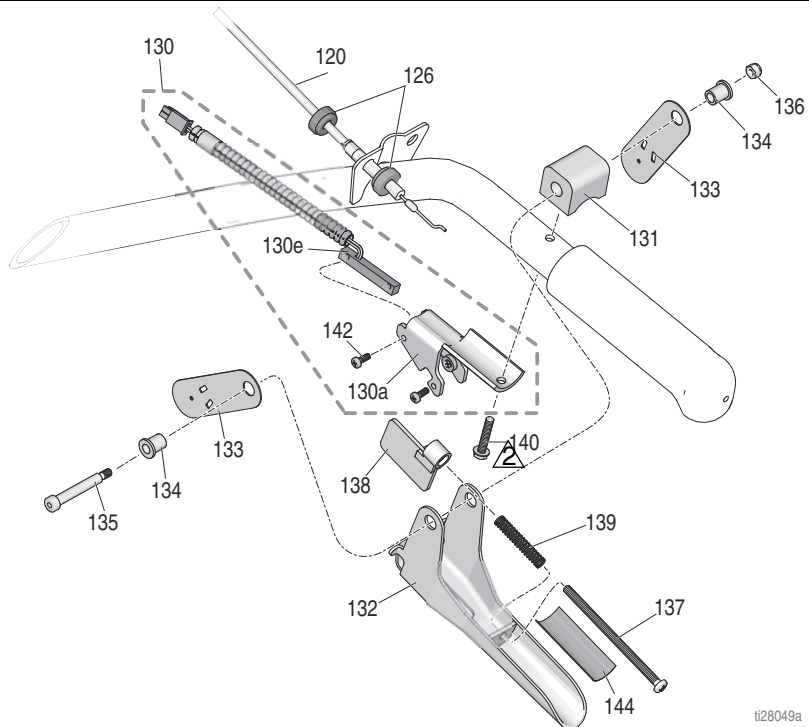

ti28049a

Parts List

Gun Holder and Arm

Ref.	Part	Description	Qty.
6	101566	NUT, lock	2
31	114982	SCREW, cap, flng hd	2
39	17H528	BRACKET, gun arm	1
115	17J407	ARM, extension, bar	1
116	17J424	BAR, height adjustment, assy	1
116a	17J139	BAR, gun, height, adjustment	1
116b	113428	SCREW, mach, hex, hd	3
116c	17J153	BRACKET, gun holder	1
118	24Y645	KIT, clamp, double wing nut	1
119	25A529	ARM, gun holder, linelazer (includes 151)	1
119a	24Y919	BRACKET, cable	1
119b*	15F216	HOLDER, gun	1
119c	17J575	FASTENER, special	1
119d*	119664	BEARING, sleeve	1
119e	17J576	SPACER, special	1
119f	119647	SCREW, cap, socket	2
119g	17H673	STUD, cable, gun	1
119h	15F214	LEVER, actuator	1
119i	17H674	ADAPTER, cable, gun	1
119j	102040	NUT, lock hex	2
119k	15F209	STUD, pull, trigger	1
119l	17J145	ARM, holder, gun	1
119m*	15F750	KNOB, holder, gun	1
120	25A488	CABLE, gun, manual (includes 126, 151)	1
121	188135	GUIDE, cable	1
122	248157	GUN, flex, basic	1
128▲	16P136	LABEL, safety, warning, iso	1
151	126111	RETAINER, circlip, external, 8mm	2
158	108471	KNOB, pronged	1
159	111145	KNOB, pronged	2
165	17J408	ARM, extension, third gun	1
211	25A487	CABLE, gun, automatic (includes 151, 212, 213)	1
225	17C043	LABEL, number "1"	1
	17C046	LABEL, number "2"	1

* Included in Gun Holder Repair Kit 287569

▲ Replacement Warning Labels may be ordered free of charge.

Gun Trigger

Ref.	Part	Description	Qty.
120	25A488	CABLE, gun, manual (includes 126, 151)	1
126	15F624	NUT, cable, gun (knurled)	2
130	25A636	BRACKET, trigger w switch	1
130a	276907	BRACKET, magnet	1
130e	17J237	SWITCH, reed	1
131	198896	BLOCK, mounting	1
132	245676	HANDLE	1
133	198895	PLATE, lever, pivot	2
134	111017	BEARING, flange	2
135	116941	SCREW, shoulder, skt hd	1
136	116969	NUT, lock	1
137	112381	SCREW, mach, pan head	1
138	117268	BRACKET, interrupter	1
139	117269	SPRING	1
140	128803	SCREW, thd forming, hex washer	1
142	117317	SCREW, plastine, pan head	2
144	17K587	LABEL, notice, adjustment	1

Parts Drawing - LineLazer V 200HS

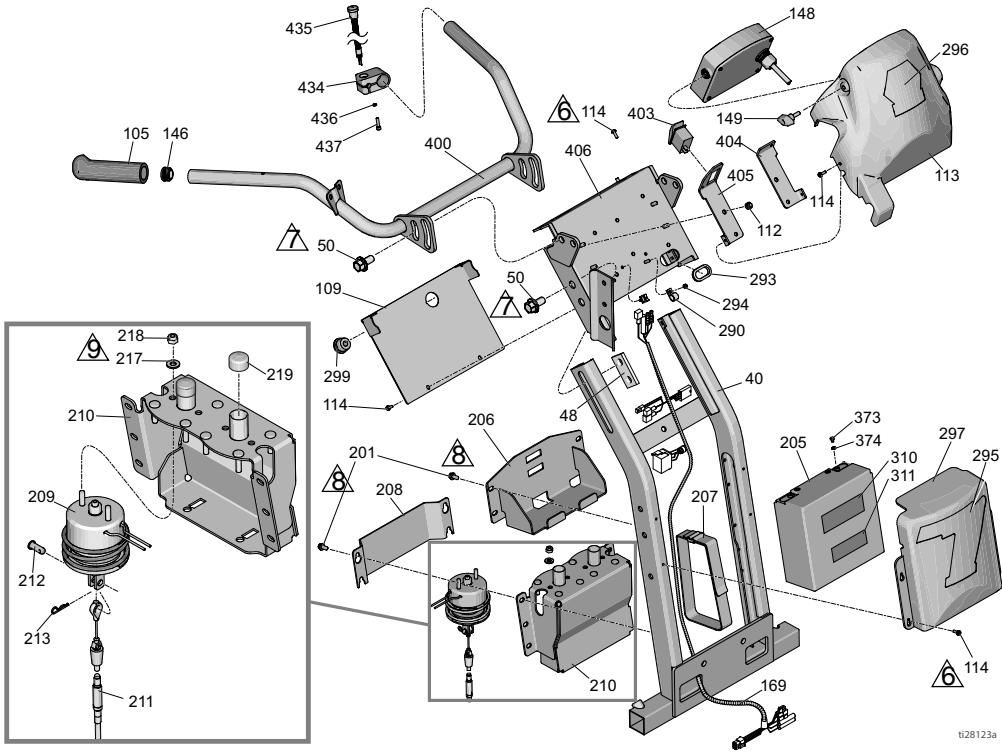

NOTICE	
<p>Do not allow the solenoid wires to make a sharp bend as shown. Doing so may lead to wire breakage. Place an approximate 0.75" radius bend in the wires exiting the solenoid.</p>	

- Torque to 35-45 ft-lbs (47.4-61.0 N·m)
- Torque to 190-210 in-lbs (21.4-23.7 N·m)
- Torque to 365-385 in-lbs (41.2-43.4 N·m)
- Torque to 25-30 in-lbs (2.8-3.3 N·m)
- Torque to 6-8 in-lbs (0.6-0.9 N·m)
- Torque to 18-22 in-lbs (2.0-2.4 N·m)
- Torque to 45-55 ft-lbs (61.0-74.5 N·m)
- Torque to 130-150 in-lbs (14.6-16.9 N·m)
- Torque to 65-75 in-lbs (7.3-8.4 N·m)

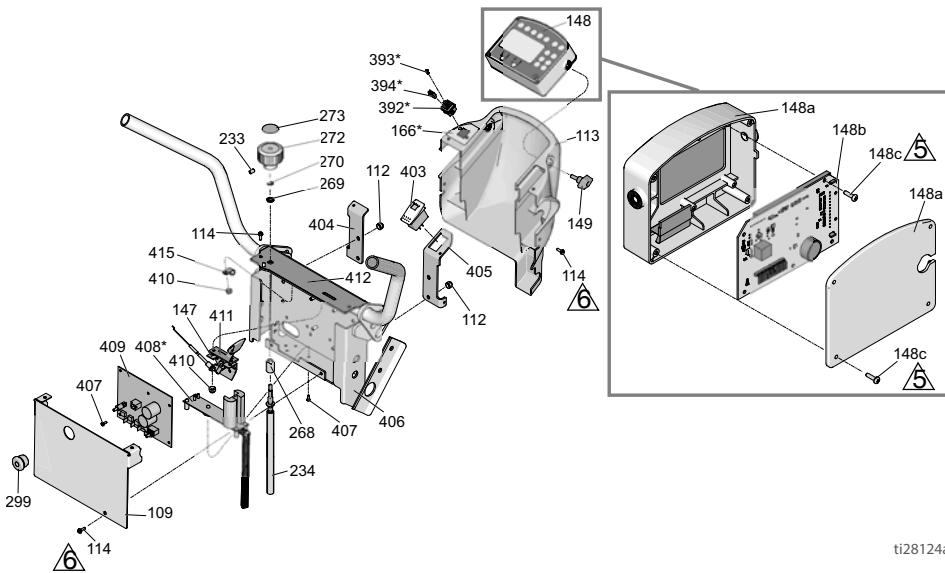

*HP Auto Series Only (408)

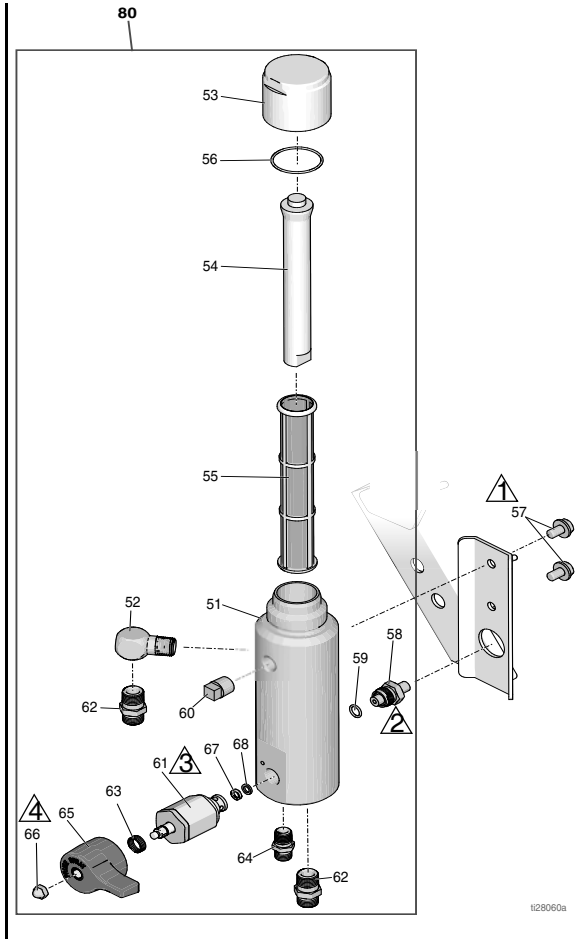

Parts List

Handle/Controls

Ref	Part	Description	Qty
40	24Y665	FRAME, handle upright, painted	1
48	17J125	BRACKET, slide	2
50	17J136	SCREW, hex, flange head	8
105	114659	GRIP, handle	2
109	17J123	PLATE, cover	1
112	102040	NUT, lock, hex	4
113	17J135	COVER, control, painted (Series A)	1
	17V517	COVER, control, painted (Series B)	1
114	128978	SCREW, mach, slot hex wash hd	12
146	120151	PLUG	2
147	24Y643	CONTROL, throttle (includes 410, 411, 415)	1
148	25A498	BOX, control assembly (includes 149) (Series A)	1
	17W550	BOX, control assembly (includes 149) (Series B)	1
148a	25A497	KIT, repair, membrane switch (includes 148c)	1
148b	25A496	KIT, repair, display board (includes 148c) (Series A)	1
	17W549	KIT, repair, display board (includes 148c) (Series B)	1
149	16W408	KNOB, t-handle, 1/4-20 thd stud	2
166	17V520	LABEL, usb	1
169	17J617	WIRE, harness	1
201	107257	SCREW, thd forming	10
205	24X370	BATTERY, 22 AH, sealed (includes 373, 374)	1
206	17H644	SHELF, battery	1
207	126949	STRAP, battery	1
208	17H650	COVER, solenoid, automatic (includes 151, 212, 213)	1
209	25A486	SOLENOID, module (includes 212, 213, 217, 218, 219)	1
210	24Y777	BRACKET, solenoid	1
211	25A487	CABLE, gun, solenoid, auto (includes 151, 212, 213)	1
212	128711	PIN, clevis, 5/16	1
213	15R598	CLIP, cotter, hairpin	1
217	110755	WASHER, plain	2
218	121114	NUT, hex, self locking	2
219	128712	CAP, dust	2
233	101962	SCREW, set, sch	2
234	25A255	SHAFT, flexible	1
268	17H698	BUSHING, pressure control, mount	1
269	119775	NUT, panel	1
270	115999	RING, retaining	1
272	16Y408	KNOB, pressure control	1
273	15A464	LABEL, control	1
290	128856	CLAMP	2
293	17H701	GROMMET	1
294	115483	NUT	2
295	17K378	LABEL	1
296	17K379	LABEL	1
297	17K377	COVER, battery, painted	1
299	17K310	PLUG, button	1

Ref	Part	Description	Qty
310	17K397	LABEL	1
311	17K396	LABEL	1
373	128131	SCREW	2
374	111307	WASHER	2
392	25M792	BOARD, assembly	1
393	17V519	SCREW, pan hd	2
394	17V518	COVER, dust, usb	2
400	24Y641	BAR, handle	1
403	128855	SWITCH, rocker	1
404	17J126	BRACKET, shroud	1
405	17J128	BRACKET, switch	1
406	24Y642	PLATE, control	1
407	106520	SCREW, thd forming	11
408*	25A495	KIT, repair, charger board (includes 407)	1
409	25A493	KIT, repair, main board, standard series (includes 407)	1
	25A494	KIT, repair, main board, HP auto series (includes 407)	1
410	111280	NUT, locking	3
411	15F776	GASKET, throttle	1
412	17J456	LABEL	1
415	119736	CLAMP	1
434*	15K162	BLOCK	1
435*	17J236	SWITCH, push button	1
436*	C19277	WASHER, lock, split, hi-collar	1
437*	C20004	SCREW, cap	1

*HP Auto Series only

Filter

Ref	Part	Description	Qty
51	17K166	MANIFOLD	1
52	196179	FITTING, elbow, street	1
53	287285	CAP, filter (includes 54, 56)	1
54	15C766	TUBE, diffusion	1
55	25A465	FILTER, fluid	1
56	117285	PACKING, o-ring	1
57	111801	SCREW, cap, hex hd	2
58	24N516	TRANSDUCER, pressure control (includes 59)	1
59	111457	O-RING	2
60	15G331	PLUG, pipe	1
61	245103	VALVE, drain, assy (includes 63, 65, 66, 67, 68)	1
62	196178	ADAPTER, nipple	1
63	114708	SPRING, compression	1
64	196181	FITTING, nipple	1
65	15G563	HANDLE, valve	1
66	116424	NUT, cap	1
67	193709	SEAT, valve	1
68	193710	SEAL, seat, valve	1
80	25A877	KIT, repair, filter manifold	1

Parts Drawing - LineLazer V 200HS

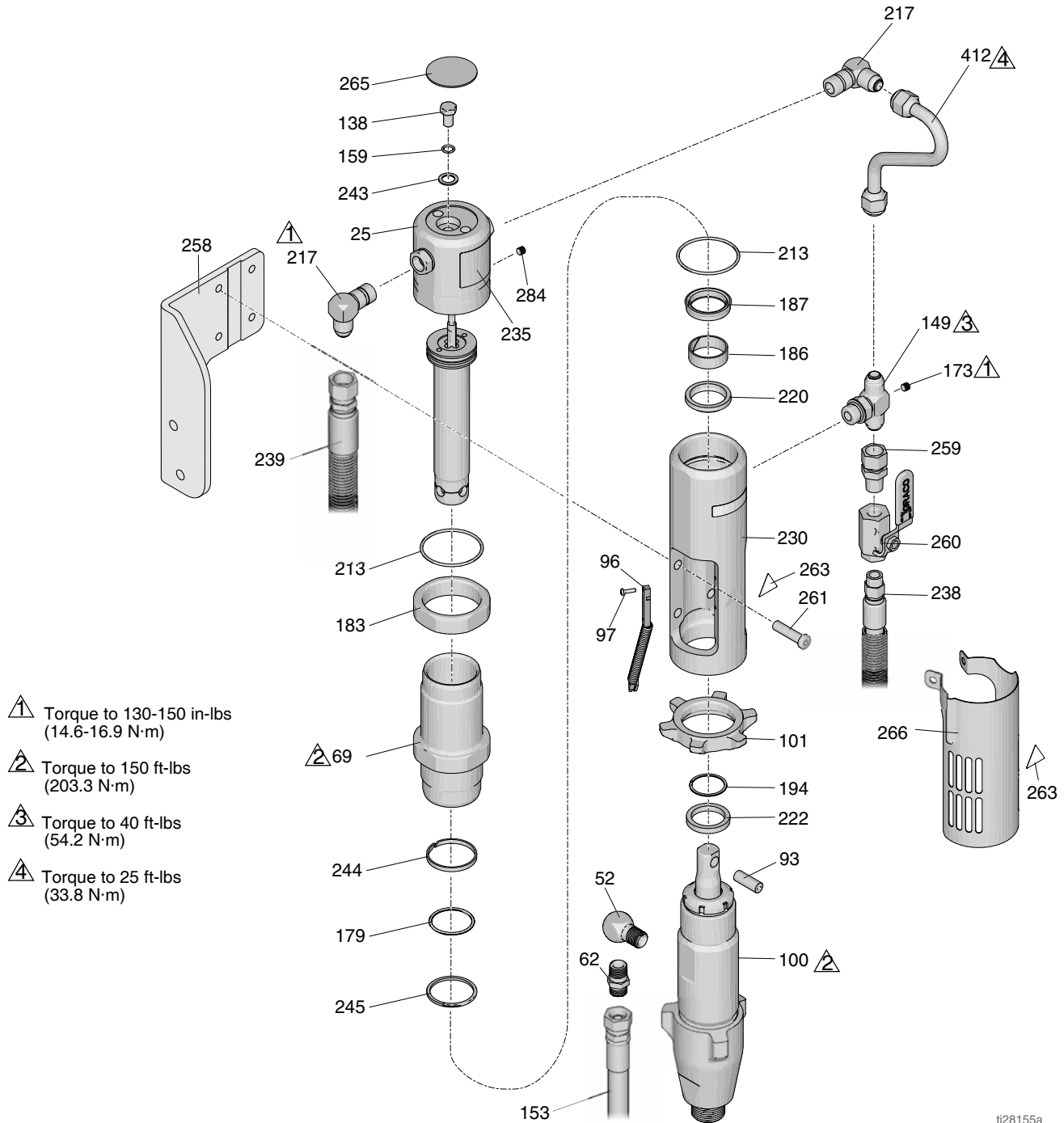

▲ Torque to 130-150 in-lbs
(14.6-16.9 N·m)

▲ Torque to 150 ft-lbs
(203.3 N·m)

▲ Torque to 40 ft-lbs
(54.2 N·m)

▲ Torque to 25 ft-lbs
(33.8 N·m)

ti28155a

Parts List

Ref.	Part	Description	Qty.	Ref.	Part	Description	Qty.
25◆	288754	KIT, repair, trip rod/piston	1	222	287186	KIT, repair, magnet	1
52	196179	FITTING, elbow, street	1	230	15A728	MANIFOLD, adapter	1
62	196178	ADAPTER, nipple	2	235◆	15B804	LABEL, graco logo	1
69◆	246176	KIT, repair, sleeve, cylinder		238	287175	HOSE, hydraulic, supply	1
93	197443	PIN, pump	1	243*◆	178179	WASHER, sealing	1
96	119720	SWITCH, reed w/ connector	1	239	287176	KIT, repair, hose	1
97	114528	SCREW, mach, phillips, pnhd	2	244*‡◆	178207	BEARING, piston	
100	277068	PUMP, displacement	1	245*‡◆	178226	SEAL, piston	1
138*◆	106276	SCREW, cap, hex head	1	258	17H681	BRACKET, mount, pump, hydraulic	1
101	193394	NUT, retaining	1	259	117328	FITTING, nipple, straight	1
149	119841	FITTING, tee, branch, str thd	1	260	117441	VALVE, ball	1
159*◆	155685	PACKING, o-ring	1	261	107210	SCREW	4
153	245226	HOSE, coupled 3/8 x 3'	1	263*▲	15H108	LABEL, warning, pinch point	2
173	100139	PLUG, pipe	1	265▲	15B063	LABEL, safety, warning, hot surface	1
179*‡◆	108014	PACKING, o-ring	1	266	24X474	COVER, assy, pump rod	1
183◆	15A726	NUT, jam	1	284*◆	100139	PLUG, pipe	
186*◆	112342	BEARING, rod	1	412	15F519	TUBE, hydraulic, supply	1
187‡◆	112561	PACKING, block	1				
194	116551	RING, retainer	1				
213*‡◆	117283	PACKING, o-ring	2				
217	117607	FITTING, elbow, std thd	2				
220*‡	117739	WIPER, rod	1				

* Included in Trip Rod/Piston/Cap Repair Kit 288754

‡ Included in Hydraulic Seal Repair Kit 246174

◆ Included in Hydraulic Motor Kit 248021

▲ Replacement Warning Labels may be ordered free of charge.

Parts Drawing - LineLazer V 200HS

 Torque to 115-135 in-lbs
(12.9-15.2 N·m)

 Torque to 190-210 in-lbs
(21.4-23.7 N·m)

 Torque to 58-62 in-lbs
(6.5-7.0N·m)

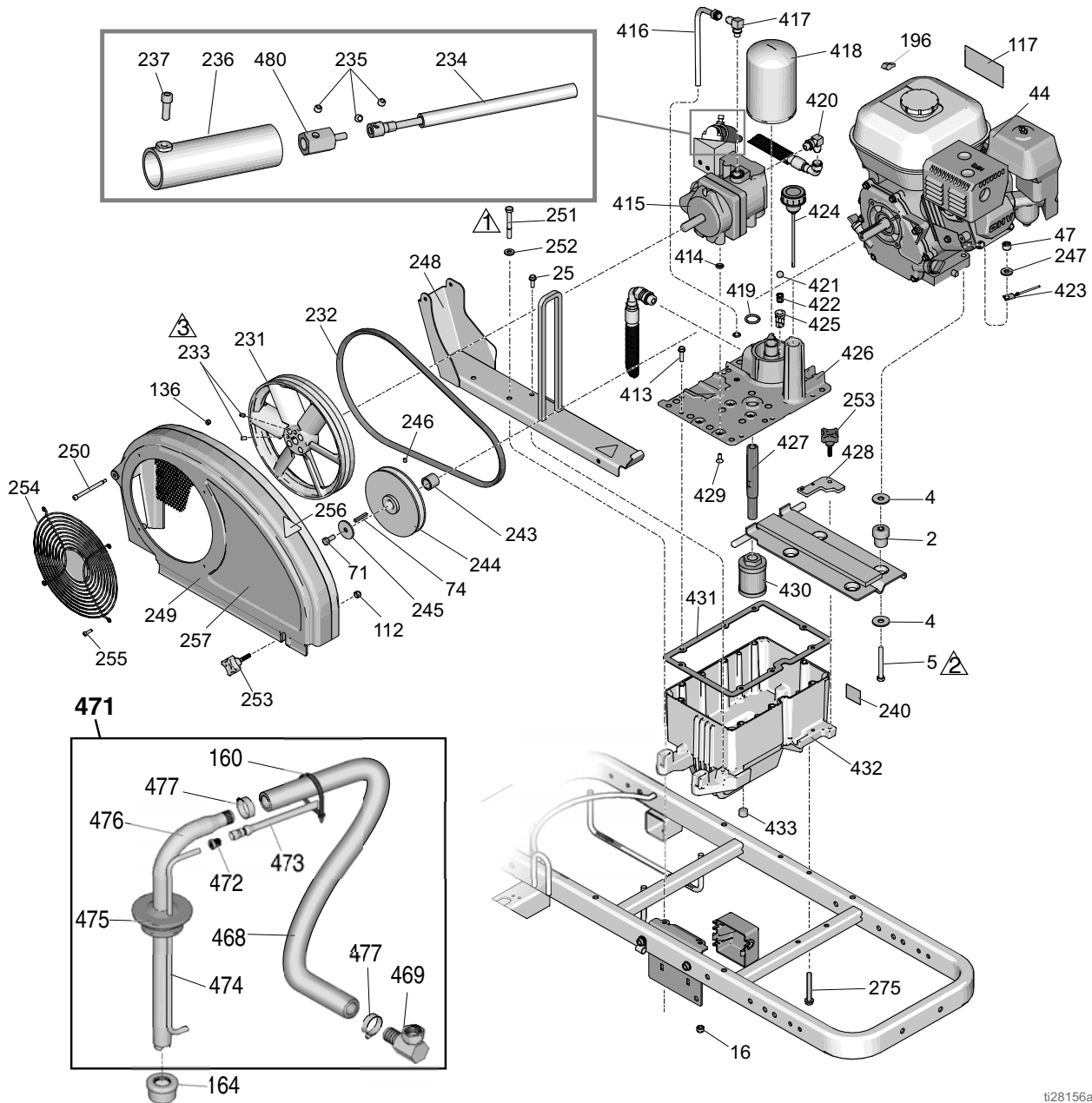

t28156a

Parts List

Ref.	Part	Description	Qty.	Ref.	Part	Description	Qty.
2	15E888	DAMPENER, motor mount	4	257	17H689	LABEL, branc, LLV 200 hs, shroud	1
4	108851	WASHER, plain	8	275	120981	SCREW, mach, hex washer hd	2
5	113664	SCREW, cap, hex hd	4	413	119426	SCREW, mach, hex washer hd	8
16	111040	NUT, lock, insert, nylock, 5/16	2	414	107188	PACKING, o-ring	4
25	260212	SCREW, hex, washer hd, thd form	2	415	287179	KIT, repair, pump (includes 235, 414, 419, 429, 480)	1
44	116080	ENGINE	1	416	246167	KIT, repair, case drain	1
47	110838	NUT, lock	4	417	110792	FITTING, elbow, male, 90°	1
71	108842	SCREW, cap, hex hd	1	418	246173	KIT, repair, oil filter	1
74	117632	KEY, square, 3/16 x 1.25	1	419	156401	PACKING, o-ring	1
112	102040	NUT, lock, hex	1	420	116829	FITTING, elbow, hydraulic	1
117▲	194126	LABEL, warning	1	421	100084	BALL, metallic	1
136	116969	NUT, lock	2	422	116967	SPRING, compression	1
160	404989	STRAP, tie	4	423	240997	CONDUCTOR, ground	1
164	181072	STRAINER, inlet	1	424	120726	CAP, breather, filler	1
196	114956	TERMINAL, wire tap, insulated	1	425	198841	RETAINER, ball, pressure bypass	1
231	16U205	PULLEY, fan	1	426	15M057	COVER, reservoir, 200HS	1
232	119433	BELT	1	427	15E587	TUBE, suction	1
233	120087	SCREW, set, 1/4 x 1/2	2	428	15E476	BRACKET, retainer, motor	1
234	25A255	SHAFT, flexible, hydraulic control	1	429	117471	SCREW, mach, hex flat head	4
235	112303	SCREW, set, socket w/ patch	3	430	116919	FILTER, screen, suction	1
236	15C958	GUARD, pressure control	1	431	120604	GASKET, reservoir	1
237	112166	SCREW, cap, sch	7	432	15J513	TANK, reservoir	1
240	15K440	LABEL, brand, GH EH cooling	1	433	101754	PLUG, pipe, 3/8 nptf	1
243	15B314	SLEEVE, motor shaft	1	468	194306	HOSE, fluid	1
244	15E758	PULLEY, 5.50 in.	1	469	198119	FITTING, elbow, barbed	1
245	112717	WASHER	1	471	24V064	HOSE, suction/drain	1
246	100002	SCREW, set, sch	1	472	196180	BUSHING	1
247	100023	WASHER, flat	4	473	248008	HOSE, coupled, 1/4" x 44"	1
248	288261	RAIL, belt guard, assy	1	474	16X071	TUBE, drain line	1
249	288734	GUARD, belt (includes 136, 250, 254, 255)	1	475	278722	GASKET, pail	1
250	119434	SCREW, shoulder, skt hd	1	476	15F149	TUBE, suction	1
251	802277	SCREW, machine	2	477	101818	CLAMP, hose	2
252	100527	WASHER, plain	2	480	16Y407	ADAPTER	1
253	15D862	NUT, hand	2				
254	117284	GRILL, fan, guard	1				
255	115477	SCREW, mach, torx pan hd	4				
256▲	16M768	LABEL, warning, iso, pinch hazard	2				

▲ Replacement Warning Labels may be ordered free of charge.

Parts Drawing - LineLazer V 200HS

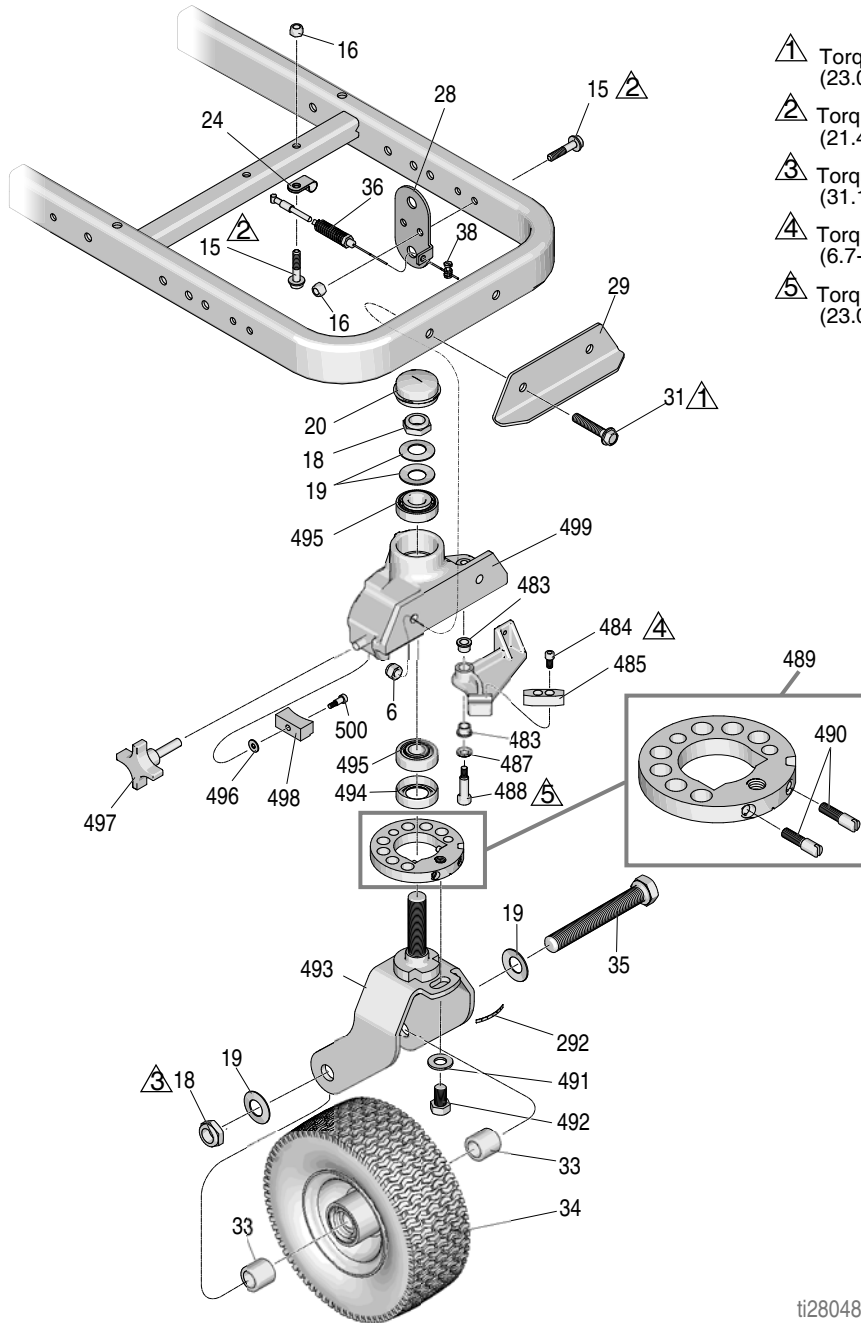

- 1 ⚠ Torque to 17-23 ft-lbs
(23.0-31.1 N·m)
- 2 ⚠ Torque to 190-210 in-lbs
(21.4-23.7 N·m)
- 3 ⚠ Torque to 23-27 ft-lbs
(31.1-36.6 N·m)
- 4 ⚠ Torque to 60-80 in-lbs
(6.7-9.0 N·m)
- 5 ⚠ Torque to 17-23 ft-lbs
(23.0-31.1 N·m)

ti28048a

Parts List

Ref	Part	Description	Qty	Ref	Part	Description	Qty
6	101566	NUT, lock	2	487*‡	15J603	SPACER, round	1
15	112960	SCREW, cap, flng hd	3	488*‡	120476	BOLT, shoulder	1
16	111040	NUT, lock, insert, nylon, 5/16	3	489*‡	17H486	DISK, adjuster, assembly	1
18*‡	112405	NUT, lock	2	490*‡	17G762	SCREW, disk adjuster	1
19*‡	112825	WASHER	4	491*‡	113962	WASHER	1
20*‡	114648	CAP, dust	1	492*	114681	SCREW, cap, hex hd	1
24	108868	CLAMP, wire	1	493*‡	17H485	FORK	1
28‡	15F910	BRACKET, cable	1	494*‡	113484	SEAL, grease	1
29	240991	BRACKET, caster, front	1	495*‡	113485	BEARING, cup/cone	2
31	114982	SCREW, cap, flng hd	2	496*‡	112776	WASHER, plain	1
33*‡	193658	SPACER, seal	2	497*‡	181818	KNOB, pronged	1
34*	114549	WHEEL, pneumatic	1	498*‡	193661	JAW	1
35*	113471	SCRE, cap, hex hd	1	499*‡	15G952	CASTER	1
36‡	241445	CABLE	1	500*‡	108483	SCREW, shoulder	1
38‡	114802	STOP, wire	1				
292*‡	17H489	LABEL, disk adjustment	1				
483*‡	114548	BEARING, bronze	2				
484*‡	110754	SCREW, cap, sch	2				
485*‡	193662	STOP, wedge	1				

* Included in Swivel Wheel Repair Kit 240719

‡ Included in Swivel Wheel Repair Kit 241105

Wiring Diagram (Standard Series)

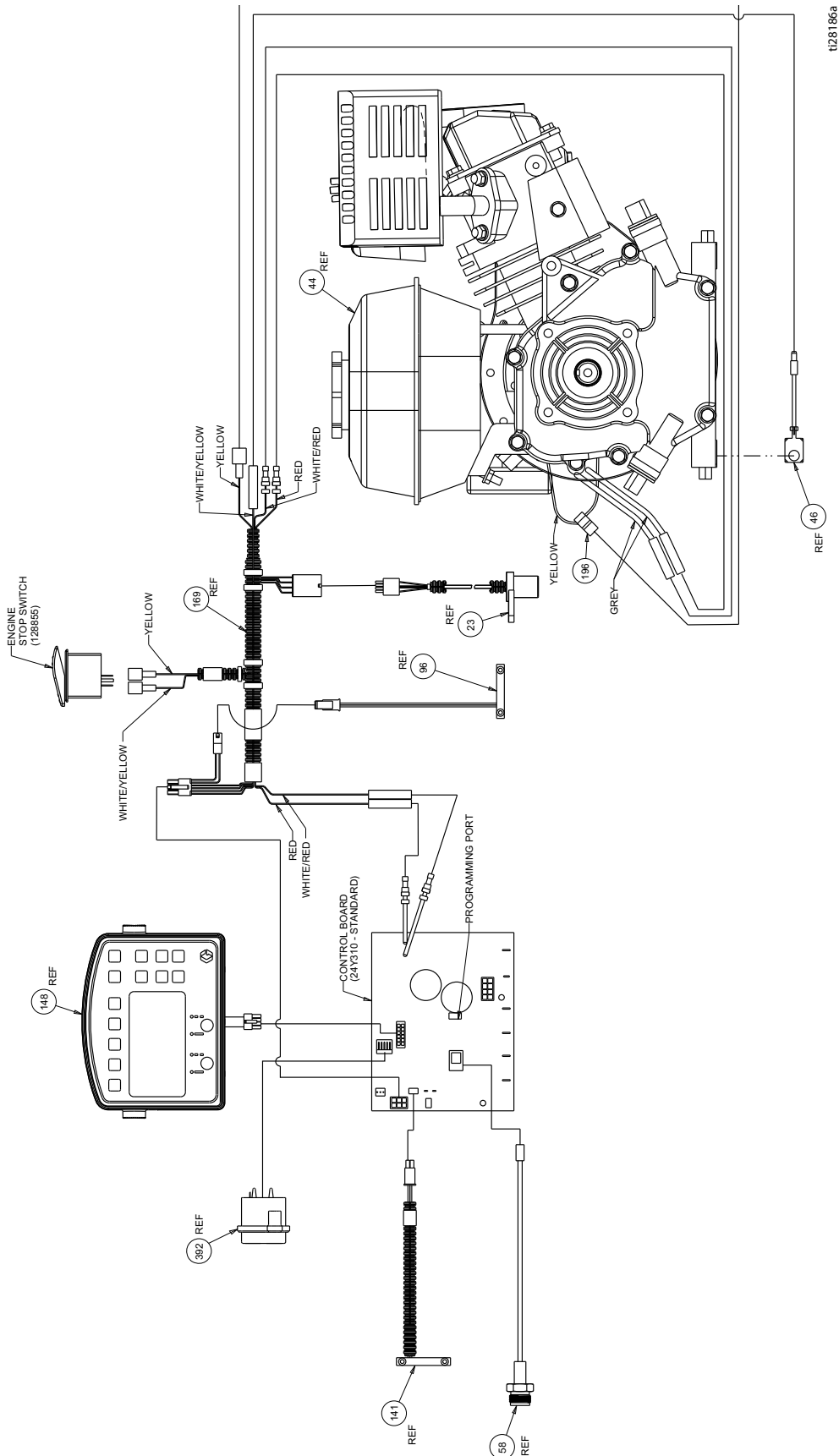

Wiring Diagram (HP Auto Series/HP Reflective Series)

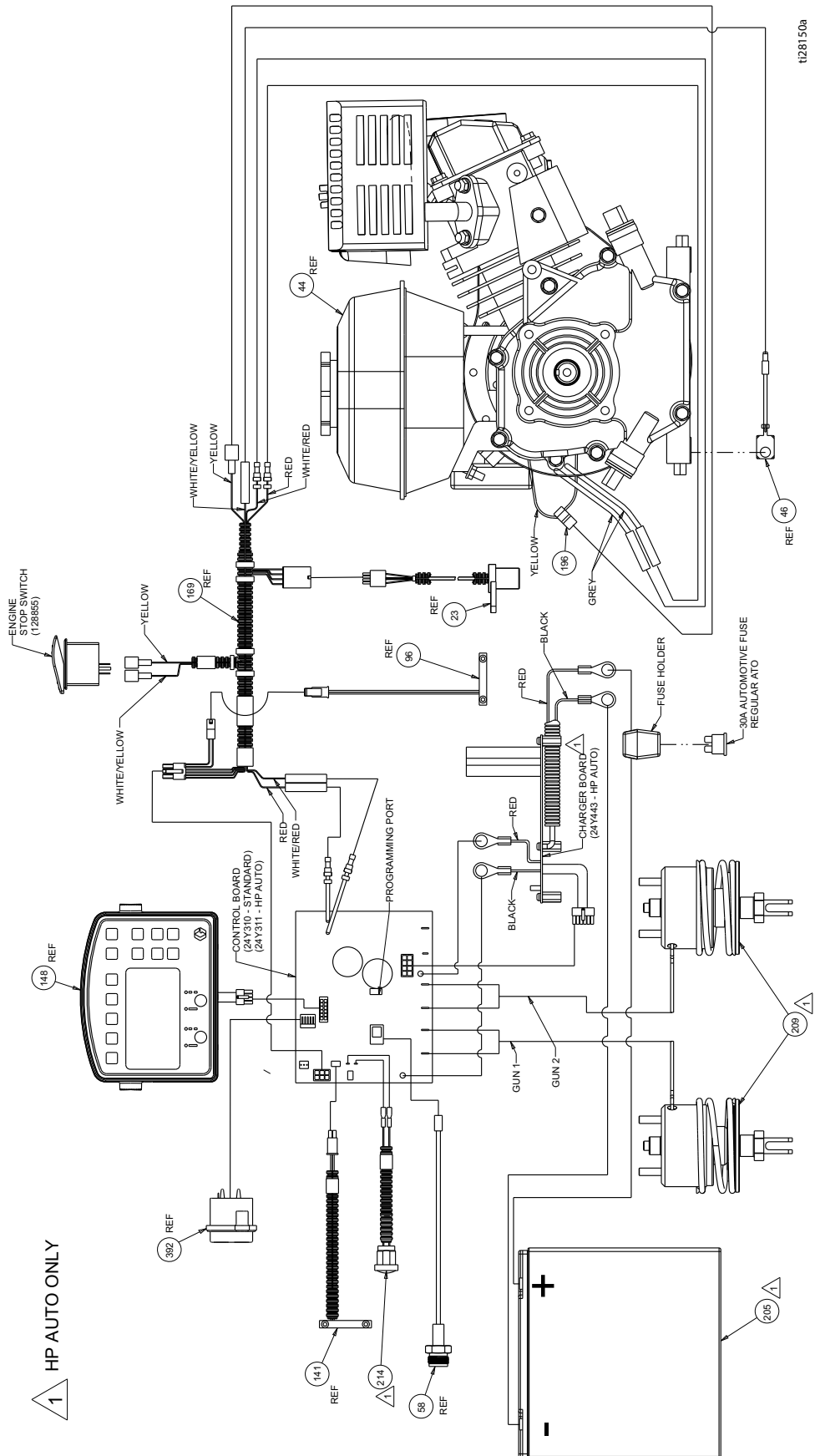

Technical Specifications

LineLazer V 200HS Standard Series (Models 17H459, 17H461)		
	U.S.	Metric
Dimensions		
Height (with handle bar down)	Unpackaged - 44.5 in. Packaged - 52.5 in.	Unpackaged - 113.03 cm Packaged - 133.35 cm
Width	Unpackaged - 34.25 in. Packaged - 37.0 in.	Unpackaged - 87.0 cm Packaged - 93.98 cm
Length (with platform down)	Unpackaged - 68.75 in. Packaged - 73.5 in.	Unpackaged - 174.63 cm Packaged - 186.69 cm
Weight (dry - no paint)	Unpackaged - 306 lbs Packaged - 373 lbs	Unpackaged - 139 kg Packaged - 169 kg
Noise (dBa)		
Sound Power per ISO 3744:	103.1	
Sound Pressure measured at 3.3 feet (1m):	86.5	
Vibration (m/s²) (8 hours daily exposure)		
Hand Arm (per ISO 5349)	1.6	
Whole Body (per ISO 2631)	0.4	
Power Rating (Horse Power)		
Power Rating (Horse Power) per SAE J1349	6.5 HP @ 3600 rpm	4.84 kW @ 3600 rpm
Maximum Delivery	2.15 gpm	8.14 lpm
Maximum Tip Size 1 gun 2 gun	.047 .034	
Inlet paint strainer	16 mesh	1190 micron
Outlet paint strainer	50 mesh	297 micron
Pump inlet size	1 in. NSPM (m)	
Pump outlet size	3/8 NPT (f)	
Maximum working pressure	3300 psi	228 bar, 22.8 MPa
Maximum fluid working pressure	3300 psi	228 bar, 22.8 MPa
Maximum free-flow delivery	2.15 gpm	8.14 lpm
Cycles per gallon/liter	62 cpg	16.4 cpl
Hydraulic reservoir capacity	1.25 gallons	4.73 liters
Hydraulic pressure	1825 psi	124 bar
Electrical Capacity	84 W @ 3800 rpm	
Starting Battery	12V, 22Ah, Sealed lead acid, Deep cycle	

Wetted Parts: PTFE, Nylon, polyurethane, V-Max, UHMWPE, fluoroelastomer, acetal, leather, tungsten carbide, stainless steel, chrome plating, nickel-plated carbon steel, ceramic

LineLazer V 200HS HP Auto Series (Models 17K582, 17H462, 17K637, 17H463, 17K583, 17H464)		
	U.S.	Metric
Dimensions		
Height (with handle bar down)	Unpackaged - 44.5 in. Packaged - 52.5 in.	Unpackaged - 113.03 cm Packaged - 133.35 cm
Width	Unpackaged - 34.25 in. Packaged - 37.0 in.	Unpackaged - 87.0 cm Packaged - 93.98 cm
Length (with platform down)	Unpackaged - 68.75 in. Packaged - 73.5 in.	Unpackaged - 174.63 cm Packaged - 186.69 cm
Weight (dry - no paint)	Unpackaged - 322 lbs Packaged - 389 lbs	Unpackaged - 146 kg Packaged - 176 kg
Noise (dBa)		
Sound Power per ISO 3744:	103.1	
Sound Pressure measured at 3.3 feet (1m):	86.5	
Vibration (m/s²) (8 hours daily exposure)		
Hand Arm (per ISO 5349)	1.6	
Whole Body (per ISO 2631)	0.4	
Power Rating (Horse Power)		
Power Rating (Horse Power) per SAE J1349	6.5 HP @ 3600 rpm	4.84 kW @ 3600 rpm
Maximum Delivery	2.15 gpm	8.14 lpm
Maximum Tip Size		
1 gun	.047	
2 gun	.034	
Inlet paint strainer	16 mesh	1190 micron
Outlet paint strainer	50 mesh	297 micron
Pump inlet size	1 in. NSPM (m)	
Pump outlet size	3/8 NPT (f)	
Maximum working pressure	3300 psi	228 bar, 22.8 MPa
Maximum fluid working pressure	3300 psi	228 bar, 22.8 MPa
Maximum free-flow delivery	2.15 gpm	8.14 lpm
Cycles per gallon/liter	62 cpg	16.4 cpl
Hydraulic reservoir capacity	1.25 gallons	4.73 liters
Hydraulic pressure	1825 psi	124 bar
Electrical Capacity	84 W@ 3600 rpm	
Starting Battery	12V, 22Ah, Sealed lead acid, Deep cycle	

Wetted Parts: PTFE, Nylon, polyurethane, V-Max, UHMWPE, fluoroelastomer, acetal, leather, tungsten carbide, stainless steel, chrome plating, nickel-plated carbon steel, ceramic

LineLazer V 200HS HP Reflective Series (Models 17H460, 17J964, 17K585, 17H465)		
	U.S.	Metric
Dimensions		
Height (with handle bar down)	Unpackaged - 44.5 in. Packaged - 52.5 in.	Unpackaged - 113.03 cm Packaged - 133.35 cm
Width	Unpackaged - 34.25 in. Packaged - 37.0 in.	Unpackaged - 87.0 cm Packaged - 93.98 cm
Length (with platform down)	Unpackaged - 68.75 in. Packaged - 73.5 in.	Unpackaged - 174.63 cm Packaged - 186.69 cm
Weight (dry - no paint)	Unpackaged - 417 lbs Packaged - 484 lbs	Unpackaged - 189 kg Packaged - 219kg
Noise (dBa)		
Sound Power per ISO 3744:	103.1	
Sound Pressure measured at 3.3 feet (1m):	86.5	
Vibration (m/s²) (8 hours daily exposure)		
Hand Arm (per ISO 5349)	1.6	
Whole Body (per ISO 2631)	0.4	
Power Rating (Horse Power)		
Power Rating (Horse Power) per SAE J1349	6.5 HP @ 3600 rpm	4.84 kW @ 3600 rpm
Maximum Delivery	2.15 gpm	8.14 lpm
Maximum Tip Size 1 gun 2 gun	.047 .034	
Inlet paint strainer	16 mesh	1190 micron
Outlet paint strainer	50 mesh	297 micron
Pump inlet size	1 in. NSPM (m)	
Pump outlet size	3/8 NPT (f)	
Maximum working pressure	3300 psi	228 bar, 22.8 MPa
Maximum fluid working pressure	3300 psi	228 bar, 22.8 MPa
Maximum free-flow delivery	2.15 gpm	8.14 lpm
Cycles per gallon/liter	62 cpg	16.4 cpl
Hydraulic reservoir capacity	1.25 gallons	4.73 liters
Hydraulic pressure	1825 psi	124 bar
Electrical Capacity	84 W @ 3600 rpm	
Starting Battery	12V, 22Ah, Sealed lead acid, Deep cycle	

Wetted Parts: PTFE, Nylon, polyurethane, V-Max, UHMWPE, fluoroelastomer, acetal, leather, tungsten carbide, stainless steel, chrome plating, nickel-plated carbon steel, ceramic

Graco Standard Warranty

Graco warrants all equipment referenced in this document which is manufactured by Graco and bearing its name to be free from defects in material and workmanship on the date of sale to the original purchaser for use. With the exception of any special, extended, or limited warranty published by Graco, Graco will, for a period of twelve months from the date of sale, repair or replace any part of the equipment determined by Graco to be defective. This warranty applies only when the equipment is installed, operated and maintained in accordance with Graco's written recommendations.

This warranty does not cover, and Graco shall not be liable for general wear and tear, or any malfunction, damage or wear caused by faulty installation, misapplication, abrasion, corrosion, inadequate or improper maintenance, negligence, accident, tampering, or substitution of non-Graco component parts. Nor shall Graco be liable for malfunction, damage or wear caused by the incompatibility of Graco equipment with structures, accessories, equipment or materials not supplied by Graco, or the improper design, manufacture, installation, operation or maintenance of structures, accessories, equipment or materials not supplied by Graco.

This warranty is conditioned upon the prepaid return of the equipment claimed to be defective to an authorized Graco distributor for verification of the claimed defect. If the claimed defect is verified, Graco will repair or replace free of charge any defective parts. The equipment will be returned to the original purchaser transportation prepaid. If inspection of the equipment does not disclose any defect in material or workmanship, repairs will be made at a reasonable charge, which charges may include the costs of parts, labor, and transportation.

THIS WARRANTY IS EXCLUSIVE, AND IS IN LIEU OF ANY OTHER WARRANTIES, EXPRESS OR IMPLIED, INCLUDING BUT NOT LIMITED TO WARRANTY OF MERCHANTABILITY OR WARRANTY OF FITNESS FOR A PARTICULAR PURPOSE.

Graco's sole obligation and buyer's sole remedy for any breach of warranty shall be as set forth above. The buyer agrees that no other remedy (including, but not limited to, incidental or consequential damages for lost profits, lost sales, injury to person or property, or any other incidental or consequential loss) shall be available. Any action for breach of warranty must be brought within two (2) years of the date of sale.

GRACO MAKES NO WARRANTY, AND DISCLAIMS ALL IMPLIED WARRANTIES OF MERCHANTABILITY AND FITNESS FOR A PARTICULAR PURPOSE, IN CONNECTION WITH ACCESSORIES, EQUIPMENT, MATERIALS OR COMPONENTS SOLD BUT NOT MANUFACTURED BY GRACO. These items sold, but not manufactured by Graco (such as electric motors, switches, hose, etc.), are subject to the warranty, if any, of their manufacturer. Graco will provide purchaser with reasonable assistance in making any claim for breach of these warranties.

In no event will Graco be liable for indirect, incidental, special or consequential damages resulting from Graco supplying equipment hereunder, or the furnishing, performance, or use of any products or other goods sold hereto, whether due to a breach of contract, breach of warranty, the negligence of Graco, or otherwise.

FOR GRACO CANADA CUSTOMERS

The Parties acknowledge that they have required that the present document, as well as all documents, notices and legal proceedings entered into, given or instituted pursuant hereto or relating directly or indirectly hereto, be drawn up in English. Les parties reconnaissent avoir convenu que la rédaction du présente document sera en Anglais, ainsi que tous documents, avis et procédures judiciaires exécutés, donnés ou intentés, à la suite de ou en rapport, directement ou indirectement, avec les procédures concernées.

POUR LES CLIENTS DE GRACO PARLANT FRANCAIS

Les parties reconnaissent avoir convenu que la rédaction du présent document ainsi que de tous les documents, avis et procédures judiciaires exécutés, donnés ou intentés à la suite de ou en rapport, directement ou indirectement, avec les procédures concernées, sera en anglais.

ADDITIONAL WARRANTY COVERAGE

Graco does provide extended warranty and wear warranty for products described in the "Graco Contractor Equipment Warranty Program".

Graco Information

For the latest information about Graco products, visit www.graco.com.

For patent information, see www.graco.com/patents.

TO PLACE AN ORDER, contact your Graco distributor or call 1-800-690-2894 to identify the nearest distributor.

All written and visual data contained in this document reflects the latest product information available at the time of publication. Graco reserves the right to make changes at any time without notice.

Original instructions. This manual contains English. MM 3A3390

Graco Headquarters: Minneapolis

International Offices: Belgium, China, Japan, Korea

GRACO INC. AND SUBSIDIARIES • P.O. BOX 1441 • MINNEAPOLIS MN 55440-1441 • USA
Copyright 2016, Graco Inc. All Graco manufacturing locations are registered to ISO 9001.

www.graco.com

Revision C, May 2018