

# Manzel® Lube-Line Alert

## A Positive Safeguard – Indicates lubricant flow or no flow

### DESCRIPTION

The Manzel Lube-Line Alert is an easily installed device providing positive protection for compressors, pumps, engines and equipment employing any make or type of force feed lubrication system. Installed as close to each point of lubrication as possible, the unit acts as a sentinel to indicate flow or no-flow at any point in the system ahead of the Lube-Line Alert inlet.

**One Lube-Line Alert per Pumping Unit** will warn of flow stoppage for any reason including low reservoir lubricant level; shaft rotation stoppage; broken lubricant lines; dirt under pump valves and worn plungers.

**A single Lube-Line Alert per Lubricator** will warn of low reservoir lubricant level or shaft rotation stoppage.

For complete protection, there should be as many Lube-Line Alert units in your installations as there are points of lubrication.

The Manzel Lube-Line Alert provides low-cost, dependable protection for costly machinery.



### FEATURES

**Indicates Flow or No-Flow** at any point in the system ahead of the Lube-Line Alert inlet. Not affected by discharge pressure.

**Operates under continuous or intermittent low-flow rates.**

**Universal use** - operates in any air free force feed lubrication system - any make lubricator.

**Sensitive to a wide range of flow** - from .006 cubic inches to 190 cubic inches per minute.

**Many type lubricants and viscosities** - mineral or synthetic.

**Time delay adjustment** - to compensate for viscosity and/or flow rate. Quick and easy to adjust.

**Pressures** - for operation up to 10,000 psi.

**Explosion-proof** - UL and CSA Listed for Class I Groups C & D and Class II Groups E, F & G. Division 1 & 2 when installed as per NEC 501

**For connection to any electrical warning system** - lights, sound devices, machinery shut-off relays,, telephones, etc.

**A low-level and shaft rotation indicator** - equip one pumping unit per reservoir with Lube-Line Alert.

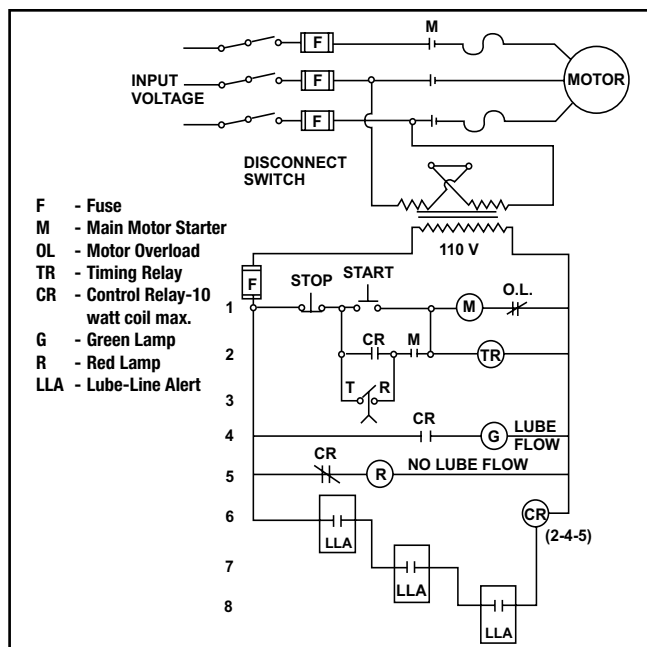

Typical wiring diagram for fail safe operation using Lube-Line Alerts assembled in N.O. normally open position. Alerts installed in a 110V control circuit side of motor starter to provided positive system protection through automatic system shut down.

### SPECIFICATIONS

<b>UL &amp; CSA Electrical Ratings</b>	<ul style="list-style-type: none"> <li>• Single pole, single</li> <li>• Throw magnetically operated switch</li> <li>• 115 VAC, 60Hz, 10 watt</li> <li>• 28 VDC, 0.5 amp Resistive</li> <li>• 28 VDC, 0.5 amp Inductive</li> </ul>
<b>Max Switch Rating</b>	350 VAC/VDC, 50 watt, 2 amp
<b>Max Operating Pressure</b>	10,000 psi
<b>Min Pressure Drop Access Alert</b>	150 psi
<b>Flow Rate</b>	<ul style="list-style-type: none"> <li>• 0.006 cu.in. to 190 cu.in. per minute @ 100 SUS</li> <li>• 0.006 cu.in. to 75 cu.in. per minute @ 2000 SUS</li> </ul>
<b>Fluid Viscosity</b>	100 to 9000 SUS
<b>Weight</b>	0.6 lbs

## OPERATION

The Manzel Lube-Line Alert is composed of a separate hydraulic body and a switch body bolted together. The hydraulic body consists of a plunger, a magnet, a spring, and an adjustable plug. The switch body consists of a hermetically sealed magnetically-actuated switch set in a potting compound. The switch body can be mounted in one of two alternate positions: one for (N.O.) normally open contacts (during no flow), the other for (N.C.) normally closed contacts (during no flow) to accommodate various alarm or shut down circuits.

Lubricant flowing through the Alert moves the plunger and magnet until the plunger has opened the cross port in the bushing. This movement of the magnet opens the contacts for the (N.C.) normally closed switch position and closes the contacts on the (N.O.) normally open switch position, thus breaking or making the electrical circuit. The lubricant then moves through the cross port, around the magnet, through the hole in the plug and on to the point of lubrication. This path is shown in grey.

When flow stops, the spring returns the magnet and plunger toward their original position. When this movement is sufficient, the magnet closes the contacts for the (N.C.) normally closed switch position or opens the contacts for the (N.O.) normally open switch position, making or breaking the alarm or shutdown circuit.

There is a built-in external time delay to adjust for various flow rates and/or viscosities, which can be easily varied by sliding the switch body "O" mark in relation to the N.C. or N.O. mark on the hydraulic body. With the N.C. or N.O. mark opposite the "O" mark, the longest time delay—from flow stoppage to indication—will be obtained. An internal screw adjustment provides an additional time delay adjustment range. This can be varied by removing the Alert outlet connection and turning the slotted screw clockwise, to decrease the delay time and counter clockwise, to increase the delay time. These adjustments should be made in 1/4 turn increments and with the N.C. or N.O. mark opposite the "O" mark.

A light spring is included (loose) with the Lube-Line Alert, Part No. 563030 (456-060-009) only. This spring is to be used in low flow applications where the unit fails to actuate.

## INSTALLATION

Cut the line as close to the point of lubrication as practical. Install the Alert with proper flow direction as shown on the nameplate. Straight or elbow fittings are available in most tubing or pipe thread sizes for the 7/16-20 NP straight thread "O" ring Alert ports.

The electrical switch housing should be set at the proper switch position—N.O. opposite "O" for normally open circuitry (during no flow) or N.C. opposite "O" for normally closed circuitry (during no flow). Lead wires from the switch are ready for connection through the 1/2" conduit connections to a suitable alarm circuit.

Fail safe circuitry can only be provided by using the N.O. (normally open) switch position. Multiple Alerts must be wired in series or through separate circuits.

For the N.C. (normally closed) switch position multiple Alerts should be wired in parallel or through separate circuits.

The loose cover must be assembled over the exposed machined face of the Alert hydraulic body to meet Underwriters' Laboratory listing. To reduce the risk of ignition of hazardous atmospheres, conduit runs must have a sealing fitting connected within 18 inches of the enclosure.

Installation at point of lubrication provides complete protection, including detection of broken lines up stream of Alert.

## ORDERING INFORMATION

Description	Part No.	Old Part No.
<b>Lube-Line Alert</b>		
N.C. Configuration w/Check Valves for 1/4 in O.D. Tube, Standard Spring (installed), w/ Light Spring (loose)*	563030	456-060-009
N.O. Configuration w/Check Valves for 1/4 in O.D. Tube, Standard Spring (installed), w/ Light Spring (loose)*	563033	456-060-181
N.O. Configuration w/Check Valves & Fittings for 1/8 in NPTF Connections, Standard Spring (installed)	563032	456-060-109
<b>Accessory Parts</b>		
<b>Inlet Check Valves</b>		
w/ 1/4 in O.D. Tube Inlet (supplied w/1 & 2)	563042	463-001-211
w/ 7/16-20 Straight Female Thread Outlet (supplied w/3)	563041	463-001-201
<b>Outlet Check Valves</b>		
w/ 1/4 in O.D. Tube Inlet (supplied w/1 & 2)	563044	463-001-251
w/ 7/16-20 Straight Female Thread Outlet (supplied w/3)	563043	463-001-221
<b>Fittings (w/Check Valves 4 &amp; 5), 7/16-20 Straight Male Thread x 1/8 in NPTF (2 supplied w/3)</b>	556624	435-050-040
<b>Springs</b>		
Standard Springs (installed at factory in 1 & 3)	556944	458-005-440
Light Spring for Low Flow Applicator (supplied loose w/1, installed in 2)*	556939	458-005-220
<b>Repair Parts</b>		
Switch Assembly	556812	456-060-049
Plunger & Bushing Assembly	563031	456-060-029

\*When using the Light Spring 556939 (458-005-220), fluid viscosity should not exceed 350 SUS

- 1) 563030 (456-060-009)
- 2) 563033 (456-060-181)
- 3) 563032 (456-060-109)
- 4) 563041 (463-001-201)
- 5) 563043 (463-001-221)

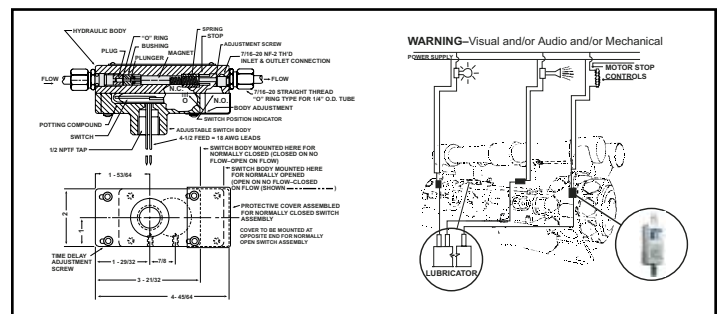

All written and visual data contained in this document are based on the latest product information available at the time of publication. Graco reserves the right to make changes at any time without notice.

## Contact us today!

To receive product information or talk with a Graco representative, call 800-533-9655 or visit us online at [www.graco.com](http://www.graco.com).

