

## Dosing Pumps

332339J  
EN

To pressurize and proportion fluid in a ProMix® PD2K Electronic Positive Displacement Proportioning System.  
For professional use only.



### Important Safety Instructions

Read all warnings and instructions in this manual and in your PD2K proportioner manual. **Save these instructions.**

*See page 2 for model part numbers and information.*

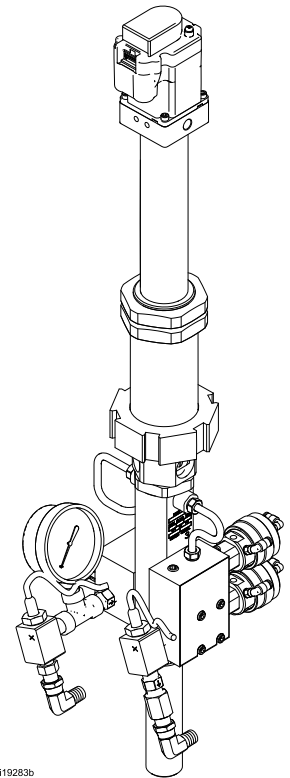

019283b

# Contents

Models.....	2	Driver Repair .....	12
Warnings .....	3	Lower Repair .....	14
Important Acid Catalyst Information .....	5	Reconnect the Lower to the Driver .....	18
Acid Catalyst Conditions.....	5	Parts.....	20
Moisture Sensitivity of Acid Catalysts .....	5	Pump Assembly.....	20
Setup.....	7	Pump Assembly (Isolated).....	22
Pump Components .....	7	Lower Pump Assembly.....	23
Air Connections .....	8	Pump Driver Assembly.....	26
Fluid Connections .....	10	Repair Kits, Related Manuals, and	
Electrical Connection.....	10	Accessories .....	27
Repair.....	11	Dimensions .....	28
Preventive Maintenance Schedule .....	11	Technical Data .....	29
Disconnect the Lower from the Driver.....	11	Graco Standard Warranty.....	30

# Models

Pump Part No.	Series	Description (see NOTE below)	Maximum Fluid Working Pressure, psi (MPa, bar)
24T788	A	35cc low pressure pump	300 (2.1, 21)
24T789	A	35cc high pressure pump	1500 (10.5, 105)
24T790	A	70cc low pressure pump	300 (2.1, 21)
24T791	A	70cc high pressure pump	1500 (10.5, 105)
24T818	A	35cc low pressure pump (acid catalyst)	300 (2.1, 21)
24T819	A	35cc high pressure pump (acid catalyst)	1500 (10.5, 105)
24W273	A	35cc low pressure pump (isolated)▶	300 (2.1, 21)
24W303	A	35cc high pressure pump (isolated)▶	1500 (10.5, 105)
24W274	A	70cc low pressure pump (isolated)▶	300 (2.1, 21)
24W304	A	70cc high pressure pump (isolated)▶	1500 (10.5, 105)

▶ The fluid section of these pumps is approved for placement in the hazardous area.

**NOTE:** Lower pumps marked with a **3** on the bottom right of the identification label are 35cc displacement pumps. Lower pumps marked with a **7** on the bottom right of the identification label are 70cc displacement pumps.

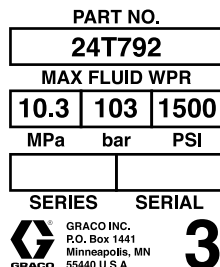











Figure 1 35cc Pump Identification Label









Figure 2 70cc Pump Identification Label

# Warnings

The following warnings are for the setup, use, grounding, maintenance and repair of this equipment. The exclamation point symbol alerts you to a general warning and the hazard symbol refers to procedure-specific risks. When these symbols appear in the body of this manual or on warning labels, refer back to these Warnings. Product-specific hazard symbols and warnings not covered in this section may appear throughout the body of this manual where applicable.







 <h2 style="margin: 0;">WARNING</h2>	
   	<p><b>FIRE AND EXPLOSION HAZARD</b></p> <p>Flammable fumes, such as solvent and paint fumes, in <b>work area</b> can ignite or explode. To help prevent fire and explosion:</p> <ul style="list-style-type: none"> <li>• Use equipment only in well ventilated area.</li> <li>• Eliminate all ignition sources; such as pilot lights, cigarettes, portable electric lamps, and plastic drop cloths (potential static arc).</li> <li>• Keep work area free of debris, including solvent, rags and gasoline.</li> <li>• Do not plug or unplug power cords, or turn power or light switches on or off when flammable fumes are present.</li> <li>• Ground all equipment in the work area. See <b>Grounding</b> instructions.</li> <li>• Use only grounded hoses.</li> <li>• Hold gun firmly to side of grounded pail when triggering into pail. Do not use pail liners unless they are antistatic or conductive.</li> <li>• <b>Stop operation immediately</b> if static sparking occurs or you feel a shock, Do not use equipment until you identify and correct the problem.</li> <li>• Keep a working fire extinguisher in the work area.</li> </ul>
  	<p><b>SKIN INJECTION HAZARD</b></p> <p>High-pressure fluid from gun, hose leaks, or ruptured components will pierce skin. This may look like just a cut, but it is a serious injury that can result in amputation. <b>Get immediate surgical treatment.</b></p> <ul style="list-style-type: none"> <li>• Do not spray without tip guard and trigger guard installed.</li> <li>• Engage trigger lock when not spraying.</li> <li>• Do not point gun at anyone or at any part of the body.</li> <li>• Do not put your hand over the spray tip.</li> <li>• Do not stop or deflect leaks with your hand, body, glove, or rag.</li> <li>• Follow the <b>Pressure Relief Procedure</b> when you stop spraying/dispersing and before cleaning, checking, or servicing equipment.</li> <li>• Tighten all fluid connections before operating the equipment.</li> <li>• Check hoses, tubes, and couplings daily. Replace worn or damaged parts immediately.</li> </ul>
 	<p><b>MOVING PARTS HAZARD</b></p> <p>Moving parts can pinch, cut or amputate fingers and other body parts.</p> <ul style="list-style-type: none"> <li>• Keep clear of moving parts.</li> <li>• Do not operate equipment with protective guards or covers removed.</li> <li>• Pressurized equipment can start without warning. Before checking, moving, or servicing equipment, follow the <b>Pressure Relief Procedure</b> and disconnect all power sources.</li> </ul>

 <h1 style="margin: 0;">WARNING</h1>	
 	<p><b>TOXIC FLUID OR FUMES</b>                      Toxic fluids or fumes can cause serious injury or death if splashed in the eyes or on skin, inhaled, or swallowed.</p> <ul style="list-style-type: none"> <li>• Read MSDSs to know the specific hazards of the fluids you are using.</li> <li>• Store hazardous fluid in approved containers, and dispose of it according to applicable guidelines.</li> <li>• Always wear chemically impermeable gloves when spraying, dispensing, or cleaning equipment.</li> </ul>
	<p><b>PERSONAL PROTECTIVE EQUIPMENT</b>                      Wear appropriate protective equipment when in the work area to help prevent serious injury, including eye injury, hearing loss, inhalation of toxic fumes, and burns. This protective equipment includes but is not limited to:</p> <ul style="list-style-type: none"> <li>• Protective eyewear, and hearing protection.</li> <li>• Respirators, protective clothing, and gloves as recommended by the fluid and solvent manufacturer.</li> </ul>
 	<p><b>EQUIPMENT MISUSE HAZARD</b>                      Misuse can cause death or serious injury.</p> <ul style="list-style-type: none"> <li>• Do not operate the unit when fatigued or under the influence of drugs or alcohol.</li> <li>• Do not exceed the maximum working pressure or temperature rating of the lowest rated system component. See <b>Technical Data</b> in all equipment manuals.</li> <li>• Use fluids and solvents that are compatible with equipment wetted parts. See <b>Technical Data</b> in all equipment manuals. Read fluid and solvent manufacturer's warnings. For complete information about your material, request MSDS from distributor or retailer.</li> <li>• Do not leave the work area while equipment is energized or under pressure.</li> <li>• Turn off all equipment and follow the <b>Pressure Relief Procedure</b> when equipment is not in use.</li> <li>• Check equipment daily. Repair or replace worn or damaged parts immediately with genuine manufacturer's replacement parts only.</li> <li>• Do not alter or modify equipment. Alterations or modifications may void agency approvals and create safety hazards.</li> <li>• Make sure all equipment is rated and approved for the environment in which you are using it.</li> <li>• Use equipment only for its intended purpose. Call your distributor for information.</li> <li>• Route hoses and cables away from traffic areas, sharp edges, moving parts, and hot surfaces.</li> <li>• Do not kink or over bend hoses or use hoses to pull equipment.</li> <li>• Keep children and animals away from work area.</li> <li>• Comply with all applicable safety regulations.</li> </ul>

# Important Acid Catalyst Information

The PD2K MC3000 and MC4000 Proportioner is designed for acid catalysts (“acid”) currently used in two-component, wood-finishing materials. Current acids in use (with pH levels as low as 1) are more corrosive than earlier acids. More corrosion-resistant wetted materials of construction are required, and must be used without substitution, to withstand the increased corrosive properties of these acids.

## Acid Catalyst Conditions

									
-----------------------------------------------------------------------------------	-----------------------------------------------------------------------------------	-----------------------------------------------------------------------------------	-----------------------------------------------------------------------------------	-----------------------------------------------------------------------------------	-----------------------------------------------------------------------------------	------------------------------------------------------------------------------------	--	--	--

Acid is flammable, and spraying or dispensing acid creates potentially harmful mists, vapors, and atomized particulates. To help prevent fire and explosion and serious injury:

- Read and understand the acid manufacturer’s warnings and Safety Data Sheet (SDS) to know specific hazards and precautions related to the acid.
- Use only genuine, manufacturer’s recommended acid-compatible parts in the catalyst system (hoses, fittings, etc). A reaction may occur between any substituted parts and the acid.
- To prevent inhalation of acid mists, vapors, and atomized particulates, everyone in the work area must wear appropriate respiratory protection. Always wear a properly fitting respirator, which may include a supplied-air respirator. Ventilate the work area according to instructions in the acid manufacturer’s SDS.
- Avoid all skin contact with acid. Everyone in the work area must wear chemically impermeable gloves, protective clothing, foot coverings, aprons, and face shields as recommended by the acid manufacturer and local regulatory authority. Follow all acid manufacturer recommendations, including those regarding handling of contaminated clothing. Wash hands and face before eating or drinking.
- Regularly inspect equipment for potential leaks and remove spills promptly and completely to avoid direct contact or inhalation of the acid and its vapors.
- Keep acid away from heat, sparks, and open flames. Do not smoke in the work area. Eliminate all ignition sources.
- Store acid in the original container in a cool, dry, and well-ventilated area away from direct sunlight and away from other chemicals in accordance with acid manufacturer’s recommendations. To avoid corrosion of containers, do not store acid in substitute containers. Reseal the original container to prevent vapors from contaminating the storage space and surrounding facility.

## Moisture Sensitivity of Acid Catalysts

Acid catalysts can be sensitive to atmospheric moisture and other contaminants. It is recommended the catalyst pump and valve seal areas exposed to atmosphere are flooded with ISO oil, TSL, or other compatible material to prevent acid build-up and premature seal damage and failure.

<b>NOTICE</b>
<p>Acid build-up will damage the valve seals and reduce the performance and life of the catalyst pump. To prevent exposing acid to moisture:</p> <ul style="list-style-type: none"> <li>• Always use a sealed container with a desiccant dryer in the vent, or a nitrogen atmosphere. Never store acids in an open container.</li> <li>• Keep the catalyst pump and the valve seals filled with the appropriate lubricant. The lubricant creates a barrier between the acid and the atmosphere.</li> <li>• Use only moisture-proof hoses compatible with acids.</li> <li>• Always lubricate threaded parts with an appropriate lubricant when reassembling.</li> </ul>



# Setup

## Pump Components

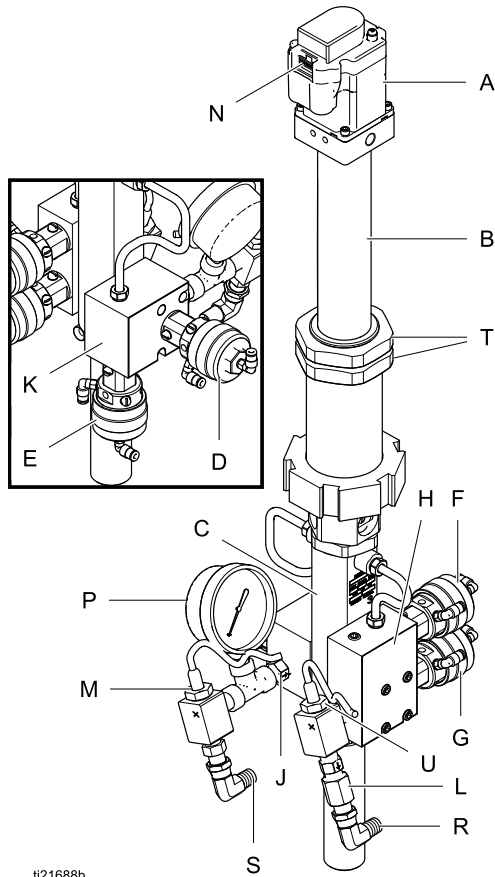

ti21688b

Figure 3 Pump Components

Component	Description
A	Stepper Motor
B	Driver
C	Pump Lower
D	Up Inlet Dose Valve
E	Down Inlet Dose Valve
F	Up Outlet Dose Valve
G	Down Outlet Dose Valve
H	Fluid Outlet Manifold
J	Fluid Inlet Check Valve
K	Fluid Inlet Manifold
L	Fluid Outlet Check Valve
M	Fluid Inlet Pressure Sensor
N	Cable Connection to Pump Control Module
P	Fluid Inlet Pressure Gauge
R	Fluid Outlet Fitting (1/4 npt(m))
S	Fluid Inlet Fitting (1/4 npt(m))
T	Jam Nuts, for mounting pump
U	Fluid Outlet Pressure Sensor

## Air Connections

5/32 in. (4 mm) tubing connects the solenoid manifold to the pump's dosing valves. See the Pump Tubing Schematic on the next page.

**NOTE:** Tubing lengths must be 18 in.  $\pm$  1/2 in. (457 mm  $\pm$  13 mm) for all connections. Always use equal lengths of tubing, to balance the timing of the valves. Lengths longer than 18 in. (457 mm) will increase valve response time.

1. On the bottom of the solenoid manifold are four ports with tube fittings: UP OPEN, UP CLOSED, DOWN OPEN, and DOWN CLOSED. These ports provide air to open and close the pump's inlet dosing valves.

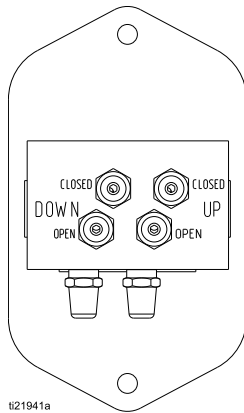

Figure 4 Tubing Connections at Solenoid Manifold, to Pump Inlet Manifold

- a. Connect green tubing (G) from the UP OPEN fitting to the 90° tube fitting on the side of the INLET UP dosing valve.
- b. Connect red tubing (R) from the UP CLOSED fitting to the 90° tube fitting on the end of the INLET UP dosing valve.
- c. Connect black tubing (K) from the DOWN OPEN fitting to the 90° tube fitting on the side of the INLET DOWN dosing valve.
- d. Connect red tubing (R) from the DOWN CLOSED fitting to the 90° tube fitting on the end of the INLET DOWN dosing valve.

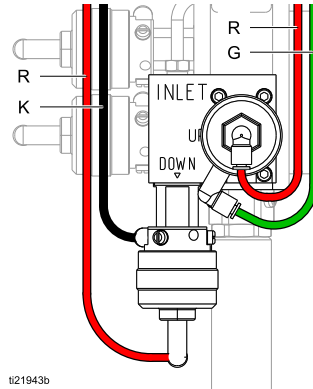

Figure 5 Inlet Manifold Tubing Connections

2. On the side of the solenoid manifold are four ports with 90° tube fittings (not shown): UP OPEN, UP CLOSED, DOWN OPEN, and DOWN CLOSED. These ports provide air to open and close the pump's outlet dosing valves.

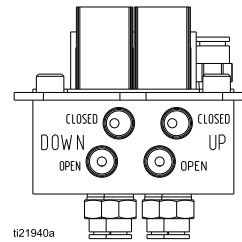

Figure 6 Tubing Connections at Solenoid Manifold, to Pump Outlet Manifold

- a. Connect blue tubing (B) from the UP OPEN fitting to the 90° tube fitting on the side of the OUTLET UP dosing valve.
- b. Connect red tubing (R) from the UP CLOSED fitting to the 90° tube fitting on the end of the OUTLET UP dosing valve.

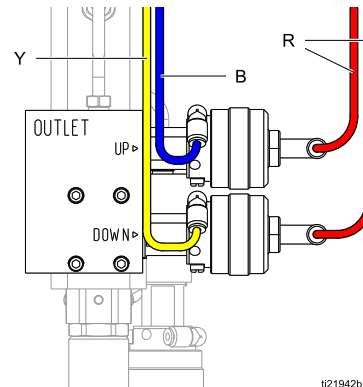

Figure 7 Outlet Manifold Tubing Connections



- c. Connect yellow tubing (Y) from the DOWN OPEN fitting to the 90° tube fitting on the side of the OUTLET DOWN dosing valve.
  - d. Connect red tubing (R) from the DOWN CLOSED fitting to the 90° tube fitting on the end of the OUTLET DOWN dosing valve.
3. Repeat these steps for each pump in your system.

See the following table to understand the relationship between pump stroke and dose valve actuation.

**Table 1 Dose Valve Actuation**

Pump Stroke	Up Inlet Valve	Down Inlet Valve	Up Outlet Valve	Down Outlet Valve
Up	Open	Closed	Open	Closed
Down	Closed	Open	Closed	Open

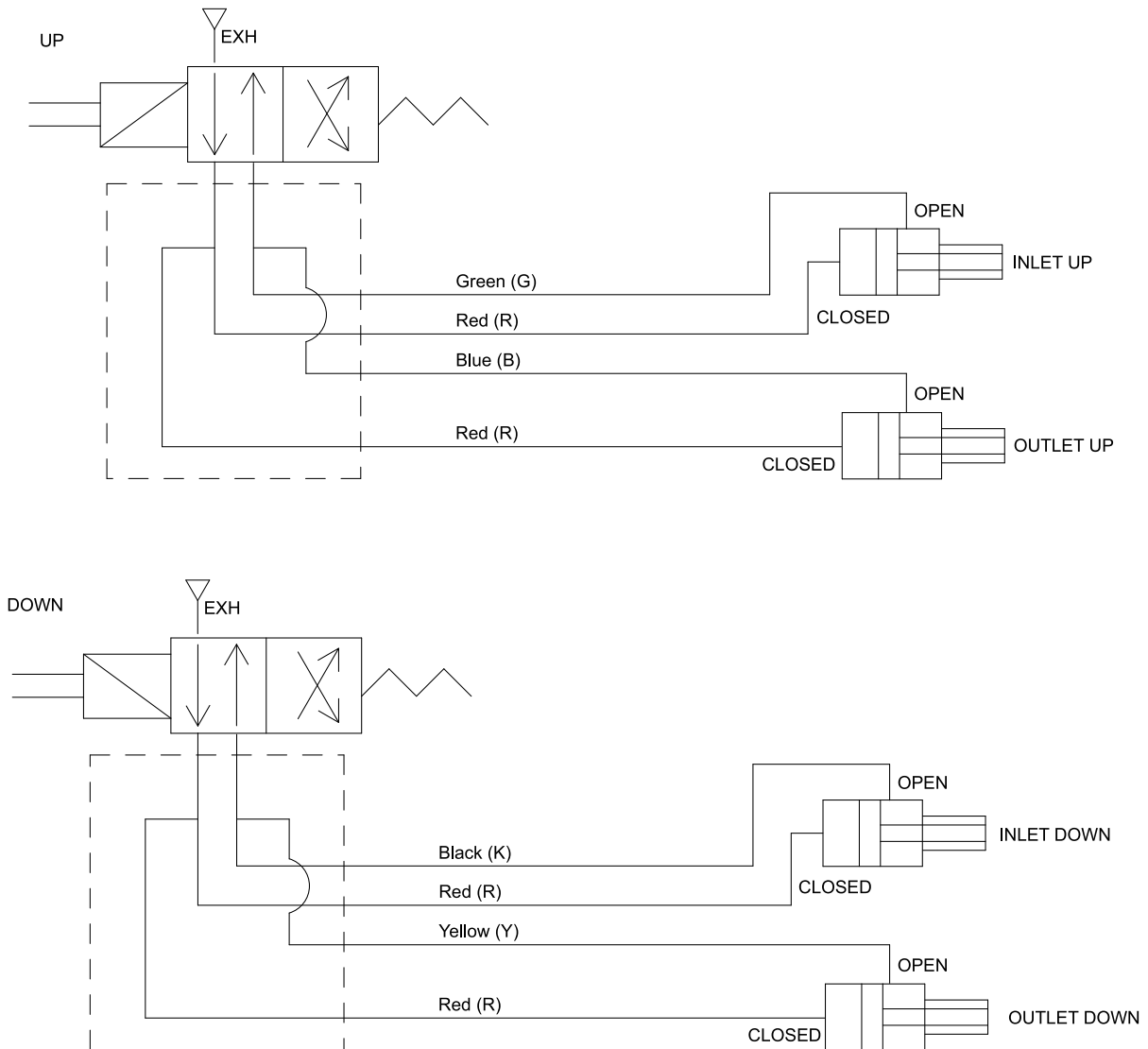
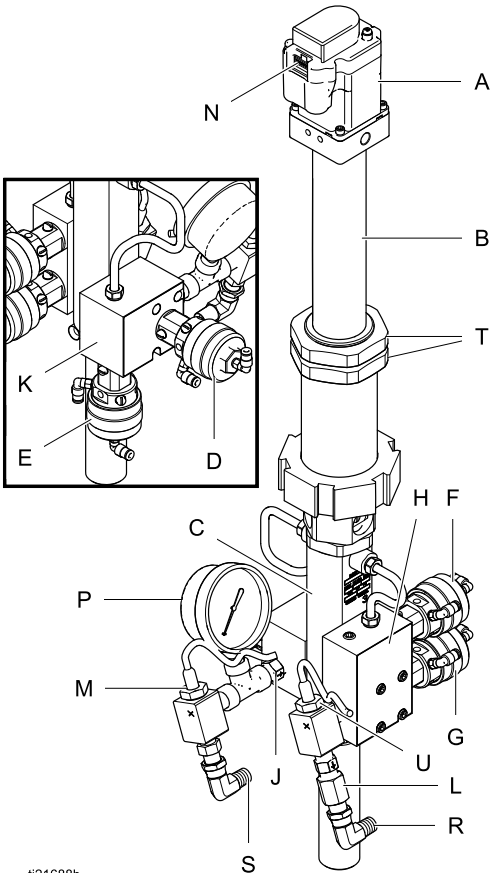

Figure 8 Pump Tubing Schematic

## Fluid Connections

1. Connect a 1/4 npt(f) fluid hose from the fluid source to the check valve (J) at the pump's fluid inlet manifold (K). The inlet dose valves (D, E) will open and close alternately at the pump stroke changeover, to maintain a steady flow into the pump.
2. Connect a 1/4 npt(f) fluid outlet hose from the check valve (L) at the pump's fluid outlet manifold (H). The outlet dose valves (F, G) will open and close alternately at the pump stroke changeover, to maintain a steady flow out of the pump.



ti21688b

Figure 9 Fluid Connections

## Electrical Connection

### NOTICE

To avoid electrical component damage, remove all system power before plugging any connectors.

Connect the cable from the pump control module in the proportioner's electrical control box to the cable connector (N) on the pump motor (A).





The cable has two connectors, one for the motor control and the other for encoder feedback. The connectors are keyed differently to ensure correct installation.

# Repair

## Preventive Maintenance Schedule

The operating conditions of your particular system determine how often maintenance is required. Establish a preventive maintenance schedule by recording when and what kind of maintenance is needed, and then determine a regular schedule for checking your system.

## Disconnect the Lower from the Driver

				
<p>This equipment stays pressurized until pressure is manually relieved. To help prevent serious injury from pressurized fluid such as skin injection, splashing fluid, and moving parts, follow the <b>Pressure Relief Procedure</b> in your system manual when you stop spraying and before cleaning, checking, or servicing the equipment.</p>				

1. Follow the **Pressure Relief Procedure** in your proportioner manual. Stop the pump at the bottom of its stroke.
2. Remove the pump from the proportioner, as explained in your proportioner manual.
3. Remove the TSL inlet fitting (17) and set aside.
4. Unscrew the connecting nut (207).
5. Move the o-ring (106) down onto the pump piston rod (2) to allow access to the pin (103). Remove the pin.

**NOTE:** If you are only repairing the piston rod (2) and its packings, it is not necessary to completely remove the lower from the driver. After removing the pin (103), go to [Disassemble the Lower, page 14](#) and push the rod down out of the cylinder. Disassemble the piston rod as explained there.

6. Disconnect all air and fluid lines from the dosing valves and manifolds. Be sure to label the lines to ensure they are re-connected correctly.
7. Pull the lower away from the driver.
  - a. To service the driver, see [Driver Repair, page 12](#).
  - b. To service the lower, see [Lower Repair, page 14](#).

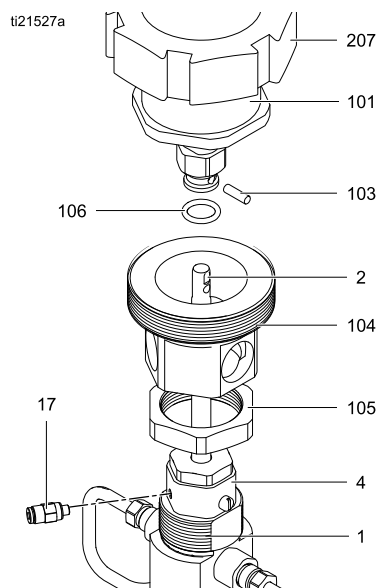

Figure 10 Disconnect the Lower from the Driver

## Driver Repair

### Remove the Driver

1. See [Disconnect the Lower from the Driver, page 11](#).
2. Remove the four screws (201e) and remove the motor (202) from the actuator (201). The motor-side coupler (201a) and insert (201b) will come off with the motor.

### Install the Driver

#### **NOTICE**

To prevent possible damage to the motor, the motor-side coupler (201a) surface must be flush with the end of the motor shaft.

1. Check that the motor-side coupler (201a) surface is flush with the end of the motor shaft. Torque the two screws (201c) to 35–45 in-lb (4–5 N•m).
2. Ensure that the coupler insert (201b) is in place. Mount the motor (202) onto the actuator so the two couplers engage. Inspect the motor-to-actuator fit; the motor **must** rest flat on the actuator housing.

#### **NOTICE**

If the motor does not rest flat on the actuator housing, determine the cause and correct before installing the screws (201d). An incorrect fit will create a thrust load on the motor shaft, which will cause motor failure if operated.

3. Install the four screws (201d).
4. See [Reconnect the Lower to the Driver, page 18](#).

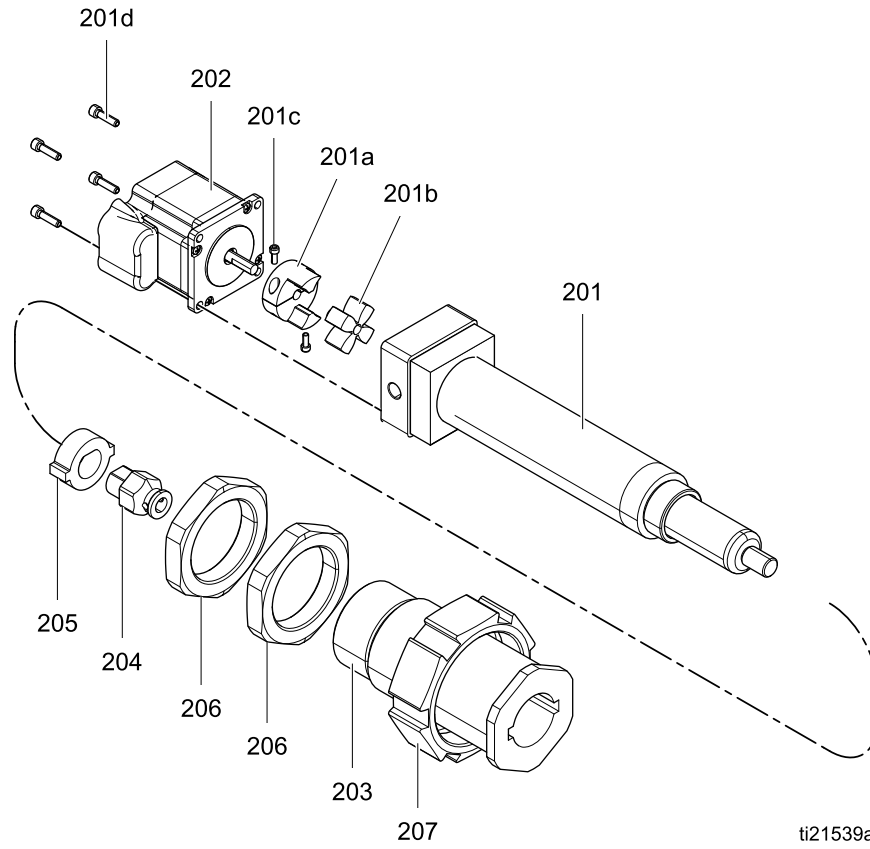

Figure 11 Driver Assembly

ti21539a

## Lower Repair

### Disassemble the Lower

1. Remove the lower from the driver; see [Disconnect the Lower from the Driver, page 11](#).
2. Remove the top and bottom throat cartridges (4) to expose the piston rod (2a/2b).
3. Push the piston rod assembly down out the bottom of the cylinder (1).
4. Disassemble the piston rod (2a, 2b), using the flats on both ends. Remove the piston parts (12–16, 42) from the lower rod (2b).
5. Unscrew the upper packing nut (5) from the upper throat cartridge (4). Remove the o-rings (7), packings (10), and bearing (11).
6. Remove the rod guard (8). Unscrew the lower packing nut (6) from the lower throat cartridge (4). Remove the o-rings (7), packings (10), and bearing (11).
7. Unscrew the dosing valves (25) from the manifolds (19 and 20). Remove the seats (23) and o-rings (22, 24).
8. Disconnect the inlet (29) and outlet (28) tubes at the cylinder (1). Remove the adapters (27) and o-rings (33).
9. Remove the screws (26) holding the manifolds (19, 20) to the cylinder (1). Remove the o-rings (21).
10. Clean and inspect all parts.

**NOTE:** The 70 cc lower 24T793 includes two u-cups (10) in the lower throat cartridge; the 35 cc lower 24T792 includes one.

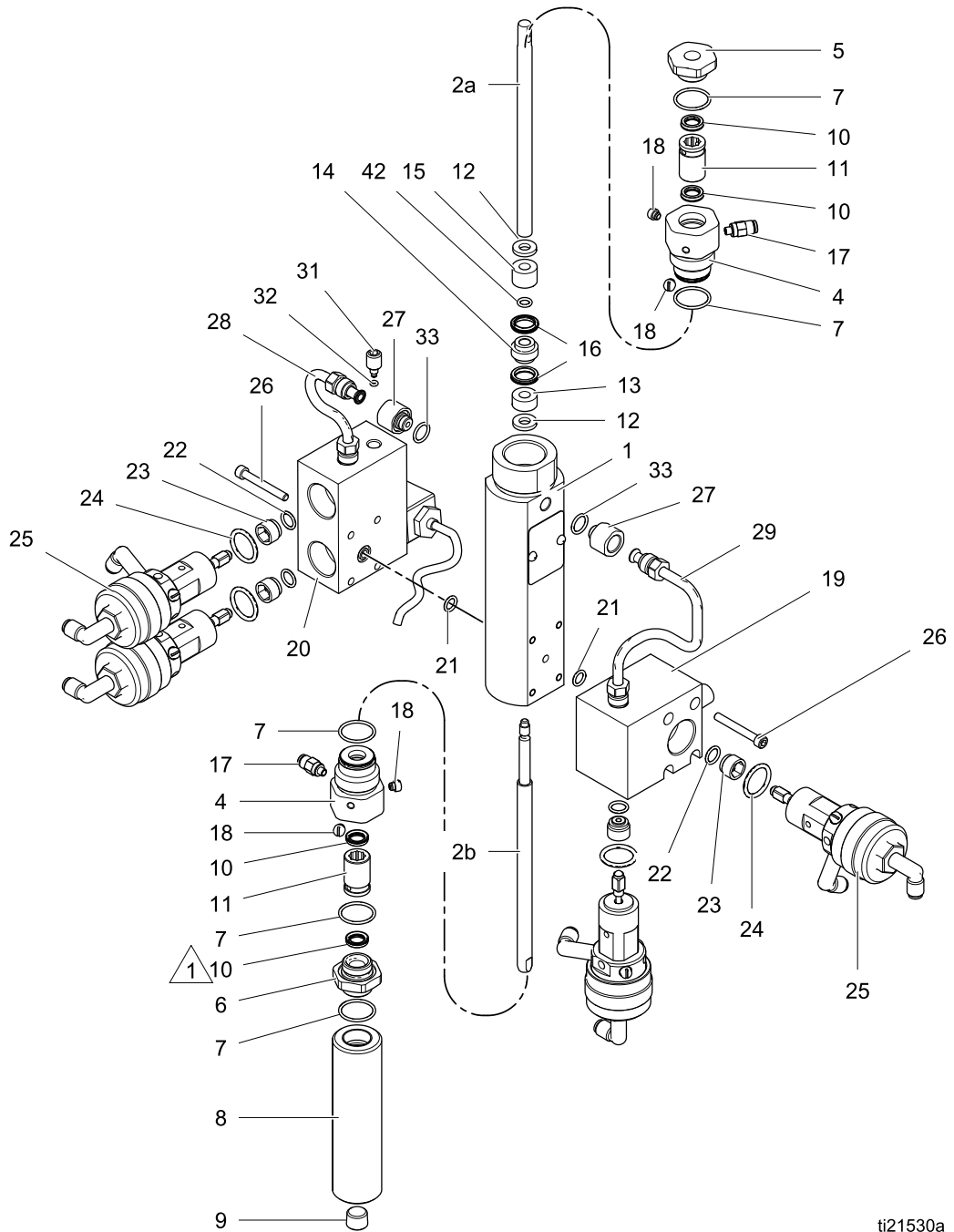

Figure 12 Lower Pump Assembly

ti21530a

## Reassemble the Lower

1. Install the manifolds (19, 20) on the cylinder (1). Lubricate the o-rings (21) and ensure they are in place on the mating surfaces. Apply thread adhesive to the screws (26) and torque to 13–23 in-lb (1.5–2.5 N•m).
2. Lubricate the o-rings (33). Apply thread lubricant and install the adapters (27) and o-rings (33) on the cylinder (1). Connect the inlet (29) and outlet (28) tubes at the cylinder (1).
3. Lubricate the o-rings (22, 24). Install the o-rings (22), seats (23), and o-rings (24) in the manifolds (19 and 20). Apply thread lubricant and screw the dosing valves (25) into the manifolds. Torque to 20–30 ft-lb (28–40 N•m).
4. Lubricate the piston packings (16) and o-ring (42). Assemble the piston on the lower rod (2b) as follows:
  - a. Install one washer (12) and the bottom (shorter) spacer (13).
  - b. Install one packing (16) on each shoulder of the piston bearing (14), with the lips facing away from the bearing. Install the piston bearing (14).
  - c. Install the o-ring (42), the top (longer) spacer (15), and one washer (12).

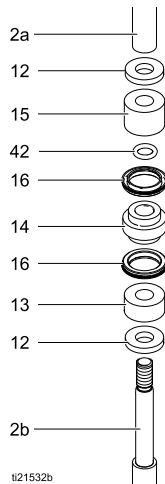

Figure 13 Piston Rod Assembly

5. Apply thread adhesive to the male threads of the lower rod (2b). Screw the upper piston rod (2a) onto the lower rod, using the flats on both ends. Torque to 35–45 in-lb (4–5 N•m).
6. Insert the piston rod assembly into the cylinder (1) from the bottom. Push the rod up until it protrudes from the top of the cylinder (1).
 

**NOTE:** The 70 cc lower 24T793 includes two u-cup packings (10) in the lower throat cartridge; the 35 cc lower 24T792 includes only the upper one.
7. Lubricate the o-rings (7) and packing(s) (10). Place the upper packing (10) into the tool (T) included with the seal kit. The lips of the packing must face out of the tool. Insert the tool into the lower throat cartridge (4). Push on the tool's shaft (P) to seat the packing securely in the cartridge. When seated, the lips of the packing will be facing up. Install the bearing (11). On 70 cc lowers only, install the second packing (10) with the lips also facing up.

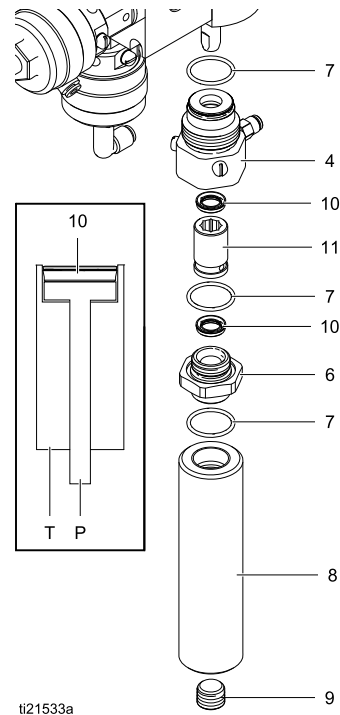

Figure 14 Lower Throat Assembly



8. Install the o-rings (7) on the lower packing nut (6). Screw the packing nut into the lower throat cartridge (4). Torque to 20–30 ft-lb (28–40 N•m).
9. Slide the lower packing cartridge (4) onto the piston rod (2) and screw the cartridge into the cylinder (1). Torque to 35–45 ft-lb (48–61 N•m).
10. Screw the rod guard (8) securely onto the lower packing nut (6). Make sure the plug (9) is in place at the bottom of the rod guard.
11. Lubricate the o-rings (7) and packing(s) (10). Place one packing (10) into the tool (T) included with the seal kit. The lips of the packing must face out of the tool. Insert the tool into the upper throat cartridge (4). Push on the tool's shaft (P) to seat the packing securely in the cartridge. When seated, the lips of the packing will be facing down. Install the bearing (11). Install the second packing (10) with the lips facing down.
12. Install the o-ring (7) on the upper packing nut (5). Screw the packing nut into the upper throat cartridge (4). Torque to 20–30 ft-lb (28–40 N•m).
13. Slide the upper packing cartridge (4) onto the piston rod (2) and screw the cartridge into the cylinder (1). Torque to 35–45 ft-lb (48–61 N•m).
14. Install the lower on the driver; see [Reconnect the Lower to the Driver, page 18](#).

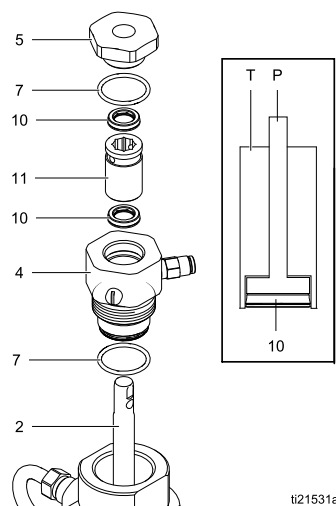

Figure 15 Upper Throat Assembly

## Reconnect the Lower to the Driver

1. Ensure that the air fitting (17) is removed and set aside.
2. Screw the jam nut (105) and connector (104) onto the pump cylinder (1), all the way to the bottom of the threads.
3. Align the holes in the connector (104) with the ports in the throat cartridge (4).
4. Torque the jam nut (105) to 65–75 ft-lb (88–101 N•m).
5. Reinstall the TSL inlet fitting (17) in the open port.
6. Place the o-ring (106) on the piston rod (2).
7. Align the holes in the motor shaft and piston rod. Install the pin (103).
8. Slide the o-ring (106) up off the piston rod and into the groove on the motor shaft, covering the pin.
9. Screw the connecting nut (207) onto the connector (104). Torque to 45–55 ft-lb (61–74 N•m).
10. Reinstall the pump on the proportioner, as explained in your proportioner manual.

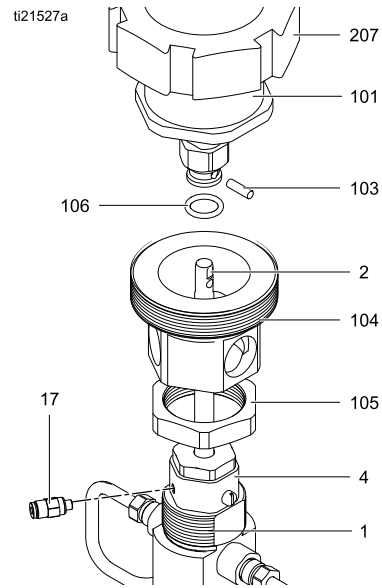

Figure 16 Reconnect the Lower to the Driver

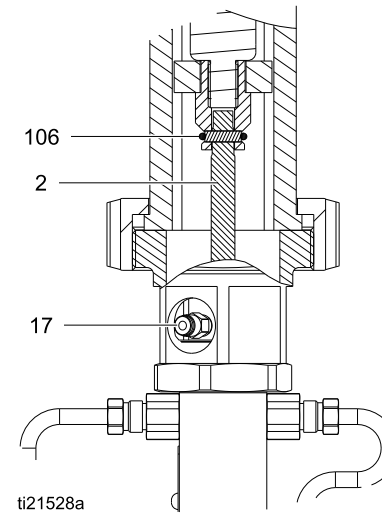

Figure 17 Orient the Lower to the Driver



# Parts

## Pump Assembly

- 24T788, Series A, 35 cc Low Pressure Pump
- 24T789, Series A, 35 cc High Pressure Pump
- 24T790, Series A, 70 cc Low Pressure Pump
- 24T791, Series A, 70 cc High Pressure Pump
- 24T818, Series A, 35 cc Low Pressure Pump (Acid)
- 24T819, Series A, 35 cc High Pressure Pump (Acid)

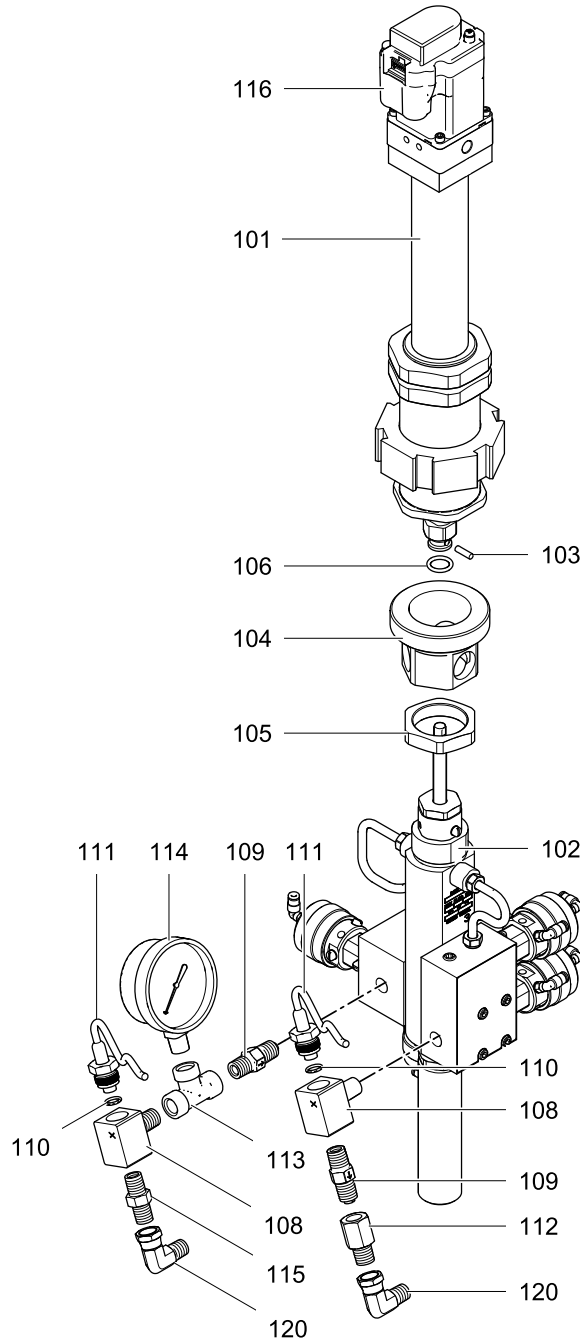

ti21526d

**24T788, Series A, 35 cc Low Pressure Pump**  
**24T789, Series A, 35 cc High Pressure Pump**  
**24T790, Series A, 70 cc Low Pressure Pump**  
**24T791, Series A, 70 cc High Pressure Pump**  
**24T818, Series A, 35 cc Low Pressure Pump (Acid)**  
**24T819, Series A, 35 cc High Pressure Pump (Acid)**

Ref	Part	Description	Qty	Ref	Part	Description	Qty
101	24T794	DRIVER, low pressure; Models 24T788, 24T790, and 24T818; see <a href="#">Pump Driver Assembly, page 26</a>	1	111	26A263	SENSOR, fluid pressure (24T788, 24T790, and 24T818); includes 108 and 110	2
	24T795	DRIVER, high pressure; Models 24T789, 24T791, and 24T819; see <a href="#">Pump Driver Assembly, page 26</a>	1		26A264	SENSOR, fluid pressure (24T789, 24T791, and 24T819); includes 108 and 110	2
102	24T792	LOWER, pump, 35 cc; Models 24T788 and 24T789; see <a href="#">Lower Pump Assembly, page 23</a>	1	112	17A106	ADAPTER; 1/4 npt (m x f); sst	1
	24T793	LOWER, pump, 70 cc; Models 24T790 and 24T791; see <a href="#">Lower Pump Assembly, page 23</a>	1	113	104984	TEE; 1/4 npt (f)	1
	24T796	LOWER, pump, 35 cc; Models 24T818 and 24T819; see <a href="#">Lower Pump Assembly, page 23</a>	1	114	187876	GAUGE, pressure, fluid (24T788, 24T790, and 24T818)	1
103	16N762	PIN, coupler	1		112941	GAUGE, pressure, fluid (24T789, 24T791, and 24T819)	1
104	16N744	CONNECTOR	1	115	121907	NIPPLE; 1/4 npt	1
105	16N748	NUT, jam	1	116	16P037	MOTOR, stepper, low pressure (24T788, 24T790, and 24T818)	1
106	115485	O-RING	1		16P036	MOTOR, stepper, high pressure (24T789, 24T791, and 24T819)	1
108	16F164	FITTING, sensor, pressure	2	120	17R502	FITTING, elbow, swivel; 1/4 npt-npsm	2
109	24T310	VALVE, check	2				
110	121399	O-RING; chemically resistant	2				

## Pump Assembly (Isolated)

24W273, Series A, 35 cc Low Pressure Pump  
 24W303, Series A, 35 cc High Pressure Pump  
 24W274, Series A, 70 cc Low Pressure Pump  
 24W304, Series A, 70 cc High Pressure Pump

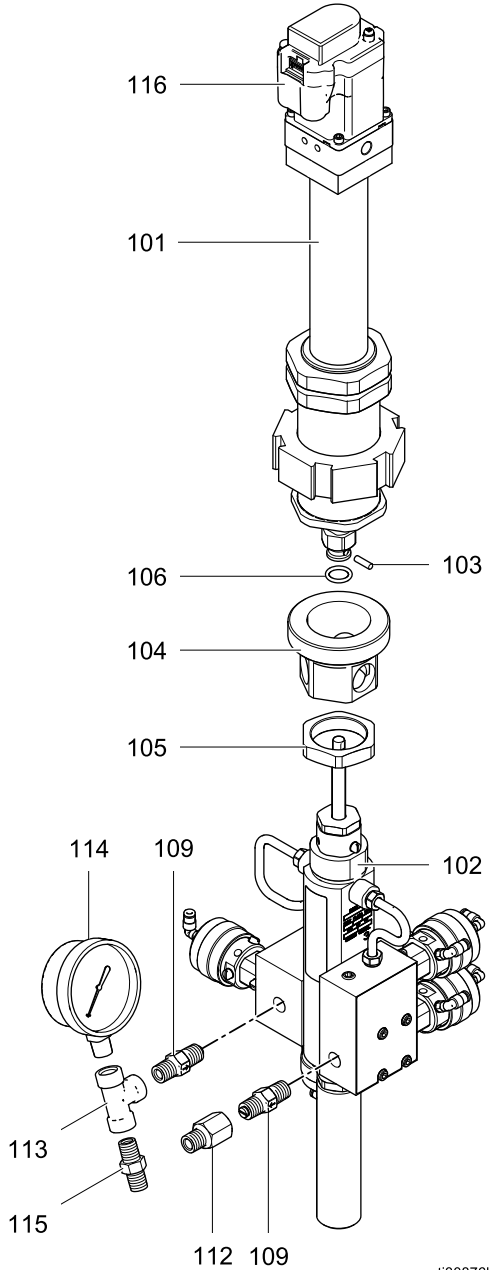

ti30876b

Ref	Part	Description	Qty
101	24T794	DRIVER, low pressure; Models 24W273 and 24W274; see <a href="#">Pump Driver Assembly, page 26</a>	1
	24T795	DRIVER, high pressure; Models 24W303 and 24W304; see <a href="#">Pump Driver Assembly, page 26</a>	1
102	24T792	LOWER, pump, 35 cc; Models 24W273 and 24W303; see <a href="#">Lower Pump Assembly, page 23</a>	1
	24T793	LOWER, pump, 70 cc; Models 24W274 and 24W304; see <a href="#">Lower Pump Assembly, page 23</a>	1
103	16N762	PIN, coupler	1
104	16N744	CONNECTOR	1
105	16N748	NUT, jam	1
106	115485	O-RING	1
109	24T310	VALVE, check	2
112	17A106	ADAPTER; 1/4 npt (m x f); sst	1
113	104984	TEE; 1/4 npt (f)	1
114	187876	GAUGE, pressure, fluid (24W273 and 24W274)	1
	112941	GAUGE, pressure, fluid (24W303 and 24W304)	1
115	121907	NIPPLE; 1/4 npt	1
116	16P037	MOTOR, stepper, low pressure (24W273 and 24W274)	1
	16P036	MOTOR, stepper, high pressure (24W303 and 24W304)	1

## Lower Pump Assembly

24T792, Series A, 35 cc Lower  
 24T793, Series A, 70 cc Lower  
 24T796, Series A, 35 cc Lower (Acid)

 A fourth u-cup (10) is used in this position on Model 24T793 only.

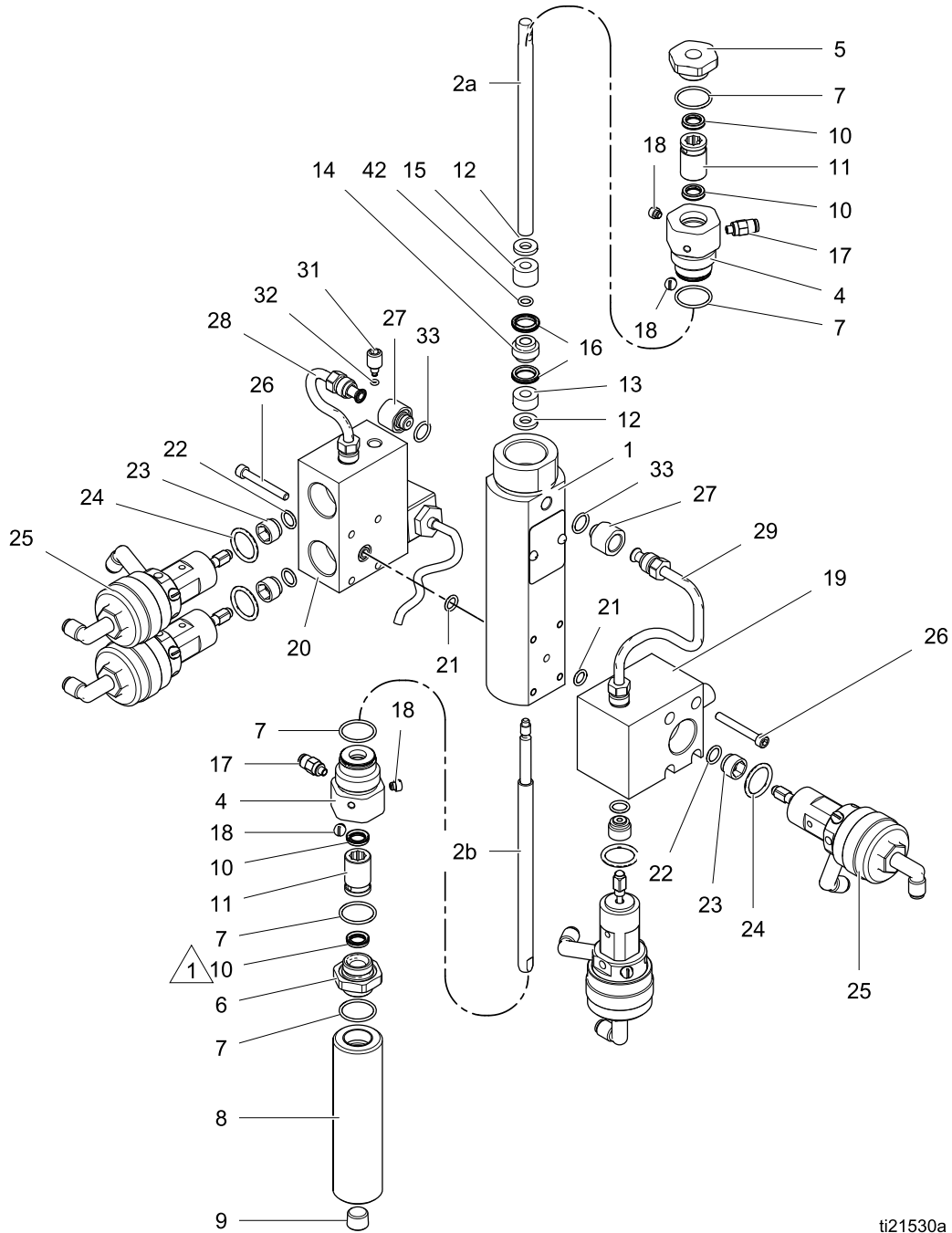

ti21530a

Parts

24T792, Series A, 35 cc Lower  
 24T793, Series A, 70 cc Lower  
 24T796, Series A, 35 cc Lower (Acid)

Ref	Part	Description	Qty	Ref	Part	Description	Qty
1	24U604	CYLINDER, 35 cc; Model 24T792	1	17	111328	CONNECTOR, male; 10-32 x 5/32 in. (4 mm) OD tube	2
	24U605	CYLINDER, 70 cc; Model 24T793	1	18	104644	PLUG, screw; 10-32	4
	17A572	CYLINDER, 35 cc; Model 24T796	1	19	24T810	MANIFOLD, inlet; includes items 22 and 23; Model 24T792 and 24T793	1
2	24T842	KIT, piston rod assembly; includes items 2a and 2b	1		26A033	MANIFOLD, inlet; includes items 22 and 23; Model 24T796	1
2a	— — —	ROD, piston, upper	1				
2b	— — —	ROD, piston, lower	1				
4	16N750	FITTING, throat cartridge; Model 24T792 and 24T793	2	20	24T811	MANIFOLD, outlet; includes items 22 and 23; Model 24T792 and 24T793	1
	17H370	FITTING, throat cartridge; Model 24T796	2		26A032	MANIFOLD, outlet; includes items 22 and 23; Model 24T796	1
5	16N751	NUT, packing, upper	1				
6	16T350	NUT, packing, lower	1				
7	* †★	O-RING; ptfe	5	21	* †	O-RING; ptfe	2
8	16T352	GUARD, rod; Model 24T792	1	22	* † ◆	O-RING; ptfe	4
	16T351	GUARD, rod; Model 24T793	1	23	◆	RETAINER, seat, valve	4
	17K645	GUARD, rod; Model 24T796	1	24	* † ◆	O-RING; ptfe	4
9	100361	PLUG, pipe; 1/2 npt	1	25	26A355	VALVE, dispense; see manual 312782; Model 24T792 and 24T793	4
10	— — —	PACKING, throat, u-cup; UHMWPE;			24T785	VALVE, dispense; see manual 312782; Model 24T796	4
	*★	For Model 24T792	3				
	†★	For Model 24T793	4	26	104472	SCREW, cap, socket head; 10-32 x 1.5 in. (38 mm)	8
11	* †★	BEARING, throat	2				
12	* †	WASHER, piston	2				
13	— — —	SPACER, piston, bottom		27	‡	ADAPTER, pump	2
	*	For Model 24T792	1	28	‡	TUBE, outlet	1
	†	For Model 24T793	1	29	‡	TUBE, inlet	1
14	— — —	BEARING, piston		31	— — —	PLUG, pump	1
	*	For Model 24T792	1	32	* †	O-RING; ptfe	1
	†	For Model 24T793	1	33	* †‡	O-RING; ptfe	2
15	— — —	SPACER, piston, top		42	* †	O-RING; chemically resistant	1
	*	For Model 24T792	1				
	†	For Model 24T793	1				
16	— — —	PACKING, piston, u-cup; UHMWPE					
	*	For Model 24T792	2				
	†	For Model 24T793	2				



Items marked — — — are not available separately.

\* Included in 35 cc Lower Seal Repair Kits 24T840 and 24T895, which must be purchased separately. (See Repair Kits table for difference between the kits.)

† Included in 70 cc Lower Seal Repair Kits 24T841 and 24T896, which must be purchased separately. (See Repair Kits table for difference between the kits.)

◆ Included in Dosing Valve Seat Replacement Kit 24T843, which must be purchased separately.

‡ Included in Tube Assembly Kit 24T822, which must be purchased separately.

★ Included in Throat Seal Replacement Kit 26C415, which must be purchased separately.

#### Kits for Acid Model 24T796

Part No.	Description
24T785	Acid Valve Replacement Kit (includes ref. 22, 23, 24, and 25).
24T817	Acid Valve Rebuild Kit for valve 24T785 (PEEK seat retainer)
25N725	Alternate Acid Valve Rebuild Kit for valve 24T785 (17-4 PH SST seat retainer)
26A035	Valve Seat Kit (includes PEEK seat ref. 23, with o-rings ref. 22 and 24).
26A034	Acid Pump Tubes Kit (includes ref. 27, 28, 29, and 33).

## Pump Driver Assembly

**24T794, Series A, Low Pressure Pump Driver without Stepper Motor**  
**24T795, Series A, High Pressure Pump Driver without Stepper Motor**

**NOTE:** Each pump driver assembly includes Ref. No. 201 through 207, preassembled.

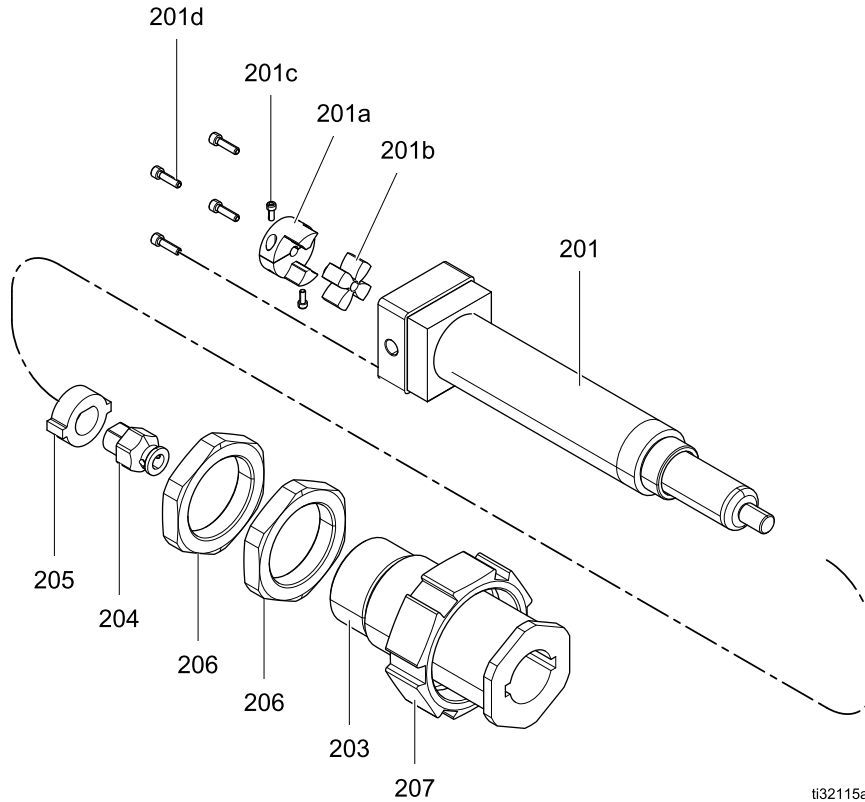

ti32115a

Ref	Part	Description	Qty	Ref	Part	Description	Qty
201	24T794	ACTUATOR, linear; for 24T794	1	204	---	NUT, coupling; for 24T794	1
	24T795	ACTUATOR, linear; for 24T795	1		---	NUT, coupling; for 24T795	1
201a	---	COUPLER	1	205	---	GUIDE, rod; for 24T794	1
201b	---	INSERT, coupler	1		---	GUIDE, rod; for 24T795	1
201c	---	SCREW, coupler	2	206	---	NUT, jam	2
201d	---	SCREW, motor mounting	4	207	---	NUT, connecting	1
203	---	HOUSING, actuator; for 24T794	1				
	---	HOUSING, actuator; for 24T795	1				

Items marked --- are not available separately and are available only as part of the assembly due to possible damage to the actuator during disassembly and reassembly.

## Repair Kits, Related Manuals, and Accessories

Description	Kit Part No.	Kit Description
All pumps in this manual.	24T843	Dosing Valve Seat Replacement Kit. Includes seats and o-rings for all four dosing valves on a pump.
	24T302	TSL Cup Kit
	24T303	Throat Seal Installation Tool. Also included in Seal Kits 24T840 and 24T841.
	26C415	Throat Seal Replacement Kit. No tools included.
Model 24T792 35 cc Lower	24T840	Pump Seal Repair Kit. Includes 24T303 Throat Seal Installation Tool.
Model 24T793 70 cc Lower	24T841	Pump Seal Repair Kit. Includes 24T303 Throat Seal Installation Tool.
Model 24T792 35 cc Lower	24T895	Pump Seal Repair Kit. No tools included.
Model 24T793 70 cc Lower	24T896	Pump Seal Repair Kit. No tools included.

# Dimensions

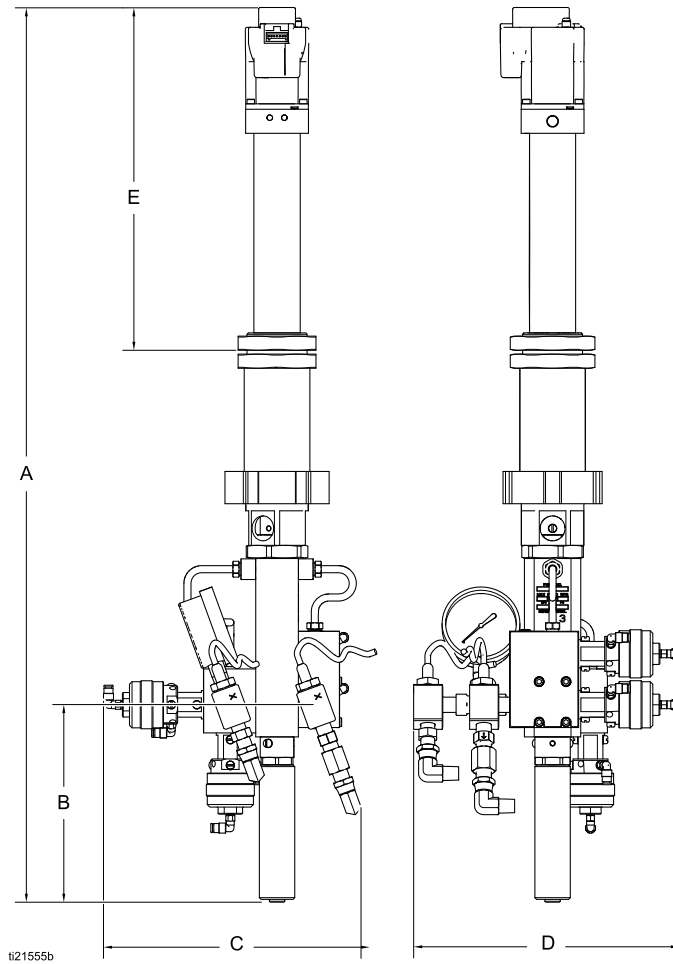

Pump Model	A, in. (mm)	B, in. (mm)	C, in. (mm)	D, in. (mm)	E, in. (mm)
24T788, 24T789, 24T818, 24T819	33.0 (838)	7.375 (187)	8.25 (210)	9.7 (246)	13.375 (340)
24T790, 24T791	34.25 (870)	7.375 (187)	8.25 (210)	9.7 (246)	14.50 (368)
24W273, 24W303	33.0 (838)	7.375 (187)	8.25 (210)	8.6 (218)	13.375 (340)
24W274, 24W304	34.25 (870)	7.375 (187)	8.25 (210)	8.6 (218)	14.50 (368)

# Technical Data

Dosing Pumps	U.S.	Metric
Maximum fluid working pressure:		
24T788, 24T790, 24T818, 24W273, and 24W274	300 psi	2.1 MPa, 21 bar
24T789, 24T791, 24T819, 24W303, and 24W304	1500 psi	10.5 MPa, 105 bar
Maximum working air pressure:	100 psi	0.7 MPa, 7.0 bar
Air supply:	85–100 psi	0.6–0.7 MPa, 6.0–7.0 bar)
Fluids handled:	one or two component: <ul style="list-style-type: none"> <li>• solvent and waterborne paints</li> <li>• polyurethanes</li> <li>• epoxies</li> <li>• acid catalyzed varnishes</li> <li>• moisture sensitive isocyanates</li> </ul>	
Viscosity range of fluid:	20–5000 centipoise	
Fluid inlet size:	1/4 npt(m)	
Fluid outlet size:	1/4 npt(m)	
Air inlet size (dosing valves):	5/32 in. OD tube	4 mm OD tube
Stepper motor	48 Vdc, 4 amp The motor includes an encoder and internal controller requiring step and direction input integration to a PD2K controller or similar control module to operate.	
Operating temperature range:	41–122°F	5–50°C
Weight:		
24T788, 24T790, 24T818, 24W273, and 24W303	21.2 lb	9.6 kg
24T789, 24T791, 24T819, 24W274, and 24W304	23.5 lb	10.7 kg
Sound data:	Less than 75 dB(A)	
Wetted parts:	17–4PH, 303, 304 SST, Tungsten carbide (with nickel binder), perfluoroelastomer; PTFE, PPS, UHMWPE	

# Graco Standard Warranty

Graco warrants all equipment referenced in this document which is manufactured by Graco and bearing its name to be free from defects in material and workmanship on the date of sale to the original purchaser for use. With the exception of any special, extended, or limited warranty published by Graco, Graco will, for a period of twelve months from the date of sale, repair or replace any part of the equipment determined by Graco to be defective. This warranty applies only when the equipment is installed, operated and maintained in accordance with Graco's written recommendations.

This warranty does not cover, and Graco shall not be liable for general wear and tear, or any malfunction, damage or wear caused by faulty installation, misapplication, abrasion, corrosion, inadequate or improper maintenance, negligence, accident, tampering, or substitution of non-Graco component parts. Nor shall Graco be liable for malfunction, damage or wear caused by the incompatibility of Graco equipment with structures, accessories, equipment or materials not supplied by Graco, or the improper design, manufacture, installation, operation or maintenance of structures, accessories, equipment or materials not supplied by Graco.

This warranty is conditioned upon the prepaid return of the equipment claimed to be defective to an authorized Graco distributor for verification of the claimed defect. If the claimed defect is verified, Graco will repair or replace free of charge any defective parts. The equipment will be returned to the original purchaser transportation prepaid. If inspection of the equipment does not disclose any defect in material or workmanship, repairs will be made at a reasonable charge, which charges may include the costs of parts, labor, and transportation.

**THIS WARRANTY IS EXCLUSIVE, AND IS IN LIEU OF ANY OTHER WARRANTIES, EXPRESS OR IMPLIED, INCLUDING BUT NOT LIMITED TO WARRANTY OF MERCHANTABILITY OR WARRANTY OF FITNESS FOR A PARTICULAR PURPOSE.**

Graco's sole obligation and buyer's sole remedy for any breach of warranty shall be as set forth above. The buyer agrees that no other remedy (including, but not limited to, incidental or consequential damages for lost profits, lost sales, injury to person or property, or any other incidental or consequential loss) shall be available. Any action for breach of warranty must be brought within two (2) years of the date of sale.

**GRACO MAKES NO WARRANTY, AND DISCLAIMS ALL IMPLIED WARRANTIES OF MERCHANTABILITY AND FITNESS FOR A PARTICULAR PURPOSE, IN CONNECTION WITH ACCESSORIES, EQUIPMENT, MATERIALS OR COMPONENTS SOLD BUT NOT MANUFACTURED BY GRACO.** These items sold, but not manufactured by Graco (such as electric motors, switches, hose, etc.), are subject to the warranty, if any, of their manufacturer. Graco will provide purchaser with reasonable assistance in making any claim for breach of these warranties.

In no event will Graco be liable for indirect, incidental, special or consequential damages resulting from Graco supplying equipment hereunder, or the furnishing, performance, or use of any products or other goods sold hereto, whether due to a breach of contract, breach of warranty, the negligence of Graco, or otherwise.

## FOR GRACO CANADA CUSTOMERS

The Parties acknowledge that they have required that the present document, as well as all documents, notices and legal proceedings entered into, given or instituted pursuant hereto or relating directly or indirectly hereto, be drawn up in English. Les parties reconnaissent avoir convenu que la rédaction du présente document sera en Anglais, ainsi que tous documents, avis et procédures judiciaires exécutés, donnés ou intentés, à la suite de ou en rapport, directement ou indirectement, avec les procédures concernées.

## Graco Information

For the latest information about Graco products, visit [www.graco.com](http://www.graco.com).

**To place an order**, contact your Graco Distributor or call to identify the nearest distributor.

**Phone:** 612-623-6921 **or Toll Free:** 1-800-328-0211 **Fax:** 612-378-3505

All written and visual data contained in this document reflects the latest product information available at the time of publication.

Graco reserves the right to make changes at any time without notice.

For patent information, see [www.graco.com/patents](http://www.graco.com/patents).

Original Instructions. This manual contains English. MM 332339

**Graco Headquarters:** Minneapolis

**International Offices:** Belgium, China, Japan, Korea

**GRACO INC. AND SUBSIDIARIES • P.O. BOX 1441 • MINNEAPOLIS MN 55440-1441 • USA**

**Copyright 2013, Graco Inc. All Graco manufacturing locations are registered to ISO 9001.**

[www.graco.com](http://www.graco.com)

Revision J, October 2018