

部品



# ExactaBlend™ AGP 高度グレージング プロポーション

332555C

JA

コンポーネントのシリコーン材料のディスペンス用。  
一般目的では使用しないでください。

爆発性雰囲気または危険区域での使用は承認されていません。

最高使用圧力とモデルの情報については、『ExactaBlend AGP 高度グレージングプロポーション、セットアップ - 操作』の取扱説明書を参照してください。



## 重要な安全注意

本説明書のすべての警告と説明、および『ExactaBlend AGP 高度グレージングプロポーション、セットアップ - 操作』の取扱説明書をお読みください。すべての説明書は保管してください。

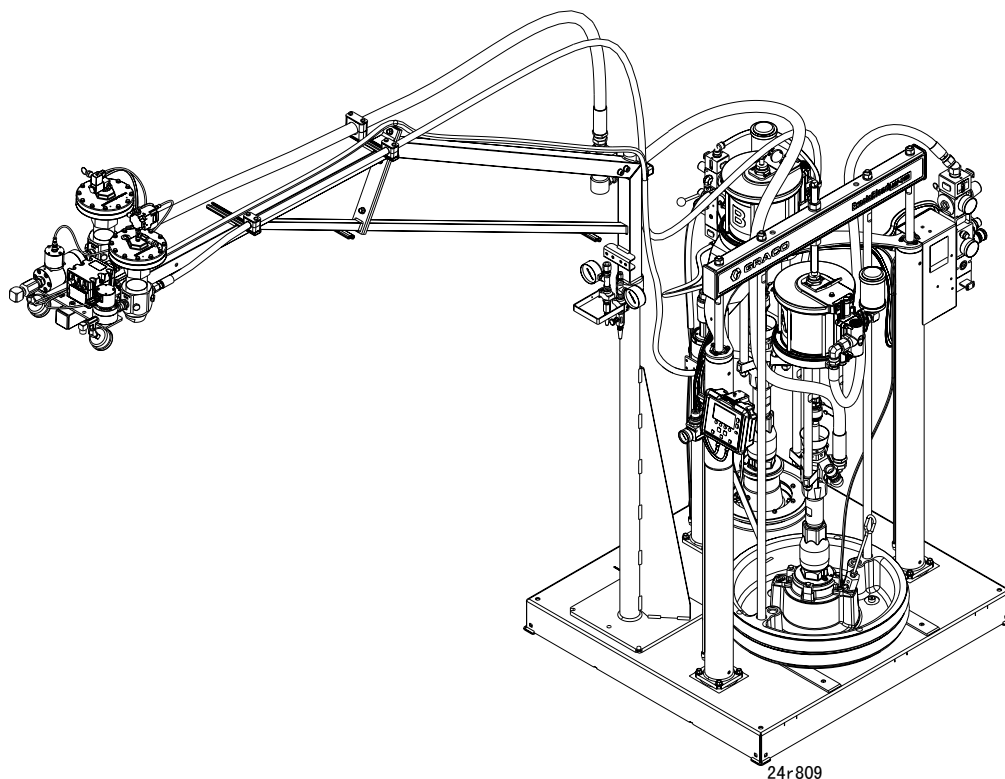

## 関連の説明書

関連の説明書の完全リストについては、『ExactaBlend AGP 高度グレージングプロポーション、セットアップ - 操作』の取扱説明書を参照してください。

## 目次

関連の説明書	2
目次	2
部品	4
ベースマシン	4
ベース	6
208 リットル (55 ガロン) エアシリンダ	12
18.9 リットル (5 ガロン) エアシリンダ	14
電気エンクロージャ	16
Checkmate ポンプ	18
ブームアセンブリ	20
液体プレート	22
24R662 - 多量ホース	24
24R663 - 少量ホース	25
ホースキット	26
24R805, 24R806, 24R822, 24T092, 24T093,	
24T094 - 少量ホースキット	27
24R734 - 多量ホース	28
デispensバルブ	30
24P221 - Ultra-Lite <sup>?</sup> TriCore	30
24R682 - Tri-Core ミキサー	31
24P223 - Ultra-Lite	32
24P217 - MD2	33
Graco Standard Warranty	34
Graco Information	34



# 部品

## ベースマシン



図 1: ベースマシン

参照	部品	説明	数量	
			24R809、 システム、 100cc/100cc、 ブーム	24R810、 システム、 100cc/100cc
1	---	BASE, 55gal/5gal	1	1
2	---	MODULE, boom	1	
3	---	MODULE, fluid plate	1	1
4	24R662	HOSE, assembly, high volume	1	1
5	24R663	HOSE, assembly, low volume	1	1
10	16T924	SOFTWARE, GCA	1	1
17	---	BAR, bracket, ram, DM	1	1
18	---	SCREW, machine, hex flange	4	4
19	---	BRACKET, mounting, assembly	1	1
20	---	SCREW, M5x14mm	2	2
21	---	SCREW, socket head, M5x18mm	1	1
22	24T001	MODULE, GCA, DM	1	1
23	---	BRACKET, mounting, regulator	1	1
24	110341	REGULATOR, air	1	1
25	110209	NUT, regulator	1	1
26	108190	GAUGE, pressure, air	1	1
27	597151	FITTING, elbow	2	2
28	100139	PLUG, pipe	1	1
29	116654	FITTING, tube, swivel, male elbow	1	1
30	115287	FITTING, Y tube	1	1
31	---	TUBE, nylon	28.2 ft	28.2 ft
32	120952	CABLE, CAN, female / female	1	1
33	---	SLEEVE, protective, poly, black	12 ft	12 ft
37	206995	FLUID, TSL, 1 quart	1	1

--- 別売りされていません。

ベース

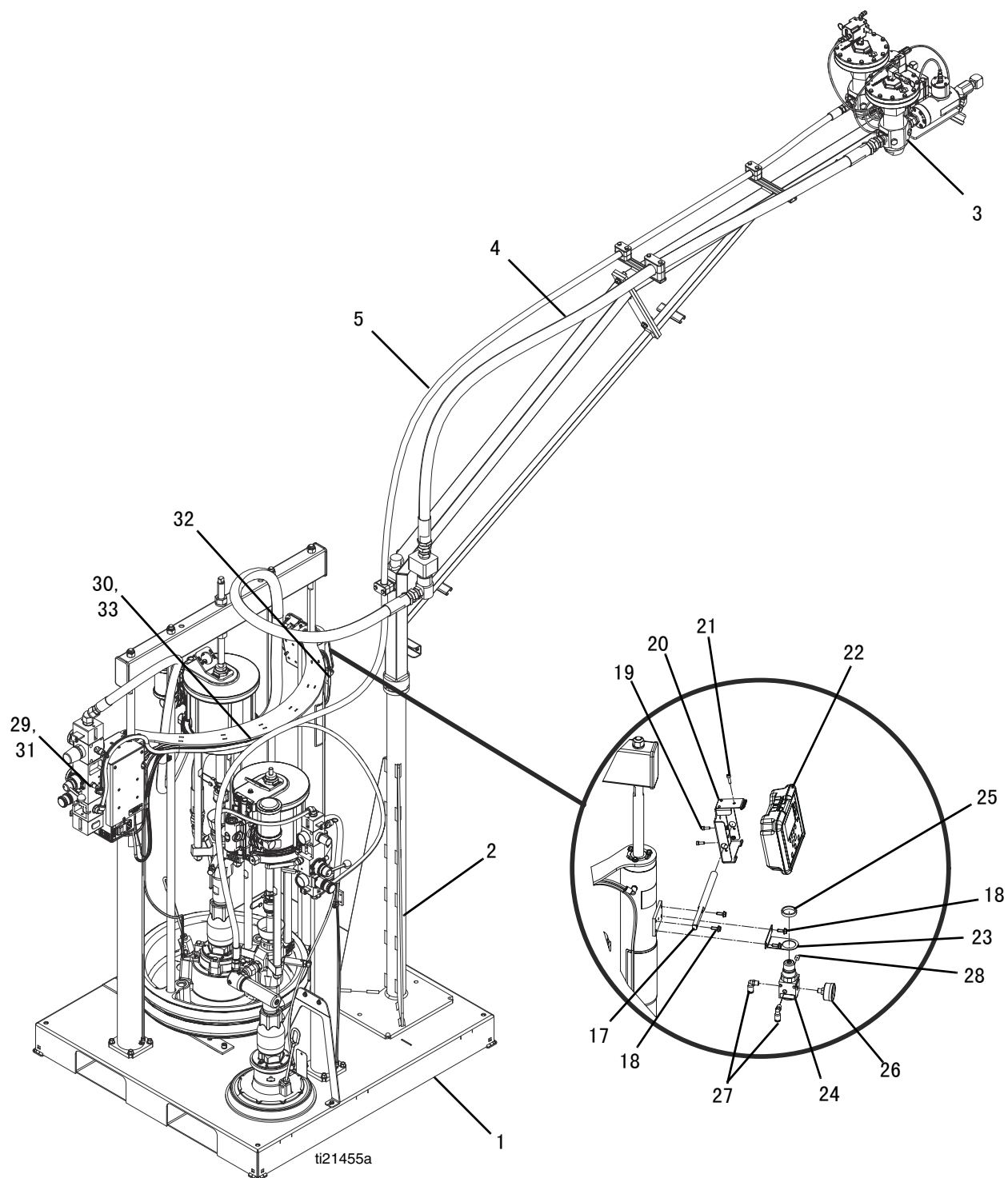
⚠ 中強度ネジ山ロッカーを塗布し、40 N?m (30 フィート-ポンド) のトルクで締めます。

2. 非旋回 NPT パイプのネジ山にパイプシーラントを塗布します。

⚠ 中強度ネジ山ロッカーを塗布し、6.9 N?m (5.1 フィート-ポンド) のトルクで締めます。

⚠ 焼け付き防止剤を塗布します。



図 2: ベース



図 3: ベース



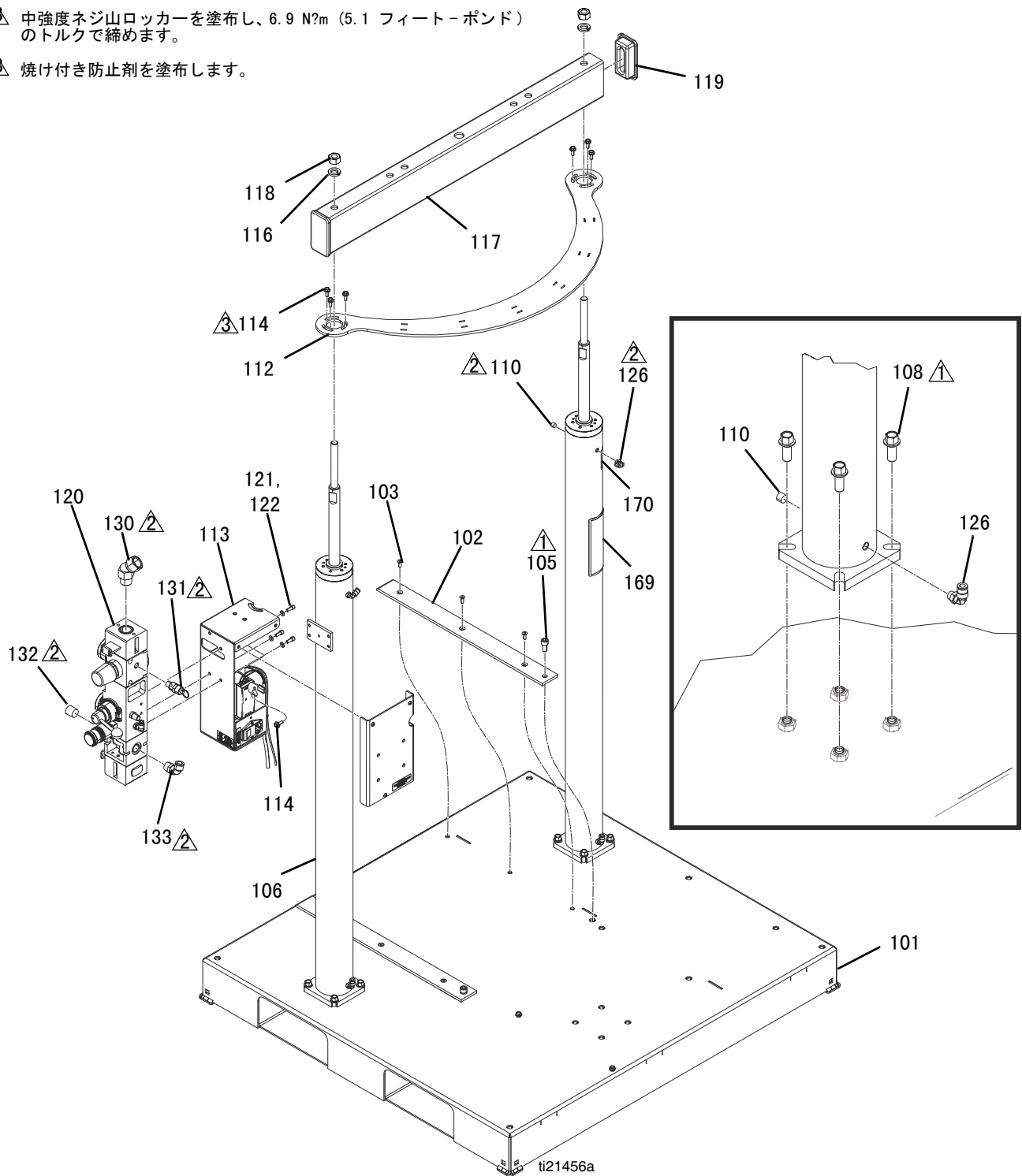

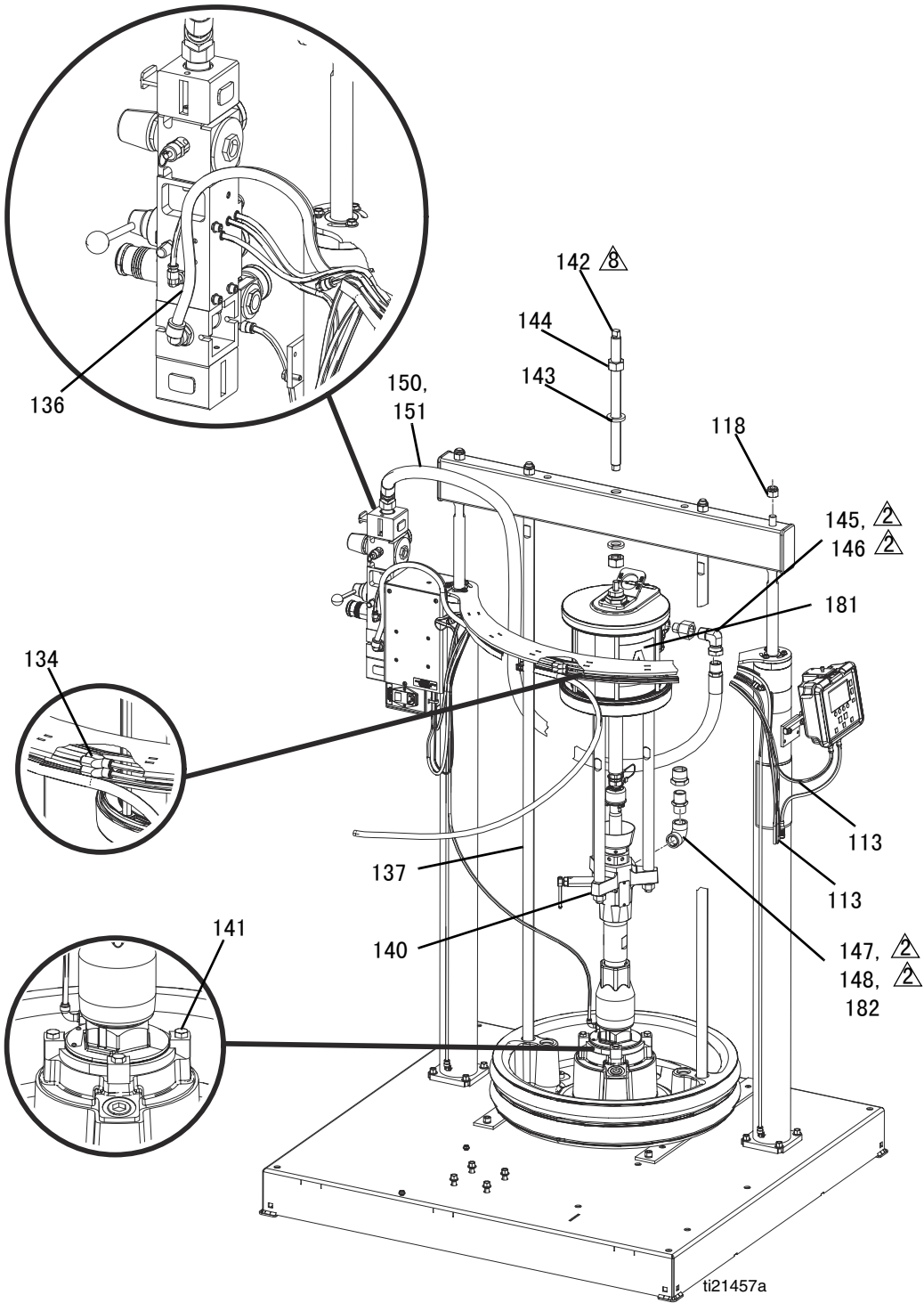

図 4: ベース

参照	部品	説明	数量
101	---	BASE, weldment, painted	1
102	16V208	GUIDE, drum	2
103	---	SCREW, machine, flathead, socket, M6-1x16mm	6
105	---	SCREW, cap, sockethead, M10-1.5x20mm	2
106	---	RAM, assembly, air cylinder	2
107	---	RAM, assembly, air cylinder, 5 gallon ram	1
108	---	SCREW, machine, hex, flange, M10-1.5x25mm	12
110	100139	PLUG, pipe	4
112	---	SUPPORT, cylinder, painted	1
113	---	MODULE, electrical	1
114	---	SCREW, machine, hex flange, M6-1x16mm	12
116	---	WASHER, lock, 5/8	4
117	---	BEAM, ram	1
118	---	NUT, hex, 5/8-11	4
119	---	CAP, end	2
120	---	CONTROL, air, ram	1
121	---	WASHER, lock, 1/4 in.	7
122	---	SCREW, cap, socket head, 1/4-20x5/8	7
126	597151	FITTING, elbow	4
130	105281	FITTING, union, swivel, 45	1
131	16P008	VALVE, safety, 75 psi	2
	116643	VALVE, safety, 90 psi (Ultra-Lite TriCore only)	2
132	100361	PLUG, pipe	1
133	15V204	FITTING, elbow, 1/2 npt x 1/2 tube	4
134	115287	FITTING, y tube	2
135	---	TUBE, nylon	39.8 ft
136	---	TUBE, polyurethane, black	6.5 ft
137	---	ROD, tie, platen, 3" ram, 55 gallon	2
138	255664	PLATE, wiper 55 gallon neoprene	1
140	---	PUMP, 61:1, saniforce <sup>?</sup> , checkmate	2
141	---	KIT, mounting, lower	1
142	---	ROD, threaded	1
143	---	WASHER, spring lock. 7/8	3
144	---	NUT, full hex, 7/8-9	3
145	104969	BUSHING, reducing	1
146	160327	FITTING, union adapter, 90 deg	1
147	112040	FITTING, elbow, 90 deg.	1
148	160032	FITTING, nipple	1
149	---	HOLDER, cable tie, rotating	1
150	G12034	HOSE, coupled 72 inch	1
151	---	SLEEVE, protective	6 ft
152	---	BRACKET, support	1
154	---	WASHER, lock spring, M8	4
155	---	BRACKET, motor mount, NXT <sup>?</sup> motors	1

参照	部品	説明	数量
157	---	PAINT, bracket, air valve	1
158	---	WASHER, lock, 3/8	2
159	---	SCREW, cap, socket head, 3/8-16x5/8	2
160	---	CONTROL, air	1
161	---	SCREW, cap, sockethead, M8-1.25x30mm	4
162	257730	PLATE, 20 liter dual wiper nitrile	1
163	---	SLEEVE, protective	3.8 ft
168	---	TAPE, electrical	1
169▲	15M511	LABEL, warning	1
170▲	15J074	LABEL, safety, crush and pinch	2
180	121150	FITTING, elbow, 1/4fnpt x 1/8mnpt	1
181	---	LABEL, a-b identification	0.500
182	---	FITTING, bushing	1

▲ 交換用の危険性と警告のラベル、タグ、カードは無料で入手できます。

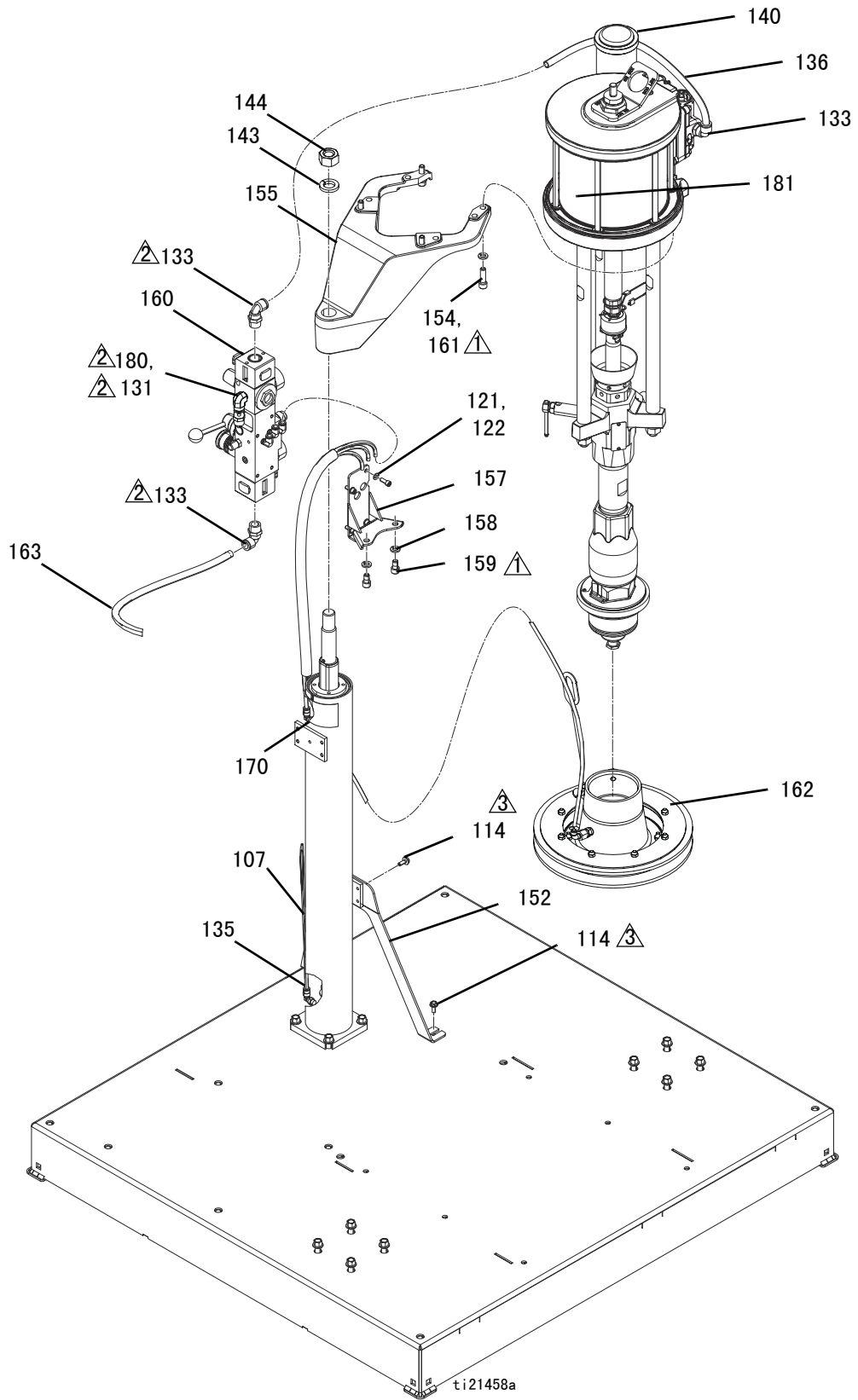
--- 別売りされていません。

### 208 リットル (55 ガロン) エアシリンダ

- ⚠ 組み立ての前に、グリースを O リングと 2 のネジ山に塗布します。
- ⚠ 2 を完全に格納された位置で取り付けます。組み立て前に、1 中にあるグリースを軸の直径に塗布します。
- ⚠ 2 の挿入前に、潤滑油をシリンダの穴に注入します。
- ⚠ 41 N?m (30 フィート-ポンド) のトルクで締めます。
- ⚠ グリースを O リングに塗布します。



図 5: 208 リットル (55 ガロン) エアシリンダ

参照	部品	説明	数量
201	---	ラム、チューブ、アセンブリ	1
202	---	PISTON, rod, assembly	1
202.1	---	CAP, bearing, air cylinder	1
202.2◆	---	BEARING, air cylinder	1
202.3◆	---	RING, retaining, spiral	1
202.4◆	---	PACKING, o-ring, 214	1
202.5	16V078	SHAFT, piston, air cylinder	1
202.6◆	---	PACKING, o-ring, buna-n	2
202.7	183943	PISTON	1
202.8◆	---	GUIDE, spring	1
202.9◆	---	PACKING, o-ring	1
202.10◆	---	WASHER, plain, 5/8	1
202.11◆	---	NUT, hex, 5/8-11	1
202.12◆	---	SPRING, compression	1
202.14◆	---	WASHER, lock, 5/8	1

◆ 部品はキット 24T006 にあります。

--- 別売りされていません。

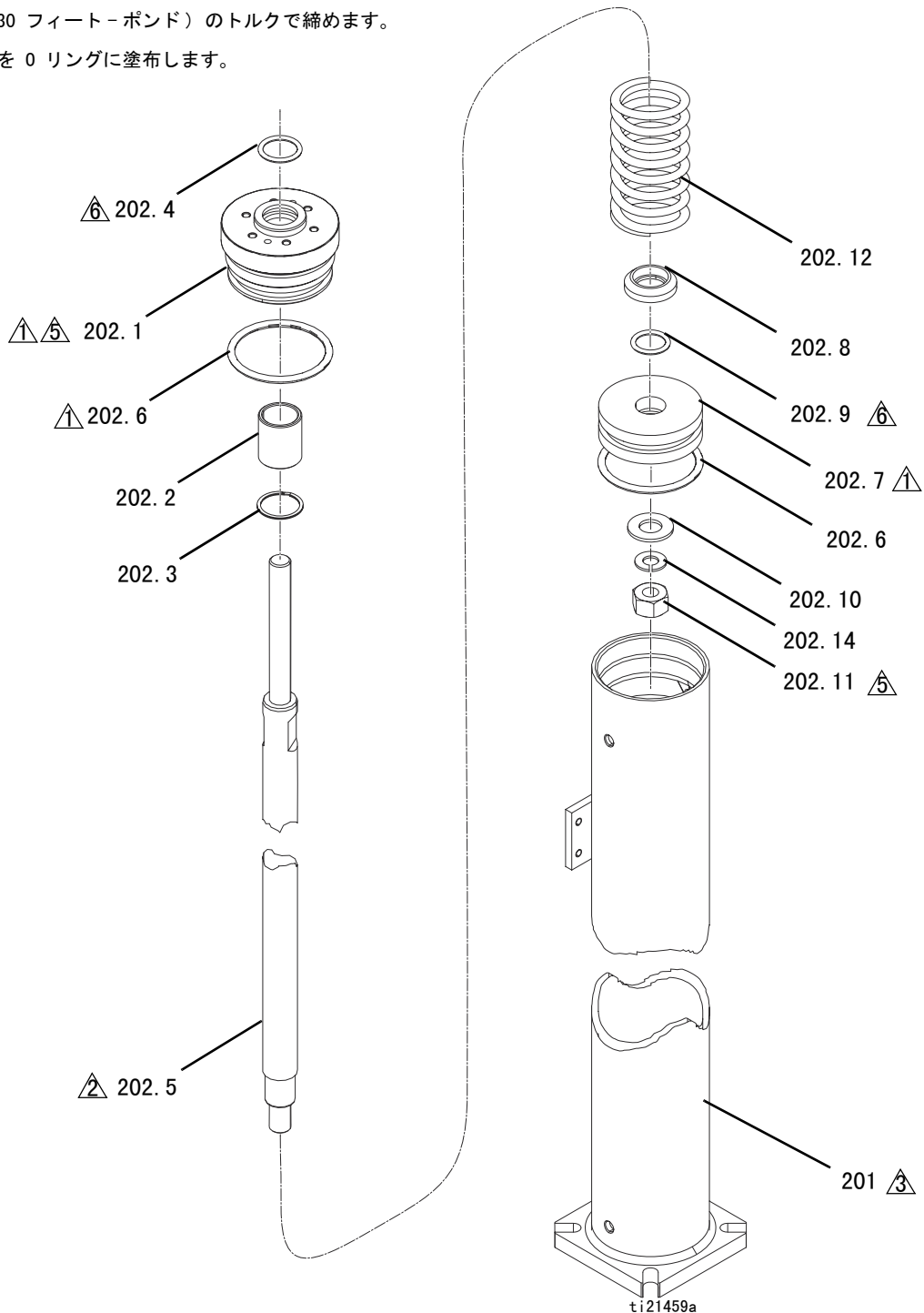
### 18.9 リットル (5 ガロン) エアシリンダ

- ▲ 組み立ての前に、グリースを 0 リングと 2 のネジ山に塗布します。
- ▲ 2 の挿入前に、グリースをシリンダの穴に注入します。
- ▲ 2 を完全に格納された位置で取り付けます。組み立て前に、1 の中にあるグリースを軸の直径に塗布します。
- ▲ パイプシーラントをテーパーパイプのネジ山に塗布します。
- ▲ グリースをシールと軸受の表面に塗布します。
- ▲ 中強度ネジ山ロッカーをネジ山に塗布し、ナットを 41 N<sup>2</sup>m (30 フィートポンド) のトルクで締めます。



図 6: 18.9 リットル (5 ガロン) エアシリンダ

参照	部品	説明	数量
301	---	RAM, tube, 5 gallon ram, assembly	1
302	---	PISTON, rod, 5 gallon ram, assembly	1
302.1	16V170	SHAFT, piston, air cylinder, 5 gallon ram	1
302.2	---	BEARING, rod top	1
302.3	15U979	PIN, spring, straight	3
302.4◆	---	PACKING, o-ring, buna-n	2
302.5◆	---	SEAL, D-shaped ucup	1
302.6	183943	PISTON	1
302.7◆	---	NUT, hex, 5/8-11	1
302.8◆	---	WASHER, plain, 5/8	1
302.9◆	---	PACKING, o-ring	1
302.10◆	---	BEARING, ram end cap	1
302.11◆	---	RETAINER, retaining ring, 1.88 bore	1
302.12◆	---	SPRING, compression	1
302.15◆	15U006	SPACER, D-seal backup ring	1
302.16◆	---	WASHER, lock, 5/8	1
303	---	RING, retaining, 3.06 diameter	1
307	597151	FITTING, elbow	2

◆ 部品はキット 24T007 にあります。

--- 別売りされていません。

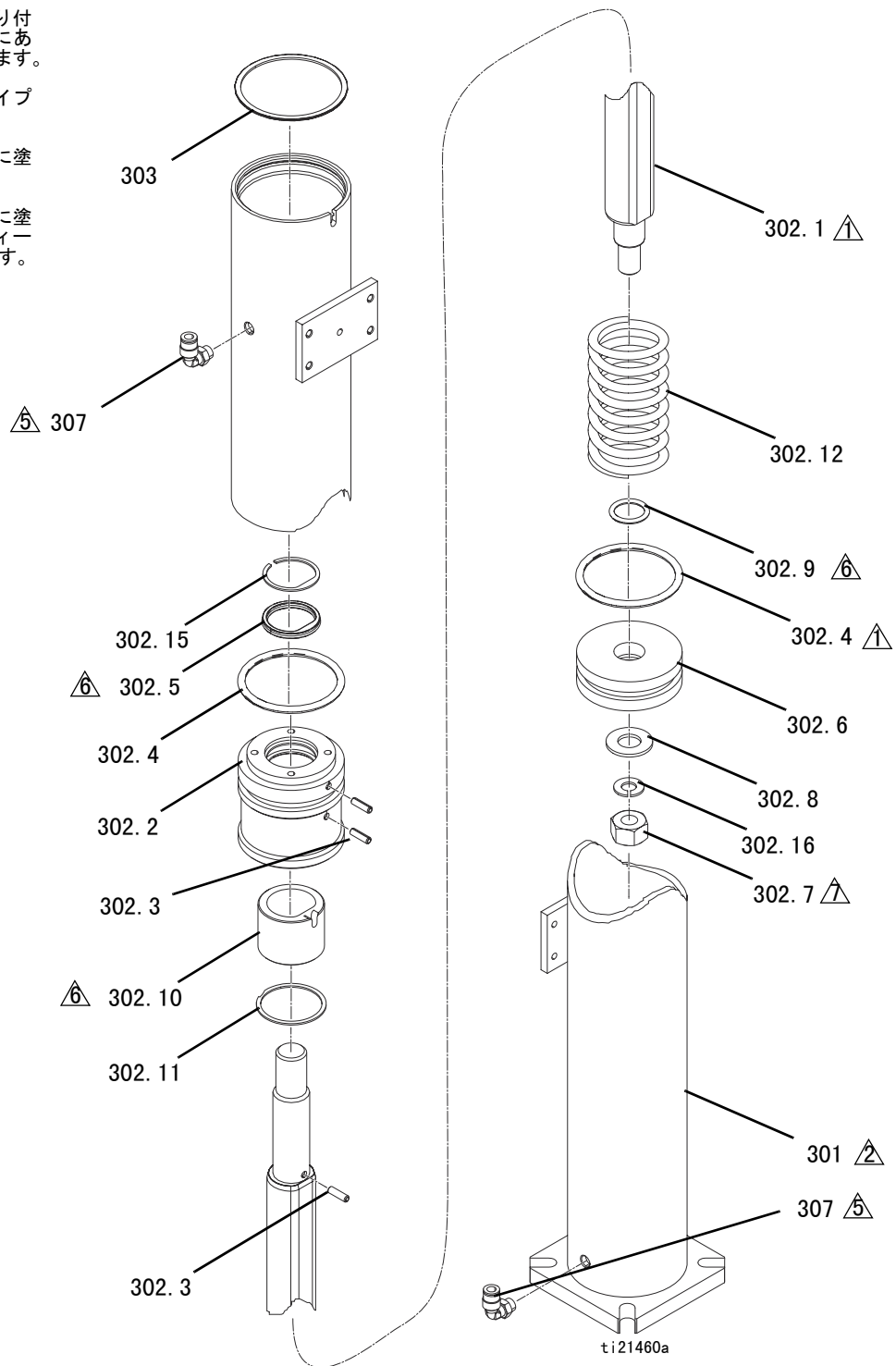
電気エンクロージャ



図 7: 電気エンクロージャ



参照	部品	説明	数量
1702	121598	CORD, power, v-lock	1
1703	---	COVER, enclosure	1
1704	---	BRACKET, mounting	1
1705▲	186620	LABEL, symbol, ground	1
1706	---	HARNESS, 16ga, green/yellow	1
1707	---	BULKHEAD, enclosure	1
1708	---	SCREW, flathead, M3-0.5x10mm	2
1709	120910	SOCKET, electrical, with EMI filter	1
1710	---	SCREW, button head, M5-0.8x10mm, ss	5
1711	126453	POWER SUPPLY, 24v	1
1712	---	LABEL, identification	1
1713	---	RAIL, mount	0.3 ft
1716	---	WASHER, lock, external, M5	3
1718	---	HARNESS, 16ga, black,	2
1719	---	HARNESS, 16ga, green/yellow	2
1720	---	HARNESS, 16ga, green/yellow,	1
1721	16U012	HARNESS, CAN, M12	1
1724	---	BRACKET, switch	1
1734	---	NUT, hex, M5-0.8	7
1735	---	WASHER, plain, #10	4
1736	114835	FUSE, 4.0 amp, 250v, time lag	2
1737	---	GUARD, trim, edge	1
1738	---	LABEL	1

▲ 交換用の危険性と警告のラベル、タグ、カードは無料で入手できます。

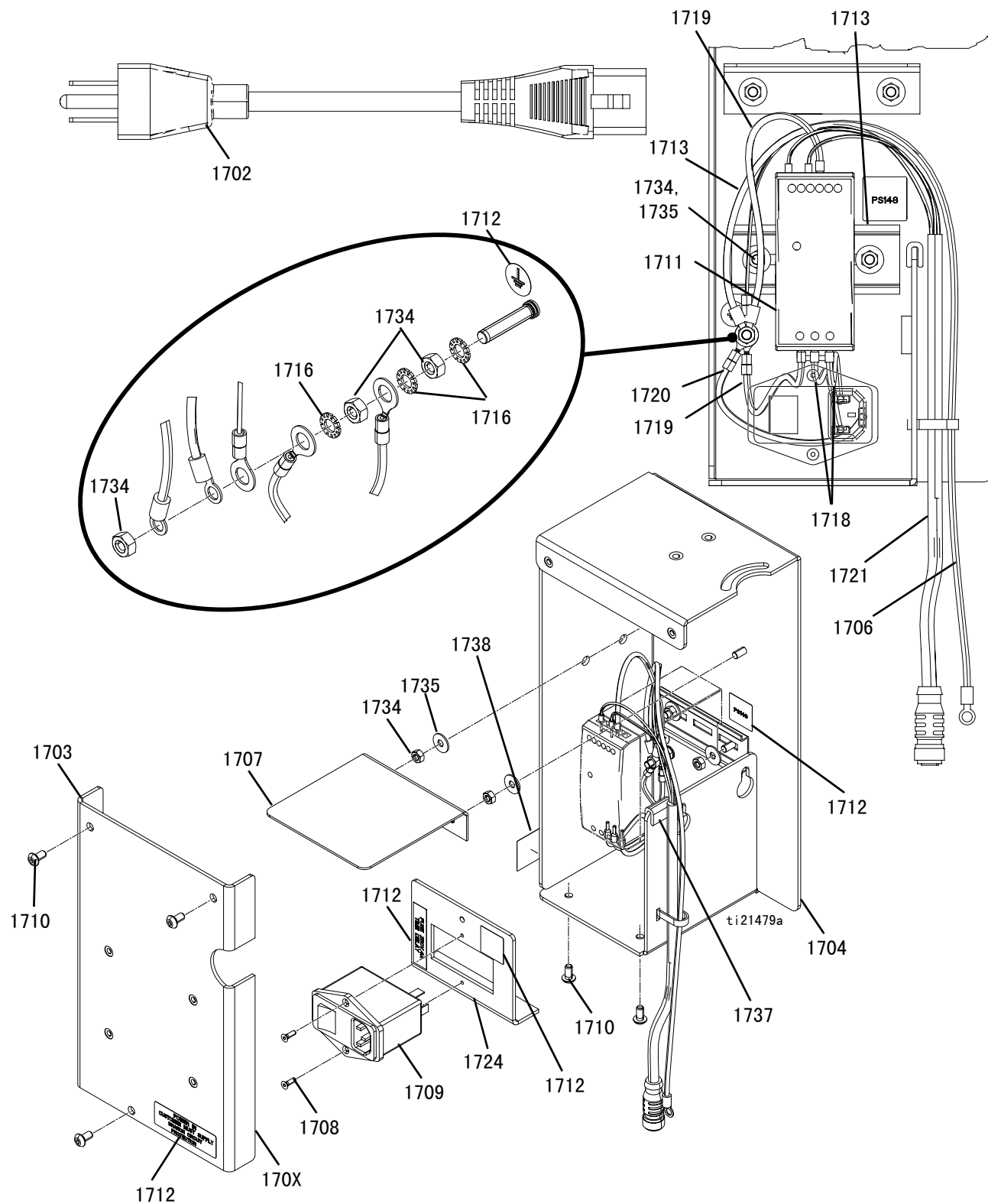
--- 別売りされていません。

### Checkmate ポンプ

△1 68-81 N?m (50-60 フィート-ポンド) のトルクで締めます。

△2 中強度ネジ山ロックをネジ山に塗布し、196-210 N?m (124-155 フィート-ポンド) のトルクで締めます。

△3 パイプシーラントを塗布します。

△4 焼け付き防止剤を塗布します。



図 8: Checkmate ポンプ

参照	部品	説明	数量
401❖	24R015	MOTOR, assembly, air, 7.5 inch, blue	1
402	257360	ROD, tie, NXT to lower	3
403❖	L100CS	LOWER, 100 Severe Duty <sup>?</sup>	1
404	---	WASHER, lock, spring, #16	3
405	---	NUT, machine, hex, M16-2	3
406	15H392	ROD, adapter xtreme <sup>?</sup>	1
407	244819	COUPLING, assembly	1
408	197340	COVER, coupler	1
409	244820	CLIP, hairpin (w/ lanyard)	1
410	117237	MUFFLER	1
411	100896	FITTING, bushing, pipe	1
412	115764	FITTING, elbow, 90	1
413	15J993	RING, lift, plate	1
414	---	NUT, jam, hex, 1.5-12	1
419	---	LABEL, identification	1
421	112887	WRENCH, spanner	1

❖ 詳細については、特定の構成部品の取扱説明書を参照してください。

## ブームアセンブリ

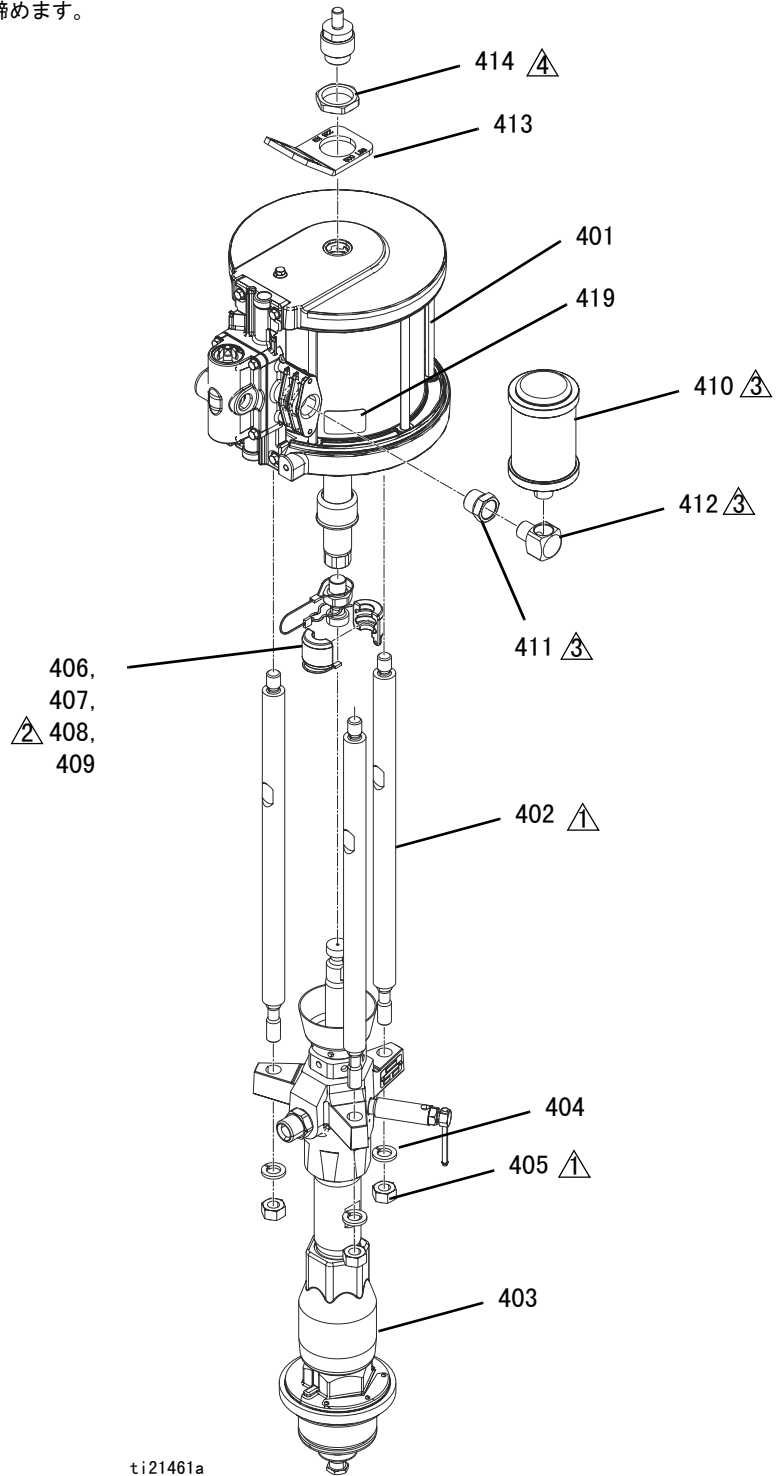
⚠ 中強度ネジ山ロッカーをネジ山に塗布し、41 N?m  
(30 フィート・ポンド) のトルクで締めます。



図 9: ブームアセンブリ

参照	部品	説明	数量
501	---	SUPPORT, mast	1
502	---	BEARING, support, boom mast	1
503	---	SUPPORT, boom, weldment, bearing	1
504	---	ARM, boom, upper, painted	1
505	---	SCREW, cap, hex, serrated, M10-1.5x30mm	3
507	---	PLUG, tube	1
508	---	SCREW, machine, hex, flange, M10-1.5x25mm	4
509	---	NUT, hex, flange, serrated, M10-1.5	3
510	U5A008	CLAMP, hose, 1" id	1
511	123100	CLAMP, hose, boom, 7/8"	3
512	---	COVER, plate	3
515	---	SCREW, cap, hex, 1/4-20x1.75	6
516	---	NUT, rail	6
518▲	15H108	LABEL, pinch point	1

▲ 交換用の危険性と警告のラベル、タグ、カードは無料で入手できます。

--- 別売りされていません。

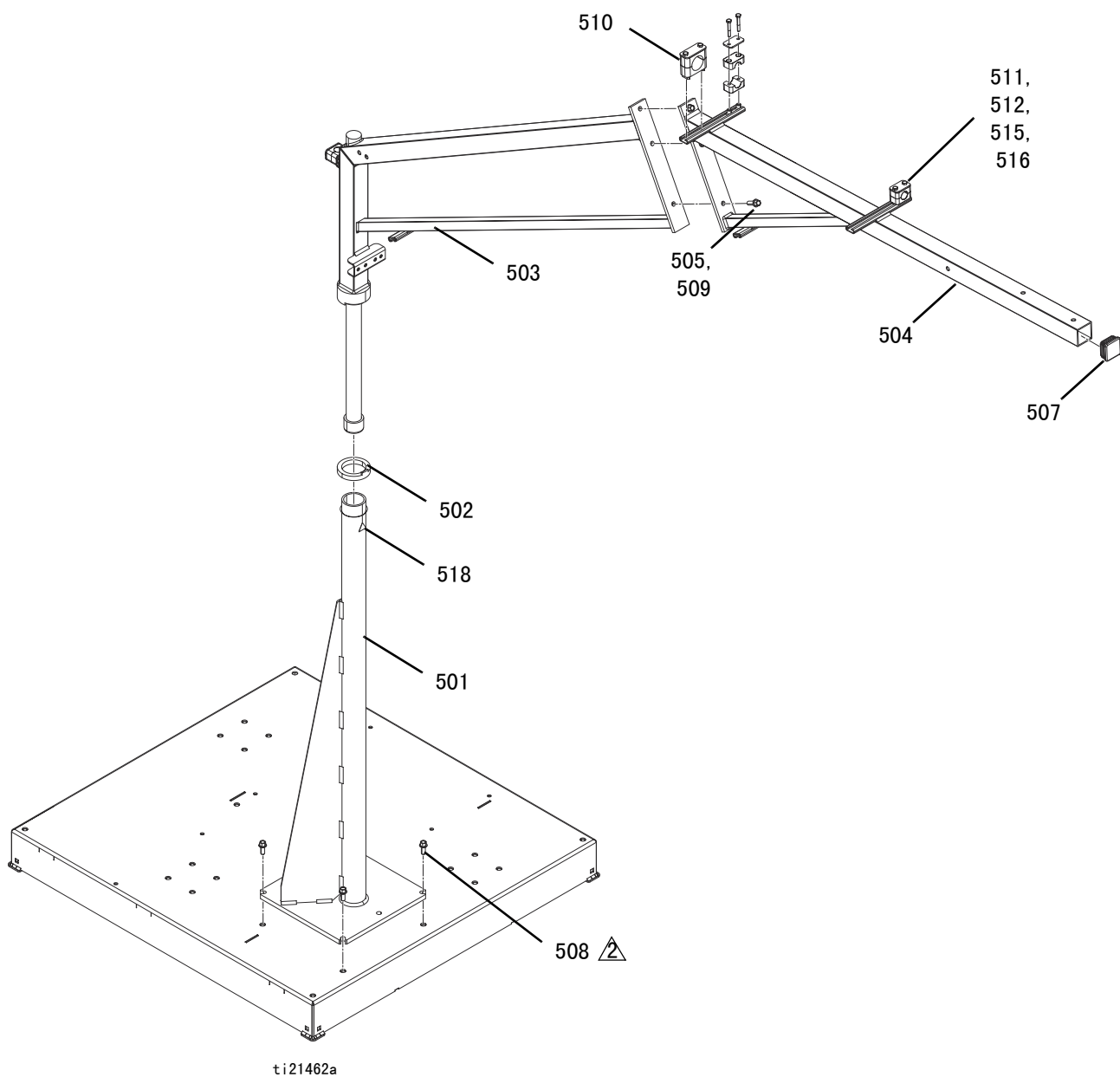
## 液体プレート

⚠ 必要に応じてすべての雄ネジにパイプシーラントを塗布します。



図 10: 液体プレート

参照	部品	説明	数量
601	---	PLATE, mounting, meter, regulator	1
602❖	289814	METER, gear, assembly	1
603❖	246652	METER, heli gear, hi resolution	1
604	15R873	FITTING, tee	1
605	160032	FITTING, nipple	2
606	157785	FITTING, swivel	1
607❖	246642	REGULATOR, mastic	2
608	162449	FITTING, nipple, reducing	1
609	121282	FITTING, swivel, straight	1
610	116504	FITTING, tee, run	1
611◆	---	MODULE, GCA, cube, base	1
612◆	---	MODULE, GCA, cube, FCM	1
613	---	HOLDER, anchor, wire tie	2
614	103656	FITTING, pipe, hex	3
615	24R938	REGULATOR, electro/pneumatic	1
616	126996	HARNESS, m8xm12	1
617	126520	CONNECTOR, splitter	1
618	122030	CABLE, GCA	1
619	16U014	HARNESS, 5px3p	1
621	---	SCREW, machine, hex flange, M6-1x10mm	4
622	---	SCREW, cap, socket head, M4-0.7x16mm	4
623	---	SCREW, button head, M5-0.8x25mm	1
624	---	WASHER, lock, external, M5	4
625	---	NUT, hex, M5-0.8	2
626	16U132	HARNESS, FCM, ground	1
627	112698	ELBOW, male, swivel	2
628	127032	VALVE, power	1
629	512909	MUFFLER, polyethylene	1
630	123395	HARNESS, power valve, tank	1
631	158586	FITTING, bushing	1
632	196142	FITTING, adapter 1/2 npt x 3/4 npt	1
633	---	SCREW, button head, M5-0.8x10mm, sst	2
634	---	SCREW, machine, pan wash head, M4-0.7x8mm	1
635	---	SCREW, sockethead, M10-1.5x75mm, sst	2
636	---	NUT, hex, flange, serrated, M10-1.5	2
639	100206	BUSHING, pipe	1
640	113654	GAUGE, pressure, fluid, sst	2
641	159840	ADAPTER	2
642	100896	FITTING, bushing, pipe	1
644	125497	FITTING, tee, 1/8 nptf, female	1
645	116643	VALVE, safety, relief, air	2
646▲	16V630	LABEL, identification	1
648	277674	ENCLOSURE, cube door	1
649	121283	FITTING, elbow, 45 degree street	2
650	118137	FITTING, elbow 90 degree	1
651	158683	FITTING, elbow, 90 degree	1

▲ 交換用の危険性と警告のラベル、タグ、カードは無料で入手できます。

❖ 詳細については、特定の構成部品の取扱説明書を参照してください。

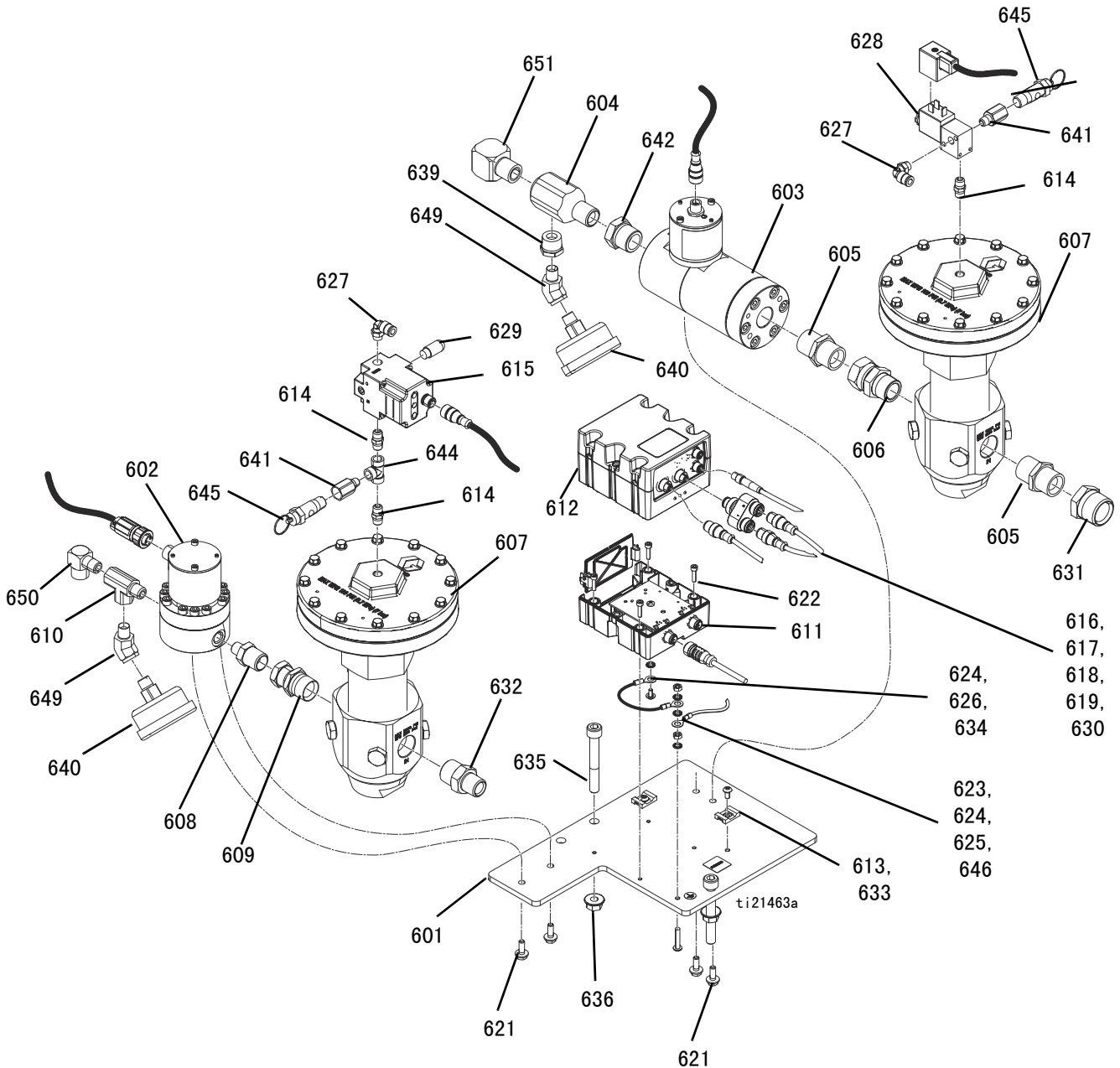
◆ 部品はキット 24T002 にあります。

--- 別売りされていません。

24R662 - 多量ホース

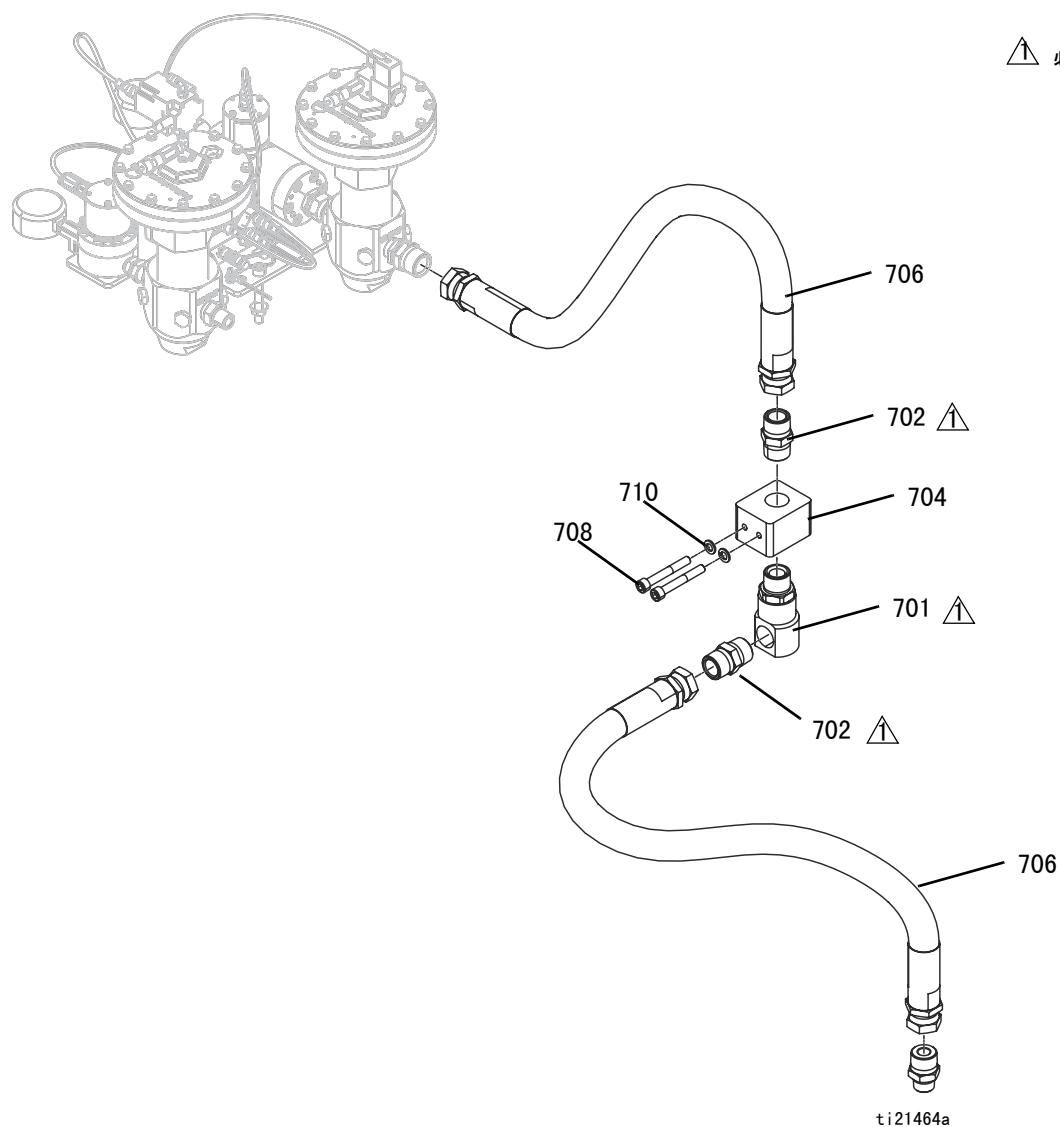

⚠ 必要に応じてパイプシーラントを使用します。

図 11: 多量ホース

参照	部品	説明	数量
701	127025	FITTING, elbow, swivel, 1" npt	1
702	C38302	FITTING, nipple, 1" npt	2
703	C38304	FITTING, nipple, 1" x 3/4 npt	1
704	---	MANIFOLD, block, boom	1
706	16V239	HOSE, assembly	2
708	---	SCREW, shcs, M10-1.5x75mm, sst	2
710	---	WASHER, lock, M10	2



24R663 - 少量ホース

⚠ 必要に応じてすべての雄ネジにパイプシーラントを塗布します。

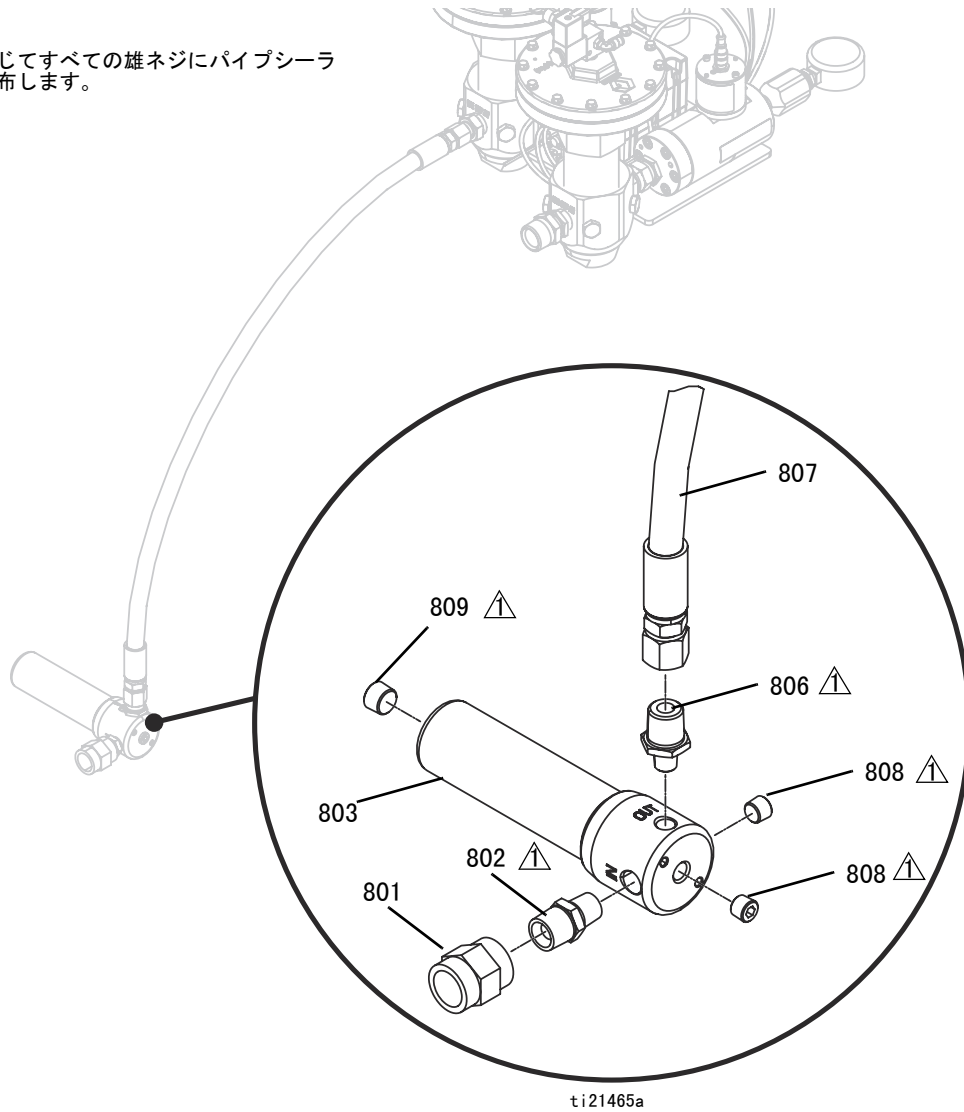

ti21465a

図 12: 少量ホース

参照	部品	説明	数量
801	158556	COUPLING, hex pipe	1
802	159239	FITTING, nipple, pipe, reducing	1
803	218029	FILTER, fluid	1
806	162449	FITTING, nipple, reducing	1
807	16V222	HOSE, assembly, 1/2" x180"	1
808	100721	PLUG, pipe	2
809	101754	PLUG, pipe	1

# ホースキット



図 13: ホースキット

参照	部品	説明	数量					
			24R832	24R833	24R834	24T092	24T093	24T094
901	24R805	HOSE, assembly, dispenser, low volume	1					
	24R806	HOSE, assembly, dispenser, low volume		1				
	24R822	HOSE, assembly, dispenser, low volume			1			
	24T086	HOSE, assembly, dispenser, low volume				1		
	24T087	HOSE, assembly, dispenser, low volume					1	
	24T088	HOSE, assembly, dispenser, low volume						1
902	24R734	HOSE, assembly, dispenser, high volume	1	1	1	1	1	1

24R805, 24R806, 24R822, 24T092, 24T093, 24T094 - 少量ホースキット

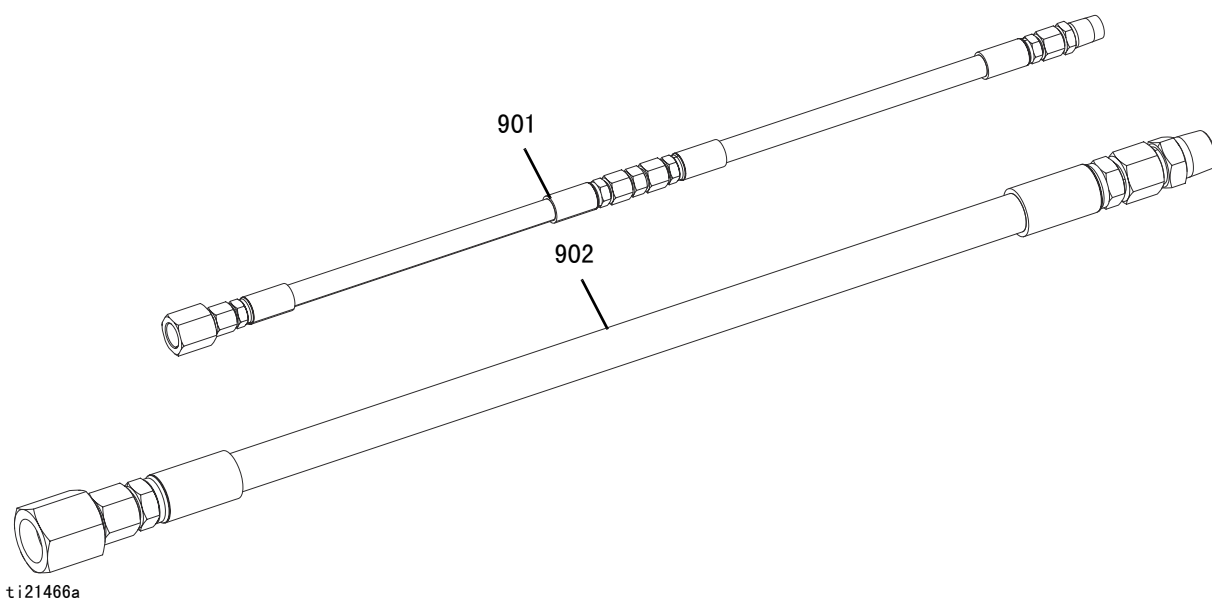

図 14: 少量ホースキット

参照	部品	説明	数量					
			24R805	24R806	24R822	24T086	24T087	24T088
1001	124961	FITTING, adapter, 04jicx1/4npt	1	1	1		1	
	116704	ADAPTER, 9/16-18jic x 1/4npt				1		
	116703	ADAPTER, 3/4-16jic x 1/4npt						1
1002	16V219	HOSE, assembly, 1/4" x60"		1	1			
	16V531	HOSE, assembly, 1/8" x60"	1				1	
	16V220	HOSE, assembly, 3/8" x60"				1		
	16V221	HOSE, assembly, 1/2" x60"						1
1004	123251	FITTING, union, jic04	1	1	1		1	
	124852	ADAPTER, jic04 x jic06				1		
	126366	FITTING, union, jic08 x jic06						1
1006	16V531	HOSE, assembly, 1/8" x60"	1	1				
	16V219	HOSE, assembly, 1/4" x60"			1	1		
	16W047	HOSE, assembly, 3/32" x60"					1	
	16V220	HOSE, assembly, 3/8" x60"						1
1007	127093	FITTING, adapter, 1/4npt x jic04	1	1	1	1	1	
	124967	FITTING, adapter, jic06 x 1/4npt						1

24R734 - 多量ホース

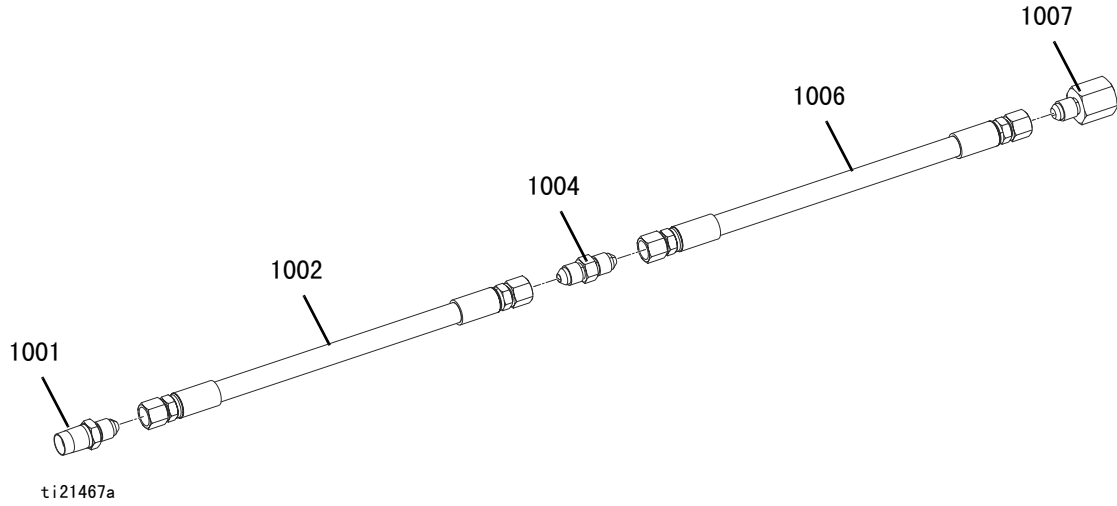

図 15: 多量ホース

参照	部品	説明	数量
1201	126976	FITTING, adapter, 1/2nptf x 10jicm	1
1202	C20768	FITTING, straight	1
1203	16V311	HOSE, assembly, 5/8" x120"	1

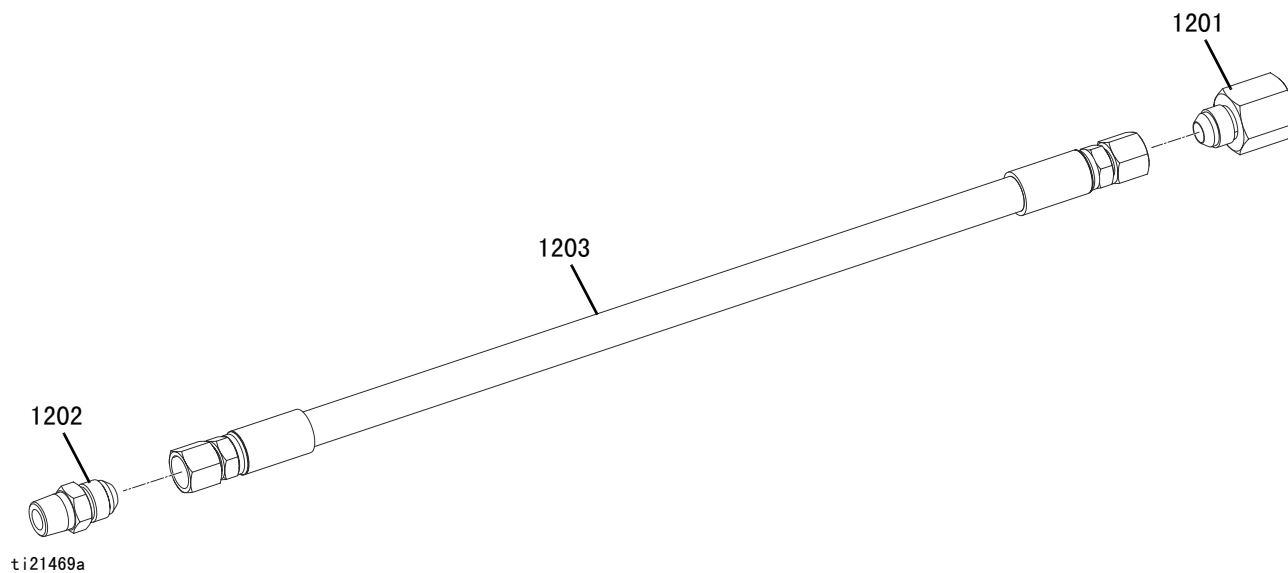

# ディスペンサルブ

## 24P221 - Ultra-Lite<sup>?</sup> TriCore

△ 必要に応じてすべての雄ネジにパイプシーラントを塗布します。



図 16: Ultra-Lite TriCore

参照	部品	説明	数量
1301	512135	NOZZLE, extrusion	6
1302❖	235628	GUN, flow, ultra-lite 6000	1
1303	207947	SWIVEL, straight, 1/2nptf x 1/2nptm	1
1304	24R682	MIXER, tri-core, high flow	1
	948081	MIXER, tri-core, low flow	1
1305	623875	MANIFOLD, mix	1
1306	127049	VALVE, check, 1/4npt	1
1307	196142	FITTING, adapter 1/2 npt x 3/4 npt	1
1308	159239	FITTING, nipple, pipe	2
1309	155570	SWIVEL, union	1
1310	100721	PLUG, pipe	1
1311	214037	VALVE, ball	1
1313	624157	HOUSING, injector 1/4 npt	1
1314★	116643	VALVE, safety, relief, air	2

❖ 詳細については、特定の構成部品の取扱説明書を参照してください。

★ 図示せず。

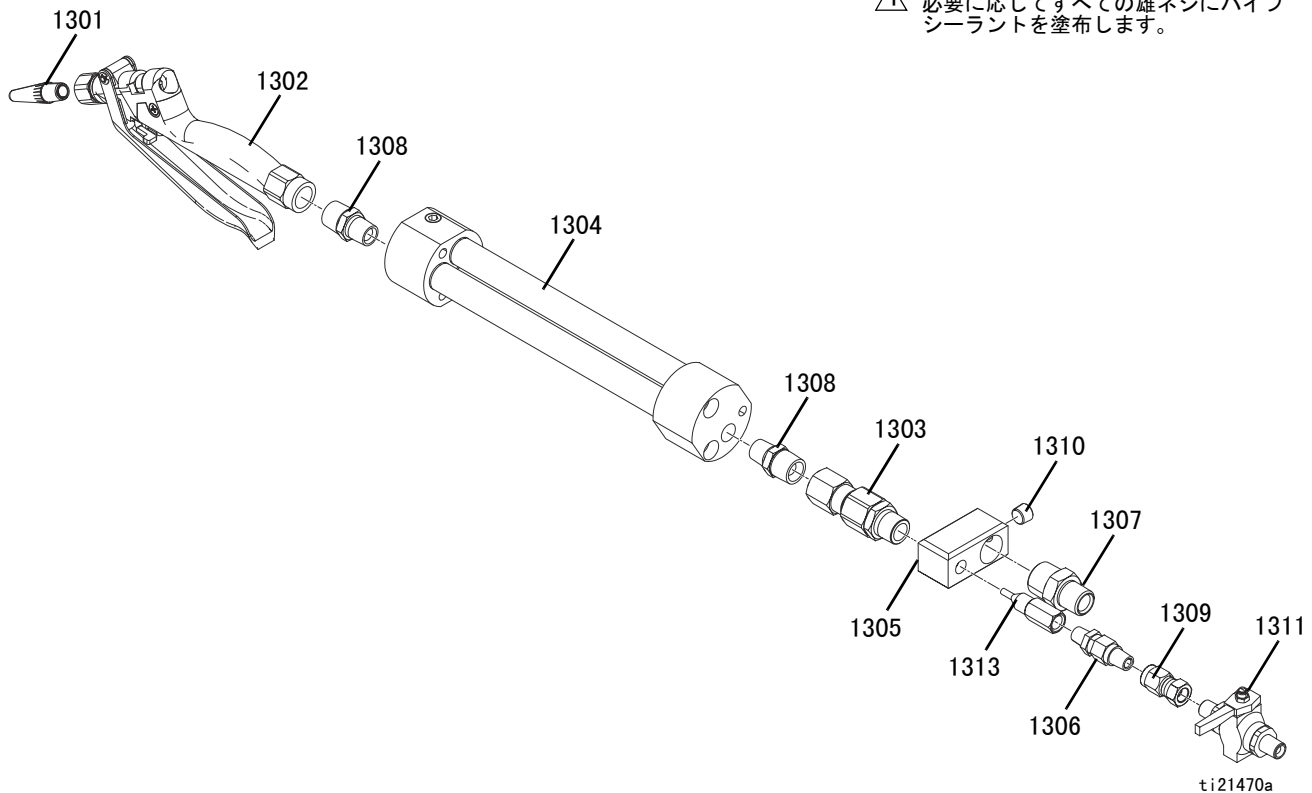
24R682 - Tri-Core ミキサー

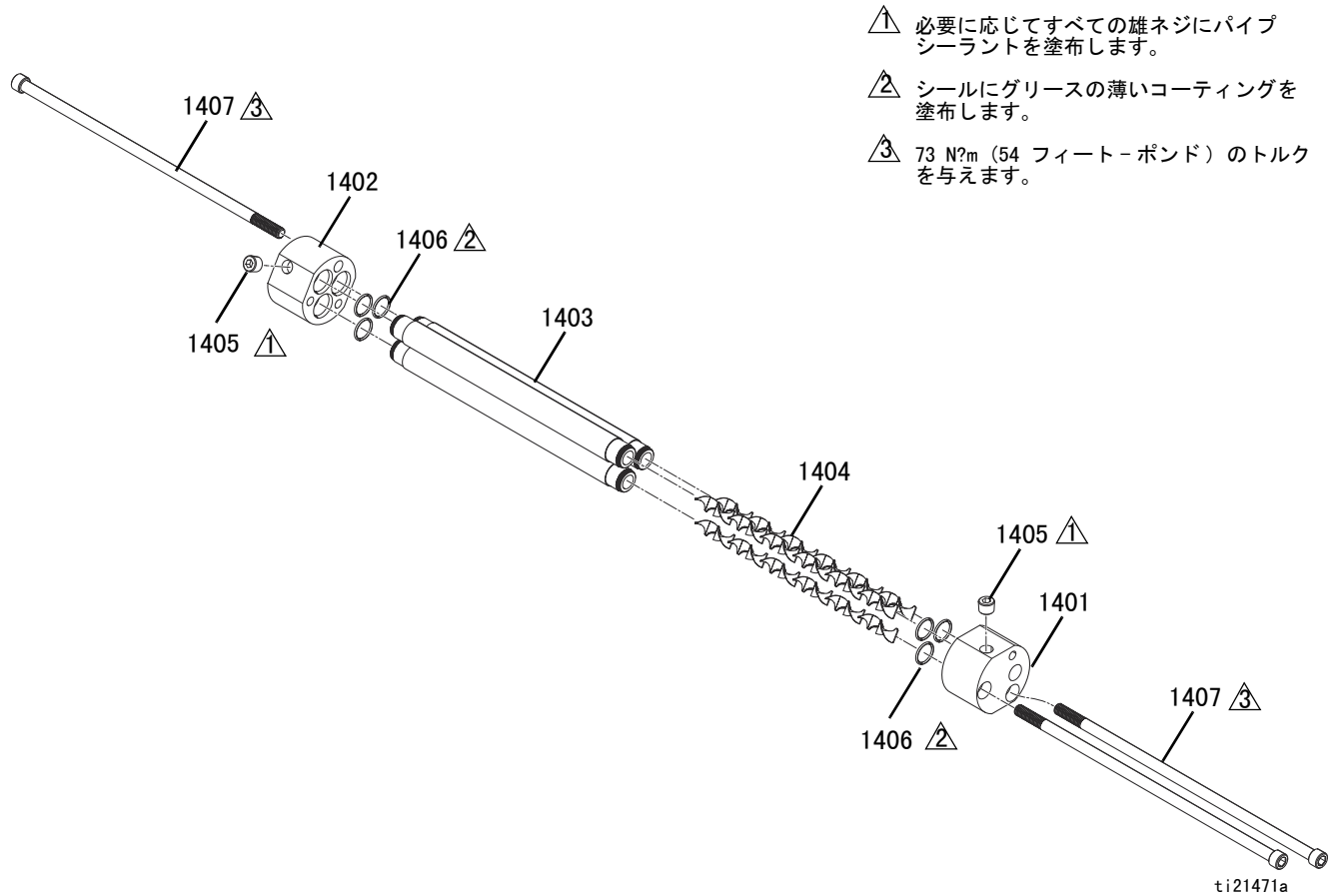

- ⚠ 1 必要に応じてすべての雄ネジにパイプシーラントを塗布します。
- ⚠ 2 シールにグリースの薄いコーティングを塗布します。
- ⚠ 3 73 N<sup>2</sup>m (54 フィート-ポンド) のトルクを与えます。

図 17: Tri-Core ミキサー

参照	部品	説明	数量
1401	16V145	CAP, end, mixer, tri-core, inlet	1
1402	16V146	CAP, end, mixer, tri-core, outlet	1
1403	16V448	TUBE, crossover, tri-core	3
1404	127083	MIXER, static, 0.494dia x 12el, ss	3
1405	100721	PLUG, pipe	2
1406	111116	PACKING, o-ring, seat	6
1407	127081	SCREW, sockethead, 3/8-16x12 in.	3

24P223 - Ultra-Lite

△ 必要に応じてすべての雄ネジにパイプシーラントを塗布します。



図 18: Ultra-Lite

参照	部品	説明	数量
1501	512135	NOZZLE, extrusion	6
1502❖	235628	GUN, flow, ultra-lite 6000	1
1503	207947	SWIVEL, straight, 1/2nptf x 1/2nptm	1
1504	948097	MIXER, hose, 36 element	1
	948315	OPTIONAL - MIXER, hose, 24element	1
1505	623875	MANIFOLD, mix	1
1506	195898	VALVE, check, 1/4 npt (m)	1
1507	155570	SWIVEL, union	1
1508	196142	FITTING, adapter 1/2 npt x 3/4 npt	1
1509	214037	VALVE, ball	1
1510	100721	PLUG, pipe	1
1512	624157	HOUSING, injector 1/4 npt	1

❖ 詳細については、特定の構成部品の取扱説明書を参照してください。

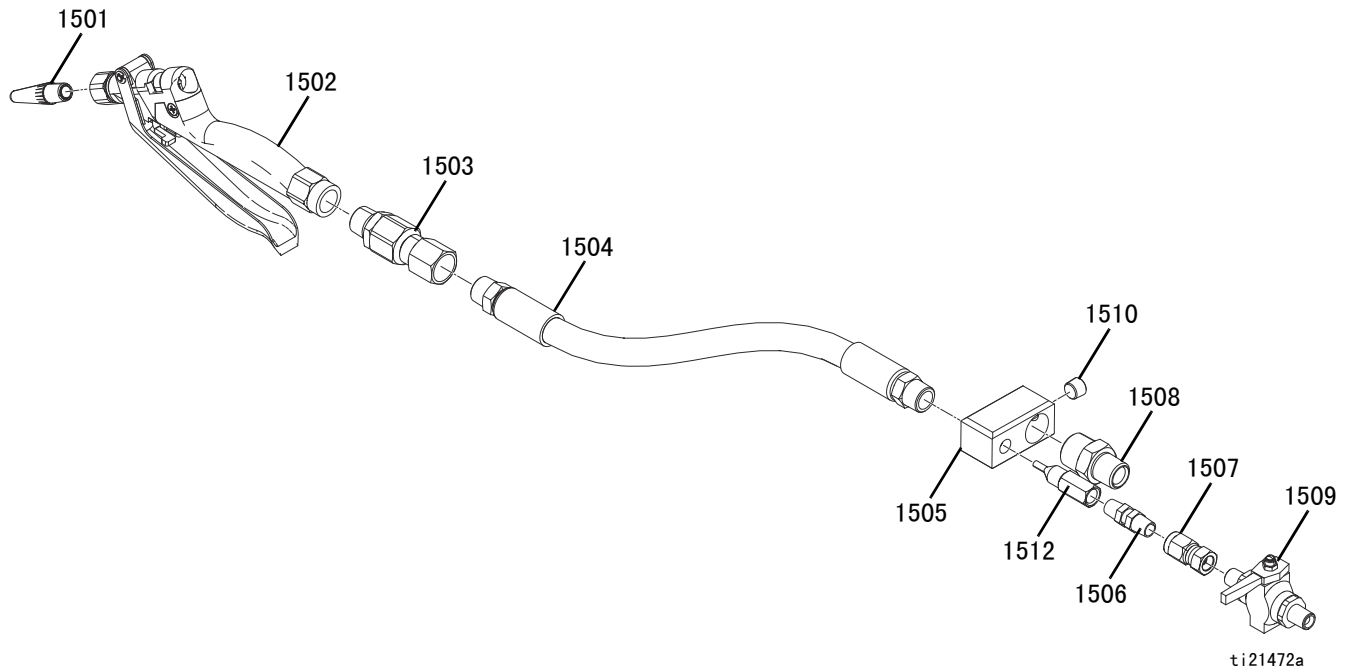

24P217 - MD2

⚠ 必要に応じてすべての雄ネジにパイプシーラントを塗布します。



図 19: MD2

参照	部品	説明	数量
1601❖	255182	VALVE, dispense, 10:1, hard seats	1
1602	255206	HANDLE, 2k dispense valve, air	1
1603	159239	FITTING, nipple, pipe	1
1604	207947	SWIVEL, straight, 1/2nptf x 1/2nptm	1
1605	127104	FITTING, elbow, 3/8nptxsae06	1
1607	122969	FITTING, elbow, 1/4nptxsae06	1
1608	104765	PLUG, pipe headless	2
1610	15W744	SLEEVE, protective	30
1611	C12509	TUBE, nylon	30
1612	155570	SWIVEL, union	1
1613	214037	VALVE, ball	1
1614	195898	VALVE, check, 1/4 npt (m)	1
1615	189018	SWIVEL	1
1616	125428	FITTING, connector, male, 1/4 nptf	1

❖ 詳細については、特定の構成部品の取扱説明書を参照してください。

# Graco Standard Warranty

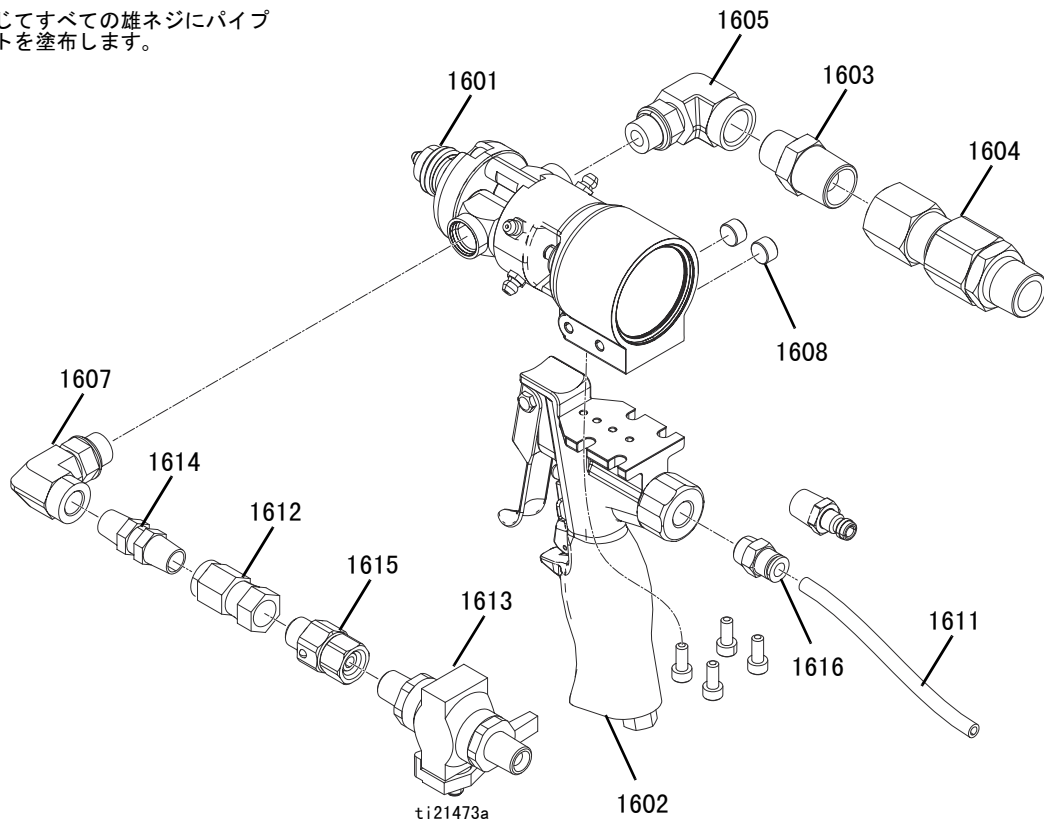
Graco warrants all equipment referenced in this document which is manufactured by Graco and bearing its name to be free from defects in material and workmanship on the date of sale to the original purchaser for use. With the exception of any special, extended, or limited warranty published by Graco, Graco will, for a period of twelve months from the date of sale, repair or replace any part of the equipment determined by Graco to be defective. This warranty applies only when the equipment is installed, operated and maintained in accordance with Graco's written recommendations.

This warranty does not cover, and Graco shall not be liable for general wear and tear, or any malfunction, damage or wear caused by faulty installation, misapplication, abrasion, corrosion, inadequate or improper maintenance, negligence, accident, tampering, or substitution of non-Graco component parts. Nor shall Graco be liable for malfunction, damage or wear caused by the incompatibility of Graco equipment with structures, accessories, equipment or materials not supplied by Graco, or the improper design, manufacture, installation, operation or maintenance of structures, accessories, equipment or materials not supplied by Graco.

This warranty is conditioned upon the prepaid return of the equipment claimed to be defective to an authorized Graco distributor for verification of the claimed defect. If the claimed defect is verified, Graco will repair or replace free of charge any defective parts. The equipment will be returned to the original purchaser transportation prepaid. If inspection of the equipment does not disclose any defect in material or workmanship, repairs will be made at a reasonable charge, which charges may include the costs of parts, labor, and transportation.

**THIS WARRANTY IS EXCLUSIVE, AND IS IN LIEU OF ANY OTHER WARRANTIES, EXPRESS OR IMPLIED, INCLUDING BUT NOT LIMITED TO WARRANTY OF MERCHANTABILITY OR WARRANTY OF FITNESS FOR A PARTICULAR PURPOSE.**

Graco's sole obligation and buyer's sole remedy for any breach of warranty shall be as set forth above. The buyer agrees that no other remedy (including, but not limited to, incidental or consequential damages for lost profits, lost sales, injury to person or property, or any other incidental or consequential loss) shall be available. Any action for breach of warranty must be brought within two (2) years of the date of sale.

**GRACO MAKES NO WARRANTY, AND DISCLAIMS ALL IMPLIED WARRANTIES OF MERCHANTABILITY AND FITNESS FOR A PARTICULAR PURPOSE, IN CONNECTION WITH ACCESSORIES, EQUIPMENT, MATERIALS OR COMPONENTS SOLD BUT NOT MANUFACTURED BY GRACO.** These items sold, but not manufactured by Graco (such as electric motors, switches, hose, etc.), are subject to the warranty, if any, of their manufacturer. Graco will provide purchaser with reasonable assistance in making any claim for breach of these warranties.

In no event will Graco be liable for indirect, incidental, special or consequential damages resulting from Graco supplying equipment hereunder, or the furnishing, performance, or use of any products or other goods sold hereto, whether due to a breach of contract, breach of warranty, the negligence of Graco, or otherwise.

## Graco Information

For the latest information about Graco products, visit [www.graco.com](http://www.graco.com).

**TO PLACE AN ORDER,** contact your Graco distributor or call to identify the nearest distributor.

**Phone:** 612-623-6921 **or Toll Free:** 1-800-746-1334 **Fax:** 330-966-3006

*All written and visual data contained in this document reflects the latest product information available at the time of publication. Graco reserves the right to make changes at any time without notice.*

*For patent information, see [www.graco.com/patents](http://www.graco.com/patents).*

取扱説明書原文の翻訳。This manual contains Japanese. MM 332452

**Graco Headquarters:** Minneapolis  
**International Offices:** Belgium, China, Japan, Korea

**GRACO INC. AND SUBSIDIARIES • P.O. BOX 1441 • MINNEAPOLIS MN 55440-1441 • USA**

**Copyright 2013, Graco Inc. All Graco manufacturing locations are registered to ISO 9001.**

[www.graco.com](http://www.graco.com)

Revised August 2013