

# GrindLazer™

3A0103H

EN

- *Designed to grind flat, horizontal concrete or asphalt surfaces -*
- *For removal of materials from concrete and asphalt surfaces -*
- *Professional outdoor use only -*

**Model 571002 - Forward cut line removal / bump smoothing**

GrindLazer 270 (270 cc / 9 hp)

**Model 571003 - Forward cut line removal / bump smoothing**

GrindLazer 390 (390 cc / 13 hp)

**Model 571004 - Reverse (up cut) / inlay and grooving (Must be used with LineDriver™)**

GrindLazer 480 (480 cc / 16 hp)

**Model 571260 - Reverse (up cut) / inlay and grooving (Must be used with LineDriver™)**

GrindLazer 630 (627 cc / 21 hp)

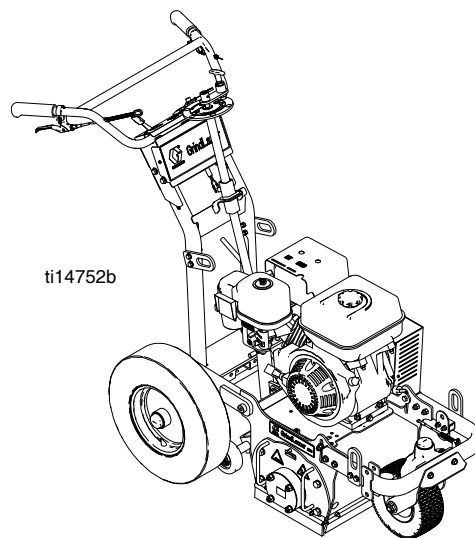

**GrindLazer 270 and 390**

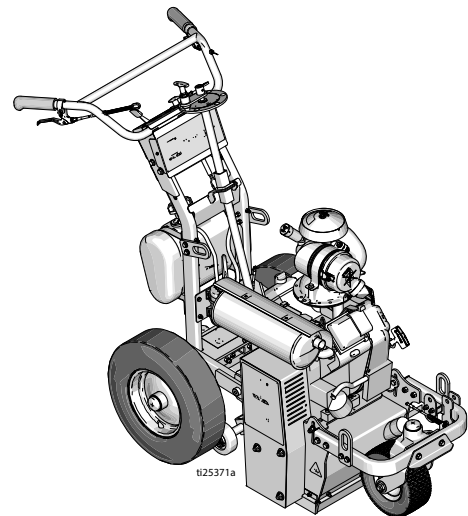

**GrindLazer 630**

**Related Manuals:**

Operation - 3A0101

Repair - 3A0102

*(Drums, cutters, and LineDriver™ sold separately)*

# Parts

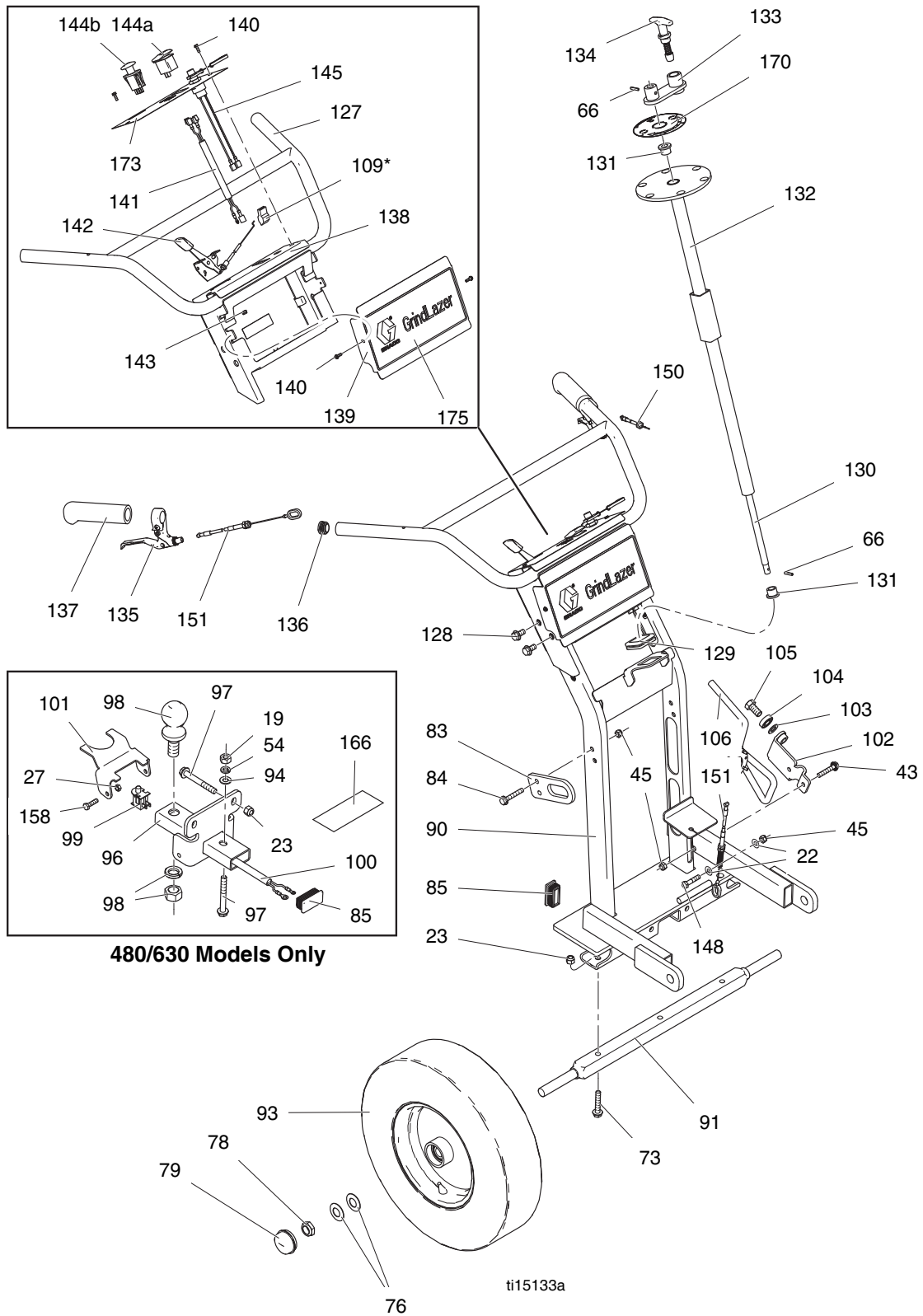

# Parts List

Ref.	Part	Description	Qty.	Ref.	Part	Description	Qty.
19	100131	NUT, full hex	2	128	112395	SCREW, cap, flng HD	4
22	100023	WASHER, flat	5	129	16C278	GROMMET, square	1
23	101566	NUT, lock	13	130	16C986	SHAFT, adjustment, cutter height	1
43	112960	SCREW, cap, flng HD	6	131	115104	BEARING, flange	2
45	111040	NUT, lock, insert, nylock, 5/16	15	132	24D072	SHAFT, crank, adjustment	1
54	100133	WASHER, lock	1	133	24C982	BRACKET, crankshaft	1
66	123984	PIN, spring	3	134	24D618	PIN, handle, scarifier	1
73	114982	SCREW, cap, flng HD	4	135	194310	LEVER, actuator	2
76	112825	SPRING, belleville	6	136	120151	RETAINER, plug	2
78	112405	NUT, lock	3	137	114659	GRIP, handle	2
79	114648	CAP, dust	3	138	16C808	PLATE, control	1
83	16C781	PLATE, lift, scarifier	4	139	16D440	COVER, control	1
84	114653	SCREW, cap, flange head	6	140	117501	SCREW, mach, slot hex wash HD	5
85	115087	PLUG, tubing	6	141	16C789	HARNESS, wire (270/390 only)	1
90	24D135	FRAME, rear	1		16C788	HARNESS, wire (480/630 only)	1
91	193405	AXLE	1	142	24E296	CONTROL, throttle cable	1
93	111020	WHEEL, pneumatic	2	143	109466	NUT, lock, hex	2
94	100731	WASHER	1	144a	114954	SWITCH, power (270/390 only)	1
96	24D544	HITCH, mount	1	114b	123682	SWITCH, power (480/630 only)	1
97	116935	SCREW, cap, flng HD	3	145	16D097	SWITCH, safety, tether, terminated	1
98	116913	BALL, trailer	1		124081	CORD, lanyard, switch safety	1
99	116833	SWITCH, safety	1	148	102547	SCREW, cap, hex HD	1
100	16C790	HARNESS, wire	1	150	123816	CABLE	1
101	16D497	ACTUATOR, switch, hitch	1	151	16A717	CABLE with spring	1
102	198891	BRACKET	1	166▲	16D005	LABEL, 16 hp control (480/630 only)	1
103	195134	SPACER, ball, guide	1	170	16D076	LABEL, scarifier cutter position	1
104	198931	BEARING	1	173▲	16C395	LABEL, ISO hazards & prevent	1
105	113961	SCREW, cap, hex HD	1	175	16D391	LABEL, brand, grindlazer	1
106	198930	ROD, brake	1				
109	114956	TERMINAL, wire, tap (270/390 only)	1				
127	24C911	BAR, handle	1				

▲ Replacement Danger and Warning labels, tags, and cards are available at no cost.

# Parts

## GrindLazer 270/390

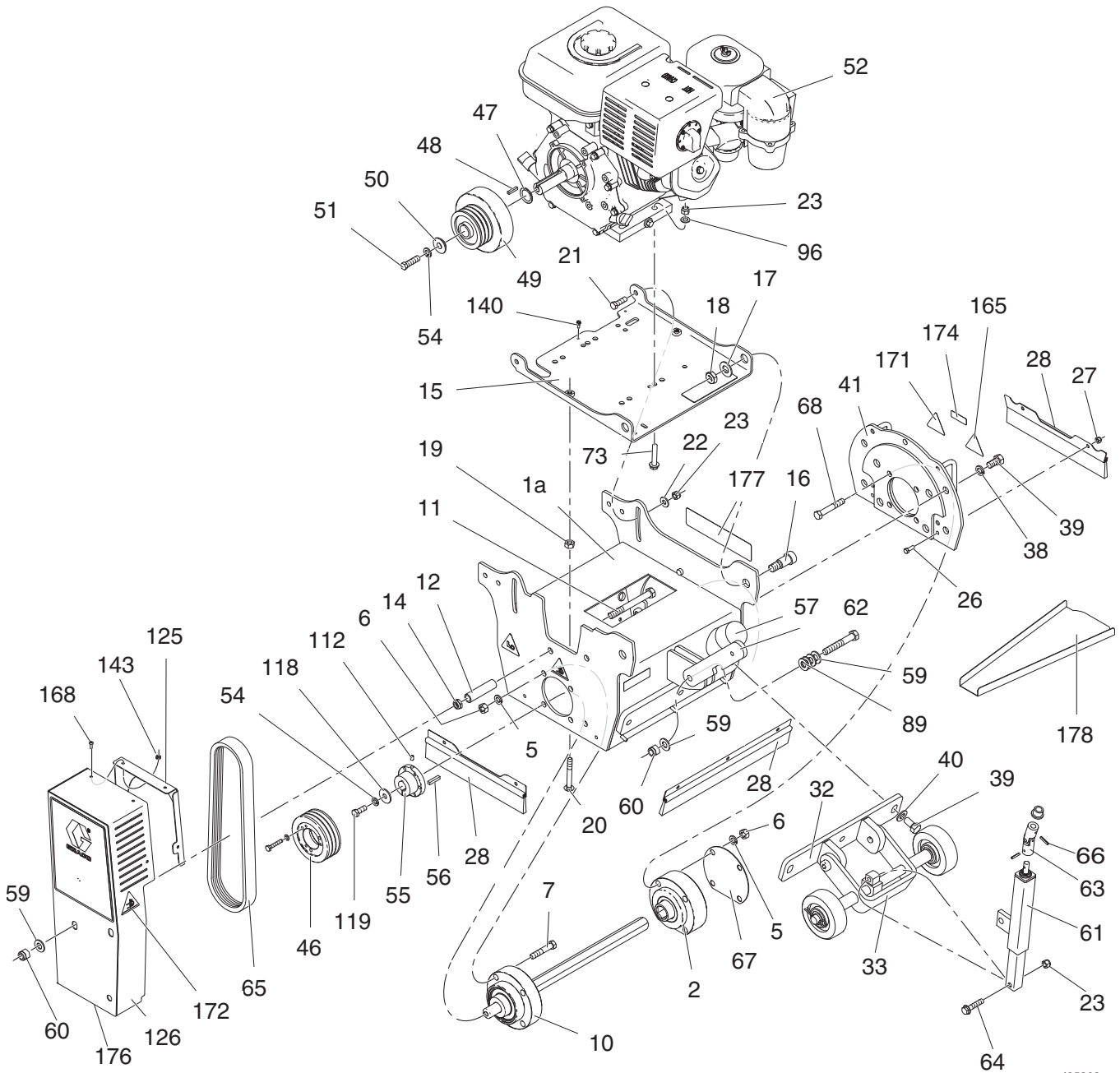

ti25393a

# Parts List

## GrindLazer 270/390

Ref.	Part	Description	Qty.	Ref.	Part	Description	Qty.
					100052	WASHER, lock (270 only)	1
				55	123799	BUSHING, QD, sheave, pulley	1
				56	16D410	KEY, square	1
1a	24D185	ENCLOSURE, 9 HP and 13 HP	1	57	123811	CAP, plug, tube, red, 2 inch	1
2	24E291	BEARING, mount	1	59	109570	WASHER, plain	9
5	100052	WASHER, lock	8	60	801020	NUT, lock	4
6	101213	NUT, full, hex	8	61	24D150	ACTUATOR, cutter height, assembly	1
7	123770	SCREW, cap, hex HD	4				
10	24E290	KIT, bearing, shaft, drive	1	62	16C667	ROD, lock, transport	1
11	123643	SCREW, cap, hex HD	3	63	123681	SWIVEL, universal, joint	1
12	16C409	SPACER, guard, belt	3	64	116780	SCREW, hex, hd, flanged	5
14	100321	NUT	3	65*	123794	BELT, 3VX375, series A	1
15	24D168	PLATE, mount, motor	1		124994	BELT, 3VX355, series B, C, D	1
16	123644	SCREW, shoulder, socket head	2	66	123984	PIN, spring	3
17	111841	WASHER, plain 5/8	2	67	16D443	COVER, dust, bearing	2
18	119554	NUT, lock, nylon, thin pattern	2	68	123982	SCREW, cap, hex head	4
19	100131	NUT, full hex	2	73	114982	SCREW, cap	8
20	124258	BOLT, carriage	1	89	119547	NUT, hex, lock, nylon, thin	1
21	100004	SCREW, cap, hex HD	2	96	112914	WASHER	4
22	100023	WASHER, flat	2	112	108851	WASHER, plain	2
23	101566	NUT, lock	13	118	100133	WASHER, lock	2
26	100022	SCREW, cap, hex HD	9	119	116596	SCREW, cap, hex head	2
27	102040	NUT, lock, hex	12	126	24D075	COVER, belt	1
28	24D584	KIT, brush, scarifier	2	140	117501	SCREW, mach, slot hex wash HD	5
32	24D170	BRACKET, arm, pivot	1	165	15K616	LABEL	1
33	16C666	BRACKET, pivot, wheel, rear, painted	1	171▲	16C393	LABEL, ISO cut foot icon	2
38	100018	WASHER, lock, spring	4	172▲	16C394	LABEL, ISO pinch hazard icon	2
39	123664	SCREW, cap, hex head	7	174	16C396	LABEL, grease equipment 50 hours	2
40	113962	WASHER, hardened, SAE	3				
41	24D173	COVER, cage, drum	1	176	16D395	LABEL, brand, Grindlazer 390 (390 only)	1
46	123697	PULLEY, sheave, QD, 3V	1		16D393	LABEL, brand, Grindlazer 270 (270 only)	1
47	16E053	SPACER, clutch (270/390 only)	1		16D396	LABEL, brand, Grindlazer 390 (390 only)	1
48	801137	KEY, square	1	177	16D394	LABEL, brand, Grindlazer 270 (270 only)	1
49	24H324	CLUTCH, centrifugal (270/390 only)	1	178	15F354	FUNNEL, oil	1
50	16D067	SPACER, engine (270 only)	1				
51	123939	SCREW, cap, hex, head (390 only)	1				
	123941	SCREW, cap, hex, head (270 only)	1				
52	123966	ENGINE, gasoline, 9 HP (270 Models)	1				
	123814	ENGINE, gasoline, 13 HP (390 Models)	1				
	123663	ENGINE, gasoline, 16 HP (480 Models)	1				
54	100133	WASHER, lock (390 only)	1				

\* KIT includes belt 65

▲ Replacement Danger and Warning labels, tags, and cards are available at no cost.

# Parts

## GrindLazer 480

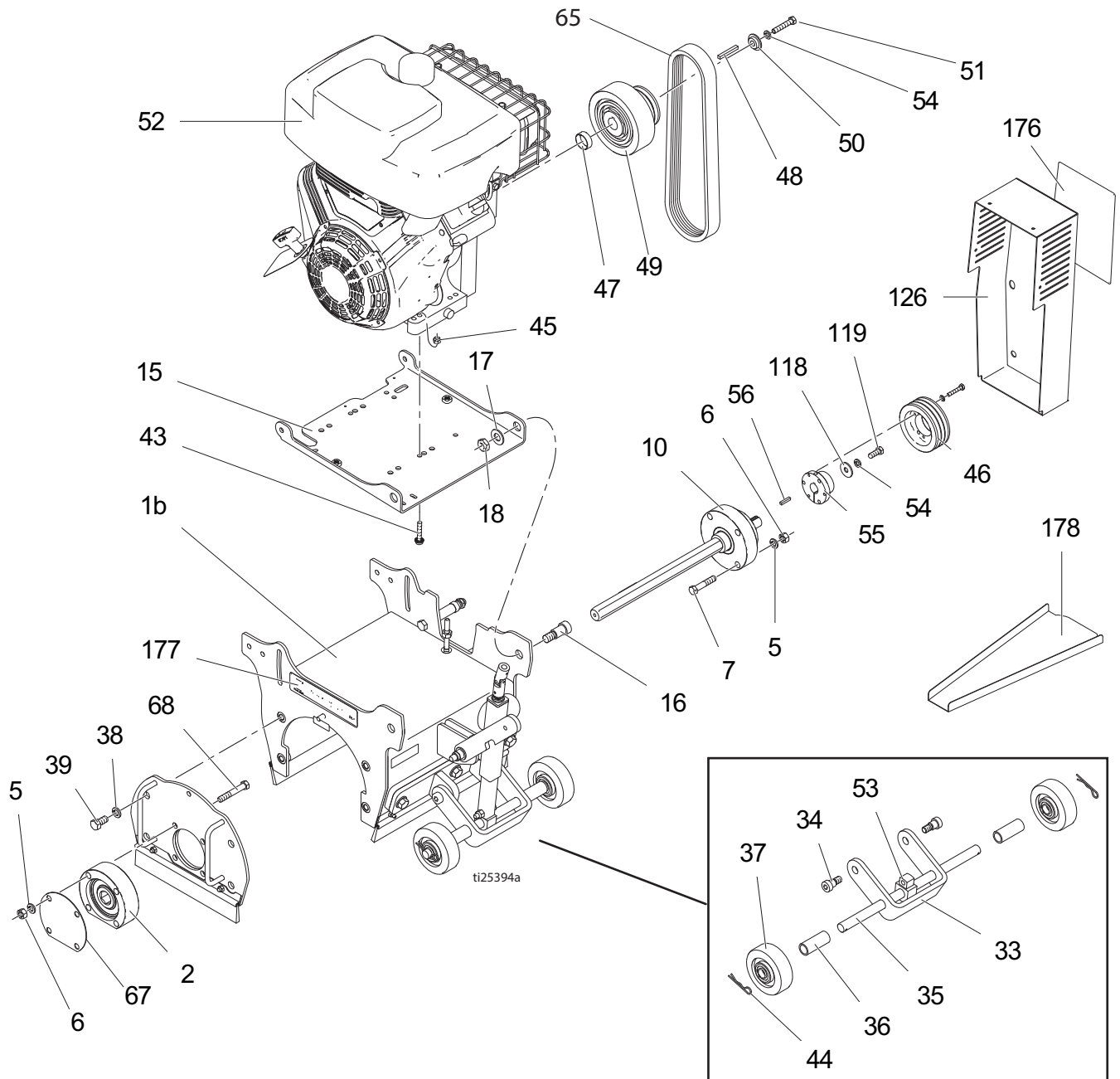

# Parts List

## GrindLazer 480

Ref.	Part	Description	Qty.	Ref.	Part	Description	Qty.
				51	123940	SCREW, cap, hex head (480 only)	1
				52	123663	ENGINE, gasoline, 16 HP (480 Models)	1
1b	24D186	ENCLOSURE, 16 HP and 21 HP	1	53	16C492	ADAPTER, shaft, height adjustment	1
2	24E291	BEARING, mount	1	54	100133	WASHER, lock (480 only)	1
5	100052	WASHER, lock	8	55	123799	BUSHING, QD, sheave, pulley	1
6	101213	NUT, full, hex	8	56	16D410	KEY, square	1
7	123770	SCREW, cap, hex HD	4	65*	123794	BELT, 3VX375, series A	1
10	24E290	KIT, bearing, shaft, drive	1		124994	BELT, 3VX355, series B, C, D	1
15	24D168	PLATE, mount, motor	1	67	16D443	COVER, dust, bearing	2
16	123644	SCREW, shoulder, socket head	2	68	123982	SCREW, cap, hex head	4
17	111841	WASHER, plain 5/8	2	112	108851	WASHER, plain	2
18	119554	NUT, lock, nylon, thin pattern	2	118	100133	WASHER, lock	2
33	16C666	BRACKET, pivot, wheel	1	119	116596	SCREW, cap, hex head	2
34	123746	SCREW, shoulder, socket head	2	126	24D075	COVER, belt	1
35	16C054	AXLE, pivot, drum, wheel	1	176	16D397	LABEL, brand, Grindlazer 480 (480 only)	1
36	16C055	SPACER, wheel, pivot	2	177	16D398	LABEL, brand, Grindlazer 480	1
37	123613	WHEEL	2	178	15F354	FUNNEL, oil	1
38	100018	WASHER, lock, spring	4				
39	123664	SCREW, cap, hex head	7				
43	112960	SCREW, cap, flng HD	6				
44	123906	PIN, cotter, hair pin	2				
45	111040	NUT, lock, insert, nylock, 5/16	15				
46	123697	PULLEY, sheave, QD, 3V	1				
47	16P716	SPACER, clutch (480 only)	1				
48	801137	KEY, square	1				
49	24H323	CLUTCH, centrifugal (480 only)	1				
50	16C708	SPACER, engine (480 only)	1				

\* KIT includes belt 65

# Parts

## GrindLazer 630

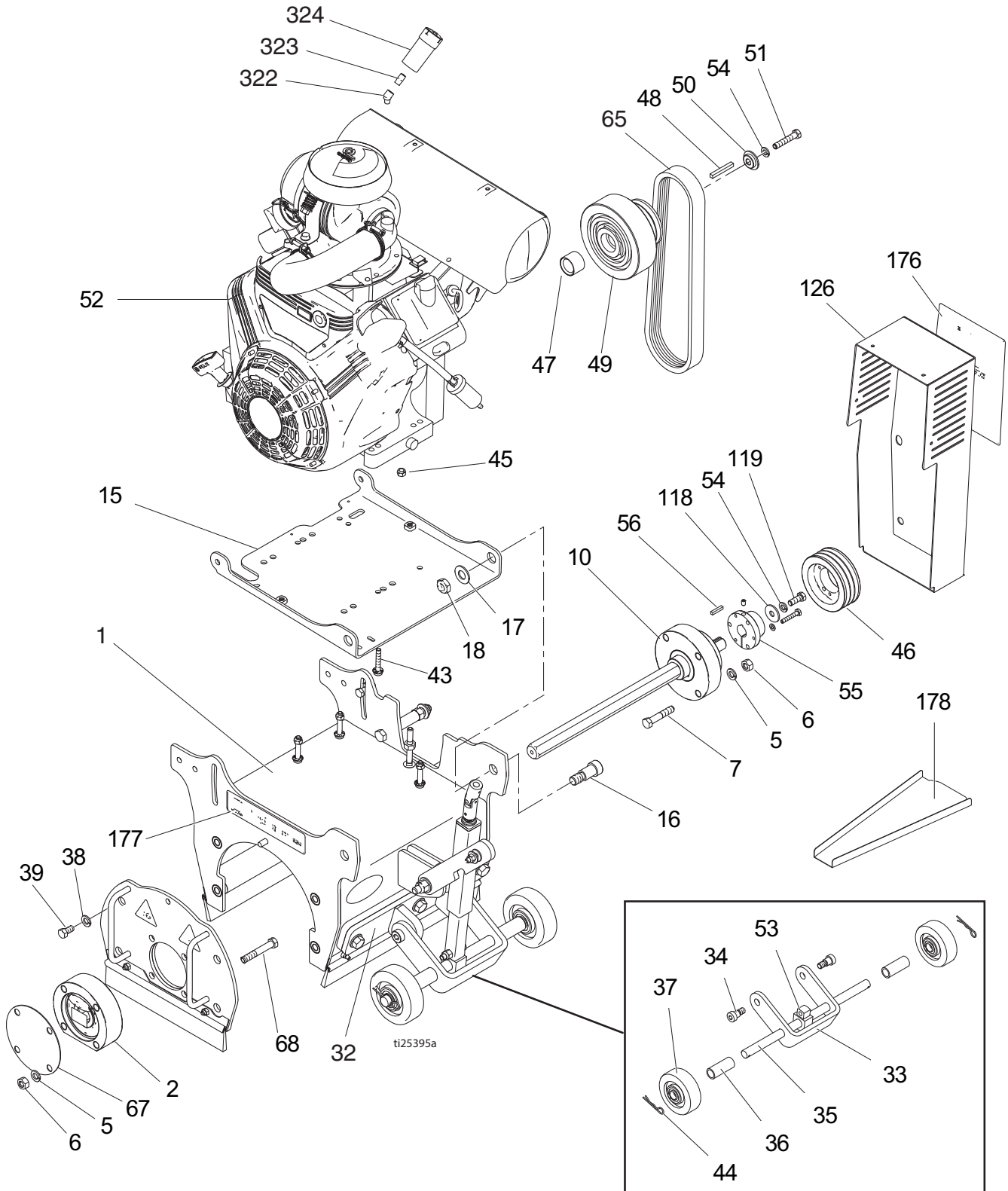



# Parts List

## GrindLazer 630

Ref.	Part	Description	Qty.	Ref.	Part	Description	Qty.
				52	123966	ENGINE, gasoline, 9 HP (270 Models)	1
1b	24D186	ENCLOSURE, 16 HP and 21 HP	1		123814	ENGINE, gasoline, 13 HP (390 Models)	1
2	24E291	BEARING, mount	1		127972	ENGINE, gasoline, 21HP (630 Models)	1
5	100052	WASHER, lock	8	53	16C492	ADAPTER, shaft, height adjustment	1
6	101213	NUT, full, hex	8	54	100133	WASHER, lock (630 only)	1
7	123770	SCREW, cap, hex HD	4	55	123799	BUSHING, QD, sheave, pulley	1
10	24E290	KIT, bearing, shaft, drive	1	56	16D410	KEY, square	1
15	24D168	PLATE, mount, motor	1	65*	124994	BELT, 3VX355	
16	123644	SCREW, shoulder, socket head	2	67	16D443	COVER, dust, bearing	2
17	111841	WASHER, plain 5/8	2	68	123982	SCREW, cap, hex head	4
18	119554	NUT, lock, nylon, thin pattern	2	118	100133	WASHER, lock	2
32	24D170	BRACKET, arm, pivot	1	119	116596	SCREW, cap, hex head	2
33	16C666	BRACKET, pivot, wheel	1	126	24D075	COVER, belt	1
34	123746	SCREW, shoulder, socket head	2	176	17D158	LABEL, brand, Grindlazer 630	1
35	16C054	AXLE, pivot, drum, wheel	1	177	17D159	LABEL, brand, Grindlazer 630	
36	16C055	SPACER, wheel, pivot	2	178	15F354	FUNNEL, oil	1
37	123613	WHEEL	2	322	113630	ELBOW	1
38	100018	WASHER, lock, spring	4	323	125509	FITTING, nipple	1
39	123664	SCREW, cap, hex head	7	324	127989	INDICATOR, air filter	1
43	112960	SCREW, cap, flng HD	6				
44	123906	PIN, cotter, hair pin	2				
45	111040	NUT, lock, insert, nylock, 5/16	15				
46	123697	PULLEY, sheave, QD, 3V	1				
47	16P716	SPACER, clutch (630 only)	1				
48	801137	KEY, square	1				
49	24H323	CLUTCH, centrifugal (630 only)	1				
50	16C708	SPACER, engine (630 only)	1				
51	123940	SCREW, cap, hex head (630 only)	1				

\* KIT includes belt 65

# Parts

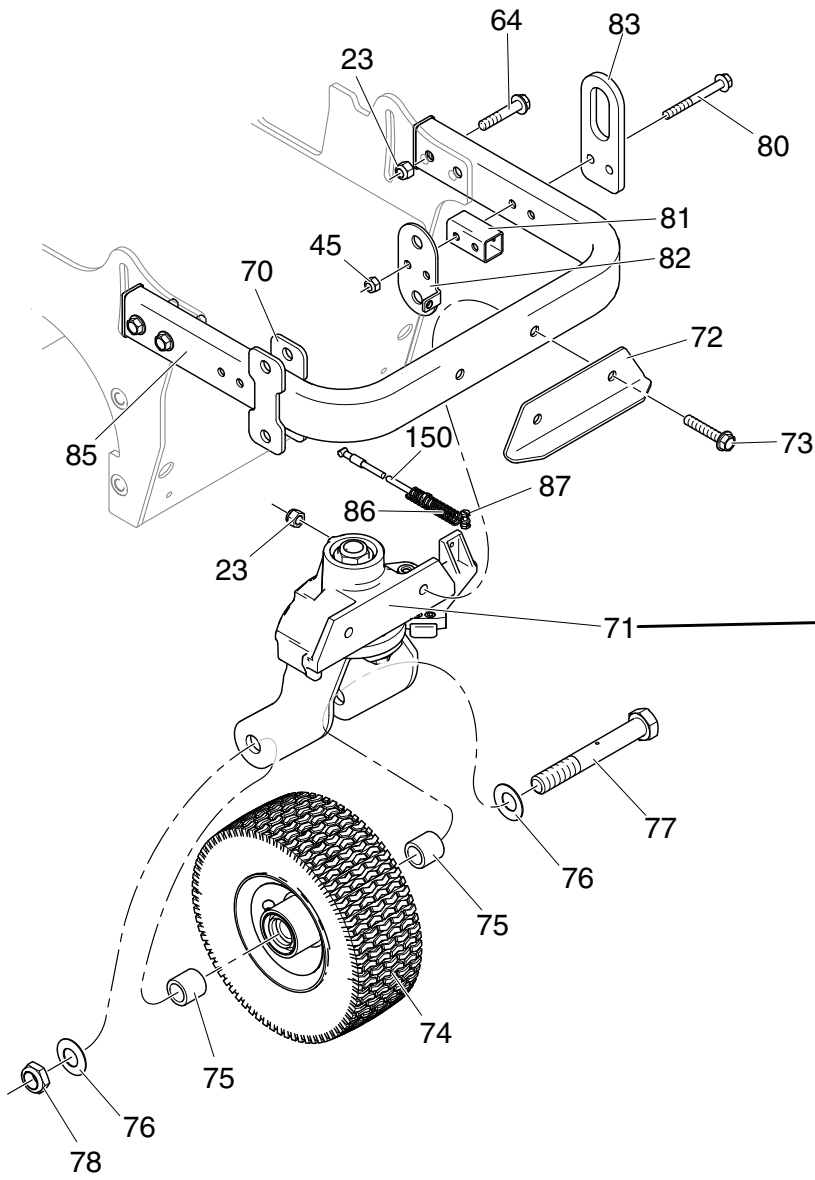

ti31693a

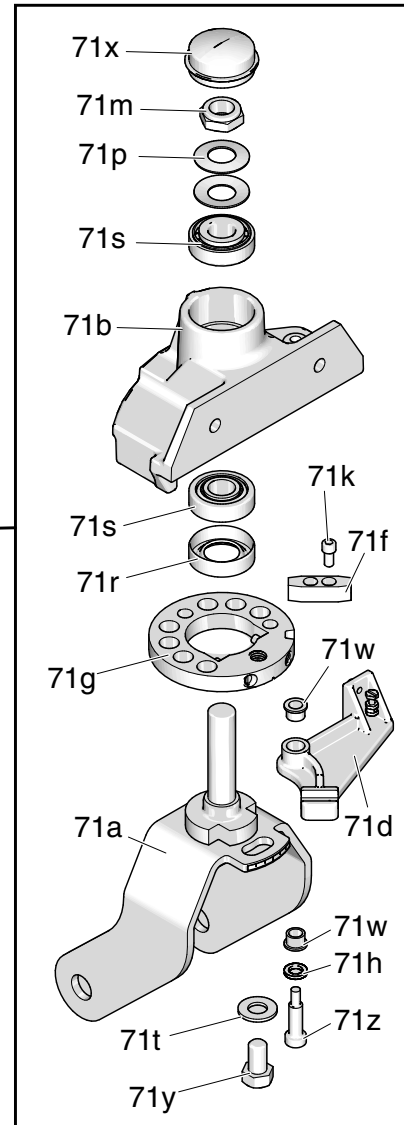

## Parts List

Ref.	Part	Description	Qty.	Ref.	Part	Description	Qty.
23	101566	NUT, lock	13	71y	114681	SCREW	1
45	111040	NUT, lock, insert, nylock, 5/16	15	71z	120476	BOLT	1
64	116780	SCREW, hex, HD, flanged	5	72	240991	BRACKET, caster, front	1
70	24D184	FRAME, front	1	73	114982	SCREW, cap, flng HD	4
71	24H246	CASTER, LineLazer	1	74	114549	WHEEL, pneumatic	1
71a	17H485	SHAFT, fork	1	75	193658	SPACER, seal	2
71b*	15G952	BRACKET	1	76	112825	SPRING, belleville	6
71d	193528	ARM, detent	1	77	113471	SCREW, cap, hex HD	1
71f	193662	STOP, wedge	1	78	112405	NUT, lock	3
71g	17H486	DISK, adjuster	1	80	120229	SCREW, hex flange	2
71h	15J603	WASHER	1	81	16C111	SPACER, support, cable	1
71j	108483	SCREW, shoulder, sch	1	82	15F910	BRACKET, cable	1
71k	110754	SCREW, cap	2	83	16C781	PLATE, lift, scarifier	4
71m	112405	NUT, lock	4	85	115087	PLUG, tubing	6
71p	119563	SPRING, belleville	2	86	114682	SPRING, compression	1
71r	113484	SEAL	1	87	114802	STOP, wire	1
71s*	113485	BEARING	2	150	123816	CABLE	1
71t	113962	WASHER	1				
71w	114548	BEARING, bronze	2				
71x	114648	CAP, dust	3				

\* Included in Bracket Repair Kit 240940.

# Parts

## GrindLazer 630 Models Only

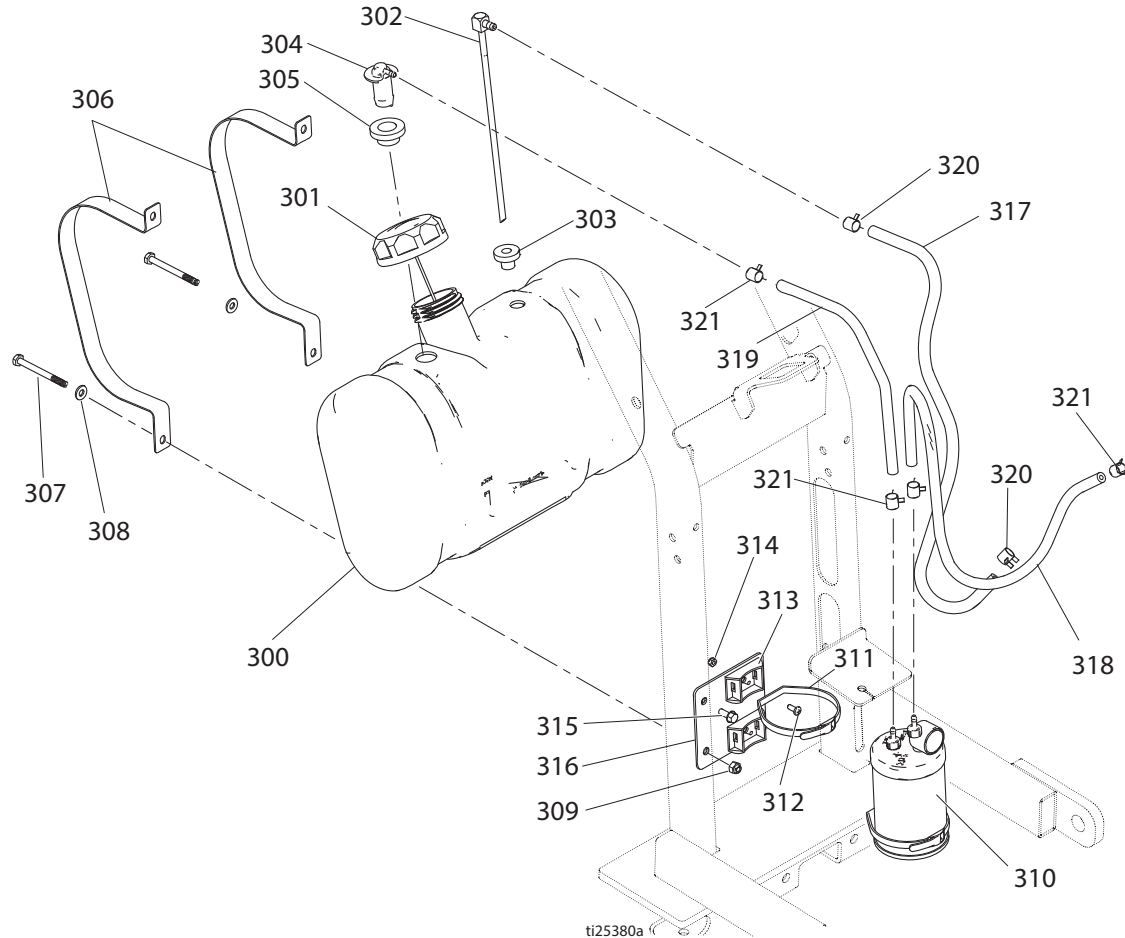

## Parts List

Ref.	Part	Description	Qty.	Ref.	Part	Description	Qty.
300	17C978	KIT, fuel tank, 2 gallon <i>includes 302, 303, 304, 305</i>	1	312	116610	SCREW	2
301	17C989	CAP, fuel	1	313	16G758	BRACKET	2
302	17C988	PICK UP FUEL	1	314	115483	NUT	2
303	16G754	GROMMET	1	315	112774	SCREW	1
304	17D030	GROMMET	1	316	17D019	BRACKET	1
305	17D029	VALVE, fuel	1	317	17C983	HOSE, 1/4" 19 in.	1
306	17D021	STRAP, mounting	2	318	17C984	HOSE, 3/6" 21 in.	1
307	103547	SCREW	4	319	17C985	HOSE, 3/16" 14 in.	2
308	110755	WASHER	4	320	16G757	CLAMP, hose 1/4	2
309	102040	NUT	4	321	16G162	CLAMP, hose 3/16	5
310	17C979	CART, carbon	1				
311	16G756	STRAP	2				

# Drum and Cutter Parts

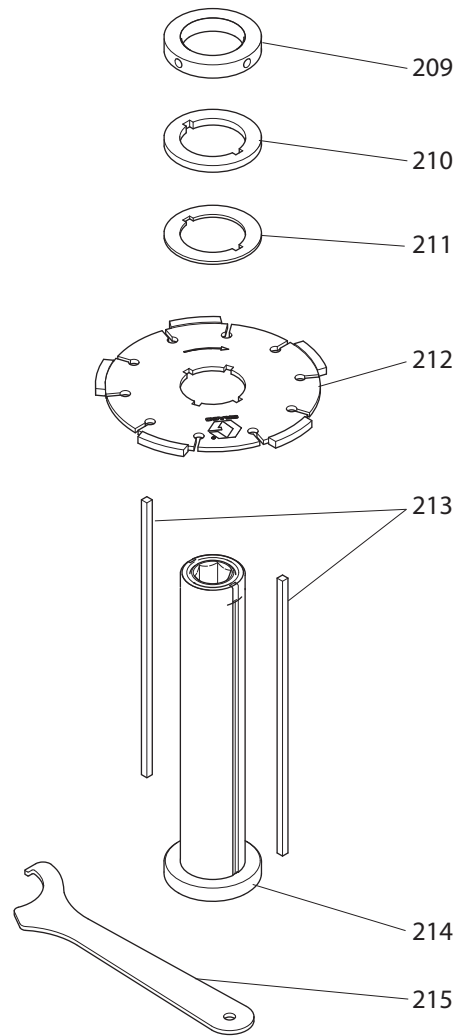
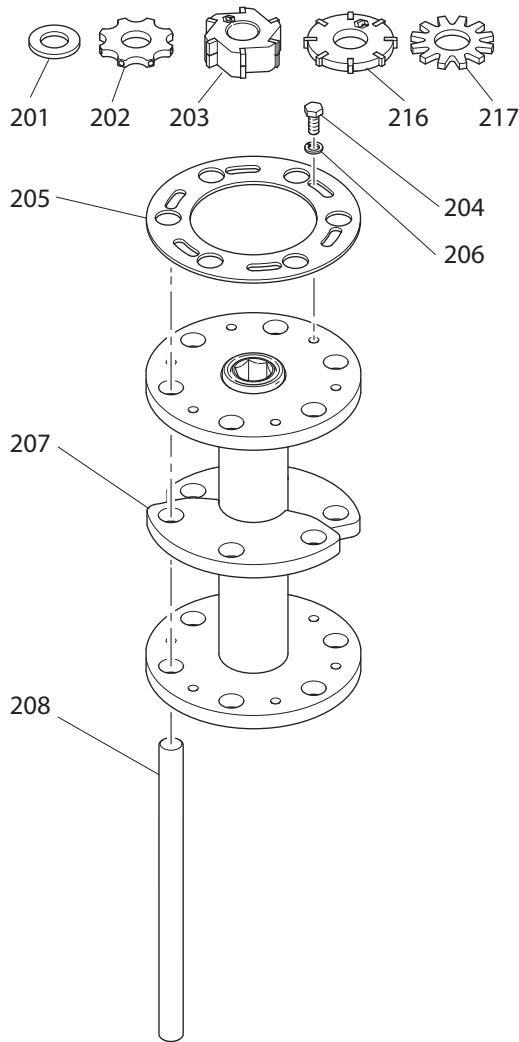

ti25381a

## Drum and Cutter Parts List

Ref.	Part	Description	Qty	Ref.	Part	Description	Qty
201	24D981	SPACER, 20 pack	◆	210	16A257	SPACER, 1/4 in.	◆
202	24D612	CUTTER, 20 pack	◆	211	16A258	SPACER, 1/8 in.	◆
203	24D613	MILLER, 6 pack	◆	212	24E289	BLADE, diamond	◆
204	123791	SCREW	12	213	123252	SQUARE KEY	2
205	24D980	PLATE, 2 pack	2	214	24D982	DRUM	◆
206	100186	WASHER, lock	12	215	16E065	WRENCH, spanner	1
207	16A654	DRUM	1	216	24F213	FULLCUT flail cutter, 20 pack	◆
208	24D979	ROD, 6 pack	6	217	24P818	STEEL cutter, 25 pack	◆
209	16A259	CAP, end, threaded	◆	◆ Quantities will vary. See chart on page 14.			

# GrindLazer™ Cutter Assemblies

8-Point Flail: Tungsten Carbide Cutter		Application: All purpose removal of paint, epoxy, and thermoplastic markings, bump-smoothing, and anti-slip grooving					
Ref.	Part	Description	Cut Width	Cutters	Spacers	Rods	End Plates
202	24D612	Replacement 8pt Flail, Tungsten Carbide Cutters (20 per pack)		20			
	24D182	Completely assembled drum for <b>general purpose</b>	*6 in. / 15.25 cm	84	234	6	2
	24D180	Completely assembled drum for <b>general purpose</b>	*8 in. / 20.5 cm	114	186	6	2
	24B957	Completely assembled drum for <b>general purpose</b>	*10 in. / 25.5 cm	138	150	6	2
	24E854	Completely assembled drum for <b>Fine Finish</b>	*6 in. / 15.25 cm	108	198	6	2
	24E855	Completely assembled drum for <b>Fine Finish</b>	*8 in. / 20.5 cm	144	138	6	2
	24E856	Completely assembled drum for <b>Fine Finish</b>	*10 in. / 25.5 cm	174	90	6	2

See Repair manual for additional **Cutter Stacking Recommendations**.

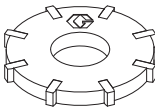
8-Point FullCut™ Flail: Tungsten Carbide Cutter		Application: All purpose removal of paint, epoxy, thermoplastic markings, bump-smoothing, anti-slip grooving, and inlay applications for a smooth finish					
Ref.	Part	Description	Cut Width	Cutters	Spacers	Rods	End Plates
216	24F213	Replacement 8pt FullCut, Tungsten Carbide Cutters (20pack)		20			
	24F184	Completely assembled drum for Ultra Fine Finish	6 in. / 15.25 cm	84	258	6	2
	24F185	Completely assembled drum for Ultra Fine Finish	8 in. / 20.5 cm	108	210	6	2
	24F186	Completely assembled drum for Ultra Fine Finish	10 in. / 25.5 cm	138	162	6	2

See Repair manual for additional **Cutter Stacking Recommendations**.

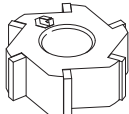
6-Point Miller: Tungsten Carbide Cutter		Application: Specifically used for thermoplastic, tape removal, and built-up paint					
Ref.	Part	Description	Cut Width	Cutters	Spacers	Rods	End Plates
203	24D613	Replacement 6pt Miller, Tungsten Carbide Cutters (6 pack)		6			
	24E214	Completely assembled drum with cutters	6 in. / 15.25 cm	30	204	6	2
	24D585	Completely assembled drum with cutters	8 in. / 20.5 cm	42	132	6	2
	24D183	Completely assembled drum with cutters	10 in. / 25.5 cm	54	66	6	2

See Repair manual for additional **Cutter Stacking Recommendations**.

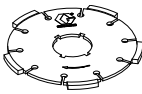
Diamond Blades		Applications: Specifically used to inlay and groove concrete and asphalt pavement					
Ref.	Part	Description	Cut Width	Blades	1/8 in. Blade Spacers	1/4 in. End Spacers	Square Key
212	24E289	Replacement Diamond Blade	1/4 in. / 6.35 cm	1			
	24B965	Completely assembled drum for <b>pavement grooving/inlay</b>	5 in. / 12.75 cm	30	204	21	2
	24D583	Completely assembled drum for <b>pavement grooving/inlay</b>	10 in. / 25.5 cm	42	132	2	2

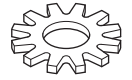

12-Point Beam: Steel Cutter		<b>Applications: All purpose removal of paint, and coatings from floors. Also used for grease, dirt and ice build up.</b>					
Ref.	Part	Description	Cut Width	Cutters	Spacers	Rods	End Plates
217	24P818	Replacement 12pt Beam, Steel Cutters (25 pack)		25			
	24P714	Completely assembled drum for smooth finishes	6 in. / 15.25 cm	126	222	6	2
	24P715	Completely assembled drum for smooth finishes	8 in. / 20.5 cm	174	156	6	2
	24P716	Completely assembled drum for smooth finishes	10 in. / 25.5 cm	204	114	6	2

See Repair manual for additional **Cutter Stacking Recommendations.**

<b>Drum Components</b>			
Ref.	Part	Description	Application
	24D610	Completely assembled drum <b>without cutters and spacers</b>	For use with all Tungsten Carbide Cutters
208	24D979	Replacement Drum Rods	For use with all Tungsten Carbide Cutters (6 pack)
205	24D980	Replacement Drum End Plates	For use with all Tungsten Carbide Cutters (2 pack)
201	24D981	Replacement Steel Spacers	For use with all Tungsten Carbide Cutters (20 pack)
209	16A259	Threaded End Cap	For use with all Diamond Blade Cutters
210	16A257	1/4 in. Spacer	For use with all Diamond Blade Cutters
211	16A258	1/8 in. Spacer	For use with all Diamond Blade Cutters
213	123252	Square Key	For use with all Diamond Blade Cutters
214	24D982	Assembled Diamond Blade drum without blades and spacers	For use with all Diamond Blade Cutters

# Graco Standard Warranty

Graco warrants all equipment referenced in this document which is manufactured by Graco and bearing its name to be free from defects in material and workmanship on the date of sale to the original purchaser for use. With the exception of any special, extended, or limited warranty published by Graco, Graco will, for a period of twelve months from the date of sale, repair or replace any part of the equipment determined by Graco to be defective. This warranty applies only when the equipment is installed, operated and maintained in accordance with Graco's written recommendations.

This warranty does not cover, and Graco shall not be liable for general wear and tear, or any malfunction, damage or wear caused by faulty installation, misapplication, abrasion, corrosion, inadequate or improper maintenance, negligence, accident, tampering, or substitution of non-Graco component parts. Nor shall Graco be liable for malfunction, damage or wear caused by the incompatibility of Graco equipment with structures, accessories, equipment or materials not supplied by Graco, or the improper design, manufacture, installation, operation or maintenance of structures, accessories, equipment or materials not supplied by Graco.

This warranty is conditioned upon the prepaid return of the equipment claimed to be defective to an authorized Graco distributor for verification of the claimed defect. If the claimed defect is verified, Graco will repair or replace free of charge any defective parts. The equipment will be returned to the original purchaser transportation prepaid. If inspection of the equipment does not disclose any defect in material or workmanship, repairs will be made at a reasonable charge, which charges may include the costs of parts, labor, and transportation.

**THIS WARRANTY IS EXCLUSIVE, AND IS IN LIEU OF ANY OTHER WARRANTIES, EXPRESS OR IMPLIED, INCLUDING BUT NOT LIMITED TO WARRANTY OF MERCHANTABILITY OR WARRANTY OF FITNESS FOR A PARTICULAR PURPOSE.**

Graco's sole obligation and buyer's sole remedy for any breach of warranty shall be as set forth above. The buyer agrees that no other remedy (including, but not limited to, incidental or consequential damages for lost profits, lost sales, injury to person or property, or any other incidental or consequential loss) shall be available. Any action for breach of warranty must be brought within two (2) years of the date of sale.

**GRACO MAKES NO WARRANTY, AND DISCLAIMS ALL IMPLIED WARRANTIES OF MERCHANTABILITY AND FITNESS FOR A PARTICULAR PURPOSE, IN CONNECTION WITH ACCESSORIES, EQUIPMENT, MATERIALS OR COMPONENTS SOLD BUT NOT MANUFACTURED BY GRACO.** These items sold, but not manufactured by Graco (such as electric motors, switches, hose, etc.), are subject to the warranty, if any, of their manufacturer. Graco will provide purchaser with reasonable assistance in making any claim for breach of these warranties.

In no event will Graco be liable for indirect, incidental, special or consequential damages resulting from Graco supplying equipment hereunder, or the furnishing, performance, or use of any products or other goods sold hereto, whether due to a breach of contract, breach of warranty, the negligence of Graco, or otherwise.

## **FOR GRACO CANADA CUSTOMERS**

The Parties acknowledge that they have required that the present document, as well as all documents, notices and legal proceedings entered into, given or instituted pursuant hereto or relating directly or indirectly hereto, be drawn up in English. Les parties reconnaissent avoir convenu que la rédaction du présente document sera en Anglais, ainsi que tous documents, avis et procédures judiciaires exécutés, donnés ou intentés, à la suite de ou en rapport, directement ou indirectement, avec les procédures concernées.

# Graco Information

For the latest information about Graco products, visit [www.graco.com](http://www.graco.com).

For patent information, see [www.graco.com/patents](http://www.graco.com/patents).

**TO PLACE AN ORDER**, contact your Graco distributor or call 1-800-690-2894 to identify the nearest distributor.

*All written and visual data contained in this document reflects the latest product information available at the time of publication.  
Graco reserves the right to make changes at any time without notice.*

*For patent information, see [www.graco.com/patents](http://www.graco.com/patents).*

Original instructions. This manual contains English. MM 3A0103

**Graco Headquarters:** Minneapolis  
**International Offices:** Belgium, China, Japan, Korea

**GRACO INC. AND SUBSIDIARIES • P.O. BOX 1441 • MINNEAPOLIS MN 55440-1441 • USA**

**Copyright 2012, Graco Inc. All Graco manufacturing locations are registered to ISO 9001.**

[www.graco.com](http://www.graco.com)

Revision H, August 2018