

# LineLazer™ V 3900, 5900 Airless Line Stripers

## Standard Series and High Production (HP) Auto Series

3A3389D

EN

***For the application of line striping materials.***

***For professional use only.***

***For outdoor use only.***

***Not for use in explosive atmospheres or hazardous locations.***

*Maximum Operating Pressure: 3300 psi (22.8 MPa, 228 bar)*



### Important Safety Instructions

Read all warnings and instructions in this manual and in related manuals.

Be familiar with the controls and the proper usage of the equipment.

Save these instructions.

#### Related Manuals:

3A3388	Operation
311254	Gun
309277	Pump
3A3428	Auto-Layout Applications Methods

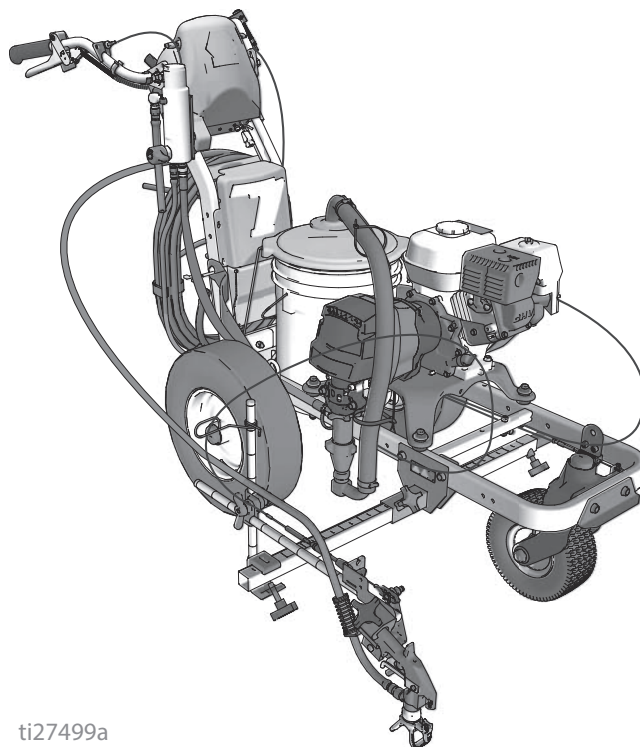

ti27499a

*Use only genuine Graco replacement parts.  
The use of non-Graco replacement parts may void warranty.*



# Contents

<b>Models</b> .....	<b>3</b>
<b>Tip Selection</b> .....	<b>4</b>
<b>LineLazer V 3900, 5900 Parts</b> .....	<b>5</b>
<b>Parts Drawing - LineLazer V 3900, 5900</b> .....	<b>6</b>
<b>Parts List</b> .....	<b>7</b>
<b>Parts Drawing - LineLazer V 3900, 5900</b> .....	<b>8</b>
<b>Parts List</b> .....	<b>9</b>
<b>Parts Drawing - Drive and Pinion Housing Assemblies</b> .....	<b>10</b>
<b>Parts List</b> .....	<b>11</b>
<b>Parts Drawing - LineLazer V 3900, 5900</b> .....	<b>12</b>
<b>Parts List</b> .....	<b>13</b>
Swivel Wheel Assembly .....	13
Filter .....	13
<b>Parts Drawing - LineLazer V 3900, 5900</b> .....	<b>14</b>
<b>Parts List</b> .....	<b>15</b>
Gun Holder and Arm .....	15
Gun Trigger .....	15
<b>Parts Drawing - LineLazer V 3900, 5900</b> .....	<b>16</b>
<b>Parts List</b> .....	<b>17</b>
<b>Distance Sensor Replacement</b> .....	<b>18</b>
<b>Wiring Diagram (Standard Series)</b> .....	<b>19</b>
<b>Wiring Diagram (HP Auto Series)</b> .....	<b>20</b>
<b>Technical Data</b> .....	<b>21</b>
<b>Notes</b> .....	<b>25</b>
<b>Graco Standard Warranty</b> .....	<b>26</b>
<b>Graco Information</b> .....	<b>26</b>





<b>Manual</b>	<b>Language</b>
<b>3A3389</b>	English
<b>3A3865</b>	French
<b>3A3866</b>	Spanish
<b>3A3873</b>	Dutch
<b>3A3876</b>	German
<b>3A3879</b>	Italian
<b>3A3889</b>	Turkish
<b>3A3877</b>	Greek
<b>3A3870</b>	Croatian
<b>3A3884</b>	Portuguese
<b>3A3872</b>	Danish
<b>3A3875</b>	Finnish
<b>3A3888</b>	Swedish
<b>3A3882</b>	Norwegian
<b>3A3703</b>	Russian
<b>3A3874</b>	Estonian
<b>3A3880</b>	Latvian
<b>3A3881</b>	Lithuanian
<b>3A3883</b>	Polish
<b>3A3878</b>	Hungarian
<b>3A3871</b>	Czech
<b>3A3886</b>	Slovakian
<b>3A3887</b>	Slovenian
<b>3A3885</b>	Romanian
<b>3A3916</b>	Bulgarian

# Models

LineLazer V 3900					
Model:	Standard 1 Manual Gun	Standard 2 Manual Guns	HP Auto 1 Auto Gun	HP Auto 1 Auto Gun 1 Manual Gun	HP Auto 2 Auto Guns
17H449	✓				
17H450		✓			
17K577			✓		
17H451			✓ with laser		
17K638				✓	
17H452				✓ with laser	
17K579					✓
17H453					✓ with laser
LineLazer V 5900					
Model:	Standard 1 Manual Gun	Standard 2 Manual Guns	HP Auto 1 Auto Gun	HP Auto 1 Auto Gun 1 Manual Gun	HP Auto 2 Auto Guns
17H454	✓				
17H455		✓			
17K580			✓		
17H456			✓ with laser		
17K636				✓	
17H457				✓ with laser	
17K581					✓
17H458					✓ with laser

\* All auto guns can be actuated manually.

# Tip Selection

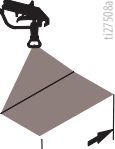
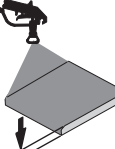
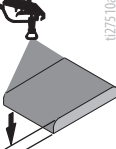
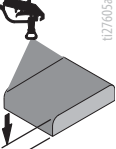
 1127500a	 1127505a in. (cm)	 1127506a in. (cm)	 1127507a in. (cm)	 1127508a in. (cm)	 1127509a	 1127510a	 1127605a
LL5213*	2 (5)				✓		
LL5215*	2 (5)					✓	
LL5217		4 (10)				✓	
LL5219		4 (10)					✓
LL5315*		4 (10)			✓		
LL5317		4 (10)			✓		
LL5319		4 (10)				✓	
LL5321		4 (10)				✓	
LL5323		4 (10)				✓	
LL5325		4 (10)					✓
LL5327		4 (10)					✓
LL5329		4 (10)					✓
LL5331		4 (10)					✓
LL5333		4 (10)					✓
LL5335		4 (10)					✓
LL5355		4 (10)					✓
LL5417			6 (15)		✓		
LL5419			6 (15)		✓		
LL5421			6 (15)		✓		
LL5423			6 (15)			✓	
LL5425			6 (15)			✓	
LL5427			6 (15)			✓	
LL5429			6 (15)			✓	
LL5431			6 (15)				✓
LL5435			6 (15)				✓
LL5621				12 (30)	✓		
LL5623				12 (30)	✓		
LL5625				12 (30)	✓		
LL5627				12 (30)	✓		
LL5629				12 (30)	✓		
LL5631				12 (30)		✓	
LL5635				12 (30)		✓	
LL5639				12 (30)			✓

\* Use 100 mesh filter to reduce tip clogs.

# LineLazer V 3900, 5900 Parts

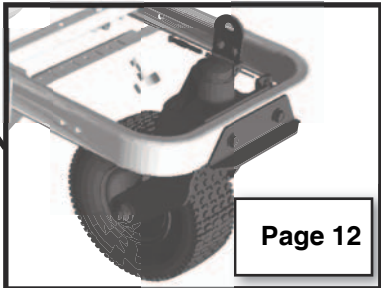
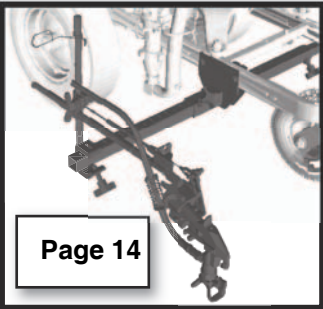
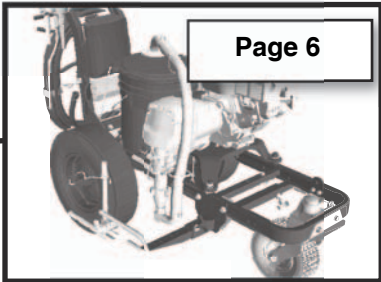
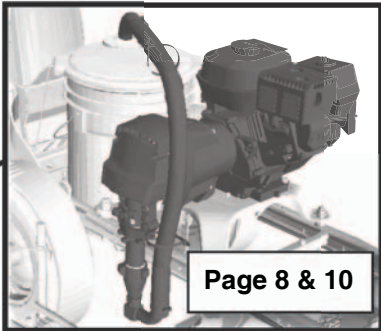
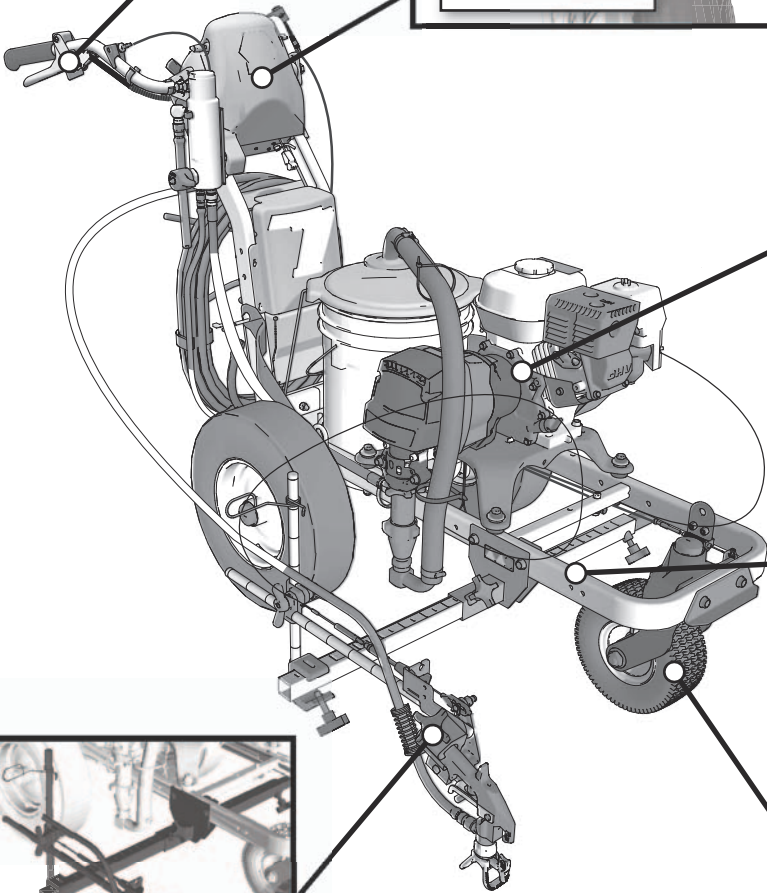
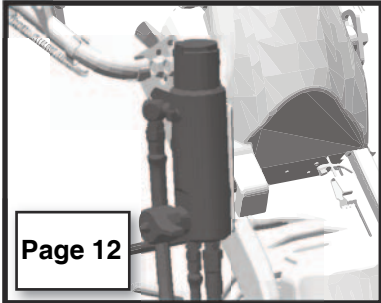
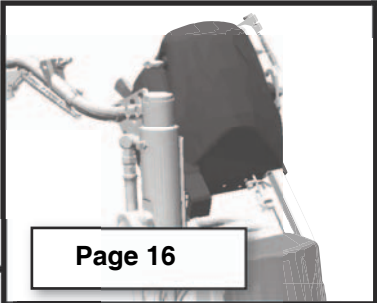
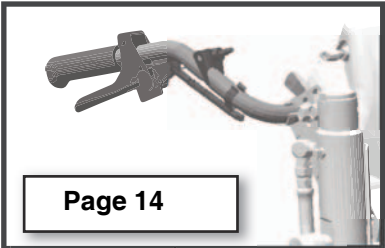

# Parts Drawing - LineLazer V 3900, 5900

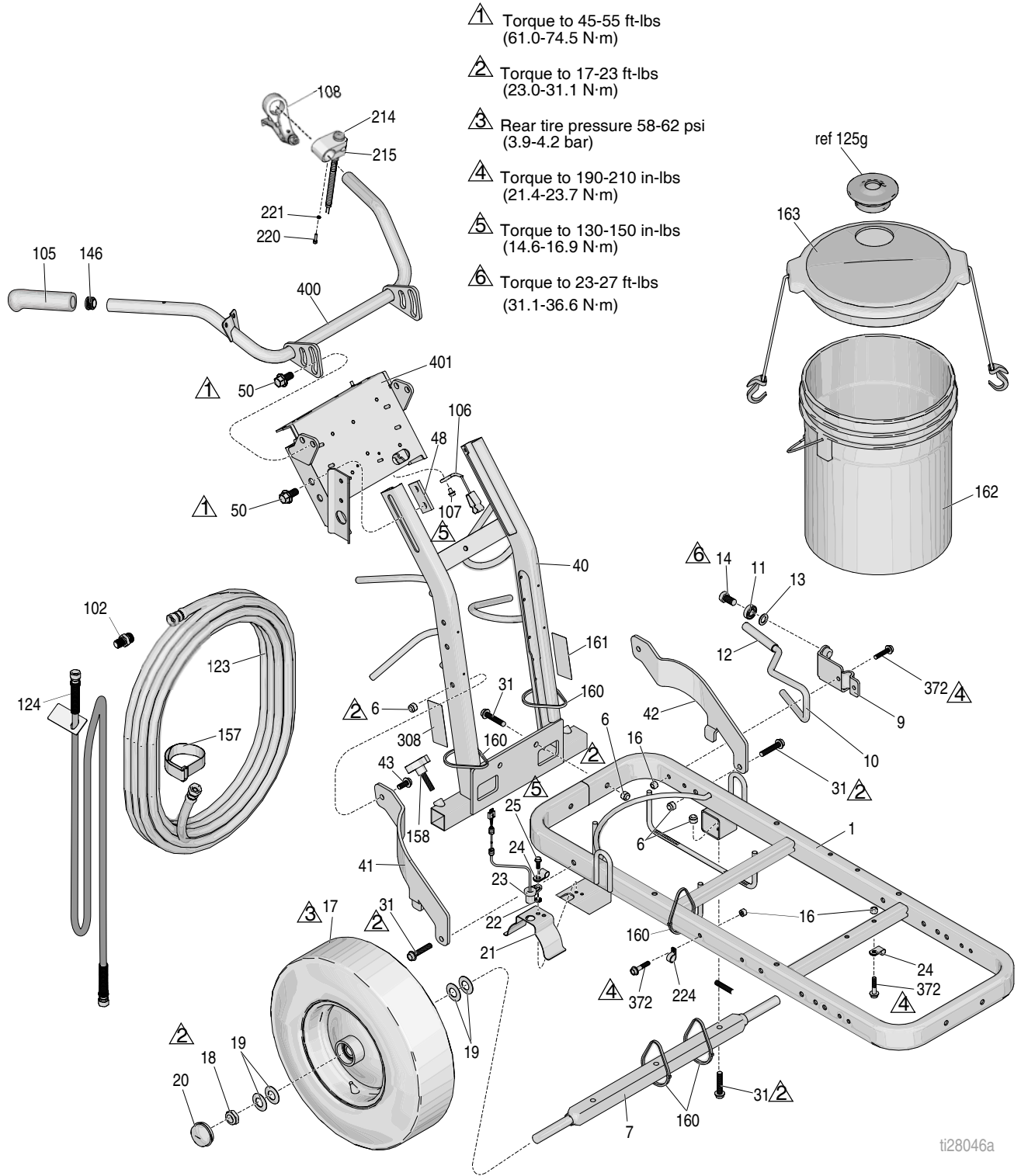

# Parts List

Ref	Part	Description	Qty	Ref	Part	Description	Qty
1	287623	FRAME, linestriper (painted)	1	50	17J136	SCREW, hex, flange head	4
6	101566	NUT, lock	8	102	196176	ADAPTER, nipple	1
7	193405	AXLE	1	105	114659	GRIP	2
9	198891	BRACKET	1	106	237686	GROUND WIRE	1
10	198930	ROD, brake (includes 12)	1	107	107257	SCREW, thread forming, hex hd	1
11	198931	BEARING	1	108	194310	LEVEL, actuator	1
12	114808	CAP, vinyl	1	123	245225	HOSE, 3/8" x 50'	1
13	195134	SPACER, ball, guide	1	124	245798	HOSE, coupled 1/4" x 7'	1
14	113961	SCREW, cap, hex hd	1	125g	278722	GASKET	1
16	111040	NUT, lock, insert, nylock, 5/16	5	146	120151	RETAINER, caplug	2
17†	255162	WHEEL, pneumatic w sensor ring (right)	1	157	114271	STRAP	1
	111020	WHEEL, pneumatic w/o sensor ring (left)	1	158	108471	KNOB, pronged	1
18	112405	NUT, lock	2	160	404989	STRAP, tie	5
19	112825	WASHER	4	161	17K394	LABEL, gmax warning fire & skin	1
20	114648	CAP, dust	2	162	115077	PAIL, plastic	1
21	15J088	SHIELD, distance sensor	1	163	24U241	KIT, pail cover	1
22	15K452	SPACER, round,.500 o.d.	1	214*	17J236	SWITCH, push button	1
23	15K357	SENSOR, distance	1	215*	15K162	BLOCK, switch	1
24	108868	CLAMP, wire	2	220*	C19277	WASHER, lock, split, hi-collar	1
25	260212	SCREW, hex washer hd, thd form	1	221*	C20004	SCREW, cap	1
31	114982	SCREW, cap, flng hd	6	224	17H721	CLAMP, wire	2
40	24Y665	FRAME, handle upright, painted	1	308	17K392	LABEL	1
41	15F576	BRACE, right (painted)	1	372	112960	SCREW	5
42	15F577	BRACE, left (painted)	1	400	24Y641	BAR, handle	1
43	128977	SCREW, cap button hd	2	401	24Y642	CONTROL PLATE	1
48	17J125	BRACKET, slide	2				

† Replace both at the same time

\* HP Auto only

# Parts Drawing - LineLazer V 3900, 5900

Torque to 130-150 in-lbs  
(14.6-16.9 N·m)

Torque to 190-210 in-lbs  
(21.4-23.7 N·m)

Torque to 17-23 ft-lbs  
(23.0-31.1 N·m)

Torque to 170-190 in-lbs  
(19.2-21.4 N·m)

Torque to 115-135 in-lbs  
(12.9-15.2 N·m)

Torque to 30-35 in-lbs  
(3.3-3.9 N·m)

Torque to 8-12 in-lbs  
(0.9-1.3 N·m)

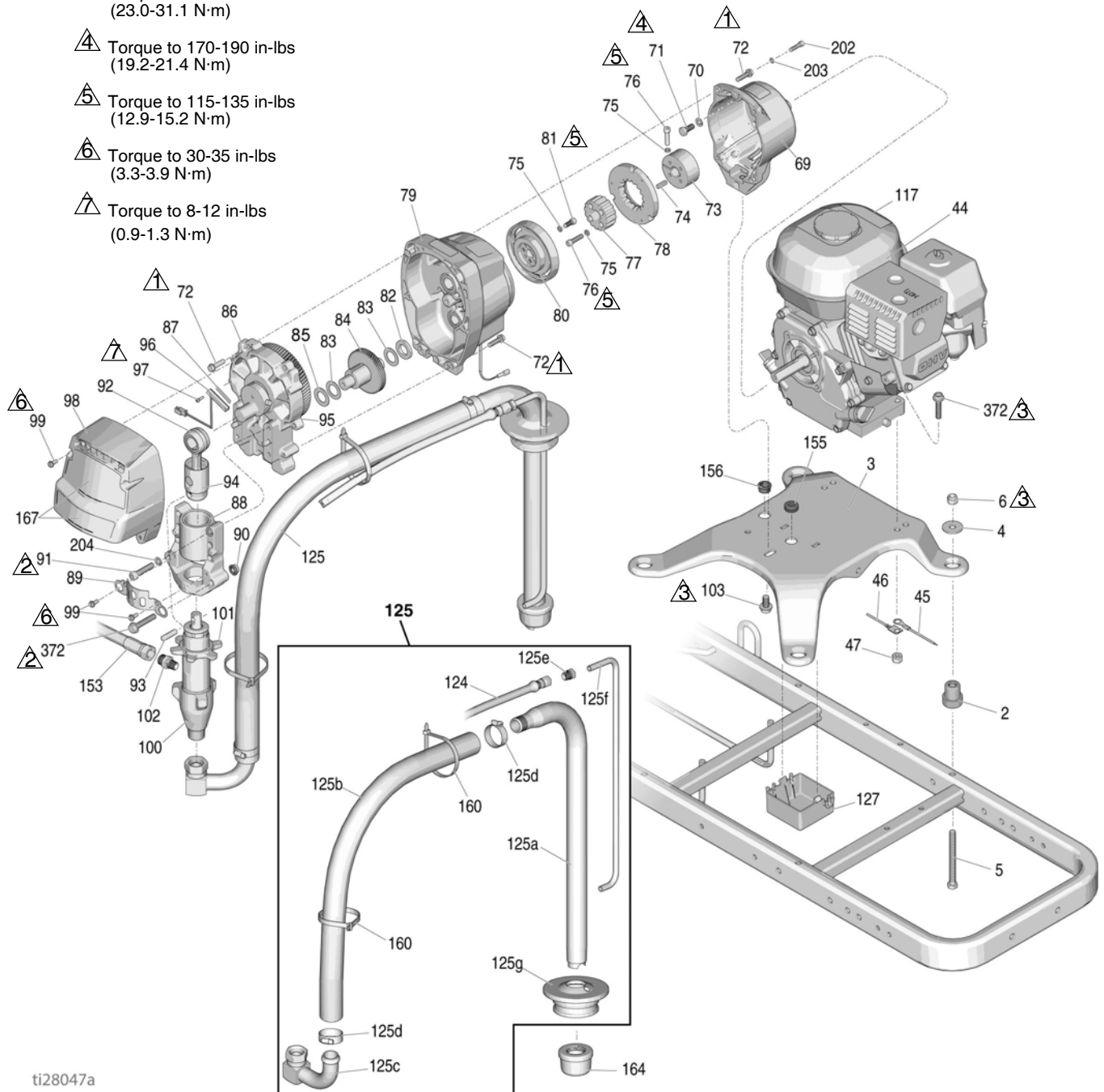

ti28047a



# Parts List

Ref	Part	Description	Qty	Ref	Part	Description	Qty
2	119695	DAMPENER, engine mount	4	92	287719	ROD, connecting, 3900 (includes 93, 94)	1
3	15F583	PLATE, engine mount	1		287720	ROD, connecting, 5900 (includes 93, 94)	1
4	108851	WASHER, plain	4	93	15F855	PIN, pump, 3900	1
5	113743	SCREW, cap, hex hd	4		15F856	PIN, pump, 5900	1
6	101566	NUT, lock	4	94	119676	SPRING, retaining, 3900	1
44	108879	ENGINE, gasoline, 4.0 hp, 3900	1		119778	SPRING, retaining, 5900	1
	114530	ENGINE, gasoline, 5.5 hp, 5900	1	95	116618	MAGNET	1
45	119579	CONDUCTOR, ground, 3900	1	96	119562	SWITCH, reed w/ connector	1
46	240997	CONDUCTOR, ground	1	97	114528	SCREW, mach, phillips, pnhd	2
47	110838	NUT, lock	2	98	16Y747	COVER, 3900 (includes 99)	1
69	15E535	HOUSING, clutch, machine, 3900	1		16Y748	COVER, 5900 (includes 99)	1
	15E277	HOUSING, clutch, machine, 5900	1	99	118444	SCREW, mach, slot hex wash hd	6
70	100214	WASHER	4	100	277069	PUMP, 3900	1
71	108842	SCREW, cap, hex hd	4		277070	PUMP, 5900	1
72	119426	SCREW, mach, hex washer hd, 3900	10	101	192723	NUT, retaining, 3900	1
	15C753	SCREW, mach, hex washer hd, 5900	6		193031	NUT, retaining, 5900	1
73	193680	COLLAR, shaft	1	102	196176	ADAPTER, nipple, 3900	1
74	183401	KEY, parallel	1		196178	ADAPTER, nipple, 5900	1
75	105510	WASHER, lock, spring (hi-collar)	10	103	112395	SCREW, cap, flng hd	1
76	108803	SCREW, hex, socket head	6	117	194126	LABEL, warning	1
77†		HUB, armature	1	124	245798	HOSE, coupled, 1/4"x7'	1
78†		ARMATURE, clutch, 4", 3900	1	125	24V567	HOSE, suction/drain	1
		ARMATURE, clutch, 5", 5900	1	125a	15F149	TUBE, suction	1
79	287463	KIT, pinion, housing, 3900	1	125b	185381	HOSE, nylon	1
	287465	KIT, pinion, housing, 5900	1	125c	110194	FITTING, union, swivel, 180°	1
80†		ROTOR, clutch, 4", 3900	1	125d	101818	CLAMP, hose	2
		ROTOR, clutch, 5", 5900	1	125e	196180	BUSHING	1
81	101682	SCREW, cap, sch	4	125f	16X071	TUBE, drain line	1
82	15F250	WASHER, thrust, 3900	1	125g	278722	GASKET	1
83	114699	WASHER, thrust, 3900	2	127	15F369	BOX	1
	114672	WASHER, 5900	1	153	245797	HOSE, coupled, 3/8 in. x 3	1
84	287653	GEAR, combination, 3900	1	155	114629	GROMMET, transducer	1
	287460	GEAR, combination, 5900	1	156	119569	BUSHING, strain relief	1
85	114672	WASHER, thrust	1	160	404989	STRAP, tie	2
86	287467	HOUSING, drive, 3900	1	164	181072	KIT, strainer	1
	287469	HOUSING, drive, 5900	1	167	17H686	LABEL, 3900	1
87	15F947	SHIELD, magnetic	1		17H687	LABEL, 5900	1
88	287714	HOUSING, bearing, 3900	1	203	104008	WASHER, 5900 only	4
	287715	HOUSING, bearing, 5900	1	202	102962	SCREW, 5900 only	4
89	15C762	SHIELD, pump rod	1	204	100214	WASHER, 3900	4
90	110996	NUT, hex, flange head	2		106115	WASHER, 5900	4
91	113467	SCREW, cap, socket hd, 3900	4	372	112960	SCREW	4
	114666	SCREW, cap, socket hd, 5900	4				

▲ Replacement warning labels may be ordered free of charge  
 † Included in Clutch Repair Kit 241109 (3900) and 241113 (5900)

# Parts Drawing - Drive and Pinion Housing Assemblies

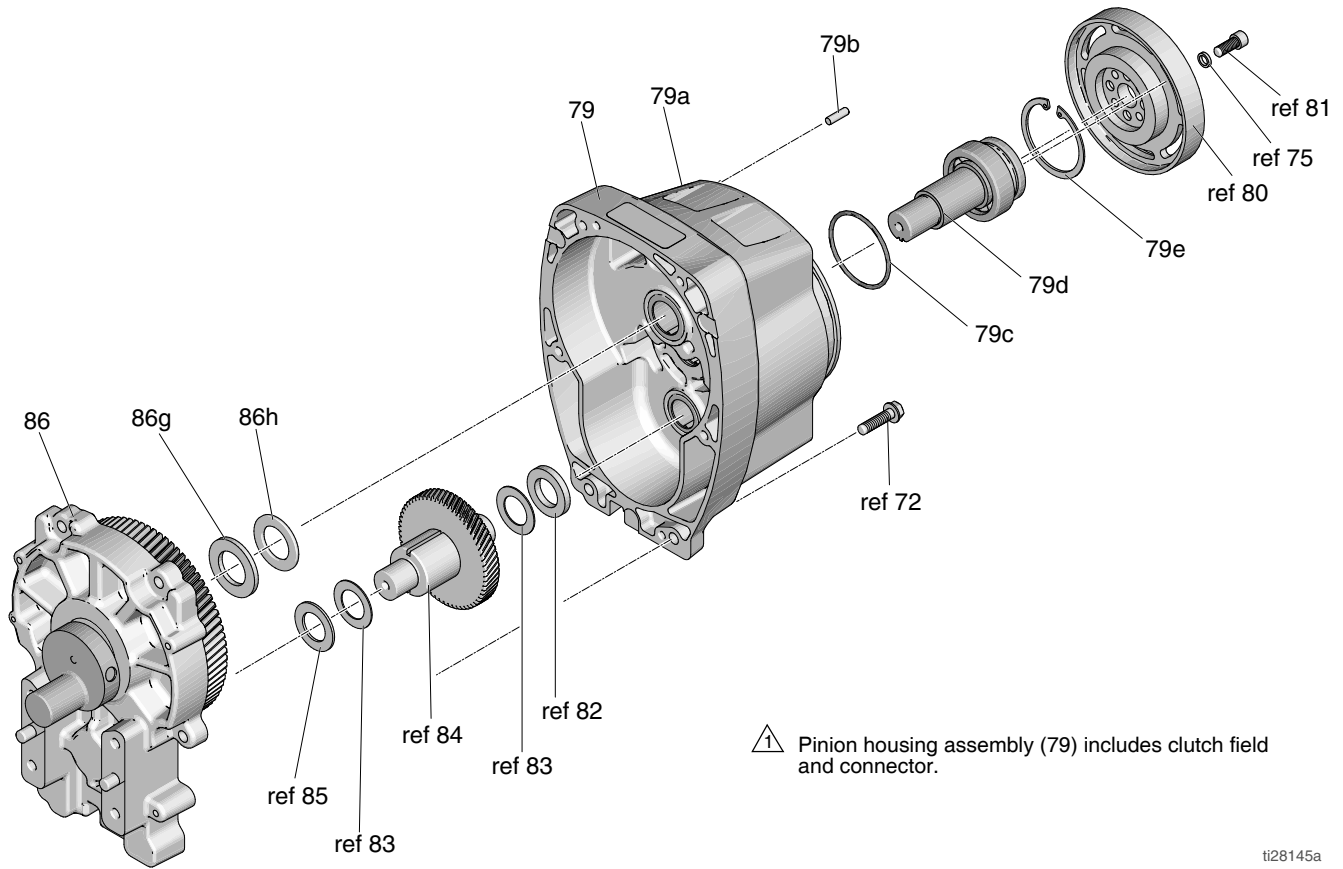

ti28145a

# Parts List

## Ref No. 86 and 79

**Ref No. 86:** Drive Housing Assembly 287467 for LineLazer V 3900; Drive Housing Assembly 287469 for LineLazer V 5900

Ref	Part	Description	Qty
86	287467	HOUSING, drive, 3900	1
	287469	HOUSING, drive, 5900	1
86g		WASHER	
	107089	LineLazer IV 3900	1
	194173	LineLazer IV 5900	1
86h		WASHER	
	116191	LineLazer IV 3900	1
	116192	LineLazer IV 5900	1

**Ref No. 79:** Pinion Housing Assembly 287463 for LineLazer V 3900; Pinion Housing Assembly 287465 for LineLazer V 5900

Ref	Part	Description	Qty
79	287463	HOUSING, pinion (3900)	1
	287465	HOUSING, pinion (5900)	1
79a		KIT, repair, coil	
	287474	LineLazer IV 3900	1
	287476	LineLazer IV 5900	1
79b	105489	PIN	2
79c		O-RING	
	165295	LineLazer IV 3900	1
	114683	LineLazer IV 5900	1
79d*		PINION SHAFT	
	241110	LineLazer IV 3900	1
	241114	LineLazer IV 5900	1
79e*		RETAINING RING, large	
	113094	LineLazer IV 3900	1
	112770	LineLazer IV 5900	1

\* Must be ordered separately.

# Parts Drawing - LineLazer V 3900, 5900

## Swivel Wheel Assembly & Filter

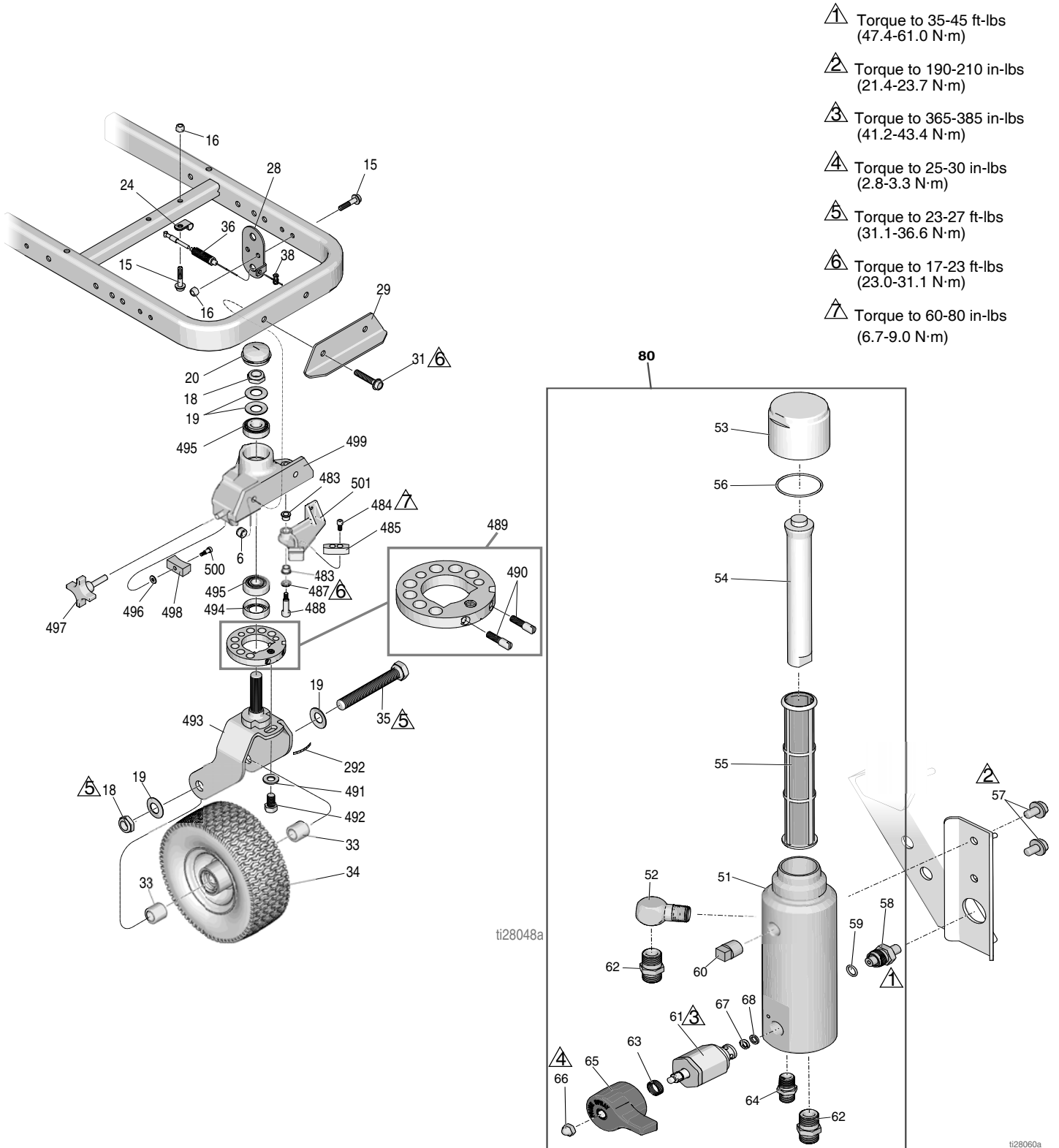

# Parts List

## Swivel Wheel Assembly

Ref	Part	Description	Qty
6	101566	NUT, lock	2
15	112960	SCREW, cap, flng hd	3
16	111040	NUT, lock, insert, nylon, 5/16	3
18*‡	112405	NUT, lock	2
19*‡	112825	WASHER	4
20*‡	114648	CAP, dust	1
24	108868	CLAMP, wire	1
28‡	15F910	BRACKET, cable	1
29	240991	BRACKET, caster, front	1
31	114982	SCREW, cap, flng hd	2
33*‡	193658	SPACER, seal	2
34*	114549	WHEEL, pneumatic	1
35*	113471	SCREW, cap, hex hd	1
36‡	241445	CABLE (includes 38)	1
38‡	114802	STOP, wire	1
292*‡	17H489	LABEL, disk adjustment	1
483*‡	114548	BEARING, bronze	2
484*‡	110754	SCREW, cap, sch	2
485*‡	193662	STOP, wedge	1
487*‡	15J603	SPACER, round	1
488*‡	120476	BOLT, shoulder	1
489*‡	17H486	DISK, adjuster, assembly	1
490*‡	17G762	SCREW, disk adjuster	2
491*‡	113962	WASHER	1
492*‡	114681	SCREW, cap, hex hd	1
493*‡	17H485	FORK	1
494*‡	113484	SEAL, grease	1
495*‡	113485	BEARING, cup/cone	2
496*‡	112776	WASHER, plain	1
497*‡	181818	KNOB, pronged	1
498*‡	193661	JAW	1
499*‡	15G952	CASTER	1
500*‡	108483	SCREW, shoulder	1
501*‡	193528	ARM, detent	1

\* Included in Swivel Wheel Repair Kit 240719

‡ Included in Swivel Wheel Repair Kit 241105

## Filter

Ref	Part	Description	Qty
51	17K166	MANIFOLD	1
52	196179	FITTING, elbow, street	1
53	287285	CAP, filter (includes 54, 56)	1
54	15C766	TUBE, diffusion	1
55	25A465	FILTER, fluid	1
56	117285	PACKING, o-ring	1
57	111801	SCREW, cap, hex hd	2
58	287172	KIT, repair, transducer	1
59	111457	O-RING	2
60	15G331	PLUG, pipe	2
61	245103	VALVE, drain, assy (includes 63, 65, 66, 67, 68)	1
62	196178	ADAPTER, nipple	1
63	114708	SPRING, compression	1
64	196181	FITTING, nipple	1
65	15G563	HANDLE, valve	1
66	116424	NUT, cap	1
67	193709	SEAT, valve	1
68	193710	SEAL, seat, valve	1
80	25A877	KIT, repair, filter, manifold	1

# Parts Drawing - LineLazer V 3900, 5900

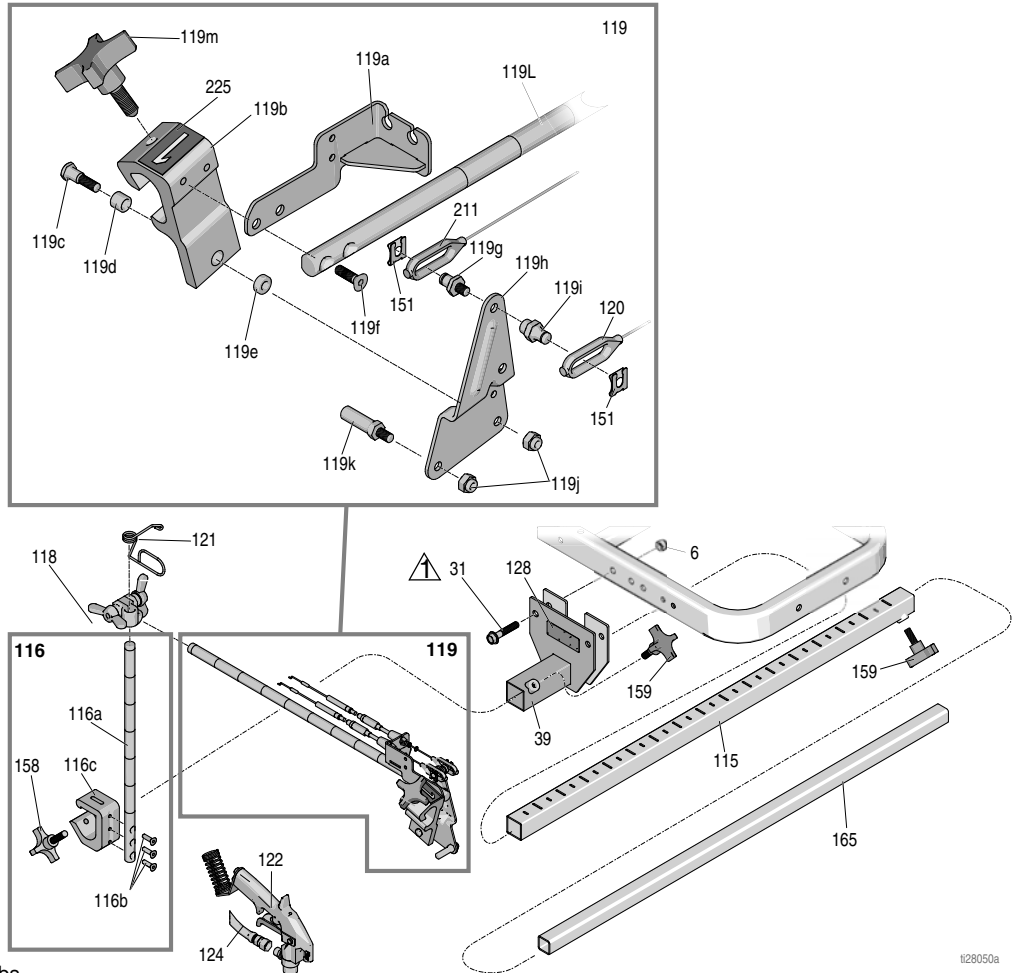

 Torque to 17-23 ft-lbs  
(23.0-31.1 N·m)

 Torque to 18-22 in-lbs  
(2.0-2.4 N·m)

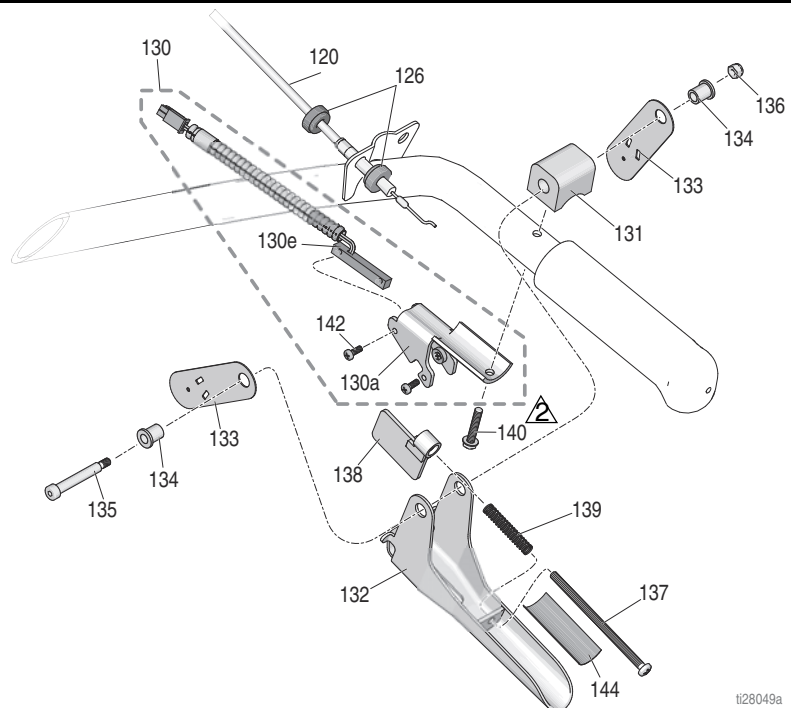

i128050a

i128049a

# Parts List

## Gun Holder and Arm

Ref	Part	Description	Qty
6	101566	NUT, lock	2
31	114982	SCREW, cap, flng hd	2
39	17H528	BRACKET, gun arm	1
115	17J407	ARM, extension, bar	1
116	17J424	BAR, height adjustment, assy	1
116a	17J139	BAR, gun, height, adjustment	1
116b	113428	SCREW, mach, hex, hd	3
116c	17J153	BRACKET, gun holder	1
118	24Y645	KIT, clamp, double wing nut	1
119	25A529	ARM, gun holder, linelazer (includes 151)	1
119a	24Y919	BRACKET, cable	1
119b*	15F216	HOLDER, gun	1
119c	17J575	FASTENER, special	1
119d*	119664	BEARING, sleeve	1
119e	17J576	SPACER, special	1
119f	119647	SCREW, cap, socket	2
119g	17H673	STUD, cable, gun	1
119h	15F214	LEVER, actuator	1
119i	17H674	ADAPTER, cable, gun	1
119j	102040	NUT, lock hex	2
119k	15F209	STUD, pull, trigger	1
119l	17J145	ARM, holder, gun	1
119m*	15F750	KNOB, holder, gun	1
120	25A488	CABLE, gun, manual (includes 126, 151)	1
121	188135	GUIDE, cable	1
122	248157	GUN, flex, basic	1
128▲	16P136	LABEL, safety, warning, iso	1
145	245733	KIT, repair, trigger handle (includes 132, 137, 138, 139)	1
151	126111	RETAINER, circlip, external, 8mm	2
158	108471	KNOB, pronged	1
159	111145	KNOB, pronged	2
165	17J408	ARM, extension, third gun	1
211	25A487	CABLE, gun, automatic (includes 151, 212, 213)	1
225	17C043	LABEL, number "1"	1
	17C046	LABEL, number "2"	1

\* Included in Gun Holder Repair Kit 287569

▲ Replacement Warning Labels may be ordered free of charge.

## Gun Trigger

Ref	Part	Description	Qty
120	25A488	CABLE, gun, manual (includes 126, 151)	1
124	245798	HOSE, coupled 1/4" x 7'	1
126	15F624	NUT, cable, gun (knurled)	2
130	25A636	BRACKET, trigger w switch	1
130a	276907	BRACKET, magnet	1
130e	17J237	SWITCH, reed	1
131	198896	BLOCK, mounting	1
132	245676	HANDLE	1
133	198895	PLATE, lever, pivot	2
134	111017	BEARING, flange	2
135	116941	SCREW, shoulder, skt hd	1
136	116969	NUT, lock	1
137	112381	SCREW, mach, pan head	1
138	117268	BRACKET, interrupter	1
139	117269	SPRING	1
140	128803	SCREW, thd forming, hex washer	1
142	117317	SCREW, plastine, pan head	2
144	17K587	LABEL, notice, adjustment	1

# Parts Drawing - LineLazer V 3900, 5900

<b>NOTICE</b>	
<p>Do not allow the solenoid wires to make a sharp bend as shown. Doing so may lead to wire breakage. Place an approximate 0.75" radius bend in the wires exiting the solenoid.</p>	

- Torque to 18-22 in-lbs (2.0-2.4 N-m)
- Torque to 130-150 in-lbs (14.6-16.9 N-m)
- Torque to 25-30 in-lbs (2.8-3.3 N-m)
- Torque to 28-32 in-lbs (2.8-3.3 N-m)
- Torque to 5-7 in-lbs (0.5-0.7 N-m)
- Torque to 65-75 in-lbs (7.3-8.4 N-m)

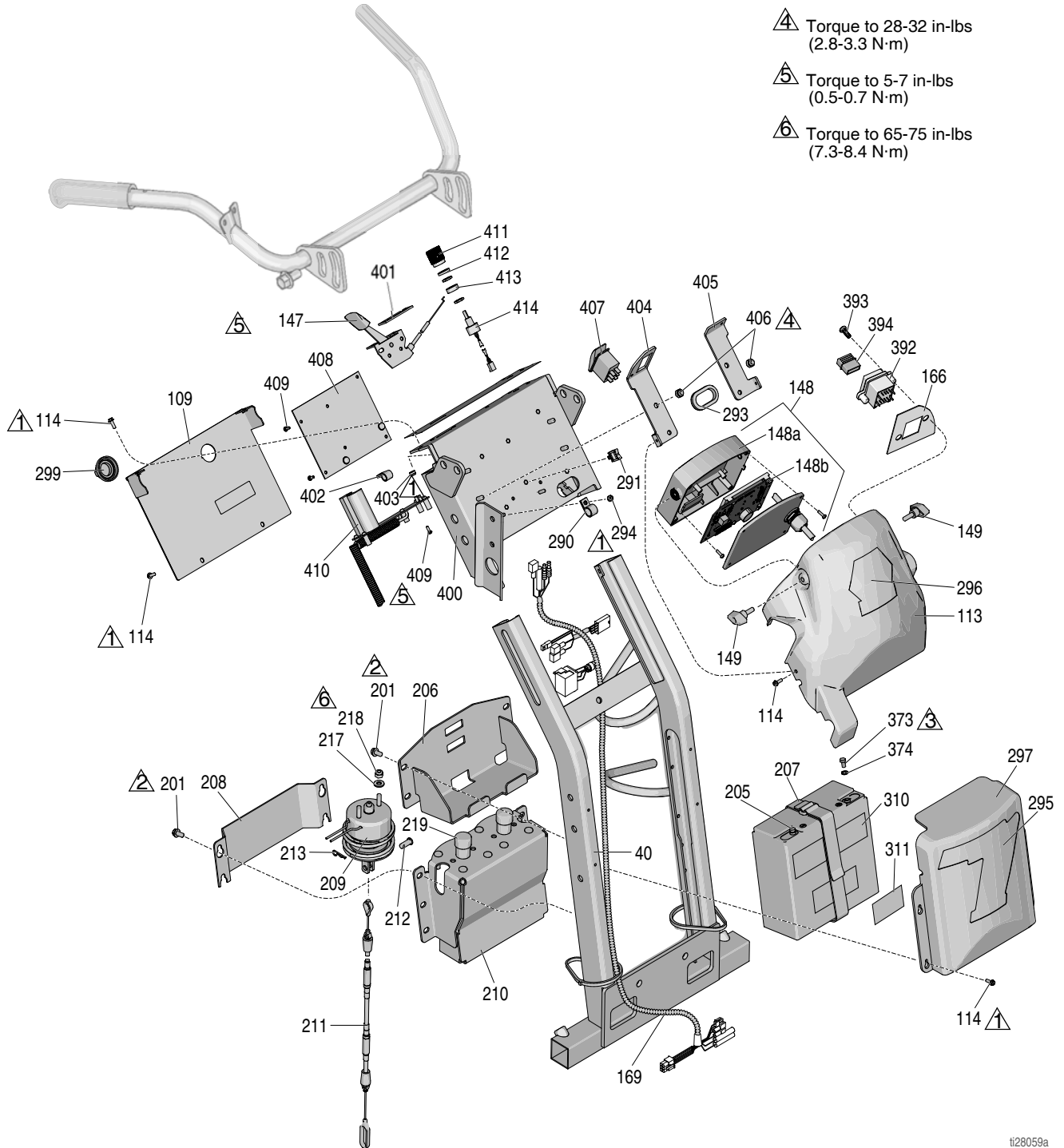

ti28059a



# Parts List

Ref	Part	Description	Qty	Ref	Part	Description	Qty
40	24Y665	FRAME, handle upright, painted	1	291	114687	CLIP, retainer	2
109	17J123	PLATE, cover	1	293	17H701	GROMMET, oval	1
113	17J135	COVER, control, painted (Series A)	1	294	115483	NUT, lock	2
	17V517	COVER, control, painted (Series B)	1	295	17K378	LABEL	1
114	128978	SCREW, mach, slot hex wash hd	12	296	17K379	LABEL	1
147	24Y643	CONTROL, throttle (includes 401, 402, 403)	1	297	17K377	COVER, battery, painted	1
148	25A498	BOX, control assembly complete (includes 149) (Series A)	1	299	17K310	PLUG, standard series	1
	17W550	BOX, control assembly complete (includes 149) (Series B)	1	310	17K397	LABEL	1
148a	25A497	KIT, repair, membrane switch	1	311	17K396	LABEL	1
148b	25A496	KIT, repair, display board (Series A)	1	373	128131	SCREW	2
	17W549	KIT, repair, display board (Series B)	1	374	111307	WASHER	2
149	16W408	KNOB, t-handle, 1/4-20 thd stud	2	392	25M792	BOARD, assembly	1
166	17V520	LABEL, usb	1	393	17V519	SCREW, pan hd	2
169	17J514	WIRE, harness	1	394	17V518	COVER, dust, usb	2
201*	107257	SCREW, thd forming	10	400	24Y642	CONTROL, plate	1
205*	24X370	BATTERY, 22 AH, sealed (includes 373, 374)	1	401	15F776	GASKET	1
206*	17H644	SHELF, battery	1	402	119736	CLAMP	1
207*	126949	STRAP, battery	1	403	111280	NUT	3
208*	17H650	COVER, solenoid	1	404	17J128	BRACKET	1
209*	25A486	KIT, solenoid (includes 212, 213, 217, 218, 219)	1	405	17J126	BRACKET	1
210*	24Y777	BRACKET	1	406	102040	NUT	4
211*	25A487	CABLE, auto (includes 212, 213, 151)	1	407	128783	SWITCH	1
212*	128711	PIN	1	408	25A493	KIT, main board, standard series (includes 409)	1
213*	15R598	CLIP	1		25A494	KIT, main board, hp auto series (includes 409)	1
217*	110755	WASHER	2	409	106520	SCREW	11
218*	121114	NUT	2	410*	25A495	KIT, charger board (includes 409)	1
219*	128712	CAP	2	411	116167	KNOB	1
290	128856	CLAMP, cable, nylon, 1/2"	2	412	15C973	GASKET	1
				413	198650	SPACER	1
				414	256219	POTENTIOMETER	1

\* HP Auto Series Only

# Distance Sensor Replacement

1. Remove wheel (17) from LineLazer.
2. Remove screw (25), wire clamp (24) and distance sensor (23).
3. Install new distance (23) with wire clamp (24) and screw (25).
4. Install wheel (17) on LineLazer.

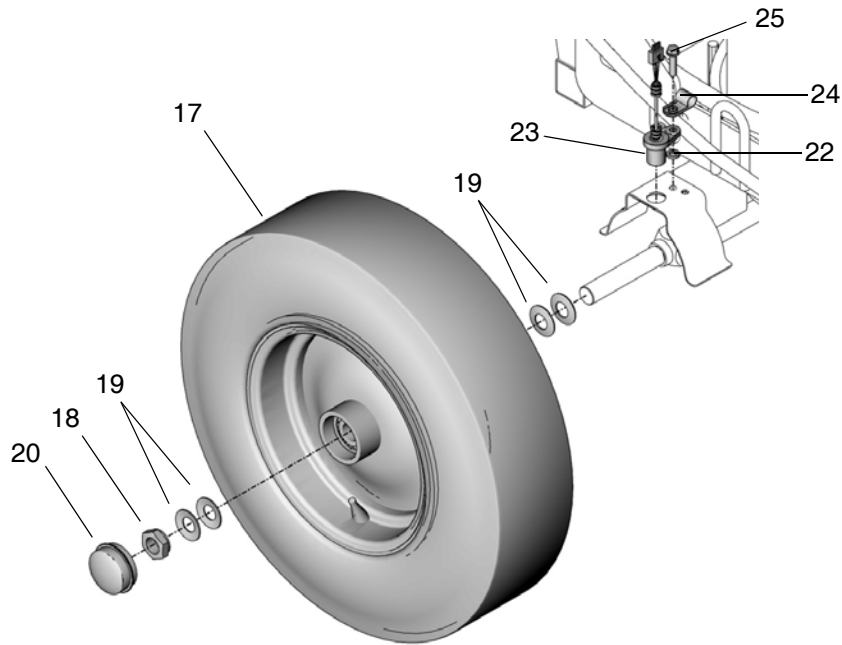



# Wiring Diagram (HP Auto Series)

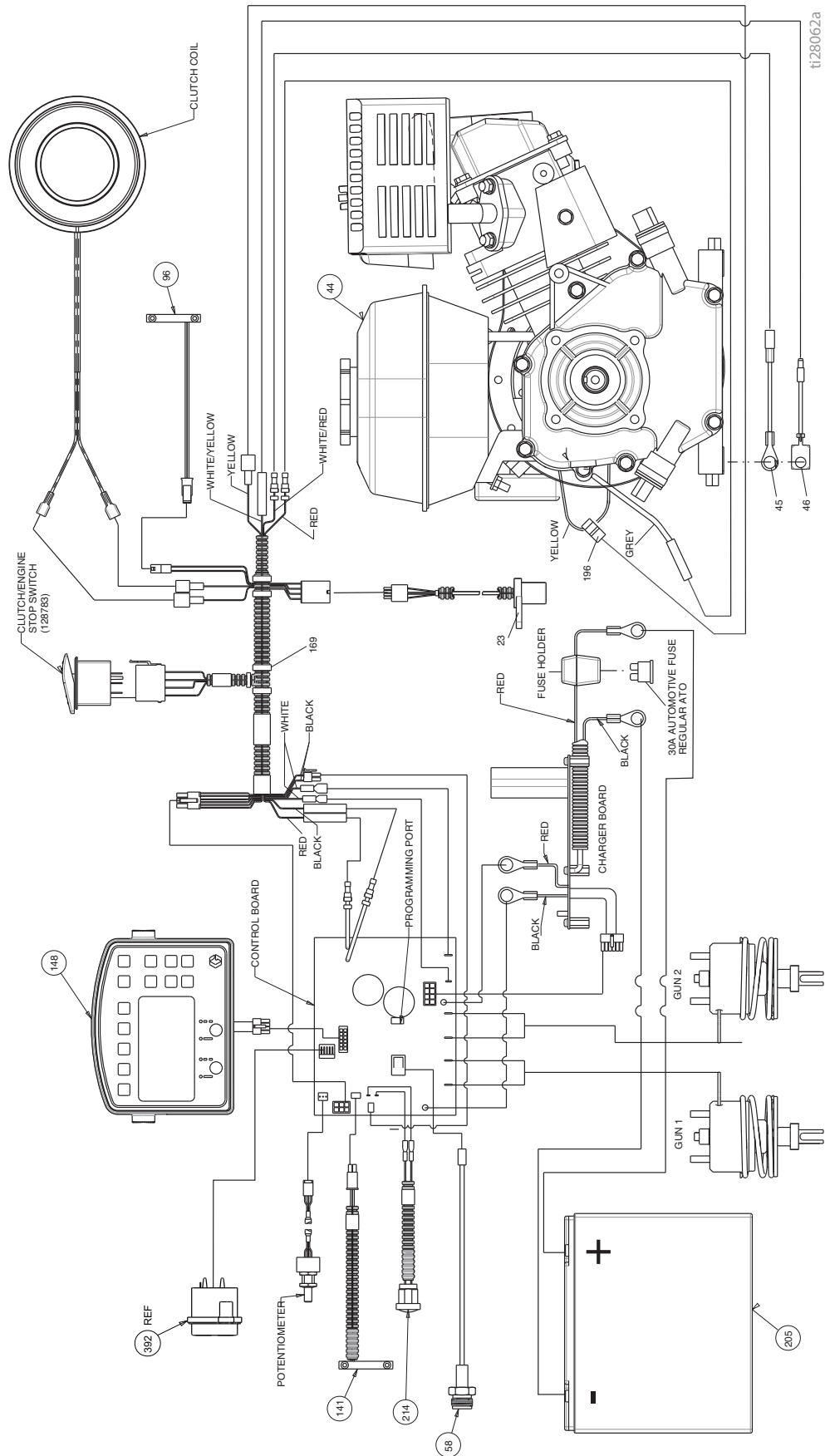

# Technical Data

LineLazer V 3900 Standard Series (Models 17H449, 17H450)		
	U.S.	Metric
<b>Dimensions</b>		
Height	Unpackaged - 44.5 in. Packaged - 52.5 in.	Unpackaged - 113.03 cm Packaged - 133.35 cm
Width	Unpackaged - 34.25 in. Packaged - 37.0 in.	Unpackaged - 86.99 cm Packaged - 93.98 cm
Length	Unpackaged - 68.75 in. Packaged - 73.5 in.	Unpackaged - 174.63 cm Packaged - 186.69 cm
Weight (dry - no paint)	Unpackaged - 230 lbs Packaged - 297 lbs	Unpackaged - 104 kg Packaged - 135 kg
<b>Noise (dBA)</b>		
Sound Power per ISO 9614:	95.6	
Sound Pressure per ISO 9614:	85.5	
<b>Vibration (m/s<sup>2</sup>) (8 hours daily exposure)</b>		
Hand Arm (per ISO 5349)	Left hand 3.73 Right hand 2.06	
Whole Body (per ISO 2631)	0.4	
<b>Power Rating (Horse Power)</b>		
Power Rating (Horse Power) per SAE J1349	4.0 HP @ 3600 rpm	2.9 kW @ 3600 rpm
Maximum Delivery	1.25 gpm	4.7 lpm
Maximum Tip Size		
1 gun	.036	
2 gun	.025	
Inlet paint strainer	16 mesh	1190 micron
Outlet paint strainer	50 mesh	297 micron
Pump inlet size	1 in. NSPM (m)	
Pump outlet size	3/8 NPT (f)	
Maximum working pressure	3300 psi	228 bar, 22.8 MPa
Electrical Capacity	50 W @ 3600 rpm	
Battery (optional)	12V, 22Ah, Sealed lead acid, Deep cycle	

Wetted Parts: PTFE, Nylon, polyurethane, V-Max, UHMWPE, fluoroelastomer, acetal, leather, tungsten carbide, stainless steel, chrome plating, nickel-plated carbon steel, ceramic

<b>LineLazer V 5900 Standard Series (Models 17H454, 17H455)</b>		
	<b>U.S.</b>	<b>Metric</b>
<b>Dimensions</b>		
Height (with handle bar down)	Unpackaged - 44.5 in. Packaged - 52.5 in.	Unpackaged - 113.03 cm Packaged - 133.35 cm
Width	Unpackaged - 34.25 in. Packaged - 37.0 in.	Unpackaged - 86.99 cm Packaged - 93.98 cm
Length (with platform down)	Unpackaged - 68.75 in. Packaged - 73.50 in.	Unpackaged - 174.63 cm Packaged - 186.69 cm
Weight (dry - no paint)	Unpackaged - 250 lbs Packaged - 317 lbs	Unpackaged - 113 kg Packaged - 144 kg
<b>Noise (dBa)</b>		
Sound Power per ISO 9614:	97.6	
Sound Pressure per ISO 9614:	87.1	
<b>Vibration (m/s<sup>2</sup>) (8 hours daily exposure)</b>		
Hand Arm (per ISO 5349)	Left hand 3.65 Right hand 3.72	
Whole Body (per ISO 2631)	0.4	
<b>Power Rating (Horse Power)</b>		
Power Rating (Horse Power) per SAE J1349	5.5 HP @ 3600 rpm	4.1 kW @ 3600 rpm
Maximum Delivery	1.6 gpm	6.0 lpm
Maximum Tip Size		
1 gun	.043	
2 gun	.029	
Inlet paint strainer	16 mesh	1190 micron
Outlet paint strainer	50 mesh	297 micron
Pump inlet size	1 in. NSPM (m)	
Pump outlet size	3/8 NPT (f)	
Maximum working pressure	3300 psi	228 bar, 22.8 MPa
Electrical Capacity	84 W @ 3600 rpm	
Battery	12V, 22Ah, Sealed lead acid, Deep cycle	

Wetted Parts: PTFE, Nylon, polyurethane, V-Max, UHMWPE, fluoroelastomer, acetal, leather, tungsten carbide, stainless steel, chrome plating, nickel-plated carbon steel, ceramic

<b>LineLazer V 3900 HP Auto Series (Models 17K577, 17H451, 17K638, 17H452, 17K579, 17H453)</b>		
	<b>U.S.</b>	<b>Metric</b>
<b>Dimensions</b>		
Height (with handle bar down)	Unpackaged - 44.5 in. Packaged - 52.5 in.	Unpackaged - 113.03 cm Packaged - 133.35 cm
Width	Unpackaged - 34.25 in. Packaged - 37.0 in.	Unpackaged - 86.99 cm Packaged - 93.98 cm
Length (with platform down)	Unpackaged - 68.75 in. Packaged - 73.50 in.	Unpackaged - 174.63 cm Packaged - 186.69 cm
Weight (dry - no paint)	Unpackaged - 240 lbs Packaged - 307 lbs	Unpackaged - 109 kg Packaged - 139 kg
<b>Noise (dBa)</b>		
Sound Power per ISO 9614:	95.6	
Sound Pressure per ISO 9614:	85.5	
<b>Vibration (m/s<sup>2</sup>) (8 hours daily exposure)</b>		
Hand Arm (per ISO 5349)	Left hand 3.73 Right hand 2.06	
Whole Body (per ISO 2631)	0.4	
<b>Power Rating (Horse Power)</b>		
Power Rating (Horse Power) per SAE J1349	4.0 HP @ 3600 rpm	2.9 kW @ 3600 rpm
Maximum Delivery	1.25 gpm	4.7 lpm
Maximum Tip Size 1 gun 2 gun	.036 .025	
Inlet paint strainer	16 mesh	1190 micron
Outlet paint strainer	50 mesh	297 micron
Pump inlet size	1 in. NSPM (m)	
Pump outlet size	3/8 NPT (f)	
Maximum working pressure	3300 psi	228 bar, 22.8 MPa
Electrical Capacity	50 W @ 3600 rpm	
Starting Battery	12V, 22Ah, Sealed lead acid, Deep cycle	

Wetted Parts: PTFE, Nylon, polyurethane, V-Max, UHMWPE, fluoroelastomer, acetal, leather, tungsten carbide, stainless steel, chrome plating, nickel-plated carbon steel, ceramic

<b>LineLazer V 5900 HP Auto Series (Models 17K580, 17H456, 17K636, 17H457, 17K581, 17H458)</b>		
	<b>U.S.</b>	<b>Metric</b>
<b>Dimensions</b>		
Height (with handle bar down)	Unpackaged - 44.5 in. Packaged - 52.5 in.	Unpackaged - 113.03 cm Packaged - 133.35 cm
Width	Unpackaged - 34.25 in. Packaged - 37.0 in.	Unpackaged - 86.99 cm Packaged - 93.98 cm
Length (with platform down)	Unpackaged - 68.75 in. Packaged - 73.50 in.	Unpackaged - 174.63 cm Packaged - 186.69 cm
Weight (dry - no paint)	Unpackaged - 266 lbs Packaged - 333 lbs	Unpackaged - 121 kg Packaged - 151 kg
<b>Noise (dBa)</b>		
Sound Power per ISO 9614:	97.6	
Sound Pressure per ISO 9614:	87.1	
<b>Vibration (m/s<sup>2</sup>) (8 hours daily exposure)</b>		
Hand Arm (per ISO 5349)	Left hand 3.65 Right hand 3.72	
Whole Body (per ISO 2631)	0.4	
<b>Power Rating (Horse Power)</b>		
Power Rating (Horse Power) per SAE J1349	5.5 HP @ 3600 rpm	4.1 kW @ 3600 rpm
Maximum Delivery	1.6 gpm	6.0 lpm
Maximum Tip Size		
1 gun	.043	
2 gun	.029	
Inlet paint strainer	16 mesh	1190 micron
Outlet paint strainer	50 mesh	297 micron
Pump inlet size	1 in. NSPM (m)	
Pump outlet size	3/8 NPT (f)	
Maximum working pressure	3300 psi	228 bar, 22.8 MPa
Electrical Capacity	84 W @ 3600 rpm	
Starting Battery	12V, 22Ah, Sealed lead acid, Deep cycle	

Wetted Parts: PTFE, Nylon, polyurethane, V-Max, UHMWPE, fluoroelastomer, acetal, leather, tungsten carbide, stainless steel, chrome plating, nickel-plated carbon steel, ceramic



# Notes

# Graco Standard Warranty

Graco warrants all equipment referenced in this document which is manufactured by Graco and bearing its name to be free from defects in material and workmanship on the date of sale to the original purchaser for use. With the exception of any special, extended, or limited warranty published by Graco, Graco will, for a period of twelve months from the date of sale, repair or replace any part of the equipment determined by Graco to be defective. This warranty applies only when the equipment is installed, operated and maintained in accordance with Graco's written recommendations.

This warranty does not cover, and Graco shall not be liable for general wear and tear, or any malfunction, damage or wear caused by faulty installation, misapplication, abrasion, corrosion, inadequate or improper maintenance, negligence, accident, tampering, or substitution of non-Graco component parts. Nor shall Graco be liable for malfunction, damage or wear caused by the incompatibility of Graco equipment with structures, accessories, equipment or materials not supplied by Graco, or the improper design, manufacture, installation, operation or maintenance of structures, accessories, equipment or materials not supplied by Graco.

This warranty is conditioned upon the prepaid return of the equipment claimed to be defective to an authorized Graco distributor for verification of the claimed defect. If the claimed defect is verified, Graco will repair or replace free of charge any defective parts. The equipment will be returned to the original purchaser transportation prepaid. If inspection of the equipment does not disclose any defect in material or workmanship, repairs will be made at a reasonable charge, which charges may include the costs of parts, labor, and transportation.

**THIS WARRANTY IS EXCLUSIVE, AND IS IN LIEU OF ANY OTHER WARRANTIES, EXPRESS OR IMPLIED, INCLUDING BUT NOT LIMITED TO WARRANTY OF MERCHANTABILITY OR WARRANTY OF FITNESS FOR A PARTICULAR PURPOSE.**

Graco's sole obligation and buyer's sole remedy for any breach of warranty shall be as set forth above. The buyer agrees that no other remedy (including, but not limited to, incidental or consequential damages for lost profits, lost sales, injury to person or property, or any other incidental or consequential loss) shall be available. Any action for breach of warranty must be brought within two (2) years of the date of sale.

**GRACO MAKES NO WARRANTY, AND DISCLAIMS ALL IMPLIED WARRANTIES OF MERCHANTABILITY AND FITNESS FOR A PARTICULAR PURPOSE, IN CONNECTION WITH ACCESSORIES, EQUIPMENT, MATERIALS OR COMPONENTS SOLD BUT NOT MANUFACTURED BY GRACO.** These items sold, but not manufactured by Graco (such as electric motors, switches, hose, etc.), are subject to the warranty, if any, of their manufacturer. Graco will provide purchaser with reasonable assistance in making any claim for breach of these warranties.

In no event will Graco be liable for indirect, incidental, special or consequential damages resulting from Graco supplying equipment hereunder, or the furnishing, performance, or use of any products or other goods sold hereto, whether due to a breach of contract, breach of warranty, the negligence of Graco, or otherwise.

## **FOR GRACO CANADA CUSTOMERS**

The Parties acknowledge that they have required that the present document, as well as all documents, notices and legal proceedings entered into, given or instituted pursuant hereto or relating directly or indirectly hereto, be drawn up in English. Les parties reconnaissent avoir convenu que la rédaction du présente document sera en Anglais, ainsi que tous documents, avis et procédures judiciaires exécutés, donnés ou intentés, à la suite de ou en rapport, directement ou indirectement, avec les procédures concernées.

## **POUR LES CLIENTS DE GRACO PARLANT FRANCAIS**

Les parties reconnaissent avoir convenu que la rédaction du présent document ainsi que de tous les documents, avis et procédures judiciaires exécutés, donnés ou intentés à la suite de ou en rapport, directement ou indirectement, avec les procédures concernées, sera en anglais.

## **ADDITIONAL WARRANTY COVERAGE**

Graco does provide extended warranty and wear warranty for products described in the "Graco Contractor Equipment Warranty Program".

# Graco Information

For the latest information about Graco products, visit [www.graco.com](http://www.graco.com).

For patent information, see [www.graco.com/patents](http://www.graco.com/patents).

**TO PLACE AN ORDER**, contact your Graco distributor or call 1-800-690-2894 to identify the nearest distributor.

*All written and visual data contained in this document reflects the latest product information available at the time of publication.  
Graco reserves the right to make changes at any time without notice.*

Original instructions. This manual contains English. MM 3A3389

**Graco Headquarters:** Minneapolis

**International Offices:** Belgium, China, Japan, Korea

**GRACO INC. AND SUBSIDIARIES • P.O. BOX 1441 • MINNEAPOLIS MN 55440-1441 • USA**  
**Copyright 2016, Graco Inc. All Graco manufacturing locations are registered to ISO 9001.**

[www.graco.com](http://www.graco.com)

Revision D, June 2018