

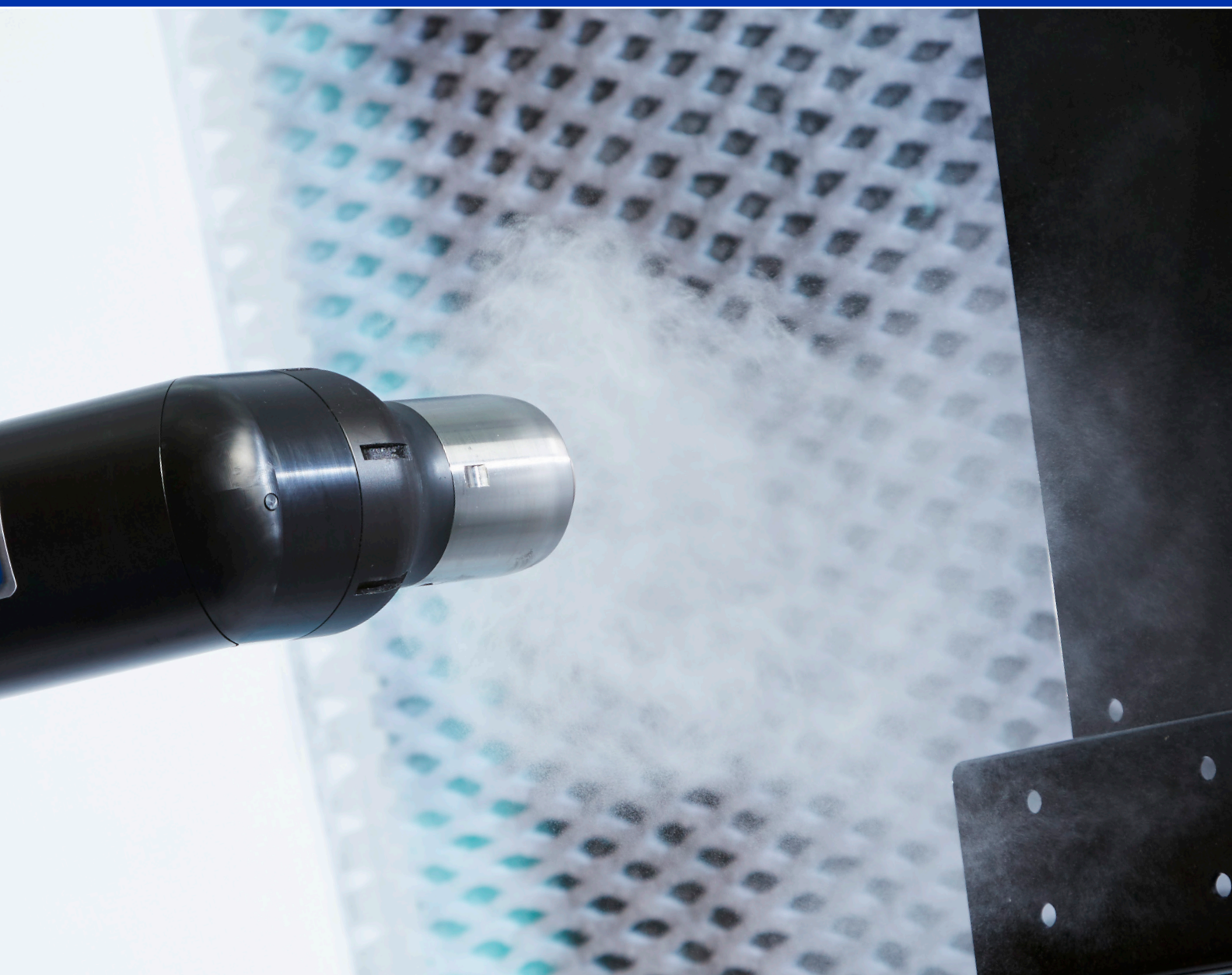

# ProBell<sup>®</sup> Rotary Applicator

High Performance Rotary Bell Atomizer System



PROVEN QUALITY. LEADING TECHNOLOGY.



# High Performance, Scalable System

Graco's new ProBell rotary atomizer offers high performance spraying with intuitive controls and a scalable design. By giving you the flexibility to start small with one controller or install a complete system all at once, accommodating your specific installation and budget has never been easier. The ProBell is also precision balanced for low vibration up to 60,000 RPM's – allowing you to achieve high production speeds for your industrial application.



In addition to delivering superior quality, high transfer efficiency and precision spraying, the ProBell applicator is lightweight and compact for lower payload robots or reciprocators.

Available in two versatile styles, the ProBell has a standard model for solid wrist robot, reciprocator or fixed mount. While the hollow wrist robot model makes maintenance easy with a quick disconnect plate that allows you to remove the applicator from the robot without touching hose connections.



SOLID WRIST ROBOT

HOLLOW WRIST ROBOT

RECIPROCATOR OR FIXED MOUNT

## Scalable

Modularity allows customers to design a system to meet their production needs and budget – big or small

Choose up to 4 controllers to improve spray performance and data management

## Simple Installation

Easy system integration with existing PLC or new installation

## User-Friendly Controls

Controller interface allows for easy management of spray parameters

## Durable & Safe

Improved safety and reliability with a low voltage cable and adjustable arc detection settings

## Optimized Spray Performance

Dual shaping air and bell cup design for superior atomization



# Designed for Performance

The ProBell provides the highest spray performance and transfer efficiency thanks to our dual shaping air and bell cups. Each applicator delivers superior quality, precision spraying with uniform atomization and an easily adjustable spray pattern for the most demanding finishing applications. All components are made of high quality, durable materials for safe, trouble-free operation.

## FLEXIBLE

- Lightweight hollow wrist robot model is only 13.5 lbs with the standard model lighter (9 lbs)
- Compact size and small diameter allow for spraying in tight spaces
- Mounting styles: hollow wrist robot, solid wrist robot, fixed or reciprocator mount

## EASY TO SERVICE

- Hollow wrist robot model connects hoses with a quick disconnect plate
- Removable shroud allows for access to key components
- Few parts for quick and easy maintenance

## SAFE

- 100 kV power supply with a low voltage cable connection improves safety while reducing system complexity
- Arc detection shuts off electrostatics to ensure a safe environment

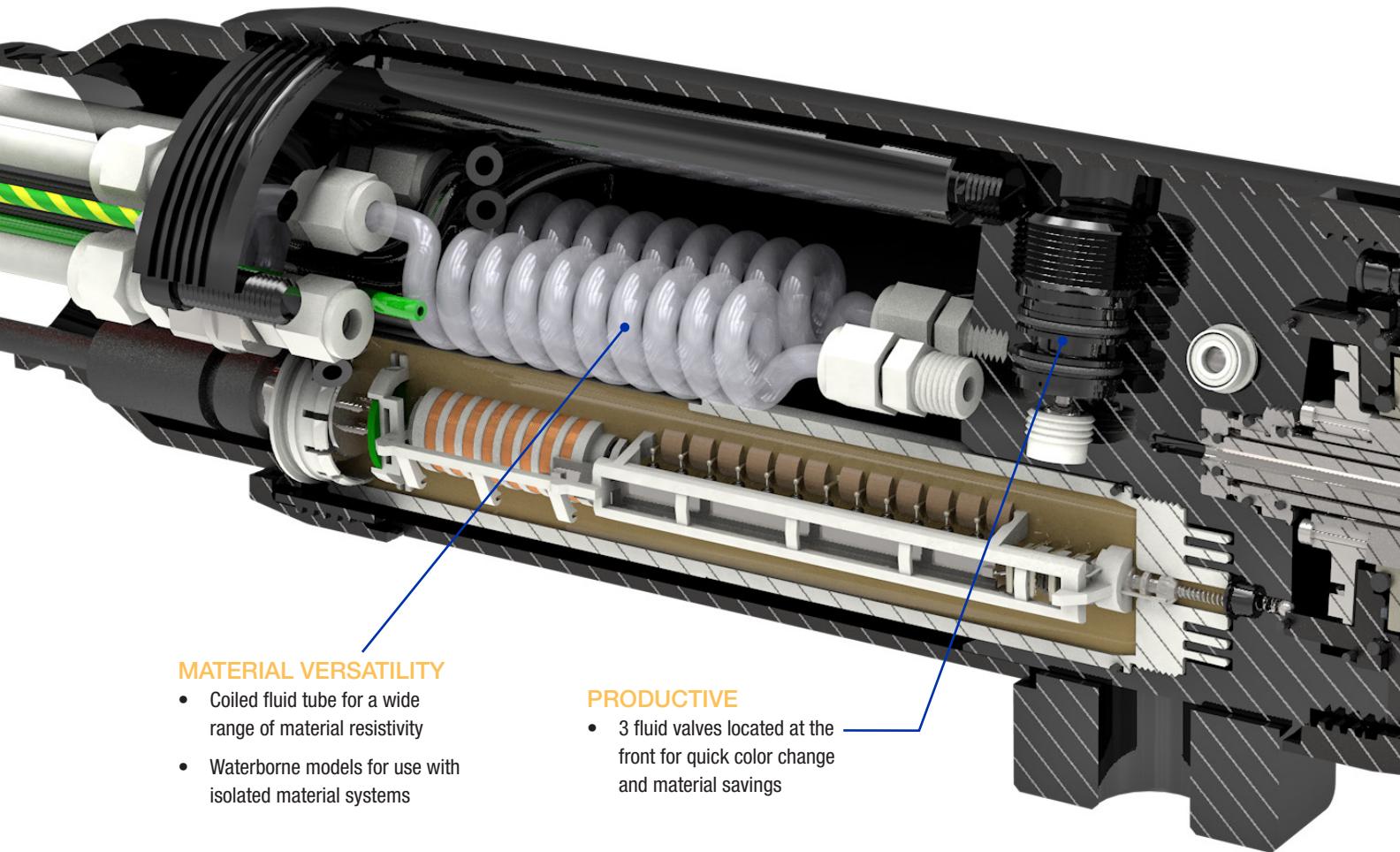

## MATERIAL VERSATILITY

- Coiled fluid tube for a wide range of material resistivity
- Waterborne models for use with isolated material systems

## PRODUCTIVE

- 3 fluid valves located at the front for quick color change and material savings

up to 60,000 RPM  
Precision balanced for low vibration  
and high production speeds

# Better Pattern Shape. Better Transfer Efficiency.

Dual shaping air improves pattern shape and transfer efficiency for better overall finish quality.

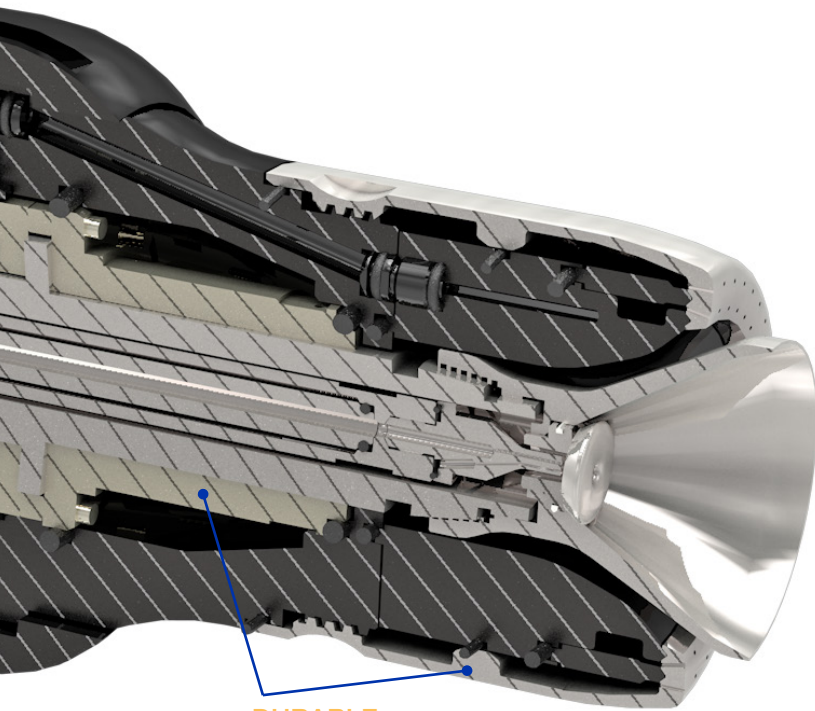
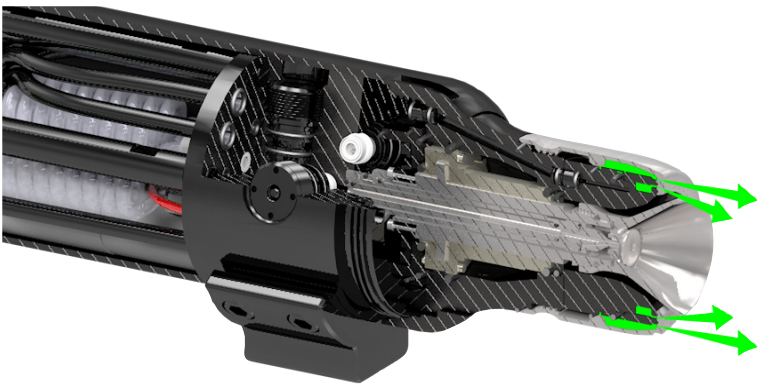

## DURABLE

- Stainless steel air cap cover protects bell cup and air cap
- Air bearing has no parts to wear out
- Turbine assembly is a proven design

# Precision Bell Cups

Bell cups are optimized for superior spraying with a variety of pattern sizes and flow rates. Available in 2 different aluminum finishes (including high wear for abrasive materials) or composite construction.

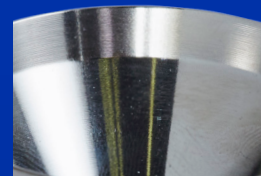

## SMOOTH BELL CUP

The smooth edge cup has optimum durability and works well for many metallics.

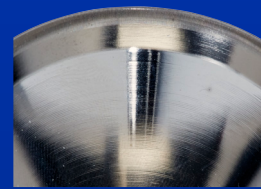

## SERRATED BELL CUP

Because the serrated cup edge has equally spaced axial grooves that act as channels for paint flow, it provides better atomization and uniform particles. This makes it ideal for difficult to atomize paint and clear coats.

# Certification



## BELL CUP CERTIFICATION

Every bell cup is tested and delivered with a certificate indicating the spray pattern size and precision balanced cup meet stringent Graco requirements so you can be assured a quality product.



# Think Big. Start Small.

## Easily Expand your Control Options

Not everyone has the need or budget for a fully-decked out system. Graco's unique approach to rotary atomizers makes it easier for you to get exactly what you need without breaking the bank. The scalable design allows you to start small with 1 controller and work your way up to 4 to further improve performance and data management. These user-friendly controls are easy to learn and operate.



ELECTROSTATIC CONTROLLER

### Electrostatic Controller

Precise control is critical to your rotary atomizer application. Our electrostatic controller keeps you connected to what's going on every minute of every day, detects unsafe electrostatic conditions and allows you to change parameters on the fly to improve performance.

- Voltage and current can be independently adjusted to meet specific manufacturing requirements
- Full system integration with PLC or switch box control
- Improves safety by automatically shutting off electrostatics when the part is too close to the gun



MANUAL AIR CONTROLLER

### Speed Controller

- Precise management of turbine speed for superior material atomization
- A magnetic speed reader in the bell provides reliable communication
- System logic controller provides user friendly operation



SPEED CONTROLLER

### Air Controller

- Electronic Model: Precision operation and communication for all air controls
- Manual Model: Individual regulators for air control



## System Logic Controller

The key to the System Logic Controller is its ability to control and manage your ProBell with the touch of a button.

- User friendly operation of all system functions
- Eliminate guesswork with maintenance reminders and system logs
- Runs two ProBell applicators from one controller
- Provides one centralized control of ProBell and fluid management when used with ProMix PD2K Integrated proportioner

With 99 presets, the shaping airs, bell rotational speed, and electrostatics can be precisely set for various part configurations.



Intuitive controls allow for simple operation of spray function, such as cup wash, purging, and flushing.



One screen shows exactly how your ProBell is functioning — spraying and electrostatics.

# Ordering Information

Choose a pre-configured system, and you'll get all the components you need – the applicator, hoses and controllers. Or build a custom system that is as unique as your application. Whatever you choose, Graco has you covered.

All systems are built on a cart with hoses and lines connected to the mounted controllers. Once the system arrives at your facility, simply position the cart booth side, mount the ProBell applicator and connect lines to the ProBell and fluid source. Installation made easy!

## Select a Pre-Configured System

With this option, it only takes one part number to order a complete ProBell system. Simply find the system and part number that best matches your requirements.

**Solventborne ProBell Systems include:** applicator, 20 meter (65ft) hose bundle, cart with electrostatic controller, speed controller, electronic air controller, system logic controller, and filtration system.

SOLVENTBORNE SYSTEMS				Standard Bell Applicator Systems			
Hollow Wrist Robot Applicator Systems				Standard Bell Applicator Systems			
SYSTEM PART NO.	BELL CUP SIZE	NOZZLE SIZE	APPLICATOR PART NO.	SYSTEM PART NO.	BELL CUP SIZE	NOZZLE SIZE	APPLICATOR PART NO.
P1A230	15 mm	0.75 mm	R1A230	P1A130	15 mm	0.75 mm	R1A130
P1A240	15 mm	1.0 mm	R1A240	P1A140	15 mm	1.0 mm	R1A140
P1A250	15 mm	1.25 mm	R1A250	P1A150	15 mm	1.25 mm	R1A150
P3A230	30 mm	0.75 mm	R3A230	P3A130	30 mm	0.75 mm	R3A130
P3A240	30 mm	1.0 mm	R3A240	P3A140	30 mm	1.0 mm	R3A140
P3A250	30 mm	1.25 mm	R3A250	P3A150	30 mm	1.25 mm	R3A150
P3A260	30 mm	1.5 mm	R3A260	P3A160	30 mm	1.5 mm	R3A160
P5A240	50 mm	1.0 mm	R5A240	P5A140	50 mm	1.0 mm	R5A140
P5A250	50 mm	1.25 mm	R5A250	P5A150	50 mm	1.25 mm	R5A150
P5A260	50 mm	1.5 mm	R5A260	P5A160	50 mm	1.5 mm	R5A160

**Waterborne ProBell Systems include:** applicator, 20 meter (65ft) hose bundle, cart with electrostatic controller, speed controller, electronic air controller, system logic controller, and filtration system. Waterborne ProBell System hose bundles do not include paint, dump, or solvent fluid lines.

WATERBORNE SYSTEMS				Standard Bell Applicator Systems			
Hollow Wrist Robot Applicator Systems				Standard Bell Applicator Systems			
SYSTEM PART NO.	BELL CUP SIZE	NOZZLE SIZE	APPLICATOR PART NO.	SYSTEM PART NO.	BELL CUP SIZE	NOZZLE SIZE	APPLICATOR PART NO.
P1A238	15 mm	0.75 mm	R1A238	P1A138	15 mm	0.75 mm	R1A138
P1A248	15 mm	1.0 mm	R1A248	P1A148	15 mm	1.0 mm	R1A148
P1A258	15 mm	1.25 mm	R1A258	P1A158	15 mm	1.25 mm	R1A158
P3A238	30 mm	0.75 mm	R3A238	P3A138	30 mm	0.75 mm	R3A138
P3A248	30 mm	1.0 mm	R3A248	P3A148	30 mm	1.0 mm	R3A148
P3A258	30 mm	1.25 mm	R3A258	P3A158	30 mm	1.25 mm	R3A158
P3A268	30 mm	1.5 mm	R3A268	P3A168	30 mm	1.5 mm	R3A168
P5A248	50 mm	1.0 mm	R5A248	P5A148	50 mm	1.0 mm	R5A148
P5A258	50 mm	1.25 mm	R5A258	P5A158	50 mm	1.25 mm	R5A158
P5A268	50 mm	1.5 mm	R5A268	P5A168	50 mm	1.5 mm	R5A168



# Or Design a Custom System



## 1 Choose Controllers

CONTROLLERS	
PART NO.	CONTROLLER
24Z261	Control Cart with Electrostatic Controller, Solventborne, Speed Controller, Electronic Air Controller, System Logic Controller and Air Filtration
24Z717	Control Cart with Electrostatic Controller, Waterborne, Speed Controller, Electronic Air Controller, System Logic Controller and Air Filtration
24Z098	Electrostatic Controller, Solventborne Includes Power Supply Cord and I/O Cable
24Z099	Electrostatic Controller, Waterborne Includes Power Supply Cord and I/O Cable
24Z219	Speed Controller with System Logic Controller, Power Supply and CAN cables
24Z220	Speed Controller
24Z221	Manual Air Controller
24Z222	Electronic Air Controller
24Z223	System Logic Controller
25C822	Air Filtration Kit



SOLID WRIST ROBOT



RECIPROCATOR OR FIXED MOUNT



HOLLOW WRIST ROBOT

## 2 Choose an Applicator

SOLVENTBORNE		
Hollow Wrist Robot Applicator Models		
PART NO.	BELL CUP SIZE*	NOZZLE SIZE
R5A240	50 mm	1.0 mm
R5A250	50 mm	1.25 mm
R5A260	50 mm	1.5 mm
R3A230	30 mm	0.75 mm
R3A240	30 mm	1.0 mm
R3A250	30 mm	1.25 mm
R3A260	30 mm	1.5 mm
R1A230	15 mm	0.75 mm
R1A240	15 mm	1.0 mm
R1A250	15 mm	1.25 mm

WATERBORNE		
Hollow Wrist Robot Applicator Models		
PART NO.	BELL CUP SIZE*	NOZZLE SIZE
R5A248	50 mm	1.0 mm
R5A258	50 mm	1.25 mm
R5A268	50 mm	1.5 mm
R3A238	30 mm	0.75 mm
R3A248	30 mm	1.0 mm
R3A258	30 mm	1.25 mm
R3A268	30 mm	1.5 mm
R1A238	15 mm	0.75 mm
R1A248	15 mm	1.0 mm
R1A258	15 mm	1.25 mm

Standard Bell Applicator Models		
PART NO.	BELL CUP SIZE*	NOZZLE SIZE
R5A140	50 mm	1.0 mm
R5A150	50 mm	1.25 mm
R5A160	50 mm	1.5 mm
R3A130	30 mm	0.75 mm
R3A140	30 mm	1.0 mm
R3A150	30 mm	1.25 mm
R3A160	30 mm	1.5 mm
R1A130	15 mm	0.75 mm
R1A140	15 mm	1.0 mm
R1A150	15 mm	1.25 mm

Standard Bell Applicator Models		
PART NO.	BELL CUP SIZE*	NOZZLE SIZE
R5A148	50 mm	1.0 mm
R5A158	50 mm	1.25 mm
R5A168	50 mm	1.5 mm
R3A138	30 mm	0.75 mm
R3A148	30 mm	1.0 mm
R3A158	30 mm	1.25 mm
R3A168	30 mm	1.5 mm
R1A138	15 mm	0.75 mm
R1A148	15 mm	1.0 mm
R1A158	15 mm	1.25 mm

\*Bell cup is aluminum serrated on all applicator models

# Ordering Information

BELL CUPS						
PART NO.	SIZE	AIR CAP & COVER	MATERIAL	EDGE TYPE	FLOW RATE	PATTERN SIZE
24Z081	50 mm	25C287	Aluminum Standard	Smooth	50-500 cc per min	4-18 in (10-45 cm)
24Z084**	50 mm		Aluminum Standard	Serrated	50-500 cc per min	
24Z085	50 mm		Aluminum High Wear	Serrated	50-500 cc per min	
24Z083	50 mm		Composite	Smooth	50-500 cc per min	
24Z076	30 mm	25C286	Aluminum Standard	Smooth	25-400 cc per min	4-12 in (10-30 cm)
24Z079**	30 mm		Aluminum Standard	Serrated	25-400 cc per min	
24Z080	30 mm		Aluminum High Wear	Serrated	25-400 cc per min	
24Z078	30 mm		Composite	Smooth	25-400 cc per min	
24Z086	15 mm	25C285	Aluminum Standard	Smooth	25-100 cc per min	≤ 4 in (5-10 cm)
24Z088**	15 mm		Aluminum Standard	Serrated	25-100 cc per min	
24Z089	15 mm		Aluminum High Wear	Serrated	25-100 cc per min	
24Z087	15 mm		Composite	Smooth	25-100 cc per min	

\*\*Included with applicator

## 3 Choose Hose and Cable Length

COMPLETE HOSE BUNDLES***		
Solventbourne	Waterbourne	
24Z168	24Z711 ^	Hose bundle 11 m (35 ft)
24Z169	24Z712 ^	Hose bundle 20 m (65 ft)
24Z170	24Z713 ^	Hose bundle 30 m (100 ft)

\*\*\*Includes 9 air lines, 3 PTFE fluid lines, power supply cable, fiber optic cable and ground wire  
 ^Waterbourne does not include fluid lines, must be ordered separately

Waterborne Fluid Hose Kits (Shielded)		
Hollow Wrist	Standard Model	Description
24Z199	17L886	Hose, fluid, shielded, 11 m (35 ft)
24Z200	17L887	Hose, fluid, shielded, 20 m (65 ft)

Waterborne Fluid Hose Kits (Unshielded)		
Hollow Wrist	Standard Model	Description
24Z201	17L884	Hose, fluid, unshielded, 11 m (35 ft)
24Z202	17L885	Hose, fluid, unshielded, 20 m (65 ft)

INDIVIDUAL CABLES	
Electrostatic Power Cable from Electrostatic Controller to Applicator	
17J586	Power Cable 11 m (35 ft)
17J588	Power Cable 20 m (65 ft)
17J589	Power Cable 30 m (100 ft)

Fiber Optic Cable from Speed Controller to Applicator		
Hollow Wrist	Standard Model	Description
24Z193	24Z190	Fiber Optic Cable 11 m (35 ft)
24Z194	24Z191	Fiber Optic Cable 20 m (65 ft)
24Z195	24Z192	Fiber Optic Cable 30 m (100 ft)

ACCESSORIES	
24Z177	Gun Cover Standard Model (Qty 10)
24Z176	Gun Cover Hollow Wrist Robot Model (Qty 10)
24Z183	Reflective Speed Sensing Kit

NOZZLES	
25C206	0.75 mm
25C207	1.0 mm
25C208	1.25 mm
25C209	1.5 mm
26A524	1.8 mm
26A525	2.0 mm

WATERBOURNE FLUID HOSES		
Unshielded	Shielded	
17L884	17L886	Fluid Hose 11 m (35 ft)
17L885	17L887	Fluid Hose 20 m (65 ft)

## 4 Determine Installation Needs

MOUNTING BRACKETS	
24Z178	Reciprocator Rod Mounting Bracket
24Z179	60 Degree Solid Wrist Robot Mount Bracket

ROBOT ADAPTORS	
24Y128	Motoman EPX1250
24Y129	Motoman PX1450 and PX2850
24Y634	Motoman EPX2050
24Y650	Motoman EPX2700, 2800 and 2900

ROBOT ADAPTORS	
24Y768	Fanuc Paint Mate 200iA and 200iA/5L
24Y769	Fanuc P-50 and P-250
24Y172	ABB IRB 540
24Y173	ABB IRB 1400
24Y634	ABB IRB 580 and 5400

PROBELL GATEWAY INSTALLATION KIT ^^	
24Z574	Includes: CAN Cable, Cable Gland, Gateway Token

^^ Required for use with a Gateway Kit

GATEWAY KITS	
24W462	ModbusTCP
CGMDN0	DeviceNet®
CGMEP0	EtherNetIP®
CGMPN0	PROFINET®





ALUMINUM HIGH WEAR SERRATED



COMPOSITE SMOOTH



ALUMINUM SERRATED



ALUMINUM SMOOTH

# Technical Specifications

PROBELL ROTARY APPLICATOR		
	US	METRIC
Maximum air working pressure	100 psi	0.7 MPa, 7.0 bar
Maximum fluid working pressure	150 psi	1.0 MPa, 10.3 bar
Bearing air — minimum required	80 psi	0.55 MPa, 5.5 bar
Turbine speed — maximum operating	60,000 rpm	
Viscosity range	30-150 centistokes	
Maximum flow rate, 50 mm cup	500 cc/min	
Maximum flow rate, 30 mm cup	400 cc/min	
Maximum flow rate, 15 mm cup	100 cc/min	
Maximum voltage output	100 kV for solventborne systems 60 kV for waterborne systems	
Maximum current draw	150 micro-amperes	
Applicator weight	Hollow Wrist Model 13.5 lbs (6 kg) Standard Model 9 lbs (4 kg)	
Paint resistivity range	1 megohm/cm to infinity	

RELATED MANUALS	
MANUAL	DESCRIPTION
3A4232	ProBell Cart Systems
334452	ProBell Rotary Applicator
334626	ProBell Rotary Applicator, Hollow Wrist
3A3657	ProBell Electrostatic Controller
3A3953	ProBell Speed Controller
3A3954	ProBell Air Controller
3A3955	ProBell System Logic Controller



## ABOUT GRACO

### PROVEN QUALITY. LEADING TECHNOLOGY.

Founded in 1926, Graco is a world leader in fluid handling systems and components. Graco products move, measure, control, dispense and apply a wide range of fluids and viscous materials used in vehicle lubrication, commercial and industrial settings.

The company's success is based on its unwavering commitment to technical excellence, world-class manufacturing and unparalleled customer service. Working closely with qualified distributors, Graco offers systems, products and technology that set the quality standard in a wide range of fluid handling solutions. Graco provides equipment for spray finishing, protective coating, paint circulation, lubrication, and dispensing sealants and adhesives, along with power application equipment for the contractor industry. Graco's ongoing investment in fluid management and control will continue to provide innovative solutions to a diverse global market.

## GRACO LOCATIONS

### MAILING ADDRESS

P.O. Box 1441  
Minneapolis, MN 55440-1441  
Tel: 612-623-6000  
Fax: 612-623-6777

### AMERICAS

#### MINNESOTA

Worldwide Headquarters  
Graco Inc.  
88 -11th Avenue N.E.  
Minneapolis, MN 55413

### EUROPE

#### BELGIUM

European Headquarters  
Graco N.V.  
Industrieterrein-Oude Bunders  
Slakweidestraat 31  
3630 Maasmechelen,  
Belgium  
Tel: 32 89 770 700  
Fax: 32 89 770 777

### ASIA PACIFIC

#### AUSTRALIA

Graco Australia Pty Ltd.  
Suite 17, 2 Enterprise Drive  
Bundoora, Victoria 3083  
Australia  
Tel: 61 3 9467 8558  
Fax: 61 3 9467 8559

#### CHINA

Graco Fluid Equipment Co., Ltd.  
Shanghai Representative Office  
Building 7  
1029 Zhongshan Road South  
Huangpu District  
Shanghai 200011  
The People's Republic of China  
Tel: 86 21 649 50088  
Fax: 86 21 649 50077

#### INDIA

Graco India Pvt Ltd  
Plot No 295, Udyog Vihar Phase-IV  
Gurugram - 122015 (Haryana)  
India  
Tel: 91 124 661 0200  
Fax: 91 124 661 0201

#### JAPAN

Graco K.K.  
1-27-12 Hayabuchi  
Tsuzuki-ku  
Yokohama, Japan 224-0025  
Tel: 81 45 593 7300  
Fax: 81 45 593 7301

#### KOREA

Graco Korea Inc.  
38, Samsung 1-ro 1-gil  
Hwaseong-si, Gyeonggi-do,  
18449  
Republic of Korea  
Tel: 82 31 8015 0961  
Fax: 82 31 613 9801

## SALES/ DISTRIBUTION/ SERVICE

Call today for product information or to request a demonstration.

**877-84GRACO (1-877-844-7226)** or visit us at [www.graco.com](http://www.graco.com).

Graco Inc. is registered to I.S. EN ISO 9001

North America  
Customer Service  
800-328-0211  
Fax 877-340-6427